

WÜRTH

scule, accesorii, produse chimice
pentru producatorii de mobilier



mai mult decat iti imaginezi...



DYNAPRO si DYNAMOOV noua generatie de sisteme de glisare ascunse!

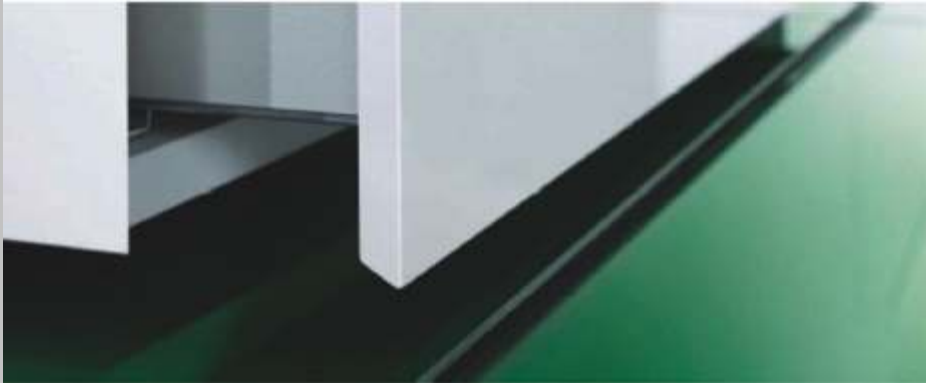

Trenduri actuale in designul mobilierului

- fronturi de sertare fara manere.
- fronturile sertarelor mai inalte si mai late.
- personalizarea in designul mobilierului, in general, si al sertarului, in special, duce la utilizarea glisierelor ascunse.



Toate acestea duc la urmatoarele cerinte ale glisierelor moderne:

- forta mica de extragere a sertarului.
- optiuni suplimentare de reglare a pozitiei frontului.
- solutii sofisticate de tip Tipmatic pentru aplicatii fara manere.
- excelente caracteristici de rulare si silentiozitate, chiar si in conditiile unei incarcari foarte mari.
- capacitati de incarcare mai mari datorate dimensiunilor mari ale sertarelor.

Caracteristicile noii generatii de glisiere ascunse

1 Rulare excelenta

Unicul sistem de glisare 100% sincronizat impresioneaza prin caracteristicile sale excelente de rulare si prin stabilitatea laterala mare.

Nicio interferenta sau zgomot create de componenta intermediara datorita realizarii primei sincronizari.



2 Sincronizare

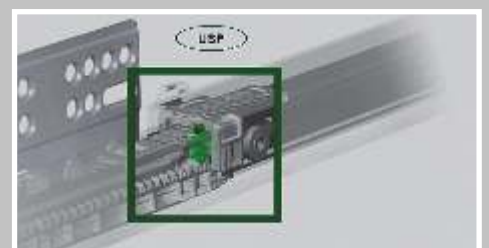

3 Forta de extragere mica



4 Capacitate de incarcare mare



5 Optiuni de reglare

reglare pe inaltime



reglare laterala



reglare inclinare front



DYNAPRO



- reglare pe inaltime +3,5 mm

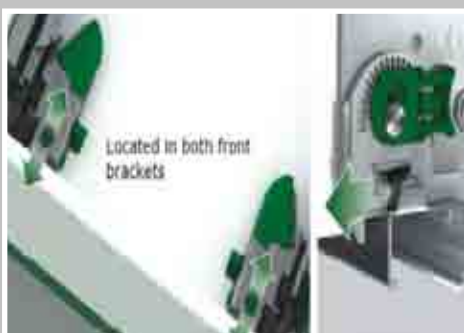

- reglare laterala \pm 1,5 mm



- reglare inclinare front + 4 mm

DYNAMOOV



- reglare pe inaltime +3,5 mm

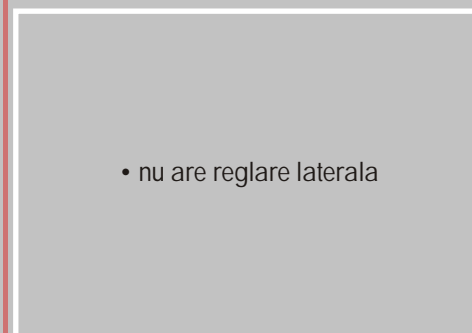

- nu are reglare laterala

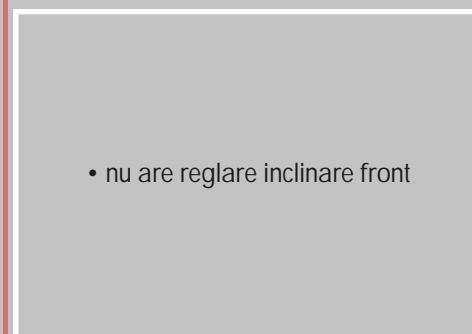

- nu are reglare inclinare front

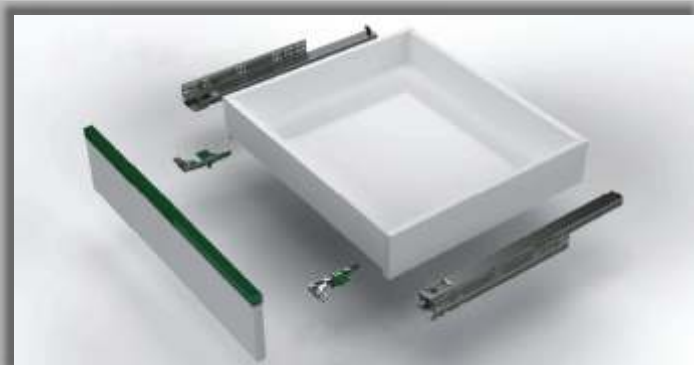
DYNAMOOV

NL [mm]	DYNAMOOV extragere totala soft-close 30 kg	DYNAMOOV extragere totala TIPMATIC 30 kg
250	-	-
270	B1130 101 101	B1130 101 114
300	B1130 101 102	B1130 101 115
350	B1130 101 104	B1130 101 117
400	B1130 101 106	B1130 101 119
450	B1130 101 108	B1130 101 121
500	B1130 101 110	B1130 101 123
550	B1130 101 112	B1130 101 125

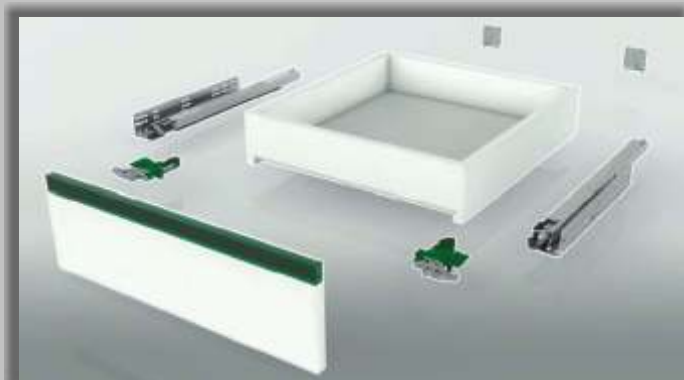
DYNAPRO

NL [mm]	DYNAPRO extragere totala soft-close 40 kg	DYNAPRO extragere totala soft-close 60 kg
250	B1130 116 014	-
270	B1130 116 015	-
300	B1130 116 016	-
350	B1130 116 018	-
400	B1130 116 020	-
450	B1130 116 022	B1130 116 027
500	B1130 116 024	B1130 116 028
550	B1130 116 026	B1130 116 030
580	-	B1130 116 031
600	-	B1130 116 032
650	-	B1130 116 033
700	-	B1130 116 034
750	-	B1130 116 035

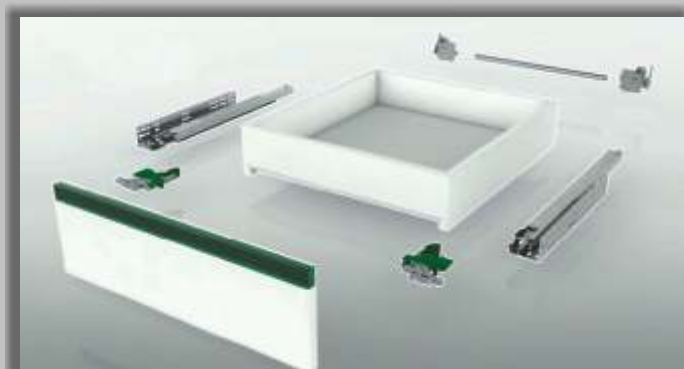
TIPMATIC PLUS
 – solutie pentru sertare fara maner

NL [mm]	DYNAPRO extragere totala TIPMATIC PLUS 40 kg	DYNAPRO extragere totala TIPMATIC PLUS 60 kg
250	B1130 116 036	-
270	B1130 116 037	-
300	B1130 116 038	-
350	B1130 116 040	-
400	B1130 116 042	-
450	B1130 116 044	B1130 116 049
500	B1130 116 046	B1130 116 050
550	B1130 116 048	B1130 116 052
580	-	B1130 116 053
600	-	B1130 116 054
650	-	B1130 116 055

Codul de articol B1* contine toate elementele necesare asamblarii unui sertar.

Dynamic NT

- extragere partiala
- cu amortizare integrata Soft-close
- incarcare dinamica pana la 30 kg
- rulare in combinatie pe bile si role de otel calit: glisare foarte silentioasa cu o stabilitate laterala superioara
- cuplare rapida si simpla: fixarea sertarului si demontarea se face simplu prin clipsare
- sistem de reglare pe verticala a sertarului cu + 2,5 mm fara scule
- sina de sertar ascunsa sub fundul sertarului: aspect estetic deosebit al mobilierului datorita lipsei elementelor vizibile.

NL Lungime nominala (mm)	Lungime de executie sertar (mm)	Art. Nr	U.A.
300	290	B1089 000 029	1/10
350	340	B1089 000 030	1/10
400	390	B1089 000 031	1/10
450	440	B1089 000 032	1/10
500	490	B1089 000 033	1/10
550	540	B1089 000 034	1/10

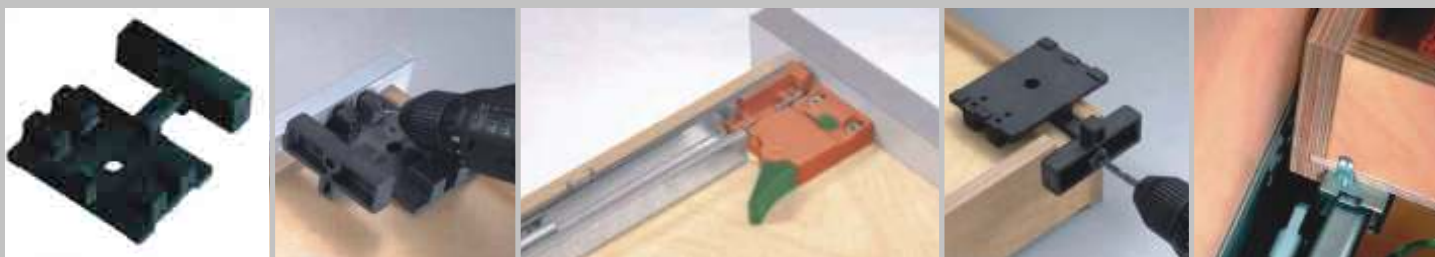

Codul de articol B1* contine toate elementele necesare asamblarii unui sertar.

Glisiera cu role

- extragere partiala
- incarcare 30 kg
- montaj sub sertar
- functie de autoinchidere cu panta discreta pe ultimii 60 mm
- opritor la capat de cursa – siguranta la extragerea la maxim a sertarului.



Lungime nominala (mm)	Culoare	Art. Nr.	Culoare	Art. Nr.	U.A.
250	alb RAL9010	F0080 073 982	maro RAL8014	F0080 073 983	1/25
300		F0080 073 985		F0080 073 986	
350		F0080 073 988		F0080 073 990	
400		F0080 073 992		F0080 073 993	
450		F0080 073 995		F0080 073 996	
500		F0080 073 998		F0080 073 999	
550		F0080 074 001		F0080 074 002	



* perechi

DWD XP sertare cu laterale metalice cu perete dublu

- produs de calitate superioara.
- recomandat depozitarii alimentelor.
- rezistent la zgarieturi.
- durata lunga de viata.
- protectie impotriva desprinderii involuntare a sertarului in timpul utilizarii sau transportului.
- ofera posibilitatea executiei fundului si spatelui sertarului la aceeasi latime (croire rationala a materialului).

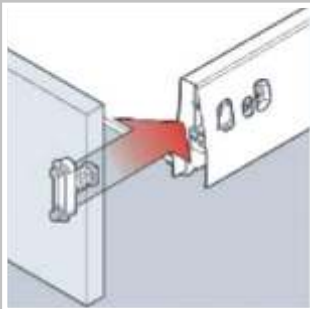

- fixare rapida si rezistenta a frontului de sertar prin intermediul unui conector din zamac

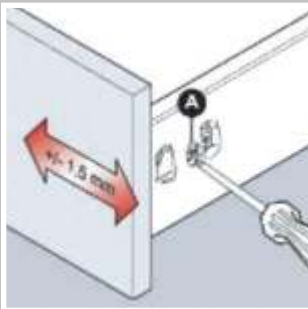

- sistem de reglare orizontala a frontului de sertar +/- 1,5 mm
- reglarea se face doar de pe o singura laterala a sertarului

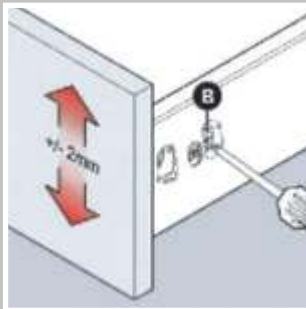

- sistem de reglare verticala a frontului de sertar +/- 2 mm



DWD XP H95 mm, 40 kg standard

Lungime	Art. Nr.	1 set contine :	Descriere
275 mm	B1090 075 275	1 per	Laterale metalice DWD XP gri
350 mm	B1090 075 350	2 buc	Capace de acoperire
400 mm	B1090 075 400	1 per	Suport spate stanga/dreapta H68 mm
450 mm	B1090 075 450	2 buc	Cuplaj front versiune cu suruburi
500 mm	B1090 075 500	1 per	Glisiera Dynamic XP extragere totala 40 kg cu Soft-close

Codul de articol B1* contine toate elementele necesare asamblarii unui sertar.

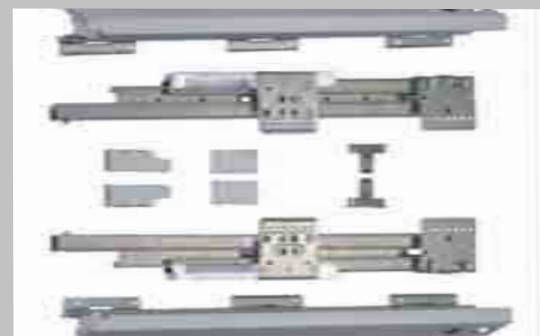
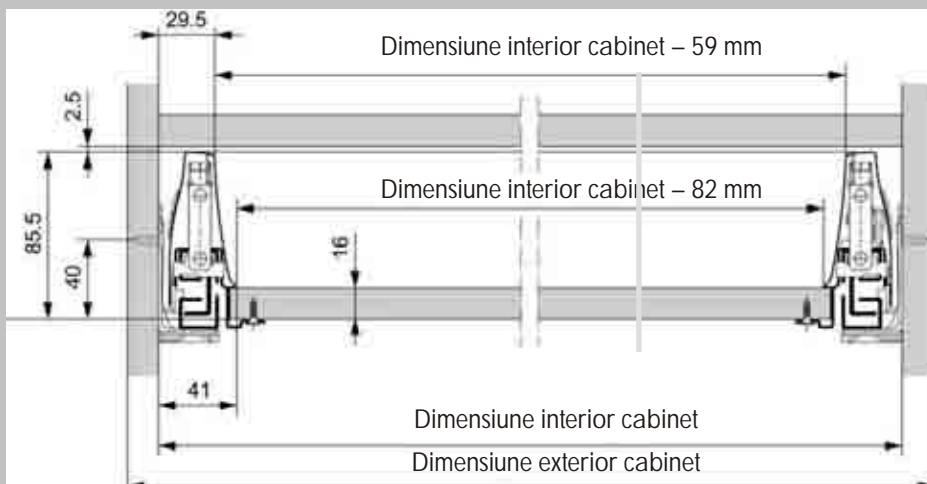

DWD XP H95 mm / 190 mm, 40 kg cu lonjeroane de suprainaltare

Lungime	Art. Nr	1 set contine:	Descriere
275 mm	B1091 075 275	1 per	Laterale metalice DWD XP gri
350 mm	B1091 075 350	2 buc	Capace de acoperire
400 mm	B1091 075 400	1 per	Suport spate stanga/dreapta H164 mm
450 mm	B1091 075 450	2 buc	Cuplaj front versiune cu suruburi
500 mm	B1091 075 500	1 per	Glisiera Dynamic XP extragere totala 40 kg cu Soft-close
		1 per	Lonjeroane de suprainaltare



Codul de articol B1* contine toate elementele necesare asamblarii unui sertar.

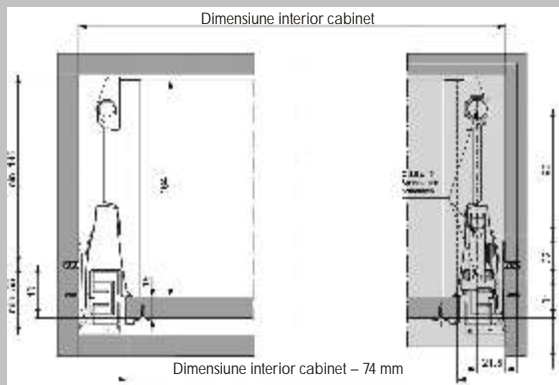

DWD interior de inaltime H95 mm

Lungime	Latime cabinet pana la:	
	600 mm	1200 mm
	Art. Nr.	Art. Nr.
275 mm	B1090 175 275	B1090 275 275
350 mm	B1090 175 350	B1090 275 350
400 mm	B1090 175 400	B1090 275 400
450 mm	B1090 175 450	B1090 275 450
500 mm	B1090 175 500	B1090 275 500

1 set contine :	Descriere
1 per	Laterale metalice DWD XP gri
2 buc	Capace de acoperire
1 per	Suport spate stanga/dreapta H68mm
1 per	Glisiera Dynamic XP extragere totala 40 kg cu Soft-close
1 buc	Front aluminiu pentru sertar interior DWD H95
1 per	Set collare de imbinare



Codul de articol B1* contine toate elementele necesare asamblarii unui sertar.

DWD XP interior H95 mm /190 mm cu lonjeroane de suprainaltare

Lungime	Latime cabinet pana la:	
	600	1200
	Art. Nr.	Art. Nr.
275 mm	B1091 175 275	B1091 275 275
350 mm	B1091 175 350	B1091 275 350
400 mm	B1091 175 400	B1091 275 400
450 mm	B1091 175 450	B1091 275 450
500 mm	B1091 175 500	B1091 275 500

Codul de articol B1* contine toate elementele necesare asamblarii unui sertar.



DWD XP cu front inalt si doua seturi de lonjeroane

Lungime	Art. Nr.	1 set contine:	Descriere
275 mm	B1092 075 275	1 per	Laterale metalice DWD XP gri
350 mm	B1092 075 350	2 buc	Capace de acoperire
400 mm	B1092 075 400	1 set	Suport spate 216-261 mm
450 mm	B1092 075 450	2 buc	Cuplaj front versiune cu suruburi
500 mm	B1092 075 500	1 per	Glisiera Dynamic XP extragere totala 40 kg cu Soft-close
		2 per	Lonjeroane de suprainaltare

Codul de articol B1* contine toate elementele necesare asamblarii unui sertar.



Separatoare pentru compartimentare

Descriere	Art. Nr.	U.A.
1. Tub pentru latime de cabinet pana la 600 mm (lungime 487 mm)	F0092 082 471	1
1. Tub pentru latime de cabinet pana la 1200 mm (lungime 1087 mm)	F0092 082 461	1
2. Adaptor simplu	F0092 082 484	1
3. Adaptor dublu	F0092 082 486	1
4. Separator de sticle si borcane	F0092 082 488	1



Duowing – Set de inaltatoare laterale din tabla de otel cu perete dublu pentru DWD XP

- inaltatoare cu forma inchisa, peretele interior perforat pentru lonjeroane si sisteme de organizare Magic Optima
- aspect placut
- montare si demontare usoara prin clipsarea pe lonjeroanele laterale

Lungime	Descriere	Art. Nr.	U.A.*
400 mm	Duowing – inaltatoare laterale	F0092 082 567	1/10
450 mm		F0092 082 570	
500 mm		F0092 082 572	
550 mm		F0092 082 576	

* U.A. perechi

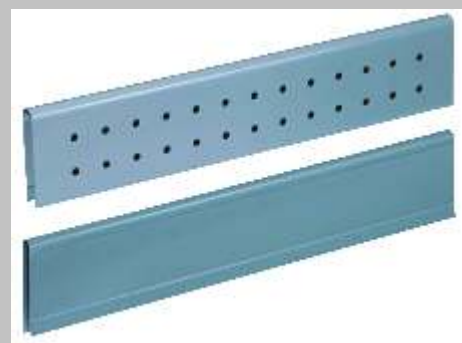

Solowing – Set de inaltatoare laterale din tabla de otel cu perete simplu pentru DWD XP

- inaltatoare perforate pentru lonjeroane si sisteme de organizare Magic Optima
- se pot monta si pe stanga si pe dreapta.
- aspect placut
- montare si demontare usoara prin clipsarea pe lonjeroanele laterale.

Lungime	Descriere	Art. Nr.	U.A.
400 mm	Solowing-inaltatoare laterale	F0092 075 750	1/20
450 mm		F0092 075 752	
500 mm		F0092 075 754	
550 mm		F0092 075 755	

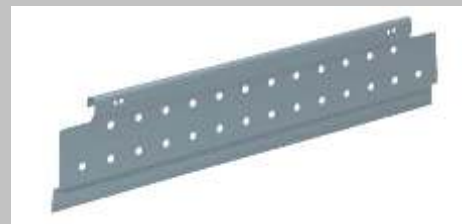

Variowing – Set cleme fixare laterale din sticla pentru sertar DWD XP

Art. Nr. F0092 082 588

- pentru sticla cu grosime de 4 mm
- se fixeaza prin clipsare.
- U.A. – 1 set



Magic Optima – sistem de organizare depozitare

- se utilizeaza in combinatie cu lonjeroanele laterale sau inaltatoarele Duowing si Solowing pe sertare DWD XP
- ofera posibilitatea de a individualiza si compartimenta sertarele in functie de necesitatile utilizatorilor
- montare fara a necesita scule
 - ofera posibilitatea schimbarii compartimentarii dupa instalarea mobilierului
 - pot fi montate de catre utilizator ulterior
- material: aluminiu RAL9006



Descriere	Art. Nr	U.A.
1. Profil pentru compartimentari sertar, latime cabinet pana la 600mm (lungime 472 mm)	F0092 075 813	1
1. Profil pentru compartimentari sertar, latime cabinet pana la 1200mm (lungime 1072 mm)	F0092 075 808	1
2. Clema prindere profil pentru lonjeroane laterale	F0092 075 823	2
3. Clema prindere profil pentru Duowing	F0092 075 819	2
4. Clema prindere profil pentru Solowing	F0092 075 821	2
5. Separator interior	F0092 075 826	1



Sertar sub chiuveta

Art. Nr. B1090 075

- acesta permite utilizarea eficienta a spatiului de sub chiuveta



1 set contine :	Descriere
1 per	Laterala sertar DWD H95 NL 500mm
1 per	Laterala sertar DWD H95 NL 275mm
4 buc	Capace de acoperire
2 per	Suport spate stanga/dreapta H164mm
4 buc	Cuplaj front versiune cu suruburi
1 per	Glisiera Dynamic XP ET 40 kg. Soft close NL 500mm
2 per	Lonjeroane de suprainaltare NL500mm

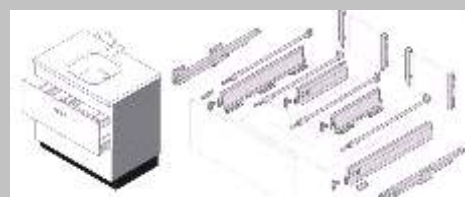

Containere pentru tacamuri Magic-Sorto

- seturi:
 - pentru cabinet de pana la 450 mm latime NL500mm.
 - pentru cabinet de pana la 600 mm latime NL500mm.
- material : containere din otel inoxidabil cu terminatii din material plastic.
- permite o compartimentare usoara si eficienta a interiorului sertarului.

Descriere	Art. Nr.	U.A.
Set pentru cabinet de pana la 450 mm latime	F0092 075 621	1
Set pentru cabinet de pana la 600 mm latime	F0092 075 631	1

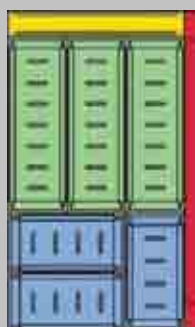

DWD Magic
organizare containere in
sertar de corp cu latime 450
mm:

- 3 Containere 270 x 90 mm
- 3 containerei 180 x 90 mm
- 1 perete capat 270 mm
- 1 traversa NL 500 mm



DWD Magic
organizare containere in
sertar de corp cu latime
600 mm:

- 4 Containere 270 x 90 mm
- 4 containerei 180 x 90 mm
- 2 perete capat 180 mm
- 1 traversa NL 500 mm

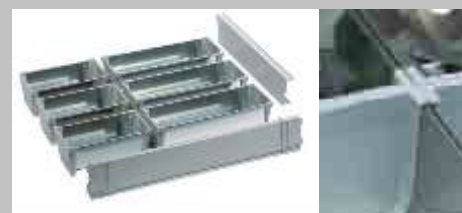

Sabloane si dispozitive

Marker pentru front
Art. Nr. F0146 083 256

Sablon pentru lonjeron
Art. Nr. F0146 083 261

Centruitor pentru suruburi de 3,5 mm
Art. Nr. 650 827

Sablon de corp cu rigla pentru gaurirea peretelui la fixarea glisierelor
Art. Nr. F0146 094 721



Balamale
Nexis Slide-on

- unghi de deschidere 100°
- cu mecanism de inchidere (arc)
- reglare tridimensionala
- cote de prelucrare.



pentru usa aplicata



Art. Nr. F0016 073 008
Fixare cu suruburi
U.A.: 1/250

Art. Nr. F0016 073 010
Fixare cu dibluri
U.A.: 1/250

pentru usa semiaplicata



Art. Nr. F0016 073 014
Fixare cu suruburi
U.A.: 1/250

Art. Nr. F0016 073 016
Fixare cu dibluri
U.A.: 1/250

pentru usa incadrata



Art. Nr. F0016 073 018
Fixare cu suruburi
U.A.: 1/250

Art. Nr. F0016 073 020
Fixare cu dibluri
U.A.: 1/250

Placute recomandate:

H0

Art.Nr. F0062 073 298
Montaj cu surub pt lemn
Art.Nr. F0062 073 316
Montaj cu surub Euro 13,5 mm

H2

Art.Nr. F0062 073 299
Montaj cu surub pt lemn
Art.Nr. F0062 073 317
Montaj cu surub Euro 13,5 mm

H4

Art.Nr. F0062 073 300
Montaj cu surub pt lemn
Art.Nr. F0062 073 318
Montaj cu surub Euro 13,5 mm

Nexis Click-on

- unghi de deschidere 110°
- cu mecanism de inchidere (arc)
- reglare tridimensionala
- cote de prelucrare.



pentru usa aplicata



Art. Nr. F0015 072 691
Fixare cu suruburi
U.A.: 1/50

pentru usa semiaplicata



Art. Nr. F0015 072 694
Fixare cu suruburi
U.A.: 1/50

pentru usa incadrata (100°)



Art. Nr. F0015 072 660
Fixare cu suruburi
U.A.: 1/50

Placute recomandate:

H0

Art.Nr. F0060 073 144
Montaj cu surub pt lemn

H2

Art.Nr. F0060 073 145
Montaj cu surub pt lemn

H4

Art.Nr. F0060 073 146
Montaj cu surub pt lemn

Nexis Slide-on deschidere 170°

Art. Nr. F0016 073 077
 Fixare cu suruburi
 U.A.: 1/50
 pentru usa aplicata

Placute recomandate:

H0
 Art.Nr. F0062 073 298
 Montaj cu surub pt lemn
 Art.Nr. F0062 073 316
 Montaj cu surub Euro 13,5 mm



- unghi de deschidere 170°
- ofera acces maxim la interiorul dulapului
- conceputa astfel incat nu prezinta riscul de a prinde degetele intre componentele ei la inchiderea/deschiderea usii
- potrivite a se utiliza pentru piesele de mobilier destinate copiilor
- toate modelele sunt echipate cu un sistem de autoinchidere cu arc.
- toate balamalele sunt compatibile Soft-close.
- permite o compartimentare usoara si eficienta a interiorului sertarului.

Nexis pentru usa franta la corp de colt

Art. Nr. F0016 073 100
 Fixare cu suruburi
 U.A.: 1/25
 pentru usa aplicata

Placute recomandate:

H0
 Art.Nr. F0062 073 299
 Montaj cu surub pt lemn
 Art.Nr. F0062 073 317
 Montaj cu surub Euro 13,5 mm



- unghi de deschidere 65°
- pentru usi cu grosimea de pana la 22 mm .
- toate modelele sunt echipate cu un sistem de autoinchidere cu arc.
- la usa franta se utilizeaza in combinatie cu balamaua de 170°

Nexis pentru usa la unghi +45°

Art. Nr. F0016 073 033
 Fixare cu suruburi
 U.A.: 1/25
 pentru usa aplicata

Placute recomandate:

H0
 Art.Nr. F0062 073 298
 Montaj cu surub pt lemn
 Art.Nr. F0062 073 316
 Montaj cu surub Euro 13,5 mm

H4
 Art.Nr. F0062 073 300
 Montaj cu surub pt lemn
 Art.Nr. F0062 073 318
 Montaj cu surub Euro 13,5 mm

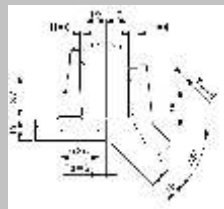
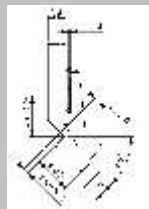

- la unghi +45°
- pentru utilizarea la cabinete cu usa la unghi de +45° fata de perete
- unghi de deschidere 94°
- pentru grosimi de usa de pana la 24 mm
- toate modelele sunt echipate cu un sistem de autoinchidere cu arc.

Nexis pentru usa si lezена

- unghi de deschidere 95°
- balama pentru lezена ingusta
- pentru grosimi de usa de pana la 24 mm
- include placuta de montaj
- model echipat cu un sistem de autoinchidere cu arc.

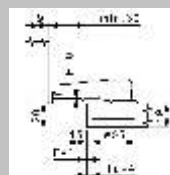

Art. Nr. F0016 072 994
Fixare cu suruburi
U.A.: 1/25

Nexis Mirro

- unghi de deschidere 128°
- balama pentru usa din sticla, oglinda
- pentru grosimi de usa de la 3 la 8 mm
- include placuta de montaj
- model echipat cu un sistem de autoinchidere cu arc.
- se lipeste cu adeziv metal-sicla



Art. Nr. F0015 072 865
U.A.: 1 set*

* un set contine: 2 balamale, 2 placute de fixare



Amortizoare

Amortizor AirMatic

- amortizor pe aer - fiabilitate si eficienta ridicata,
- pentru reducerea zgomotului la inchiderea usii
- se monteaza fie intr-o gaura Ø10 x 60 mm, fie prin intermediul unui adaptor

Art. Nr. F0069 066 528
U.A.: 1/25



Amortizor Mirro

- pentru reducerea zgomotului la inchiderea usii
- se monteaza prin clipsare pe balamaua Mirro
- surub ce permite reglarea fortei de amortizare a inchiderii usii

Art. Nr. F0069 073 711
U.A.: 1



Amortizor Soft-close – pentru balamale Nexis 100°, 110°

- pentru inchiderea silentioasa a usii
- montaj simplu si rapid fara utilizarea de scule sau prelucrari suplimentare
- inalta performanta functionala
- surub ce permite reglarea fortei de amortizare a inchiderii usii
- potrivit pentru balamale de usa aplicata, semiaplicata, incadrata sau la unghi, exemplu: +30°, +45° etc

Art. Nr. F0069 073 715
U.A.: 1/25



Amortizor Soft-close – pentru balamale Nexis 170°

- pentru inchiderea silentioasa a usii.
- montaj simplu si rapid fara utilizarea de scule sau prelucrari suplimentare.
- inalta performanta functionala.
- surub ce permite reglarea fortei de amortizare a inchiderii usii.
- potrivit pentru balamale de usa aplicata, semiaplicata, incadrata

Art. Nr. F0069 073 730
U.A.: 1



Sistem Tipmatic deschiderea usilor fara maner

- mecanismul Tipmatic impreuna cu balamalele Nexis fara arc va permite sa deschideti usi fara maner.
- deschiderea usii se face apasand in fata si elibarand usa brusc.
- inchiderea usii se face apasand usor usa pana cand atinge magnetul 2.

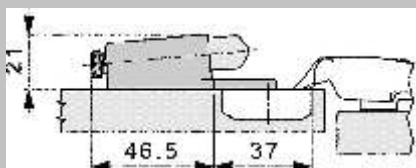

Descriere	Mecanism Tipmatic pentru balama Nexis (1)	Opritor magnetic pentru mecanism Tipmatic (2)
Art. Nr.	F069 073 754	F069 135 021
U.A.	1	1

Nexis Click-on 110° fara arc
pentru usa aplicata
Art. Nr. F0015 072 692
Fixare cu suruburi
U.A.: 1/50

Nexis Click-on 110° fara arc
pentru usa semiaplicata
Art. Nr. F0015 072 695
Fixare cu suruburi
U.A.: 1/50

Nexis Click-on 100° fara arc
pentru usa incadrata
Art. Nr. F0015 072 661
Fixare cu suruburi
U.A.: 1/50

Placute recomandate:

H0
Art.Nr. F0060 073 144
Montaj cu surub pt lemn

H2
Art.Nr. F0060 073 145
Montaj cu surub pt lemn

H4
Art.Nr. F0060 073 146
Montaj cu surub pt lemn

Gama suruburi pentru lemn WÜPOFAST

WÜPOFAST



Ø mm	x mm	L mm	x mm	b mm	Culoare bit				UA buc.			
					Art.-Nr.	Art.-Nr.	Art.-Nr.	Art.-Nr.				
2,4		12			198 24 12		186 24 12		1000			
		16			198 24 16		186 24 16					
		10			198 3 10		186 3 10					
		12			198 3 12		186 3 12					
		13			198 3 13		186 3 13					
		15			198 3 15		186 3 15					
		16			198 3 16		186 3 16					
		17			198 3 17		186 3 17					
		20			198 3 20		186 3 20					
		25			198 3 25		186 3 25					
		30			198 3 30		186 3 30					
		35			198 3 35		186 3 35					
3,0		40			198 3 40		186 3 40		500			
		45			198 3 45		186 3 45					
		12			198 35 12		186 35 12					
		13			198 35 13		186 35 13					
		15			198 35 15		186 35 15					
		16			198 35 16		186 35 16					
		17			198 35 17		186 35 17					
		20			198 35 20		186 35 20					
		22			198 35 22		186 35 22					
		25			198 35 25		186 35 25					
		17			198 35 25	198 135 25	186 135 25	186 135 25				
		3,5		30			198 35 30			186 35 30		1000
17					198 35 30	198 135 30	186 135 30	186 135 30				
35					198 35 35		186 35 35					
22					198 35 35	198 135 35	186 135 35	186 135 35				
40					198 35 40		186 35 40					
24					198 35 40	198 135 40	186 135 40	186 135 40				
45					198 35 45		186 35 45					
30					198 35 45	198 135 45	186 135 45	186 135 45				
50					198 35 50		186 35 50					
30					198 35 50	198 135 50	186 135 50	186 135 50				
4,0				12			198 4 12		186 4 12		1000	
				13			198 4 13		186 4 13			
		15			198 4 15		186 4 15					
		16			198 4 16		186 4 16					
		17			198 4 17		186 4 17					
		20			198 4 20		186 4 20					
		22			198 4 22		186 4 22					
		25			198 4 25		186 4 25					
		16			198 4 25	198 14 25	186 14 25	186 14 25				
		27			198 4 27		186 4 27					
		30			198 4 30		186 4 30					
		18			198 4 30	198 14 30	186 14 30	186 14 30				
4,0		35			198 4 35		186 4 35		500			
		21			198 4 35	198 14 35	186 14 35	186 14 35				
		40			198 4 40		186 4 40					
		24			198 4 40	198 14 40	186 14 40	186 14 40				
		45			198 4 45		186 4 45					
		29			198 4 45	198 14 45	186 14 45	186 14 45				
		50			198 4 50		186 4 50					
		30			198 4 50	198 14 50	186 14 50	186 14 50				
		55			198 4 55		186 4 55					
		34			198 4 55	198 14 55	186 14 55	186 14 55				
		60			198 4 60		186 4 60					
		34			198 4 60	198 14 60	186 14 60	186 14 60				
4,5		70			198 4 70		186 4 70		250			
		13			198 4 70	198 14 70	186 14 70	186 14 70				
		15			198 45 15		186 45 15					
		16			198 45 16		186 45 16					
		17			198 45 17		186 45 17					
		20			198 45 20		186 45 20					
		25			198 45 25		186 45 25					
		30			198 45 30		186 45 30					
		35			198 45 35		186 45 35					
		21			198 45 35	198 145 35	186 145 35	186 145 35				
		40			198 45 40		186 45 40					
		24			198 45 40	198 145 40	186 145 40	186 145 40				
45			198 45 45		186 45 45							
28			198 45 45	198 145 45	186 145 45	186 145 45						

Ø mm	x mm	L mm	x mm	b mm	Culoare bit				UA buc.	
					Art.-Nr.	Art.-Nr.	Art.-Nr.	Art.-Nr.		
4,5		50		30	198 45 50		186 45 50		250	
		55			198 45 55		186 45 55			
		60		35	198 45 60		186 45 60			
		65		38		198 145 60		186 145 60		
		70				198 145 65		186 145 65		
		70		40			198 145 70			186 145 70
		80		50			198 145 80			186 145 80
		16				198 5 16		186 5 16		
		17				198 5 17		186 5 17		
		20				198 5 20		186 5 20		
		25				198 5 25		186 5 25		
		30				198 5 30		186 5 30		
5,0		30		20		198 15 30		186 15 30	500	
		35			198 5 35		186 5 35			
		24			198 5 35	198 15 35	186 15 35	186 15 35		
		40			198 5 40		186 5 40			
		24			198 5 40	198 15 40	186 15 40	186 15 40		
		45			198 5 45		186 5 45			
		30			198 5 45	198 15 45	186 15 45	186 15 45		
		50			198 5 50		186 5 50			
		30			198 5 50	198 15 50	186 15 50	186 15 50		
		55			198 5 55		186 5 55			
		35			198 5 55	198 15 55	186 15 55	186 15 55		
		5,0		60		35	198 5 60			186 5 60
65					198 5 60		186 5 60			
70					198 5 60	198 15 60	186 15 60	186 15 60		
65					198 5 65		186 5 65			
70					198 5 70		186 5 70			
40					198 5 70	198 15 70	186 15 70	186 15 70		
80					198 5 80		186 5 80			
50					198 5 80	198 15 80	186 15 80	186 15 80		
90					198 5 90		186 5 90			
100					198 5 100		186 5 100			
110					198 5 110		186 5 110			
120					198 5 120		186 5 120			
6,0		40		24	198 6 40		186 6 40		200	
		45		30	198 6 45		186 6 45			
		50			198 6 50		186 6 50			
		30			198 6 50	198 15 50	186 15 50	186 15 50		
		55			198 6 55		186 6 55			
		35			198 6 55	198 15 55	186 15 55	186 15 55		
		60			198 6 60		186 6 60			
		35			198 6 60	198 15 60	186 15 60	186 15 60		
		70			198 6 70		186 6 70			
		42			198 6 70	198 15 70	186 15 70	186 15 70		
		80			198 6 80		186 6 80			
		50			198 6 80	198 15 80	186 15 80	186 15 80		
90			198 6 90		186 6 90					
56			198 6 90	198 15 90	186 15 90	186 15 90				
100			198 6 100		186 6 100					
110			198 6 110		186 6 110					
120			198 6 120		186 6 120					
140			198 6 140		186 6 140					
150			198 6 150		186 6 150					
160			198 6 160		186 6 160					
180			198 6 180		186 6 180					
200			198 6 200		186 6 200					
220			198 6 220		186 6 220					
240			198 6 240		186 6 240					

- asezare precisa, fara centruire pe suprafete dure cum ar fi: placi melaminate sau furniruite, precum si pe orice tip de lemn
- insurubare usoara datorita spirelor ascutite si flancurilor netede

Gama suruburi pentru lemn ASSY 3.0

- datorita geometriei speciale a filetului se obtin valori ridicate ale vitezei si sigurantei la montaj
- antrenarea AW asigura transmiterea mai buna a fortei
- varf perforant datorita formei speciale
- freze pe tija si sub cap pentru inaintare usoara si zencuire (la suruburi mai mari de Ø5 x 70 mm)



ASSY

3.0						4.0						3.5						4.5								
mm	L mm	b mm	An-trieb	Art.-Nr.	Art.-Nr.	Art.-Nr.	Art.-Nr.	U.A.	mm	L mm	b mm	An-trieb	Art.-Nr.	Art.-Nr.	Art.-Nr.	Art.-Nr.	VE/St.	mm	L mm	b mm	An-trieb	Art.-Nr.	Art.-Nr.	Art.-Nr.	Art.-Nr.	VE/St.
3.0	10		AW ¹⁰	0170 030 10		0170 230 10		1000	4.0	12		AW ²⁰	0170 040 12		0170 240 12		1000	4.0	12		AW ²⁰	0170 040 12		0170 240 12		1000
	12			0170 030 12		0170 230 12				13			0170 040 13		0170 240 13											
	13			0170 030 13		0170 230 13				15			0170 040 15		0170 240 15											
	15			0170 030 15		0170 230 15				16			0170 040 16		0170 240 16											
	16			0170 030 16		0170 230 16				17			0170 040 17		0170 240 17											
	17			0170 030 17		0170 230 17				20			0170 040 20		0170 240 20											
	20			0170 030 20		0170 230 20				12				0170 140 20		0170 340 20										
	12				0170 130 20		0170 330 20				25			0170 040 25		0170 240 25										
	25			0170 030 25		0170 230 25				18			0170 140 25		0170 340 25											
	17				0170 130 25		0170 330 25				30			0170 040 30		0170 240 30										
	30			0170 030 30		0170 230 30				18			0170 140 30		0170 340 30											
	17				0170 130 30		0170 330 30				35			0170 040 35		0170 240 35										
35		0170 030 35		0170 230 35		21		0170 140 35		0170 340 35																
22			0170 130 35		0170 330 35		40		0170 040 40		0170 240 40															
40		0170 030 40		0170 230 40		24		0170 140 40		0170 340 40																
25			0170 130 40		0170 330 40		45		0170 040 45		0170 240 45															
45		0170 030 45		0170 230 45		29		0170 140 45		0170 340 45																
16			0170 435 16				50		0170 040 50		0170 240 50															
20			0170 435 20				29		0170 140 50		0170 340 50															
25			0170 435 25				55		0170 040 55		0170 240 55															
30			0170 435 30				34		0170 140 55		0170 340 55															
35			0170 435 35				60																			
12			0170 035 12		0170 235 12		34		0170 140 60		0170 340 60															
13			0170 035 13				34		0170 140 70		0170 340 70															
15			0170 035 15		0170 235 15		13																			
16			0170 035 16		0170 235 16		15		0170 045 15																	
17			0170 035 17		0170 235 17		17		0170 045 17		0170 245 17															
20			0170 035 20		0170 235 20		20		0170 045 20		0170 245 20															
12			0170 035 25		0170 235 25		25		0170 045 25		0170 245 25															
25			0170 035 25		0170 235 25		30		0170 045 30		0170 245 30															
17			0170 035 30		0170 235 30		35		0170 045 35		0170 245 35															
30			0170 035 30		0170 235 30		21		0170 045 40	0170 145 35	0170 245 40	0170 345 35														
35			0170 035 35		0170 235 35		40		0170 045 40	0170 145 40	0170 245 40	0170 345 40														
21			0170 035 35		0170 235 35		45		0170 045 45	0170 145 45	0170 245 45	0170 345 45														
40			0170 035 40		0170 235 40		26		0170 045 50	0170 145 50	0170 245 50	0170 345 50														
25			0170 035 45		0170 235 45		50		0170 045 50	0170 145 50	0170 245 50	0170 345 50														
45			0170 035 45		0170 235 45		28		0170 045 55	0170 145 55	0170 245 55	0170 345 55														
30			0170 035 50		0170 235 50		55		0170 045 55	0170 145 55	0170 245 55	0170 345 55														
50			0170 035 50		0170 235 50		60		0170 045 60	0170 145 60	0170 245 60	0170 345 60														
30			0170 035 50		0170 235 50		33			0170 145 60		0170 345 60														
			0170 135 50		0170 335 50		70																			
			0170 135 50		0170 335 50		38			0170 145 70		0170 345 70														
			0170 135 50		0170 335 50		80		0170 145 80		0170 345 80															

ASSY



mm	L mm	b mm	Antrieb	d _k mm	Senkkopf verzinkt				d _k mm	VE/St.	
					Art.-Nr.	Art.-Nr.	Art.-Nr.	Art.-Nr.			
5,0	16		AW* 20	9,5	0170 050 16				9,5	500	
	17										
	20				0170 050 20		0170 250 20				
	25				0170 050 25		0170 250 25				
	30				0170 050 30		0170 250 30				
	35	20			0170 050 35	0170 150 30		0170 350 30			
	35	20			0170 050 35	0170 150 35		0170 350 35			
	40				0170 050 40		0170 250 40				
	40				0170 050 40	0170 150 40		0170 350 40			
	45				0170 050 45		0170 250 45				
	45	30			0170 050 45	0170 150 45		0170 350 45			
	50	30			0170 050 50	0170 150 50		0170 350 50			
	55	32			0170 050 55	0170 150 55		0170 350 55			
	60	37			0170 050 60	0170 150 60		0170 350 60			
	70	42			0170 050 70	0170 150 70		0170 350 70			
	80	42			0170 050 80	0170 150 80		0170 350 80			
	90	47			0170 050 90	0170 150 90		0170 350 90			
	100	52			0170 050 100	0170 150 100		0170 350 100			
	110	52			0170 050 110	0170 150 110		0170 350 110			
	120	62			0170 050 120	0170 150 120		0170 350 120			
6,0	30		AW* 30	12,0	0170 060 30				12,0	250	
	40				0170 060 40		0170 260 40				
	45	24			0170 060 45	0170 160 40		0170 360 40			
	50				0170 060 50		0170 260 50				
	55	32			0170 060 55	0170 160 50		0170 360 50			
	60				0170 060 60		0170 260 60				
	60				0170 060 60	0170 160 60		0170 360 60			
	70	37			0170 060 70	0170 160 70		0170 360 70			
	70	42			0170 060 70	0170 160 70		0170 360 70			
	80				0170 060 80		0170 260 80				
	80				0170 060 80	0170 160 80		0170 360 80			
	90	50			0170 060 90	0170 160 90		0170 360 90			
	100	60			0170 060 100	0170 160 100		0170 360 100			
	110	70			0170 060 110	0170 160 110		0170 360 110			
	120	70			0170 060 120	0170 160 120		0170 360 120			
	130	70			0170 060 130	0170 160 130		0170 360 130			
	140	70			0170 060 140	0170 160 140		0170 360 140			
	150	70			0170 060 150	0170 160 150		0170 360 150			
	160	70			0170 060 160	0170 160 160		0170 360 160			
	180	70			0170 060 180	0170 160 180		0170 360 180			
200	70	0170 060 200	0170 160 200		0170 360 200						
220	70	0170 060 220	0170 160 220		0170 360 220						
240	70	0170 060 240	0170 160 240		0170 360 240						
260	70	0170 060 260	0170 160 260		0170 360 260						
280	70	0170 060 280	0170 160 280		0170 360 280						
300	70	0170 060 300	0170 160 300		0170 360 300						

mm	L mm	b mm	Antrieb	d _k mm	Senkkopf verzinkt		VE/St.				
					Art.-Nr.	Art.-Nr.					
7,0	80	50	AW* 30	13,85	0170 370 80		100				
	90	50			0170 370 90						
	100	60			0170 370 100						
	120	70			0170 370 120						
	140	70			0170 370 140						
	160	85			0170 370 160						
	180	85			0170 370 180						
	200	85			0170 370 200						
	220	85			0170 370 220						
	240	85			0170 370 240						
	260	85			0170 370 260						
	280	85			0170 370 280						
	300	85			0170 370 300						
	80	50			0170 380 80						
	100	60			0170 380 100						
	120	80			0170 380 120						
	140	80			0170 380 140						
	160	80			0170 380 160						
	180	80			0170 380 180						
	200	80			0170 380 200						
220	100	0170 380 220									
8,0	240	100	AW* 40	15,1	0170 380 240		75				
	260	100			0170 380 260						
	280	100			0170 380 280						
	300	100			0170 380 300						
	320	100			0170 380 320						
	340	100			0170 380 340						
	360	100			0170 380 360						
	380	100			0170 380 380						
	400	100			0170 380 400						
	80	50			0170 310 80						
	100	60			0170 310 100						
	120	80			0170 310 120						
	140	80			0170 310 140						
	160	100			0170 310 160						
	180	100			0170 310 180						
	200	100			0170 310 200						
	220	100			0170 310 220						
	10,0	240			100	AW* 40		18,6	0170 310 240		50
		260			100				0170 310 260		
		280			100				0170 310 280		
300		100	0170 310 300								
320		120	0170 310 320								
340		120	0170 310 340								
360		120	0170 310 360								
380		120	0170 310 380								
400		120	0170 310 400								

Sisteme de fixare



Demontabili SV20 din zamac nichelat cu excentric precomtat

Art.Nr. F0069 073 444 1
Art.Nr. F0069 073 447 2



Excentric Ø15x13,5 mm
Art.Nr. 683 218 105



Eurosurub antrenare SW4
7 x 50 mm Art.Nr. 276 27 50
7 x 70 mm Art.Nr. 276 27 70



Eurosurub antrenare PZ2
6 x 13 mm
Art.Nr. 276 060 13



Tirant pentru demontabil SV20
Art.Nr. 683 226 001



Tirant cu filet euro
Art.Nr. 0683 211 03



Tirant cu filet M6
Art.Nr. 683 210 010



Bucsa expandabila din alama
M6 x 9 mm Art.Nr. 683 263 003
M6 x 12 mm Art.Nr. 683 263 004



Surub pentru manere
M4 x 10 mm Art.Nr. 275 350 10
M4 x 22 mm Art.Nr. 275 350 22
M4 x 25 mm Art.Nr. 275 350 25
M4 x 30 mm Art.Nr. 275 350 30
M4 x 40 mm Art.Nr. 275 350 40



Cepuri din lemn de fag
Ø 8 x 25 Art.nr. 907 008 25
Ø 8 x 30 Art.nr. 907 008 30
Ø 8 x 35 Art.nr. 907 008 35
Ø 8 x 40 Art.nr. 907 008 40



Lamele de imbinare din lemn
Tip 0 Art.nr. 907 250 0
Tip 10 Art.nr. 907 250 10
Tip 20 Art.nr. 907 250 20



Capse tapiterie Tip 80
L 8 mm Art.nr. 480 129 08
L 10 mm Art.nr. 480 129 10
L 12 mm Art.nr. 480 129 12
L 14 mm Art.nr. 480 129 14
L 16 mm Art.nr. 480 129 16



Cuie Tip WX
L 19 mm Art.nr. 480 12 16
L 25 mm Art.nr. 480 12 25
L 30 mm Art.nr. 480 12 30
L 35 mm Art.nr. 480 12 35
L 38 mm Art.nr. 480 12 38



Suport pentru polita
Ø5x15 mm
Art.Nr. 683 315



Suport pentru polita
transparent Art.Nr. 683 299
alb Art.Nr. 683 300



Picior pt mobilier Tip B
Reglare -10 mm la +20 mm
H100mm Art.Nr. 683 360 301
H125mm Art.Nr. 683 360 302



Manere
Art.Nr. 685 310 024
Art.Nr. 685 310 098
Art.Nr. 685 310 110



Picior pt mobilier Tip F
Reglare +20 mm
Art.Nr. 683 360 440



Picior pt mobilier Tip G
Reglare +20 mm
Art.Nr. 683 360 445



Clema fixare plinta
Art.Nr. 683 360 021



Suport metallic Tip A pentru polita
Ø12/7x120 mm Art. Nr. 683 350
Ø12/7x160 mm Art. Nr. 683 351
Diblu Art. Nr. 906 208 46



Suport universal reglabil pentru corpuri suspendate

alb Art. Nr. F0155 000 000
 nichelat Art. Nr. F0155 000 001



**Suport metalic Tip D / E pentru polita
 Reglare 3D**

Ø12x112 mm Art. Nr. 683 355
 Ø12x112 mm Art. Nr. 683 356



Diblu pentru gips-carton W-GS

Tip Z (zinc turnat sub presiune) Art. Nr. 903 252
 Tip K (material plastic ABS) Art. Nr. 903 251



Bara fixare corpuri suspendate
 Art. Nr. 683 712 3



Diblu Zebra-Shark

Fara guler (rosu) Art. Nr. 906 008 51
 Cu guler (alb) Art. Nr. 906 008 52



Diblu gri din nylon

6 x 30 mm Art. Nr. 903 96 30
 8 x 40 mm Art. Nr. 903 98 40
 10 x 50 mm Art. Nr. 903 910 50

! Sisteme de usi culisante

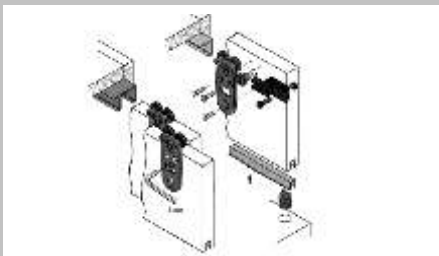

Sistem pentru usi glisante RSB 20

- incarcare 40 kg
- grosimea usii 20 - 25 mm
- reglare verticala a usii +/- 3 mm



Sistem pentru usi glisante SB 20 E

- incarcare 20 kg
- reglare verticala a usii +/- 3 mm

Descriere	Art. Nr.	Cant. pentru 2 usi	Cant. pentru 3 usi
Carucior de rulare superior	684 700 606	2	2
Carucior de rulare superior	684 700 616	2	4
Opritor	684 700 625	4	6
Pin ghidare inferior	684 700 628	2	3
Profil rulare superior 3,5 m	684 700 633	1	1
Profil ghidare inferior 3,5 m	684 700 014	1	1

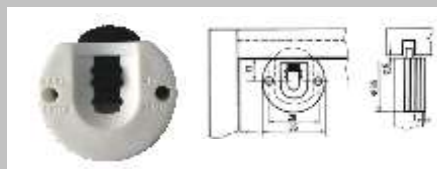

Rola inferioara alba Art. Nr. 684 562 102
 Rola inferioara maro Art. Nr. 684 562 103

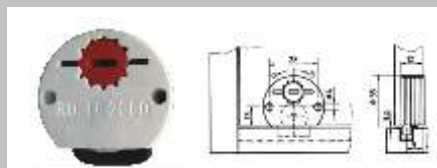

Rola inferioara alba Art. Nr. 684 562 100
 Rola inferioara maro Art. Nr. 684 562 101

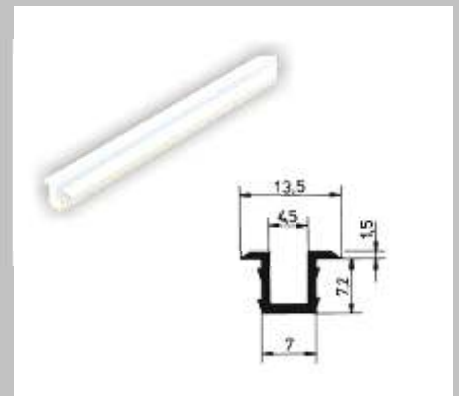

Profil de rulare PVC 3 m alb Art. Nr. 684 562 104
 Profil de rulare PVC 3 m maro Art. Nr. 684 562 105
 Profil de rulare PVC 3 m negru Art. Nr. 684 562 106
 Profil de rulare PVC 3 m gri Art. Nr. 684 562 107

! Scule de mana

Dispozitive de prindere universale cu manson inox, inel retinere si magnet permanent

Prindere		Antrenare	Lungime mm	Utilizare	Art. Nr.	UA.
1/4" E 6.3		1/4"	74	Würth, Bosch, Skil, Atlas Copco, Ingersoll, Hitachi, Makita, AEG, Metabo, Black & Decker, Deprag	614 176 702	1
1/4" C 6.3		1/4"	51	Würth, Bosch, Skil, Atlas Copco, Ingersoll, Hitachi, Makita, AEG, Metabo, Black & Decker, Deprag	614 176 697	

Biti cu cap cruce PH si PZ

Tip cruce	PH	PZ	PH	PZ	PH	PZ	PH	PZ
Marime	1	2	3	4				
Suruburi auto perforante	Ø Filet 2.4/3	3.5/4/4.5/5	6/7	8...				

Biti AW

Tip cruce	AW	AW	AW	AW
Marime	10	20	30	40
Suruburi auto perforante	Ø Filet 3	3.5/4/4.5/5	6/7	8/10

Biti cu cap hexagonal

Tip cruce	SW 2	SW 2.5	SW 3	SW 4	SW 5	SW 6
Marime	2	2.5	3	4	5	6

Trusa biti tamplarie

Art.Nr. 614 250 101

Tipuri biti:
PH, PZ, TX, SW,

Surubelnita cu magazie de 12 biti

Maner bicomponent 2K.
Tija rotunda cromată cu magnet
DIN3126-D6.3

- magazie de biti cu dimensiune extrem de redusa pentru o manuire optima
- magazie extensibila, rotativa, permite alegerea usoara a bitului.
- prindere bit-standard 1/4"
- contine biti Würth cu inel colorat pentru identificare rapida
- magazia de biti se blocheaza in maner

Ø	A	B1/B2	C	Art.-Nr.	UA.
1/4"	90	121/181	375	613 600 1*	1

* fara biti

Surubelnita Pozidriv

Tija: Rotunda, cromata
Varf: ISO 8764-PZ, Black Point.
Standard: DIN 5262.

Tip cruce	mm	mm	Art.-Nr.
PZ1	80	96/31	613 233 1
PZ2	100	106/35	613 233 2
PZ3	150	114/38	613 233 3
PZ4	200	120/41	613 233 4

Chinga simpla

L m	B mm	F1* daN	Art. -Nr.	UA.
2	25	500	713 92 20	1
4	25	500	713 92 10	
8	50	1000	713 92 11	

Rulete de buzunar

- banda etalonata de inalta calitate, foarte stabila datorita formei curbate.
- carcasa din plastic foarte usoara si rezistenta la coroziune



- la rulare, capatul benzii este prevazut cu un amortizor de socuri, ceea ce conduce la utilizare indelungata.
- carlig autoreglabil

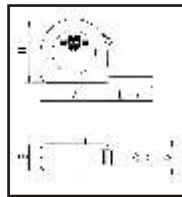

A mm	B mm	H max mm	L b m	mm	Art.-Nr.	 1
53	21	49	2	13	714 64 510	
63	25	59	3	16	714 64 511	
70	29	66	5	19	714 64 512	
77	34	73	7	25	714 64 513	

Nivela laser linie CLL 06



- consum mic de energie
- rezistenta la socuri
- previne erorile de nivelare
- utilizare simpla
- acuratete ± 2 mm la 10 m
- lungimea liniilor de 25 m la 10 m distanta de perete
- temperatura de lucru: 0- 40° C

Art. Nr. 714 640 130

Nivela laser linie CLL 06

Art. Nr. 714 640 760

- dispozitiv de masurat lungimi si de calculat dimensiuni de camere
- extrem de usor
- operatii usoare si rapide
- precizie foarte buna



Subler digital 0 ÷ 150 mm

Art.-Nr. 715 76 19



- domeniu de masurare: 0 ÷ 150 mm / 0 ÷ 6 inch.
- scala masurare: 0,01 mm / 0,0005 inch.
- precizie masurare: 0,03 mm / 0,001 inch;
- viteza maxima de reglaj: 1,5 m/sec
- temperatura de lucru: 0°C ÷ +40°C;
- temperatura de depozitare: -20°C ÷ +70°C;
- baterie 1,5V oxid de argint (SR44)
- lampa de control nivel încărcare baterie.
- livrabil in etui de plastic cu baterie de rezerva (2000 ore/an).

Umidometru

Art. Nr. 714 641 11



- masoara umiditatea de la 7% la 35% prin introducerea a doi punctatori ascutiti 2÷3 mm in material;
- baterie de 9 V inclusa;
- precizie: 1 %;
- dimensiuni: 135 x 43 x 21 mm;
- greutate: 110 g;

Detector MD10

Art. Nr. 714 641 300

- detector digital pentru localizare metal, lemn sau cabluri electrice
- calibrare automata
- zoom pentru localizare precisa
- ecran cu rezolutie inalta
- eliminarea ambiguitatii la gaurire prin intermediul LED-ului rosu / verde
- mariale detectabile: armatura, otel, metale neferoase, lemn, cabluri electrice active sau pasive
- localizare tevi apa (cupru)

Menghina pentru strangere sau distantare Menghine de mana

- strangere sau distantare pas cu pas utilizand o singura mana
- prin schimbarea pozitiei unuia din bacuri poate fi utilizata pentru distantare
- avans rapid in faza de apropiere, cuplare automata, forta mare
- maner ergonomic
- bacuri din material plastic armat cu fibra de sticla
- introducerea sistemului de schimbare rapida
- imbunatatirea manerului 2k
- cresterea fortei pana la 150 kg
- cresterea adancimii bacului la 100 mm.



L _{max} mm	L ₂ mm	L ₃ mm	B mm	L ₁ max	Art.-Nr.	
150	100	6	20	40	714 662 150	1
300	100	6	20	580	714 662 300	
450	100	6	20	710	714 662 450	
700	100	6	20	960	714 662 700	
Bacuri de schimb					714 661 1	2

- sina profilata, cu 6 suprafete striate, zincata galvanic
- capace de protectie din material plastic
- brate solide din fonta maleabila
- surub brunat, cu filet trapezoidal
- maner din lemn, lustruit, nituit.



Deschidere mm	Lungime brate mm	Sina mm	Capace protectie	Art. Nr.	UA.
250	100	27 x 7	X	714 672 25	
250	120	29 x 9	X	714 671 25	
400	120	29 x 9	X	714 672 40	
500	120	29 x 9	-	714 671 500	
500	120	35 x 11	-	714 671 50	
600	120	29 x 9	-	714 671 600	
600	120	35 x 11	-	714 671 60	
1000	120	29 x 9	-	714 671 101	
1000	120	35 x 11	-	714 671 100	1
1250	120	35 x 11	-	714 671 125	
1500	120	35 x 11	-	714 671 150	
1800	120	35 x 11	-	714 671 180	
2000	120	35 x 11	-	714 671 200	
2200	120	35 x 11	-	714 671 220	

Pentru alte dimensiuni consultati catalogul general

Cutter cu magazie

Art. Nr. 715 66 271

Lama de schimb
Art. Nr. 715 66 05



Nivela PLUMBSITE®



- material: profil de aluminiu nedeformabil
- manere laterale.
- fiole cu bula executate din acril rezistent la socuri, fixate rigid in casetele incastrate in profilul de aluminiu.

Dimensiune cm	Tip	Art.-Nr.	UA.
60	-	715 643 516	
80	-	715 643 518	1
100	-	715 643 511	

Panze pendular

*** – performante bune pentru utilizari extreme, cu durata mare de viata

** – foarte bune pentru aplicatii grele

Material	Prindere	Calitate	Art.-Nr.	VE/St.		Design	Pas mm	Lungimea totala mm	Lungime activa mm	Grosime mm
Constructii		***	608 116 345	1=5		Bimetal progresiv	2,4-5	132	105	125
Lemn		***	608 116 234	1=5		HCS progresiv	2-3	117	90	135
		**	608 116 112	1=5		HCS ascutit si conic rectificat	1,3	82	57	10
		**	608 116 111 ²	1=5		HCS ascutit si conic rectificat	2,5	100	75	135

! Scule aschietoare

Burghiu spiral HSS DIN 338 N, scurt

Art.-Nr. 624 00....



- burghiu de inalta calitate, rectificat, din otel rapid de inalta performanta (HSS) M2.
- utilizare universala pentru oteluri de pana la 1000 N/mm²
- satisfac cele mai inalte cerinte de precizie si durabilitate.
- special pentru masini manuale de gaurit.

Set burghie HSS

Art.-Nr. 625 1

Continut: Ø 1,0 – 10,0 x 0,5 mm, 19 piese



Dimensiuni uzuale *			Art. Nr.	Art. Nr.
D mm	L 1 mm	L 2 mm	624 ...	625 ...
3,00	61	33	624 000 300	625 30
3,50	70	39	624 000 350	625 35
4,00	75	43	624 000 400	625 40
4,50	80	47	624 000 450	625 45
5,00	86	52	624 000 500	625 50
5,50	93	57	624 000 550	625 55
6,00	93	57	624 000 600	625 60
6,50	101	63	624 000 650	625 65
7,00	109	69	624 000 700	625 70
7,50	109	69	624 000 750	625 75
8,00	117	75	624 000 800	625 80
9,00	125	81	624 000 900	625 90
10,00	133	87	624 001 000	625 100
11,00	142	94	624 001 100	625 110
12,00	151	101	624 001 200	625 120

* Pentru celelalte dimensiuni intermediare consultati catalogul general.

	338 N scurt	HSS	625 ...	↑	↓	↑	↓	↓	↓	↓	↓	↓	↓	↓	↓	↓	↓	cca. 5 x 18°	Conică	12,7 de la Ø 13,0	10 - 20,0								
	338 N scurt	HSS	624 00 ...	↓	↓	↓	↓	↓	↓	↓	↓	↓	↓	↓	↓	↓	↓	cca. 5 x 18°	Conică	12,7 de la Ø 13,0	0,5 - 20,0								
Nerecomandat Utilizare după încercări Utilizare foarte bună	DIN / Tip	Material	Cod articol	Domeniu	aplicare	Exemple	Oteluri speciale	Otel inoxidabil	Oteluri rezistente temperaturi	Fontă	Titan	Oteluri aliate Ni-Cr	Plastic dur (Duroplast)	Plastic moale (Termoplast)	Metale neferoase	Placi gips-carton	Lemn	Materiale pe baza de polimeri	Date tehnice	Caracteristici	Adâncime gaură	Unghi la varf	Mod ascuțite	Diametru coadă	Acoperire	Rezistența otelului	Diametru		
						S12 - S14 S34 - S70. Bare profilate, cazane	Oteluri automate, imbunzatile, structuri rezistente	VA2, VA4. Oteluri rezistente la acizi		Censușie, modulara, metalobita	Titan, aliaje pe baza de titan	Nimonic, Hastelloy, Inconel, Monel	Bachelita, Perlinax, Resopal	PA, PE, PP, PVC, sticla acrilica, Plexiglas	Aluminiu, cupru, alumă	Placi gips-carton, placi gips, placi liant de ciment	Lemn de esență tare și moale, placi aglomerate	Corian, Marlan, Vancor				Burghiu-Ø	Grade	Forma	mm		mm		

Zencuitoare conice pentru burghie

- se poate folosi de asemenea și ca limitator de adâncime

Art. nr.	Diametru
650 7...	3, 4, 5, 6, 8, 10.



Freza HW dreapta

- cu varf de centrare, 2 dinti si 2 muchii principale
- se foloseste pentru executarea de gauri curate si precise in orice tip de lemn (ex: frezari pentru repararea nodurilor, frezari pentru demontabili, balamale etc.)
- lungime totala 90 mm
- diametrul cozii 10 mm

Art. nr.	Diametru
650 1 ...	15, 20, 25, 30, 35



Panze de circular cu unghi pozitiv de taiere Freze HM pentru gauri de balama

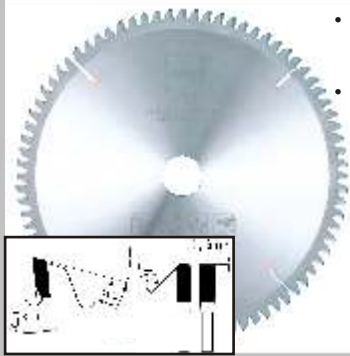

- panza circulara speciala pentru obtinerea unor taieturi optime cu suprafete bune pe ambele parti taiat.
- cu dinti trapezoidali si drepti, indicate pentru taieturi longitudinale, taieri profile.

Dimensiuni mm	Nr. dinti	Art.-Nr.
250 x 3.2 x 30	Z=60	611 025 602
350 x 3.2 x 30	Z=80	611 025 802
300 x 3.2 x 30	Z=96	611 030 962
400 x 3.2 x 30	Z=96	611 240 962



Art. nr. 650 035
Diametru 35 mm,
Lungime totala 70 mm,
Diametrul cozii 10 mm,



Art. nr. 682 100 113
Diametru 35 mm,
Lungime totala 57 mm,
Diametrul cozii 10 mm,

Accesorii protectia muncii

Manusi pentru mecanici

- proprietati excelente de aderenta,
- rezistenta mecanica mare
- utilizare in domeniul constructiilor, atat la operatii exterioare cat si la interior
- ideale pentru operatii de sortare, impachetare si manipulare in depozite



Dimensiuni	Art.-Nr.	U.A./pereche
8	899 400 529	1/6
9	899 400 530	
10	899 400 531	

Manusi de unica folosinta Nitril

- rezistenta chimica buna la agentii comuni utilizati in industrie (inclusiv adezivi si lacuri)
- utilizare la operatia de vopsire



Dimensiuni	Art.-Nr.	U.A./pereche
M	899 470 01	100
L	899 470 02	
XL	899 470 03	

Semimasca HM 173

Art. Nr. 899 173 (livrare fara filtre)



- utilizare la ateliere vopsitorii si laboratoare chimice, la manipularea solventilor etc

Ochelari de protectie Libra

Art. Nr. 899 102 270

- lentile tratate pe ambele parti: la exterior protectie antizgariere, iar la interior protectie permanenta antiaburire
- culoare transparenta, protectie UV 100%.
- respecta normele EN166 si EN170



Casti protectie fonica

Art. Nr. 899 300 210

- protejeaza fonic pana la 27 dB
- greutatea 150 g



Testat conform EN352

SNR	L	M	H
23 dB	13 dB	20 dB	27 dB

Masca praf FFP 1

Art. Nr. 899 124 1



- masca standard pentru filtrarea aerului inhalat, fara ventil de expirare
- ideala in cazul slefuirii lemnului sau a altor materiale cu proprietati similare

Produse chimice

Curatitor concentrat pentru rasina

HEK 5000

Art. Nr. 893 611 (continut 5 l)

- pentru curatarea rapida a panzelor de ferastrau circular manual si stationar, a cutitelor de rindea, a capetelor de frezare.
- se dilueaza cu apa in raport 1:2.
- pentru curatare se foloseste pensula de nylon sau material plastic sau se scufunda piesa intr-o baie de lichid si se freaca cu peria.
- in scurt timp depunerile de rasina si impuritati sunt dizolvate; suprafetele se curata prin stergerea cu carpa.



Solutie pentru neutralizarea rasinii

HOLZGLEIT

Art. Nr. 893 070 (continut 5 l)

- evita lipirea aschiilor si rumegusului pe mosina de prelucrat lemnul,
- nu se aplica pe suprafata lemnului (se pulverizeaza pe componentele masinii)
- curata rotile de reglaj, surubul conducator al masinii, instrumentele de masura.



Curatitor industrial

Curatitor special pentru industrie si ateliere

Art. Nr. 893 140 (spray 500 ml)

Art. Nr. 893 140 05 (continut 5 l)

- indeparteaza resturile de adeziv de la benzi adezive si etichete din plastic sau hartie. Curata utilajele, componentele din plastic precum si suprafetele metalice.
- dizolva diversele tipuri de markere (ex. Edding) de pe suprafetele netede, neabsorbante. Curata urmele de degete pentru pre-curatarea suprafetelor inaintea lipirii.



HHS precuratitor

Art. Nr. 893 106 10 (continut 500 ml)

- pentru pretratarea partilor foarte murdare care urmeaza sa fie lubrificate, de exemplu: vaselina invecitata murdara, resturi de ulei, ceara etc.
- capacitate mare de curatare
- imbunatateste aderenta lubrifiantului (gama HHS)
- reduce costurile si timpul



Degripant ROST - OFF PLUS

Art. Nr. 890 200 (spray 300 ml)

- proprietati de degripare si ungere datorita noii tehnologii OMC2.
- pentru demontarea suruburilor foarte ruginite la utilaje, echipamente, autoturisme,
- compatibilitate cu cauciucul si materiale plastice, componentele din plastic precum si suprafetele metalice.



Detergent pentru parbriz

Art. Nr. 892 332 840 (continut 1 l)

- pentru a se asigura o pulverizare optima pe parbriz pana la -15°C, se recomanda diluarea cu apa 1:1.



Detergent pentru maini

Art. Nr. 893 900 0 (continut 4 l)

- curata foarte rapid si in profunzime, nu necesita frecarea intensa a mainilor.
- protejeaza si intretine pielea datorita continutului de Dermatol.



Rola prosoape de hartie

Art. Nr. 899 800 773
(2 straturi, 39 x 38 cm, 1000 buc)

- foarte absorbante,
- se potriveste cu toate modelele uzuale de suport.



Adeziv pentru lemn D3/D4

Adeziv pe baza de dispersie, calitate D3 / D4
dupa adaugarea intaritorului.
Art. Nr. 892 100 14 (continut 12 l)
Art. Nr. 892 100 15 (continut 30 l)

- se poate utiliza in interior, putând exista contact ocazional cu apa sau condensul, ca si in exterior dar neexpus intemperiilor
- usi interioare, trepte si balustrade, mobilier de baie si bucatarie.
- lipiri pe suprafete mari, rosturi, lemn masiv.
- masini stationare de lipit pe cant a furnirului, a stinghiilor.
- lemn de esenta tare, moale sau exotic.



Banda adeziva pentru oglinzi

Pe suport de PE si adeziv pe baza de acrilat

Utilizata la:

- fixarea oglinzilor
- fixarea traverselor la ferestre
- fixarea obiectelor sanitare
- fixarea agatatorilor
- banda este recomandata pentru lipirea diferitelor materiale precum lemn, metal, sticla, piatra, precum si Plexiglas si Makrolon (nu provoaca tensiuni)



Culoare	Latime in mm	Lungime in mm	Grosime in mm	Art.-Nr.
Alba	19	25	1	894 918 0
Alba	25	25	1	894 918

Adeziv universal foarte puternic

Art. Nr. 893 100 110 (continut 310 ml, bej)

Adeziv poliuretanic pentru lipire:

- tablii de usi, balustrade, trepte, plinte, prelucrarea pietrei, ferestre metalice, glafuri, placari, diverse operatiuni de montaj si reparatii
- pentru lipirea diverselor materiale: lemn, metal, aluminiu vopsit, PVC dur, beton, piatra naturala, Corian, Varicolor, materiale stratificate, ceramica, spume dure de rasina fenolica si poliuretan



KLEBFIX adeziv pe baza de cianacrilat

Art. Nr. 893 090 (continut 50 g)

- pentru lipirea partilor metalice, plastice si din cauciuc in orice combinatie,
- indicat pentru reparatii rapide.



Adeziv universal pe baza de Neopren

Art. Nr. 893 100 023 (continut 730 ml)

Pentru lipire:

- placi de lemn, placi aglomerate, placi furniruite, placaj dur, placi decorative
- placi din materiale stratificate (Resopal, Duropal, Ultrataps)
- placi din materiale plastice
- PVC dur, PMMA, poliester, poliamida, policarbonat,
- spume tari pe baza de rasini fenolice si poliuretan
- cauciuc, pasla, textile, piele, metal etc



Etansant

pentru etansarea imbinarilor filetate in sistemele pneumatice si hidraulice supuse la presiuni mari

Art. Nr. 893 545 050 (continut 50 g)

- poate fi aplicat si pe suprafetele usor uleioase
- rezistenta excelenta la toate fluidele hidraulice
- intarire rapida chiar la temperaturi joase, rezistenta la demontarea cu mana dupa 40 de minute
- imbinarile pot fi solicitate dupa 2-3 ore



Spuma poliuretanică pentru pistol

Art. Nr. 892 152 01 (continut 750 ml)

Spuma poliuretanică pentru iarna
Art. Nr. 892 152 02 (continut 750 ml)

- aderență foarte bună pe majoritatea materialelor de construcții precum lemn, beton, cărămizi, metal, aluminiu
- proprietăți bune termo și fonoizolatoare
- avantaje: dozare exactă (consum redus) și nu se întărește la întreruperea lucrului



Silicon neutral

- etansant permanent elastic
- folosit pentru etansarea diferitelor materiale ca: sticla, lemn, ceramica, aluminiu, majoritatea materialelor plastice



Cantitate	Culoare	Art. Nr.	U.A.
310 ml	Transparent	892 310 1	1/20
	Alb	892 310 2	

Chit pentru lemn

Pe baza de nitroceluloza

- pentru astuparea gaurilor si fisurilor adanci, de exemplu gaurile pentru suruburi, noduri, crapaturi in toate tipurile de lemn masiv si furnir din lemn.



Culoare	Cutie	Art. Nr.	U.A.
Natur	250 g	890 304 0	1/6
Stejar, deschis		890 304 1	
Stejar, inchis		890 304 2	
Fag		890 304 7	

Ceara retus

Trusa nuante maro Art. Nr. 964 890 4

- pentru astuparea fisurilor, striatiilor, gaurilor, adanciturilor, rosturilor care nu sunt supuse la sollicitari mari
- nuantele se pot amesteca
- pentru completarea trusei se pot livra si batoane individual (pentru cod consultati pagina de catalog)



HHS 2000

Ulei semisintetic rezistent la presiuni foarte mari Art. Nr 893 106 (continut 500 ml)

- recomandat pentru lubrifierea universala si a partilor supuse la presiuni mari, ex: schimbator viteze, pedala acceleratie si ambreiaj, balamale, glisiere etc.



HHS DRYLUBE

Ceara sintetica uscata continand PTFE rezistenta la forta centrifuga Art. Nr 893 106 6 (continut 400 ml)

- recomandata pentru lubrifierea elementelor cu rotatie rapida, ex: lanturi si organe de masini, cabluri de frane din otel, lanturi de motocicletă etc.



Ulei special pentru scule pneumatice

Art. Nr 893 050 5 (continut 1 l)

- excelenta protectie anticoroziva si antiuzura.
- este eficient si la temperaturi scazute.



Vaselina universala tip I

Art. Nr 893 870 1 (continut 400 g)

- unsoare universala pe baza de uleiuri minerale si litiu saponificat
- pentru subansamble care sunt supuse unor sollicitari mici: rulmenti, arbori etc.
- rezistenta la oxidare
- isi pastreaza proprietatile de etansare si respinge mizeria si praful



Ulei pentru compresor WK100

Art. Nr 893 050 506 (continut 1 l)

- pentru lubrifierea compresoarelor cu piston si rotative pana la o temperatura de compresie de 220° C
- recomandat si pentru lubrifierea rulmentilor la turbocompressoare
- conform DIN51506, categoria VDL



Presa manuala pentru gresat

Art. Nr 986 00

- pentru cartuse cu vaselina de 400 g
- permite controlul cantitatii aplicate de vaselina
- utilizare usoara, design ergonomic



Masini electrice si pneumatice

Bormasina cu acumulatori BS 12-A Solid

Art. Nr. 700 183 3

- acumulator compact, de mare capacitate, lunga durata de folosire.
- rezistenta la utilizare indelungata in regim dur de lucru fata de alte produse similare in gama de 12V.



Tensiune	12 V
Putere	300 W
Capacitate acumulator	2,0 Ah
Turatii	0 - 400/1,350 rpm
Cuplu reglabil	0,5 - 10,0 Nm
Cuplu maxim	45 Nm
Capacitate max. de gaurire in metal/aluminiu/lemn	13 mm/16 mm/38 mm
Capacitate recomandata de gaurire in metal/aluminiu/lemn	10 mm/13 mm/32 mm
Ø max. al surubului	8 mm
Ø recomandat al surubului	6 mm
Gama de prindere mandrina	1,5 - 13 mm
Sistem de prindere mandrina	1/2"-20 UNF
Greutate fara acumulator	1,7 kg
Greutate	0,7 kg

Pachetul de livrare cuprinde doi acumulatori, valiza incarcator rapid 30 minute, cutie cu biti.

Masina de insurubat Li-Ion accu

Art. Nr. 700 653 2

- 20 + 1 pozitii pentru preselectia momentului de torsiune.
- mandrina rapida pana la 10 mm.
- lampa "Power Light" - pentru vizibilitate, intrerupator pornit/oprit cu reglarea vitezei,
- comutator insurubare - gaurire = moment optim, viteza optima.
- Li-Ion fara efect de memorie si fara autodescarga.



Tensiune:	10,8 V
Capacitate acumulator:	1,3 Ah Li-Ion;
Turatie:	0-400/1100 rpm;
Cuplu maxim:	30 Nm;
Diametrul maxim de gaurire:	- metal: 10 mm - lemn: 19 mm;
Gama prindere mandrina:	1-10 mm;
Sistem prindere mandrina:	1/2" - 20 UNF;
Greutate cu acumulator:	1,1 kg;

Livrabila cu 2 acumulatori!

Masina de gaurit si insurubat BM10-XE

Art. Nr. 702 325 0

- masina de gaurit puternica 650 Watt pentru gaurire in lemn, plastic si metal.



Alimentare	230 V AC
Frecventa	50/60 Hz
Clasa de protectie	□/ II
Putere absorbita	650 W
Putere debitata	345 W
Turatie la mers in gol	0 - 3.150 rpm
Mandrina	1 - 10 mm
Moment maxim*	10 Nm
Greutate	1,5 kg
Lungime cablu	4 m

*) Momentul maxim poate fi solicitat numai pe perioade scurte.

Masina de gaurit si insurubat H26-MLE

Art. Nr. 702 226 1

- foarte rapida
- forma ergonomica
- usoara si compacta
- 36 de pozitii de reglaj ale daltii
- decuplare automata a carbonilor



Tensiune de alimentare	230 V/50 Hz
Clasa de protectie	□/II
Puterea absorbita	800 watt
Turatie la mers in gol	0-1,300 rpm
Numar de lovituri in gol	0-4,000 rpm
Fora loviturilor individuale	0-3,0 Joules
Diametrul gatului arborelui	50 mm
Cuplu de siguranta	28 Nm
Lungimea cablului	4 m
Greutate	2,7 kg

Surubelnita cu acumulator S10A Power

Art. Nr. 700 662 1

- foarte compacta, masina de inalta performanta cu acumulator de 10 W Li-Ion ideala pentru suruburile de conexiune mai mari de 6 mm



Tensiune	10,8 V
Turatii	0-500 rpm
Capacitate acumulator	1,3 Ah
Dimensiuni	176 x 167 mm
Cuplu maxim reglabil	7 NM
Cuplu maxim de gaurire	18 Nm
Cuplu de lucru	10+1
Sistem de prindere in mandrina	11/4"
Greutatea cu acumulator	0,8 kg

Pistol pneumatic de insurubat DPS1/4

Art. Nr. 703 412

- mandrina rapida pentru bit 1/4"
- rotatie in ambele sensuri, moment reglabil
- control fin al turatiei



Antrenare hexagon	1/4"
Moment maxim Nm	10
Turatie min ⁻¹	1800
Presiune medie lucru bar	6,3
Greutate Kg	1,5
Lungime mm	184
Debit de aer l/min.	85
Filet de legatura	R 1/4"
Diametru minim furtun	9

Ferastrau pendular STP 135-B exact

Art. Nr. 702 646 1

- vibratia bratului in miscare
- talpa pendular reglabila



Putere absorbita	720
Turatie min ⁻¹	500 - 2800
Greutate kg	2,7
Lungime cablu m	4
Inclinatie panza	0 ÷ 45°

Polizor unghiular EWS 115ES

Art. Nr. 702 471 0

- masina puternica, usor de manuit, pentru slefuit, taiat si degrosat
- inglobeaza cele mai noi inovatii din domeniu.



Alimentare V/Hz	220V / 50Hz
Clasa de protectie	II / II
Putere nominala W	800
Putere absorbita W	500
Turatie la mers in gol min ⁻¹	11000
Ø max. disc mm	115
Prindere M	14
Lungime cablu m	4
Greutate Kg	1,9

Ciocan pneumatic pentru cuie DSK1555

Art. Nr. 703 547 0

- deosebit de usor si comod de utilizat, pentru cuie cu diametrul 1,2 mm si lungime 15 - 54 mm
- utilizari recomandate: la baghete de usi, elemente de perete, baghete profilate, ornamente, profile decorative, baghete decorative, pervaz pentru usi etc.



Diametru cuie	1,2 mm
Lungime cuie	15-54 mm
Capacitate magazie	105 cuie
Presiune de lucru	4,8-8,3 bar
Presiune maximă	8,3 bar
Consum aer	cca. 113 l / bătăie
Diametru minim furtun	6 mm
Legătură	R 1/4"
Greutate	1,09 kg
Dimensiuni	241 x 67 x 245 mm

Dimensiuni	Art. Nr.
12,8 x 25 mm	480 12 250
12,8 x 30 mm	480 12 300
12,8 x 38 mm	480 12 380

Pistol pneumatic de însurubat DSS1/2

Art. Nr. 703 735

- putere mare, momentul max al fortei - 565Nm
- moment de pornire reglabil in 4 trepte, momentul de desfacere este intotdeauna maxim
- sistemul de inversare permite utilizarea cu o singura mana.
- angrenaj percutor performant, ajunge rapid la momentul maxim si lucreaza aproape fara vibratii, chiar si in sarcina,
- angrenajul percutor functioneaza in baie de ulei = durata de viata ridicata.



Antrenare patrata	1/2"
Moment de lucru Nm	420
Moment de pornire max.	470
Presiune medie lucru bar	6,3
Greutate Kg	2,3
Lungime mm	187
Debit de aer l/min.	108
Filet de legătură	R 1/4"
Diametru min. furtun	9

Capsator pneumatic DKG416

Art. Nr. 703 548 0

- foarte usor, puternic pentru lucru cu clame late de 12,8 mm, lungime 4 - 16 mm
- utilizare pentru furnituri, ambalaje, bariere de vapori, membrane, izolatii, industria de mobila.



Denumire	DG 416
Lătime clame1	2,8 mm
Lungime clame	4-16 mm
Capacitate magazie	157 clame
Presiune de lucru	4-7 bar
Presiune maximă	7 bar
Consum aer	cca. 0.3 l / bătăie
Diametru minim furtun	6 mm
Legătură	R 1/4"
Greutate	0,7 kg
Dimensiuni	238 x 42 x 152 mm

Dimensiuni	Art. Nr.
12,8 x 8 mm	480 129 080
12,8 x 14 mm	480 129 140
12,8 x 16 mm	480 129 160

Compresor K210

Art. Nr. 701 221

- compresor mobil pentru utilizare profesionala atat in domeniul constructiilor cat si in ateliere

Tensiune	V/Hz	230 / 50
Clasa protectie / tip		II / II
Putere motor*	kW	1,5
Turatie	rpm	2.850
Volum ulei/conform DIN 51506	l	0.2/ISO 100
Presiune maxima	bar	8
Debit de aer absorbit	L/min.	185
Debit de aer furnizat la 7 bari	L/min.	105
Capacitate rezervor	l	9,5
Nivel zgomot	dB (A)	79
Temperatura de lucru	°C	+5 to +40
Dimensiuni (L x W x H)	mm	400 x 320 x 630
Greutate	kg	18

* Puterea generatorului de curent trebuie sa fie de 4-5 ori mai mare.





WÜRTH ROMANIA S.R.L.
Str. Drumul Garii Otopeni, Nr. 25-35
Otopeni – Jud. Ilfov
Tel. 021 - 300.78.00; 300.78.01
Fax. 021 - 350.45.92. 350.45.93
office@wuerth.ro
www.wuerth.ro

