

Attenuator Data Sheet

The CT2 Audio Volume Controls are high quality stepped 24-position attenuators. Designed for maximum sonic quality, accuracy and reliability. This makes them equally suited for audiophile and professional applications. Available as master volume control with 60dB attenuation range (1, 2, 4, 8, 8 decks) and as individual channel fine adjustment (CT2-10k-1/fine) with 0.5dB level change between each step (only available with 1 deck). Their series resistor networks consist of 23 non-inductive, low noise, SMD metal film resistors. The layout of the PCB Boards and the choice of SMD resistors have reduced the signal path to a minimum length (typical five times shorter than conventional stepped attenuator designs with leaded resistors). The PCB design combined with the special resistors also account for the very low series inductance and the very low stray capacitance. The result is a bandwidth beyond even the most demanding audiophiles' requirements. There has been special care taken to ensure the durability of CT2. Therefore, all contacts and PCB traces are gold plated to prevent any corrosion. As a result, the CT2s will maintain their specifications after long time of use even in hot and humid environments.

FEATURES

- Low noise, non-inductive, metal film SMD resistor network
- Compact design
- Entire signal path gold plated
- Shorter signal path than conventional attenuators with leaded resistors
- Reduced inductance and stray capacitance
- Improved sonic quality
- Improved accuracy - 0.05dB tracking and 0.05dB attenuation accuracy
- Improved reliability
- Increased bandwidth
- Reduced distortion, less than 0.0001%

SCHEMATIC

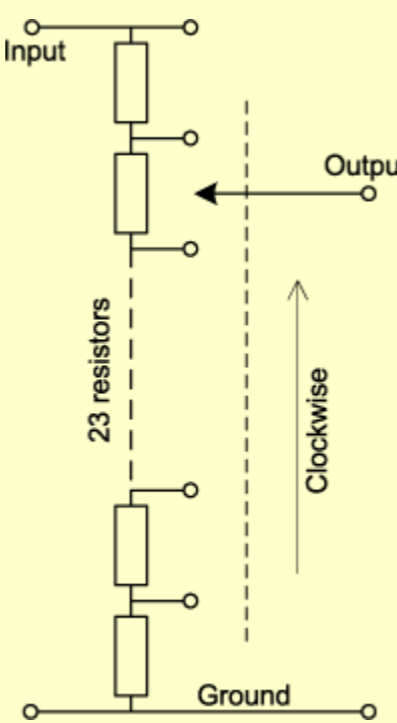

SPECIFICATIONS

MAXIMUM RATINGS

Note	Parameter	Conditions/comments	Value	Unit
1	Switching capacity	(resistive load)	2V/2A 24V/0.6A 42V/0.4A	AC/DC
1	Power dissipation	(each resistor)	100	mW
1	Operating ambient temp. range		-25 to +70 (-13 to +158)	deg. C (deg. F)
1	Storage temperature range		-40 to +85 (-40 to 185)	deg. C (deg. F)

[To the top](#)

MECHANICAL CHARACTERISTICS

Note	Parameter	Conditions/comments	Value	Unit
	Number of positions		24	
	Indexing angle		15	deg.
	Switching function		shorting	
	Gold plating, contacts	(hard-gold)	3	µm
	Gold plating, wiper	(hard-gold)	8	µm
2	Mechanical life		>25,000	cycles
	Switching torque	1-, 2-, and 4-decks versions 6- and 8-decks versions	1.5 3.5	Ncm Ncm
	Nut tightening torque		max. 300	Ncm

DC ELECTRICAL CHARACTERISTICS

Note	Parameter	Conditions/comments	Value	Unit
	Total resistance range	(standard versions of CT2)	10, 20, 50, 100, 250, 500	kOhm
		(fine-adjustment version)	10	kOhm
3	Total resistance accuracy	(new)	0.1	%
	Attenuation steps, standard version	(source output impedance = 0), (load input impedance = infinite)	0, 2, 4, 6, 8, 10, 12, 14, 16, 18, 20, 22, 24, 26, 28, 30, 32, 34, 38, 42, 46, 50, 60, infinite	dB
	Attenuation steps, version for fine-adjustment	(source output impedance = 0), (load input impedance = infinite)	0, 0.5, 1, 1.5, 2, 2.5, 3, 3.5, 4, 4.5, 5, 5.5, 6, 6.5, 7, 7.5, 8, 8.5, 9, 9.5, 10, 10.5, 11, 12, infinite	dB
3	Attenuation accuracy	(new)	+/- 0.05	dB
3	Matching accuracy (tracking)	(between two decks)	+/- 0.05	dB
4	Contact resistance	(new)	max. 0.01	Ohm
	Contact capacitance	(adjacent contacts)	1	pF
	Series inductance	(10 kOhm, input to ground)	max. 0.4	µH

AC ELECTRICAL CHARACTERISTICS

Note	Parameter	Conditions/comments	Value	Unit
4	-3dB bandwidth	(10k, A = -6dB)	50	MHz
5	Noise voltage	(10k, input to ground pin)	12.8	nV/Hz
6	Total harmonic distortion	(A = -6dB, fo = 1kHz)	max. 0.0001	%

Notes

- 1 Exposure to maximum rating conditions for extended periods of time may affect device reliability
- 2 One cycle is defined as a full rotation from one end stop to the other and return
- 3 Typical values at +25 deg. C ambient temperature. Output (pin 2) unloaded
- 4 Measuring probe input capacitance 1 pF
- 5 Theoretical value for an ideal 10k resistor
- 6 Measured with Panasonic Audio Analyzer VP-7722P

[To the top](#)

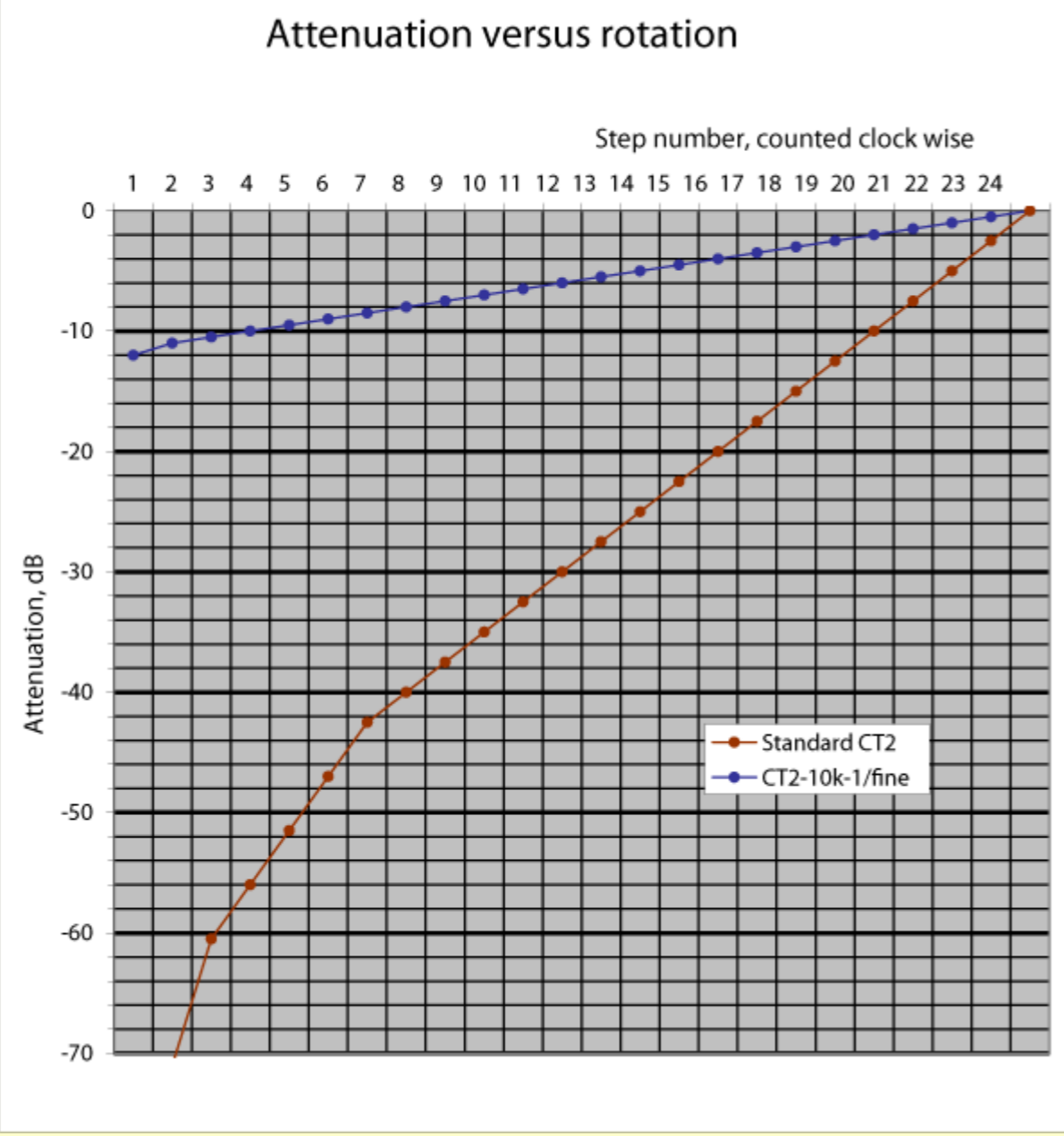

OUTLINE DRAWING

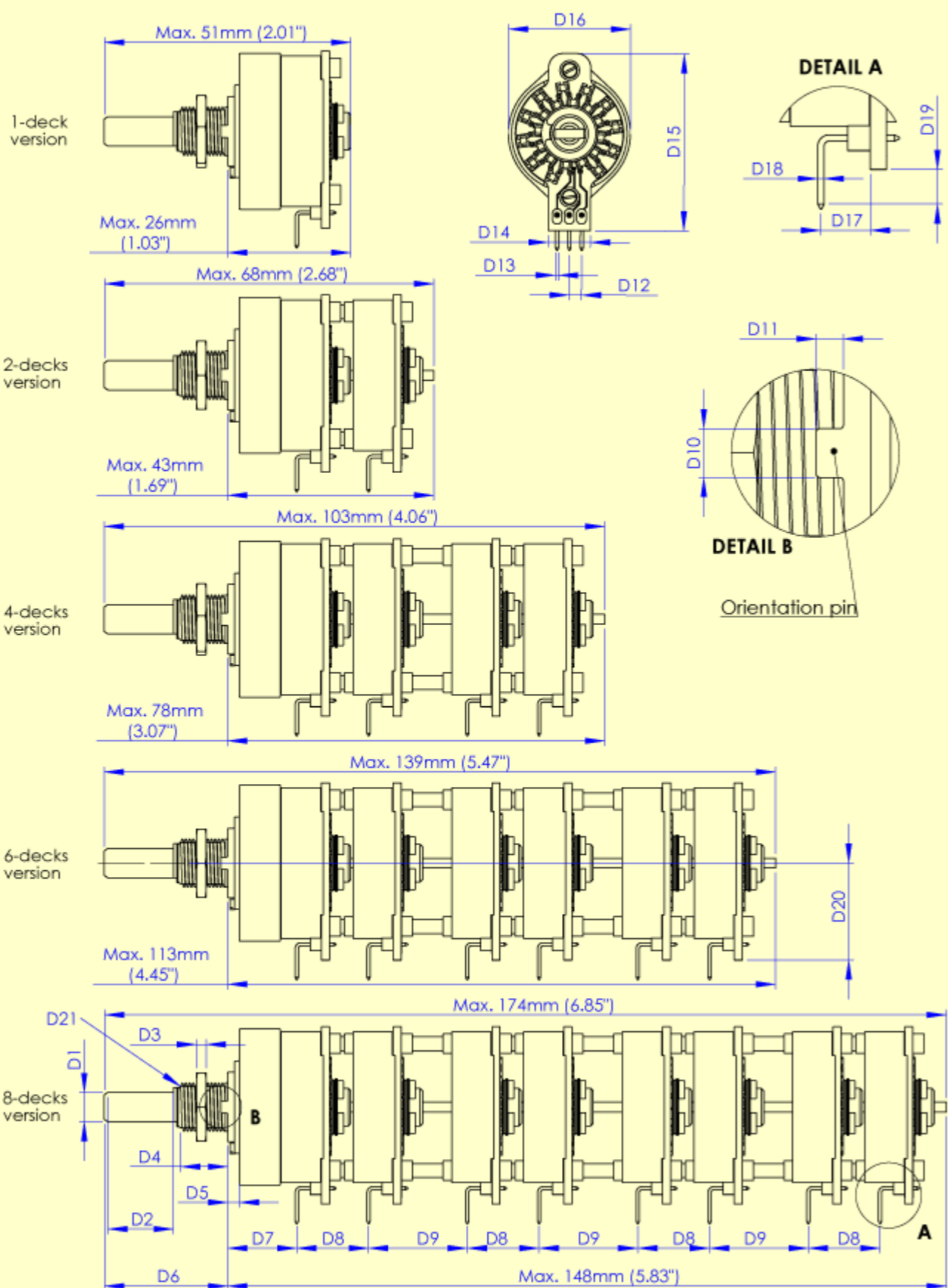

[To the top](#)

NOMINAL DIMENSIONS

Dimensions common for all models

Dim.	Description	Number
D1	Shaft diameter	6.0mm (0.236")
D2	Shaft length	14.5mm (0.57")
D3	Nut thickness	2.5mm (0.10")
D4	Thread length	9.5mm (0.37")
D5	Distance	2.5mm (0.10")
D6	Distance	25mm (0.98")
D7	Distance to terminals	13.2mm (0.52")
D8	Distance 1 between terminals	14.7mm (0.58")
D9	Distance 2 between terminals	20.2mm (0.80")
D10	Orientation pin width	2.5mm (0.10")
D11	Orientation pin height	1.3mm (0.05")
D12	Distance between terminal pins	2.54mm (0.10")
D13	Terminal pin width	0.64mm (0.025")
D14	PCB bottom width	8.7mm (0.34")
D15	Total height when mounted in PCB	36.5mm (1.44")
D16	Maximum width	25mm (0.98")
D17	Terminal distance to PCB	6.0mm (0.24")
D18	Terminal pin thickness	0.64mm (0.025")
D19	Terminal pin length below PCB	3.5mm (0.14")
D20	Distance from PCB bottom to shaft center	19.9mm (0.783")
D21	Thread type	M10 x 0.75

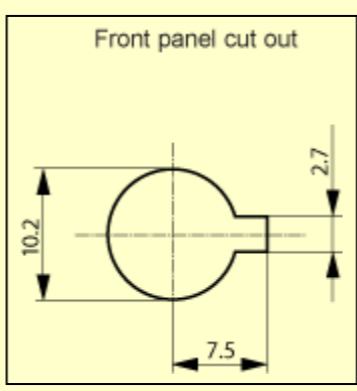

CONNECTIONS

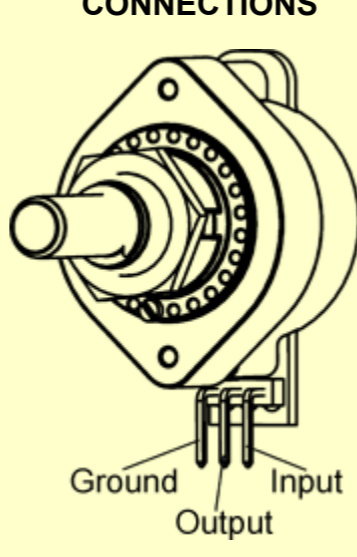

[To the top](#)

ORDERING INFORMATION

Part number	Description
CT2-10k-1/fine	1-channel stepped attenuator, fine adjustment (0.5dB steps)
CT2-xxxk-1	1-channel stepped audio attenuate (mono)
CT2-xxxk-2	2-channel stepped audio attenuate (stereo)
CT2-xxxk-4	4-channel stepped audio attenuate (balanced stereo)
CT2-xxxk-6	6-channel stepped audio attenuate (AV audio)
CT2-xxxk-8	8-channel stepped audio attenuate (AV audio)

xxx refers to the attenuator resistance. Available resistances are 010 (10kOhm), 020 (20kOhm), 050 (50kOhm), 100kOhm, 250kOhm, 500kOhm

RELATED PRODUCTS

Part number	Description
CT-ext1/S	Shaft extension kit, 200mm long extension shaft
CT-ext1/L	Shaft extension kit, 400mm long extension shaft
CT-conn1	Wire/connector kit including wires
CT-knob1/steel	25mm stainless steel knob
CT-knob2/steel	30mm stainless steel knob
CT-knob3/steel	38mm stainless steel knob
CT-knob4/steel	50mm stainless steel knob
CT4-25k-2 CT4-250k-2	Balance controls, 25kOhm and 250kOhm versions

[To the top](#)

