



Technický a skúšobný ústav stavebný, n. o.
Building Testing and Research Institute
Studená 3
821 04 Bratislava
Slovak Republic
Phone: +421 2 49228101
E-mail: sternova@tsus.sk
Website: www.tsus.sk



European Technical Assessment

ETA 20/0488 - version 01
of 23/06/2020

General Part

Technical Assessment Body issuing the ETA and designated according to Article 29 of the Regulation (EU) No 305/2011: **Technický a skúšobný ústav stavebný, n. o.**

Trade name of the construction product

TERAJOINT® and TERAJOINT® Strong

Product family to which the construction product belongs

Product area code: 20
Structural Metallic Products and Ancillaries

Manufacturer

Peikko Group Oy
Voimakatu 3
15170 Lahti
Finland
<http://www.peikko.com>

Manufacturing plant

Peikko production units

This European Technical Assessment contains

12 pages including 6 annexes which form an integral part of this assessment.

No annex contains confidential information

This European Technical Assessment is issued in accordance with regulation (EU) No 305/2011, on the basis of
This version replaces

EAD 200089-00-0302

—

Translations of this European Technical Assessment in other languages shall fully correspond to the original issued document and should be identified as such.

Communication of this European Technical Assessment, including transmission by electronic means, shall be in full (excepted the confidential Annex(es) referred to above). However, partial reproduction may be made, with the written consent of the issuing Technical Assessment Body – Technický a skúšobný ústav stavebný, n. o. (TSÚS). Any partial reproduction has to be identified as such.

Specific part

1 Technical description of the product

The ETA covers TERAJOINT[®] and TERAJOINT[®] Strong free movement joints produced from the following main components:

1. Divider plate made of steel DX51D+Z275 according to EN 10346
2. Cold drawn steel top strip
 - a) made of steel of grade S235JRC+C according to EN 10277
 - bold steel
 - hot dip galvanized in HDG options
 - b) made of stainless steel of grade 1.4301 according to EN 10088-3
 - in Stainless options
3. Shear connection (headed studs) of diameter \varnothing 10 mm and length 100 mm
 - a) made of steel S235J2+C450, type SD1 according to EN ISO 13918
 - bold steel
 - hot dip galvanized in HDG options
 - b) made of stainless steel of grade 1.4301, type SD3 according to EN ISO 13918
 - in Stainless options
4. Dowels (Annex 1) made of steel of grade S355J2+N according to EN 10025-2 of types
 - a) TERADOWEL circular in options TJ5 (TDC-5) and TJ6 (TDC-6)
 - b) TERADOWEL rectangular in options TJS6 (TDR-6), TJS8 (TDR-8) and TJS12 (TDR-12)

The TERAJOINT[®] and TERAJOINT[®] Strong free movement joints are shown in Annex 2 and Annex 3 and the supplied types (heights) of TERAJOINT[®] and TERAJOINT[®] Strong free movement joints are summarized in Annex 4.

The dowel is covered by thermoplastic polymer with high density (ABS, HDPS, HDPE) sleeve in what the movement of dowel is ensured. The dowels are metal gas welded and the shear studs are drawn arc welded.

The two steel top strips are connected together with hex head nylon (polyamid) screws according to EN ISO 4017. During shrinkage of concrete the bolts break and the joint intersection becomes discontinuous allowing the movement in both longitudinal and transversal direction of adjacent dilatation units due to drying shrinkage and temperature changes in slab.

The ETA covers also the TERAJOINT[®] X-Junction and TERAJOINT[®] T-Junction accessories used when more concrete slabs intersect, Annex 5.

2 Specification of the intended use(s) in accordance with the applicable European Assessment Document (hereinafter EAD)

The TERAJOINT[®] and TERAJOINT[®] Strong free movement joints are intended to provide continuity in ground supported slabs and transfer the loads through the edges of each panel of the slab to another if required to provide continuity in the slab.

The products are also intended to provide protection to slab edges and ensure slab serviceability of the ground floor slab.

The TERAJOINT® and TERAJOINT® Strong free movement joints are intended to provide a minimum of restraint to horizontal movements caused by drying shrinkage and temperature changes in the slab, while restricting relative vertical movement. There is no reinforcement across the joint. Dowels in free movement joints or other mechanisms provide the load transfer. The load transfer mechanisms including dowels and dowel sleeves shall be engineered to minimise the vertical movement. The product shall be provided between adjoining floor slabs where for example the floor surface is trafficked by material handling equipment.

The assumed working life of TERAJOINT® and TERAJOINT® Strong free movement joints for the intended use is 50 years when installed in the works (provided that the free movement joints are subject to appropriate installation).

These provisions are based upon the current state of the art and the available knowledge and experience. When assessing the product the intended use as foreseen by the manufacturer shall be taken into account. The real working life may be, in normal use conditions, considerably longer without major degradation affecting the basic requirements for works¹.

3 Performance of the product and references to the methods used for its assessment

The performance of the product is summarized in Table 1.

Table 1 – Performance of the assembled system

Product – type: TERAJOINT® and TERAJOINT® Strong		Intended use: The TERAJOINT® and TERAJOINT® Strong free movement joints are intended to provide continuity in ground supported slabs and transfer the loads through the edges of each panel of the slab to another if required to provide continuity in the slab. The products are also intended to provide protection to slab edges and ensure slab serviceability of the ground floor slab. The TERAJOINT® and TERAJOINT® Strong free movement joints are intended to provide a minimum of restraint to horizontal movements caused by drying shrinkage and temperature changes in the slab, while restricting relative vertical movement. There is no reinforcement across the joint. Dowels in free movement joints or other mechanisms provide the load transfer. The load transfer mechanisms including dowels and dowel sleeves shall be engineered to minimise the vertical movement. The product shall be provided between adjoining floor slabs where for example the floor surface is trafficked by material handling equipment.
Basic requirement for construction work (BWR)	Essential characteristic	Performance
1	Load transfer capacity	Annex 5 and Annex 6
	Durability	Annex 6
	Dimensions, tolerances on dimensions and shape, mass	Annex 6
6	Thermal performance	No performance assessed
	Condensation risk	No performance assessed
NOTE 1 BWRs 2, 3, 4, 5 and 7 are not relevant see EAD 200089-00-0302.		

¹ The real working life of a product incorporated in a specific works depends on the environmental conditions to which that works is subject, as well as on the particular conditions of the design, execution, use and maintenance of that works. Therefore, it cannot be excluded that in certain cases the real working life of the product may also be shorter than referred to above.

4 Assessment and verification of constancy of performance (hereinafter AVCP) system applied, with reference to its legal base

4.1 System of assessment and verification of constancy of performance

According to the Decision 98/214/EC amended by Decision 2001/591/EC the European Commission, the system of assessment and verification of constancy of performance system 2+ applies, see Table 2.

Table 2 – System of assessment and verification of constancy of performance applicable to TERAJOINT[®] and TERAJOINT[®] Strong

Product(s)	Intended use(s)	Level(s) or class(es)	System(s) of assessment and verification of constancy of performance
Structural connectors metallic rivets, bolts (nuts and washers) and H. R. bolts (high strength friction grip bolts), studs, screws, railway fasteners	For uses in structural metallic works	Any	2+

The manufacturer shall draw up the declaration of performance and determine the product type on the basis of the assessments and verifications of constancy of performance carried out under the system 2+ as laid down in the Commission Delegated Regulation (EU) No 568/2014 of 18 February 2014, Annex V, 1.3. This system provides for:

- (a) the manufacturer shall carry out:
 - (i) an assessment of the performance of the construction product on the basis of testing (including sampling), calculation, tabulated values or descriptive documentation of that product;
 - (ii) factory production control;
 - (iii) testing of samples taken at the manufacturing plant by the manufacturer in accordance with the prescribed test plan;
- (b) the notified factory production control certification body shall decide on the issuing, restriction, suspension or withdrawal of the certificate of conformity of the factory production control on the basis of the outcome of the following assessments and verifications carried out by that body:
 - (iv) initial inspection of the manufacturing plant and of factory production control;
 - (v) continuing surveillance, assessment and evaluation of factory production control.

4.2 Construction products for which a European Technical Assessment has been issued

Manufacturers undertaking tasks under system 2+ shall consider the European Technical Assessment issued for the construction product in question as the assessment of the performance of that product. Manufacturer shall therefore not undertake the task referred to in point 4.1 (a)(i).

5 Technical details necessary for the implementation of the AVCP system, as provided for in the applicable EAD

Technical details necessary for the implementation of the AVCP system are laid down in the control plan deposited in TSÚS.

Technický a skúšobný ústav stavebný, n. o.
Building Testing and Research Institute
Studená 3, 821 04 Bratislava, Slovak Republic

On behalf of the Technický a skúšobný ústav stavebný, n. o.
Bratislava, 23 June 2020



prof. Ing. Zuzana Sternová, PhD.
Head of Technical Assessment Body

List of annexes

- Annex 1 Components of free movement joints and dimensions of TERADOWELS
- Annex 2 TERAJOINT® free movement joint
- Annex 3 TERAJOINT® Strong free movement joint
- Annex 4 Types of TERAJOINT® free movement joints
- Annex 5 TERAJOINT® Junctions, input parameters of TERADOWELS to calculations of load transfer capacities
- Annex 6 Shear capacity per dowel, bearing/bending capacity per dowel, summary of materials of components/environmental conditions/coating thickness/concrete cover

Components of free movement joints

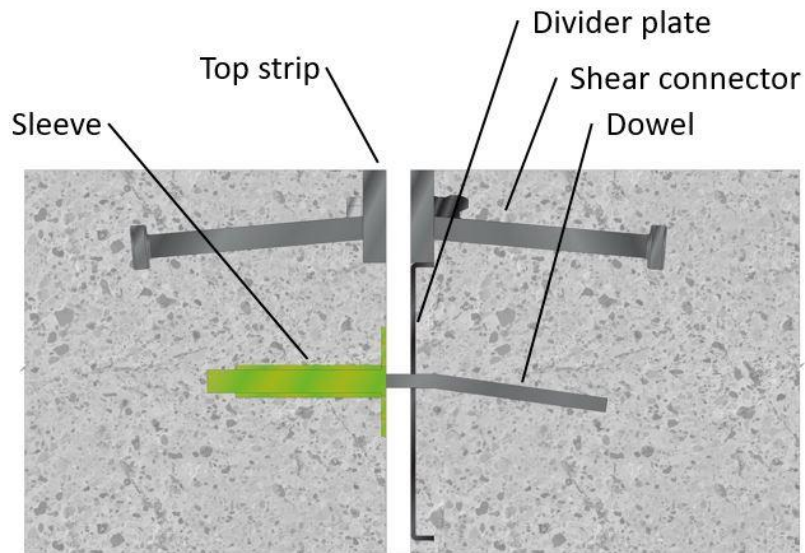

Dimensions of TERADOWELS

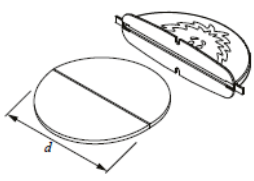
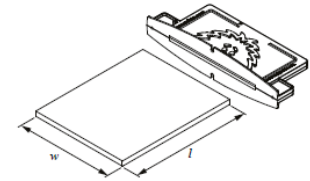
					
Type of dowel	TDC-5	TDC-6	TDR-6	TDR-8	TDR-12
Thickness	5 mm	6 mm	6 mm	8 mm	12 mm
Diameter <i>d</i>	150 mm	150 mm	-	-	-
Dimensions <i>w</i> × <i>l</i>	-	-	150 mm × 135 mm	145 mm × 175 mm	150 mm × 150 mm
Adjustable joint opening	0 to 15 mm	0 to 15 mm	0 to 20 mm	0 to 30 mm	0 to 30 mm

Components of free movement joints and dimensions of TERADOWELS

**Annex 1
of European Technical Assessment
ETA 20/0488**

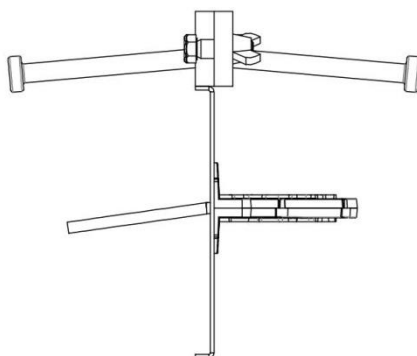

side view

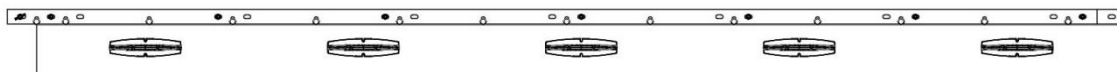

front view

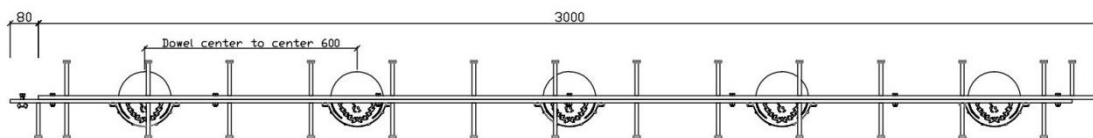

top view

TERAJOINT® free movement joint

Annex 2
of European Technical Assessment
ETA 20/0488

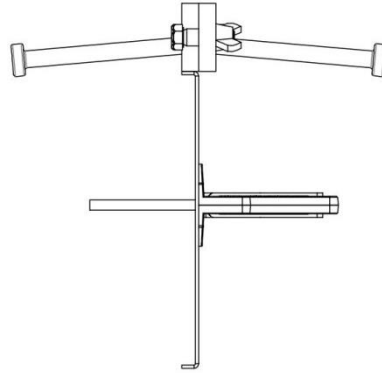

side view

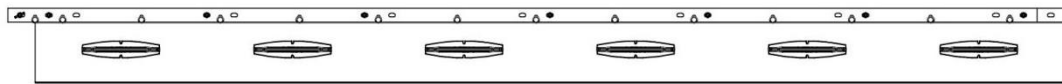

front view

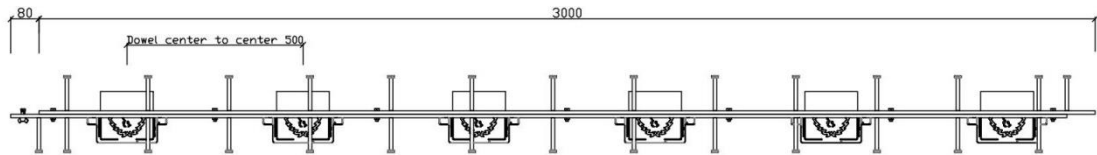

top view

TERAJOINT® Strong free movement joint

Annex 3
of European Technical Assessment
ETA 20/0488

TERAJOINT® TJ5			
TJ5-90-3000	TJ5-115-3000	TJ5-135-3000	TJ5-160-3000
TJ5-90-3000 HDG	TJ5-115-3000 HDG	TJ5-135-3000 HDG	TJ5-160-3000 HDG
TJ5-90-3000 Stainless	TJ5-115-3000 Stainless	TJ5-135-3000 Stainless	TJ5-160-3000 Stainless
TERAJOINT® TJ6			
TJ6-90-3000	TJ6-115-3000	TJ6-135-3000	TJ6-160-3000
TJ6-90-3000 HDG	TJ6-115-3000 HDG	TJ6-135-3000 HDG	TJ6-160-3000 HDG
TJ6-90-3000 Stainless	TJ6-115-3000 Stainless	TJ6-135-3000 Stainless	TJ6-160-3000 Stainless
TJ6-185-3000	TJ6-215-3000	TJ6-230-3000	TJ6-245-3000
TJ6-185-3000 HDG	TJ6-215-3000 HDG	TJ6-230-3000 HDG	TJ6-245-3000 HDG
TJ6-185-3000 Stainless	TJ6-215-3000 Stainless	TJ6-230-3000 Stainless	TJ6-245-3000 Stainless
TERAJOINT® Strong TJS6			
TJS6-90-3000	TJS6-115-3000	TJS6-135-3000	TJS6-160-3000
TJS6-90-3000 HDG	TJS6-115-3000 HDG	TJS6-135-3000 HDG	TJS6-160-3000 HDG
TJS6-90-3000 Stainless	TJS6-115-3000 Stainless	TJS6-135-3000 Stainless	TJS6-160-3000 Stainless
TJS6-185-3000	TJS6-215-3000	TJS6-230-3000	TJS6-245-3000
TJS6-185-3000 HDG	TJS6-215-3000 HDG	TJS6-230-3000 HDG	TJS6-245-3000 HDG
TJS6-185-3000 Stainless	TJS6-215-3000 Stainless	TJS6-230-3000 Stainless	TJS6-245-3000 Stainless
TERAJOINT® Strong TJS8			
TJS8-135-3000	TJS8-160-3000	TJS8-185-3000	TJS8-215-3000
TJS8-135-3000 HDG	TJS8-160-3000 HDG	TJS8-185-3000 HDG	TJS8-215-3000 HDG
TJS8-135-3000 Stainless	TJS8-160-3000 Stainless	TJS8-185-3000 Stainless	TJS8-215-3000 Stainless
TJS8-230-3000	TJS8-245-3000		
TJS8-230-3000 HDG	TJS8-245-3000 HDG		
TJS8-230-3000 Stainless	TJS8-245-3000 Stainless		
TERAJOINT® Strong TJS12			
TJS12-135-3000	TJS12-160-3000	TJS12-185-3000	TJS12-215-3000
TJS12-135-3000 HDG	TJS12-160-3000 HDG	TJS12-185-3000 HDG	TJS12-215-3000 HDG
TJS12-135-3000 Stainless	TJS12-160-3000 Stainless	TJS12-185-3000 Stainless	TJS12-215-3000 Stainless
TJS12-230-3000	TJS12-245-3000		
TJS12-230-3000 HDG	TJS12-245-3000 HDG		
TJS12-230-3000 Stainless	TJS12-245-3000 Stainless		

Types of TERAJOINT® free movement joints

**Annex 4
of European Technical Assessment
ETA 20/0488**

TERAJOINT® Junctions

TERAJOINT® X-Junction				TERAJOINT® T-Junction			
TJX-90	TJX-115	TJX-135	TJX-160	TJT-90	TJT-115	TJT-135	TJT-160
TJX-185	TJX-215	TJX-230	TJX-245	TJT-185	TJT-215	TJT-230	TJT-245

Input parameters of TERADOWELS to calculations of load transfer capacities

		TDC-5	TDC-6	TDR-6	TDR-8	TDR-12
Thickness of dowel plate t_p	(mm)	5	6	6	8	12
Width of dowel w	(mm)	150	150	150*135	145*175	150*150
Width of section at shear point d_d	(mm)	145,1	145,1	150	145	150
Plate width P_b	(mm)	145	145	150	145	150
Half of joint opening width $e/2$	(mm)	7,5	7,5	10	15	15
Steel grade of dowel plate	-	S355 of subgrade J2+N				
Yield strength f_y	(MPa)	355				
Partial safety factor for steel γ_s	-	1,15				
Partial safety factor for concrete γ_c	-	1,50				
Constant k_3	-	3,0				

TERAJOINT® Junctions, input parameters of TERADOWELS to calculations of load transfer capacities

**Annex 5
of European Technical Assessment
ETA 20/0488**

Shear capacity per dowel

Type		TDC-5	TDC-6	TDR-6	TDR-8	TDR-12
P_{sh}	(kN/dowel)	120,9	145,1	150,0	193,4	300,1

Bearing/bending capacity per dowel

Concrete	C20/C25	C25/C30	C28/C35	C30/C37	C32/C40	C35/C45	C40/C50
Type	$P_{max,plate}$ (kN/dowel)						
TDC-5	28,2	29,4	30,0	30,3	30,6	31,0	31,6
TDC-6	37,6	39,5	40,4	40,9	41,4	42,1	43,1
TDR-6	32,7	34,0	34,6	34,9	35,2	35,6	36,2
TDR-8	39,0	40,3	40,9	41,2	41,5	42,0	42,5
TDR-12	77,6	81,6	83,5	84,6	85,7	87,1	89,1

Summary of materials of components/environmental conditions/coating thickness/concrete cover

TERAJOINT® and TERAJOINT® Strong	Top strip + anchor	Divider plate	Dowel	Anchors (headed studs)	Environmental condition	Thickness of coating (HDG)	Concrete cover
Bold steel	S235JRC+C	DX51D+Z275	S355J2+N	S235J2+C450	Dry internal	-	min. 30 mm
HDG	S235JRC+C+HDG	DX51D+Z275	S355J2+N+HDG	S235J2+C450+HDG	Occasionally wet	min.25 µm	Less than 30 mm
Stainless	1.4301	DX51D+Z275	S355J2+N+HDG	1.4301	Wet+aesthetically demanding	-	Not limited

The tolerance on thickness of dowels is $\pm 1,0$ mm. The tolerances on dimensions are according to production drawings.

Shear capacity per dowel, bearing/bending capacity per dowel, summary of materials of components/environmental conditions/coating thickness/concrete cover

**Annex 6
of European Technical Assessment
ETA 20/0488**

REFERENCES

- [1] Technical Manual, TERAJOINT® and TERAJOINT® Strong Free Movement Joints, PEIKKO GROUP 06/2020
- [2] TERAJOINT® Free Movement Joint, Dowel load transfer capacity, PEIKKO GROUP 07/01/2020
- [3] Control Plan for TERAJOINT® Free Movement Joint (Annexes A, B and C), PEIKKO GROUP 03/04/2020

STANDARDS

Regulation (EU) No. 305/2011	of the European Parliament and of the council of 9 March 2011 laying down harmonised conditions for the marketing of construction products and repealing Council Directive 89/106/ECC
EAD 200089-00-0302	In-Situ Concrete Slab Permanent Joint Former, October 2017
EN 10346:2015	Continuously hot-dip coated steel flat products for cold forming. Technical delivery conditions
EN 10277:2018	Bright steel products. Technical delivery conditions
EN 10088-3:2014	Stainless steel. Part 3: Technical delivery conditions for semi-finished products, bars, rods, wire, sections and bright products of corrosion resisting steels for general purposes
EN ISO 13918:2018	Welding. Studs and ceramic ferrules for arc stud welding (ISO 13918:2017)
EN ISO 4017:2014	Fasteners. Hexagon head screws. Product grades A and B (ISO 4017:2014)