

**Fișă identificare role transportoare**

RI = lungimea rolei cu tot cu lagare .....mm  
 Lt = lungime totala = lungime ax .....mm  
 Lte = lungimea debitata a tevii .....mm  
 $\Phi$  Teava = diametrul exterior a tevii .....mm  
 $\Phi$  Ax = diametrul axului .....mm

Lf = lungimea de frezare a axului .....mm  
 Sw = distanta intre planurile de frezare .....mm  
 g = grosimea peretelui tevii .....mm  
 Ls = distanta la canalul de siguranta .....mm

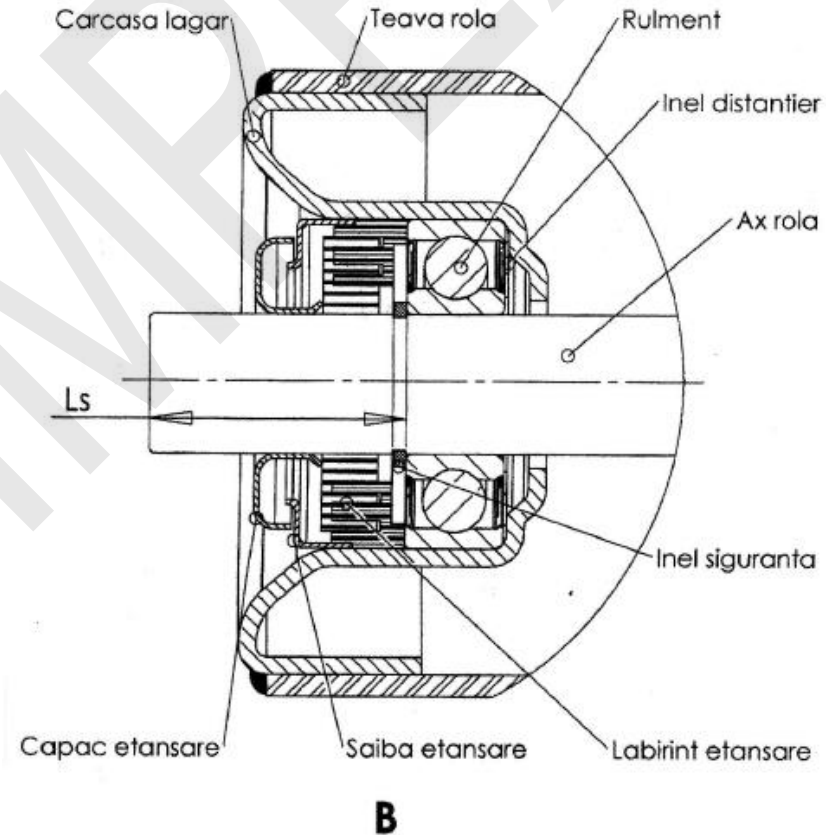
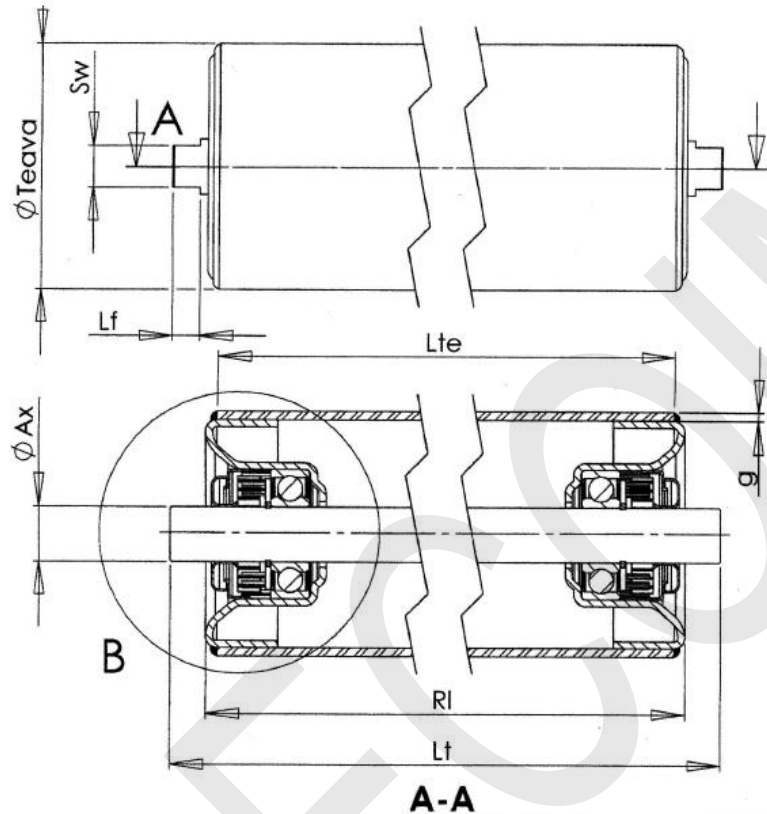

Firma .....  
 Persoana de contact .....  
 E-mail .....  
 Telefon .....  
 Cantitate .....

**Director produs: ing. Demeter Laszlo**

**e-mail: [lanturi@leco.ro](mailto:lanturi@leco.ro)**

**www.leco.ro**