



INNOVATIVE CEILING SYSTEM INFRATOP

VOX

FREEDOM BEGINS AT HOME 4

INFRATOP

YOUR HOME'S EXCELLENT FINISH 7

MANY POSSIBILITIES 8

TECHNOLOGY 11

VENTILATION 12

DESIGN 15

NATURE COLLECTION 16

UNICOLOR COLLECTION 20

INVESTMENT IN THE FUTURE 23

THINKING ABOUT NATURE 24

PRODUCT FEATURES 26

MATERIALS COMPARISON 28

PANELS AND FINISHING PROFILES 30

ASSEMBLY INSTRUCTIONS 32

COMPREHENSIVE SUPPORT 35

OUR REALISATIONS 36

DESIGN INTERIOR IN VOXBOX 38





FREEDOM BEGINS

AT HOME

VOX is an innovative European brand in the interior design and home finishing industry and is a key brand of the VOX Capital Group.

At VOX, we believe that true freedom begins at home and the place we live in makes a huge impact on our lives. That is why our goal is to continuously develop and deliver comprehensive solutions – from matching collections of wall systems, furniture, doors and floors, to the highest quality facade cladding and ceilings.

In 2018, the VOX brand ventured into the Indian Market as VOX BUILDING PRODUCTS PVT LTD and headed by its Director Varun Poddar. VOX's presence in India spans over 250 cities with a strong network of distributors, dealers, and installers. We are committed to the "Make in India" program and plan to start local production in 2023.

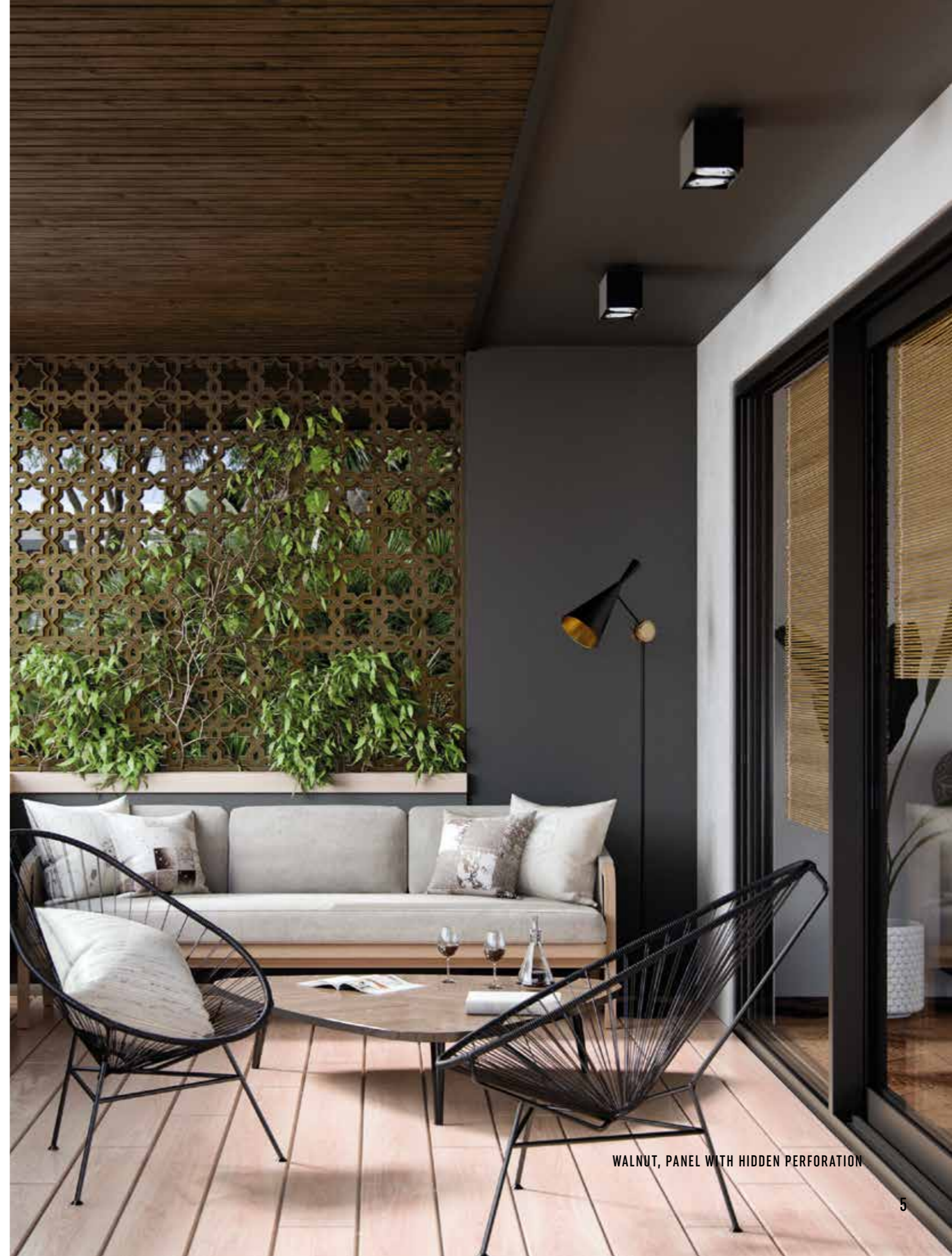

WALNUT, PANEL WITH HIDDEN PERFORATION



DARK MAHOGANY PANEL WITHOUT PERFORATION

YOUR HOME'S EXCELLENT FINISH

The innovative Infratop ceiling system has been designed with both functionality and aesthetics in mind. Thanks to the click system and the increased rigidity of the panels, its installation is quick and easy. The product is lightweight, durable and maintenance-free.

There are two colour ranges to choose from: Unicolor and Nature. Wood-like colours perfectly reflect the grain of the wood and resemble natural wooden boards in shape. Thanks to the use of perforations, we also took care of the proper protection and ventilation of the surface on which Infratop is installed.

Infratop from VOX is a convenient and economical alternative to wooden ceilings.



MANY POSSIBILITIES



Infratop ceilings are a practical and problem-free way to finish roofs, balconies, and terraces. They can also be used in individual houses – in bedrooms, living rooms or bathrooms. It will be perfect both on a large surface and on selected elements of the building or interior. Finishing elements allows you to combine panels in different colours.

FROM INSIDE TO OUTSIDE



The use of the same panels on the ceiling inside the building and on the adjacent terrace will result in a uniform, coherent space.

USE OF LIGHTING



The panels can be fitted with numerous lighting points. Properly selected lighting improves the atmosphere of the place making it unique while the surroundings of the house gain in aesthetics.

UNUSUAL SURFACES

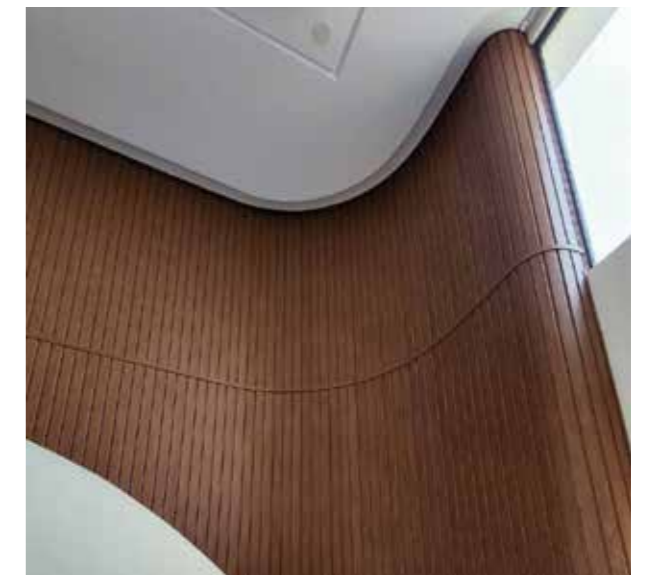

The Infratop system can be used on unusual surfaces. The panels and finishes are flexible, which allows, for example, to finish arches and curved walls.

DESIGN POSSIBILITIES



The product offers many design possibilities. It can be installed horizontally, vertically or diagonally.



TECHNOLOGY

Before being put into production, the products are subjected to numerous tests: market, utility, transport and assembly, so that they meet the growing requirements of customers in the areas of functionality, quality, and design. The laboratory plays the role of research and control of raw materials introduced into production, as well as samples and monitors semifinished and finished products produced on the production lines. We have equipment suitable for testing the physicochemical properties of solid and liquid raw materials, i.e., specific, apparent, bulk density, CIELab colour, flowability and humidity.



KEY USP OF OUR SOFFIT:

Lead & Tin Free

Safety and sustainability converge:
Introducing our lead- and tin-free soffits.

Digital Thermal Print

Precision meets aesthetics and nature's beauty:
Natural wood look and enjoy unparalleled design continuity for up to 100 meters.

Dual Extrusion Layer

Engineered for excellence:
Our dual-layered extrusion ensures superior stability and longevity.

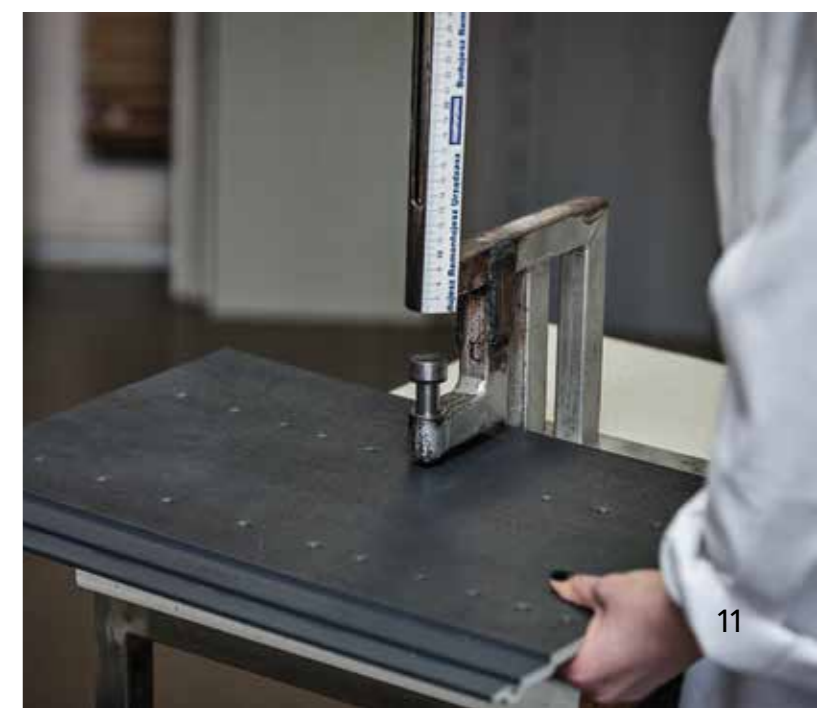
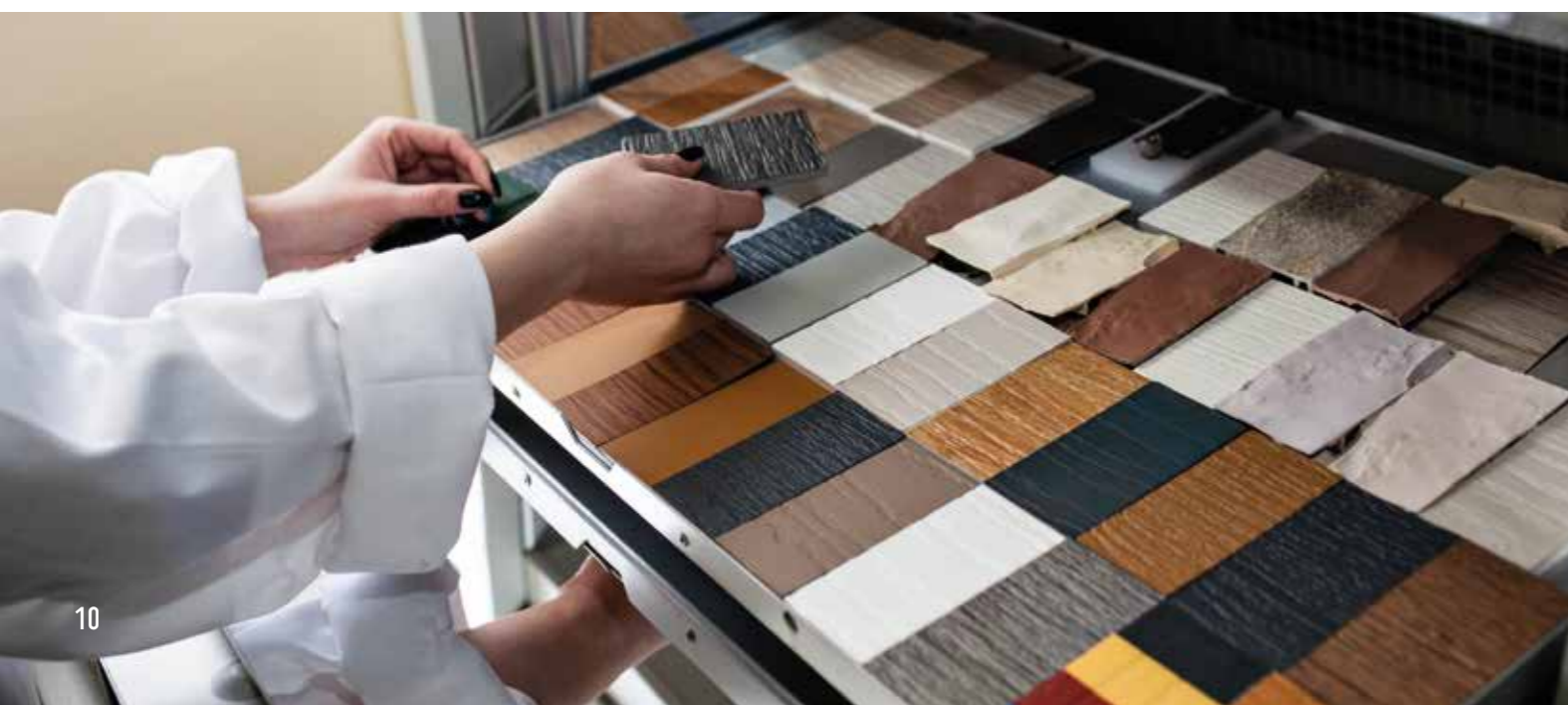

VENTILATION

VOX offers two types of ceilings. The first one is a ceiling with visible perforation on the SV(P)-07 panel, installed in combination with the unperforated SV(P)-08 panel. The second type is the SV(P/PU)-09 ceiling with hidden ventilation. In this case only one type of panel is needed to install it. It is a convenient solution which significantly shortens installation time.

Thanks to the construction with ventilation openings, the ceiling protects the roof against moisture, fungi and mould. Additionally, the shape of the perforation holes provides protection against insects such as wasps, bumblebees and hornets.

Both perforation systems guarantee the best quality and many years of use.

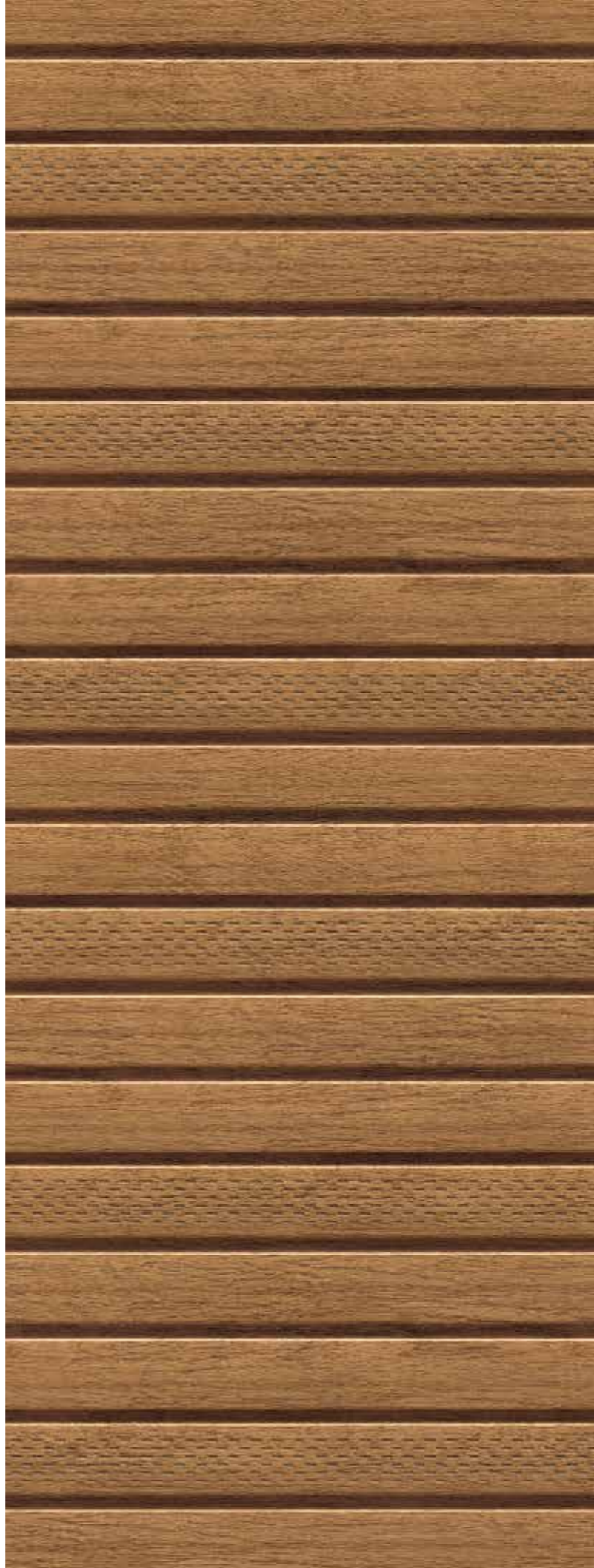

HIDDEN VENTILATION

TYPE SV(P/PU)-09

A patented solution. It is the recess of the panel that is perforated, which produces a better aesthetic result while still ensuring appropriate ventilation of the roof.



VISIBLE VENTILATION

TYPE SV(P)-07

A ceiling with visible perforation on the panel, enabling proper roof ventilation

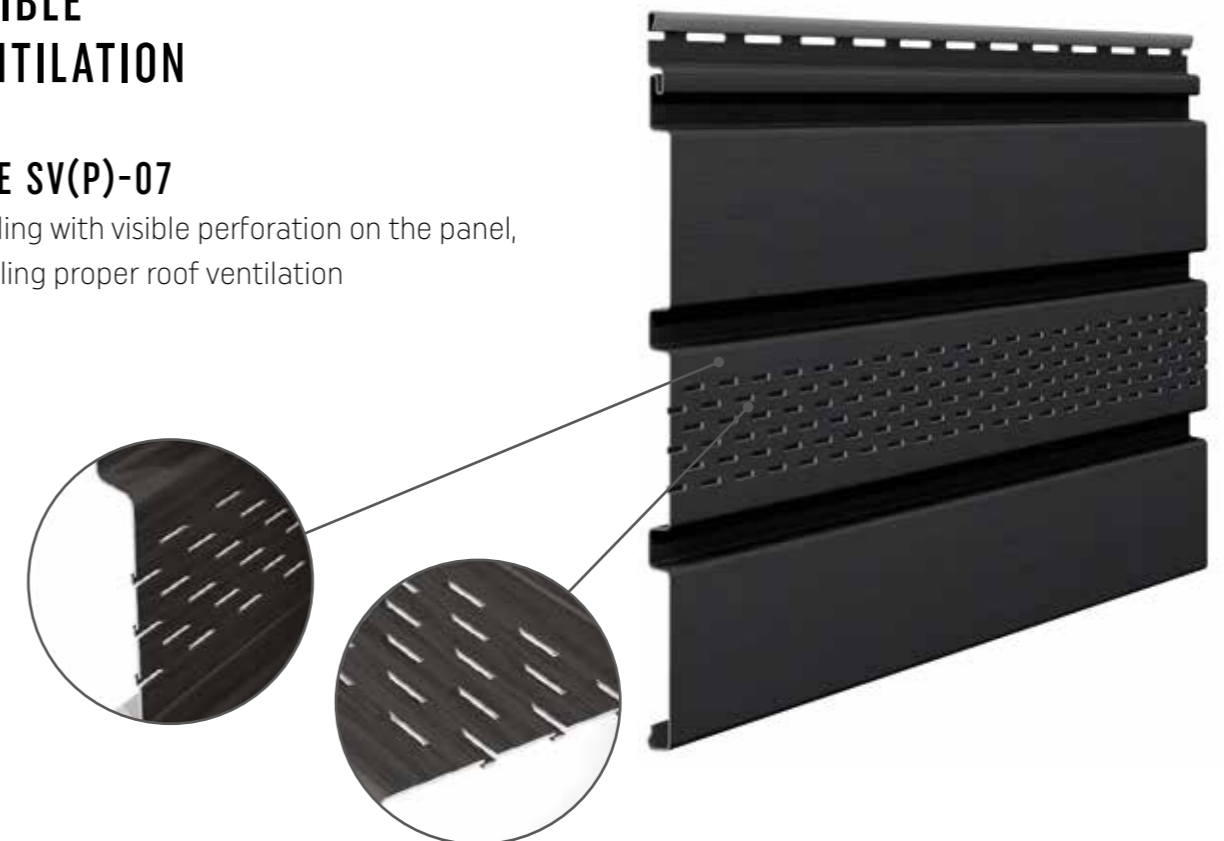

DESIGN



GOLDEN OAK, PANEL WITH HIDDEN PERFORATION

We know that the more talented the people, the greater their ideas. That's why when we work on our collections we invite talented designers to join our creative search. In this way, thoughts and expectations materialize into beautiful and useful products.

We are also constantly working on improving our technologies. That is why when we produced new colours from our Nature collection, we used Thermal Printing, a modern and precise printing technology. Thanks to this, wood-like decors are more similar to natural wood because they have a more interesting and diverse pattern and they can be easily adapted to the wood joinery of your house. In addition, Infratop will allow you to install lighting that will hide cabling and structural elements of the roof.

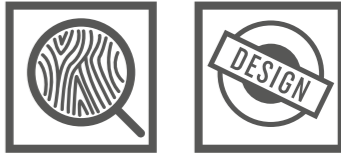

NATURE COLLECTION

NEW IN THE OFFER



DARK MAHOGANY
SVP 08



ROSEWOOD
SVP 08



ROSEWOOD, PANEL WITHOUT PERFORATION

NATURE COLLECTION



WALNUT
SVP 09/08/07



GOLDEN OAK
SVP 09/08/07



OAK
SVP 09/08/07



WINCHESTER OAK
SVPU 09/08/07



WINCHESTER OAK, PANEL WITH HIDDEN PERFORATION

UNICOLOR COLLECTION

NEW IN THE OFFER



WHITE
SV 09/08/07



BROWN
SV 09/08/07



GRAPHITE
SV 09/08/07



BLACK
SV 08



BLACK, PANEL WITHOUT PERFORATION

INVESTMENT IN THE FUTURE



Quick, intuitive installation, easy to clean, resistant to weather conditions and biological corrosion – thanks to these features, you can comfortably and effortlessly enjoy your home's beautiful finish for many years.

Not only does it save you time and money, as it does not require any maintenance, but it also results in lower operating costs. It acts as additional roof insulation which prolongs the life of roof structure elements.

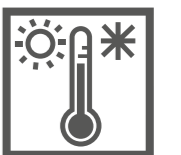

GOLDEN OAK, PANEL WITHOUT PERFORATION

THINKING ABOUT NATURE

Taking care of the environment is our common duty – both on an individual and business level.

When creating the VOX offer, we analyze the production opportunities on an ongoing basis, and we make every effort to ensure that the carbon footprint that we leave in the ecosystem is as low as possible. Modern technological lines, the use of high-quality raw materials, recipes improved over the years and well thought-out design of the products themselves allow to maintain their excellent technical parameters and functionality.

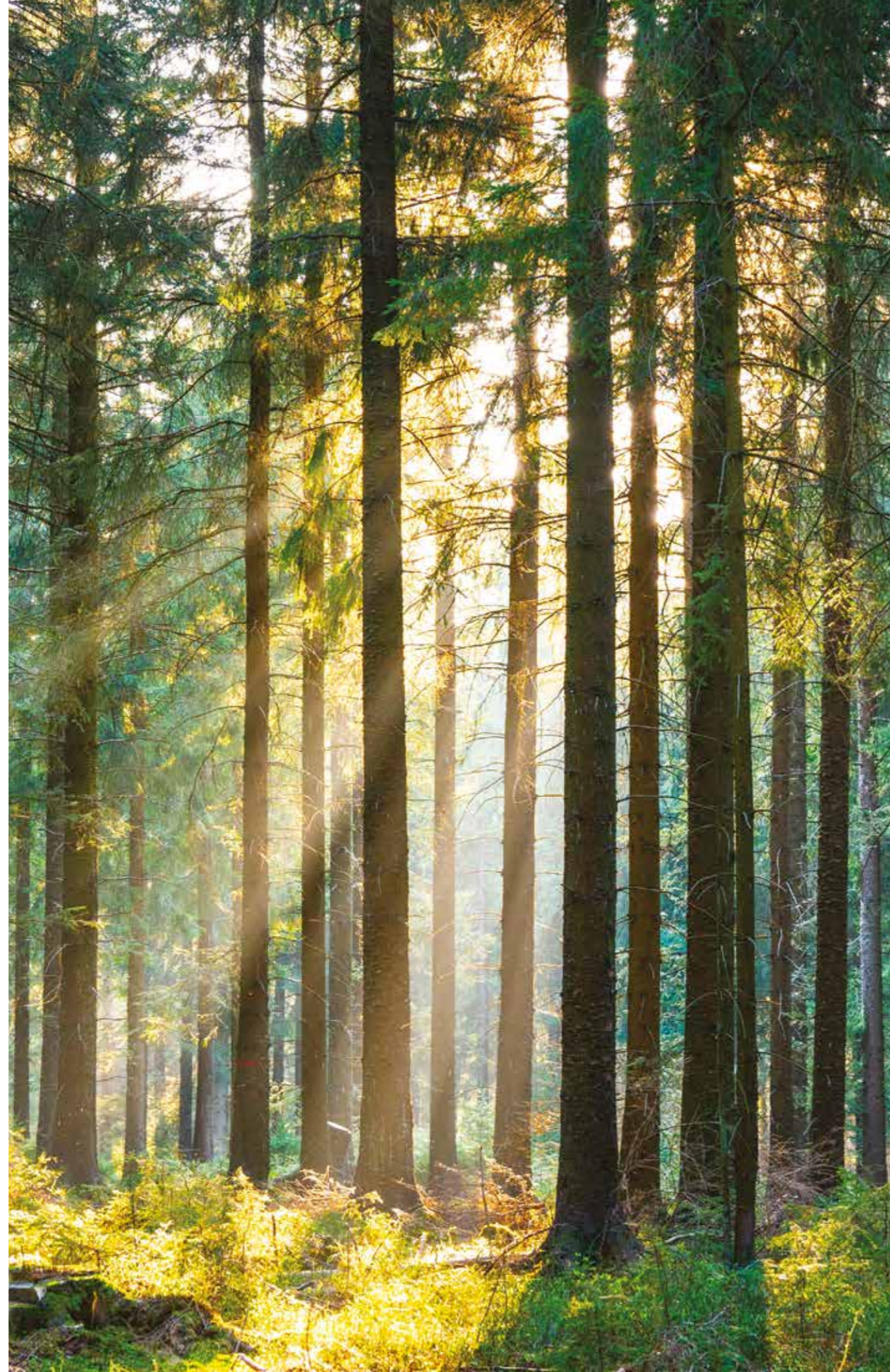

RECYCLING

We use recycled materials in production. Depending on the product, the weight of recyclable materials is up to 80% of the total.



DURABILITY

Our products are extremely durable. The lifetime of many is 10 or even 50 years.



MAINTENANCE

There is no need for maintenance over the entire lifetime, and therefore no additional chemicals (paints, preservatives, etc.)



INSULATION

Soffits ensure proper ventilation of the roof and protect it against moisture.



SAFETY

Harmful substances such as lead and tin are not used in the production process.



HEALTH















Our products are safe for health. They do not contain harmful substances and do not release volatile organic compounds.



CARBON FOOTPRINT

Reduces the carbon footprint of up to 40% compared to products made only of synthetic polymers.

PRODUCT FEATURES

FEATURE	NORM	TEST RESULT	UNIT
 Low weight Facilitates transport and mounting		SV-07/08 – 1,95 SVP-07/08 – 2,20 SV/SVP/SVPU-09 – 2,43	kg/m ²
 Water resistance			
 Termite proof			
 Impact resistance	PN-EN 13245-1:2010	Not less then 3J (-20,03) 5J (23,03)	J
 Self extinguishing properties	PN-EN 13501-1:2019-02	D-s3; d0	class
 Lead and tin free	Art. 33 of Regulation (EC) no. 1907/2006 (REACH)		
 Resistance to changing weather conditions		Max. short-term temp: 70°C Max. temp. in continuous mode: 60°C Min. application temp: - 30°C	
 Quick installation Wide covering width, built-in locks and factory made nail slots facilitate and speed up the installation			
 Click System Thanks to it, the assembly is easy and fast			
 Maintenance free No need for painting and other treatment			
 Easy to keep clean Can be clean with water and mild detergents			
 Recycled product 100% recyclable			
 10 years product warranty			
 A+ No emissions of harmful substances	PN-EN 16516+A1:2020-12 PN-EN ISO 16000-9:2009 ISO 16000-6:2021, ISO 16000-3:2022	A+	grade



WALNUT, PANEL WITHOUT PERFORATION

MATERIALS COMPARISON

	INFRATOP	WOODEN CEILINGS
PRODUCT PRICE INSTALLATION COST	Affordable.	The most expensive.
INSTALLATION		
PRDDUCT WEIGHT	Light panels facilitate transport and installation. No load on the building structure.	Material is much heavier, and more difficult to handle.
INSTALLATION TIME	Quick and easy installation. Ready to use panels, no additional work required after installation.	Extended and Longer time for Installation. Need polishing.
INSTALLATION METHOD	Built-in CLICK lock and factory-made screw holes facilitate faster installation. No dust during installation.	No interlock and mounting holes. Lot of dust during installation.
TO UNINSTALL AND REPAIR	Easy to uninstall, just unscrew to remove the panels and refix again. Panels can be removed and reused at other place.	Very difficult to uninstall.
FEATURES		
APPEARANCE AND TEXTURE	Pattern reflects the natural texture of the wood, which gives wood alike feel and natural effect. Textures repeat after every 100 running meters.	Requires impregnation to achieve required wood colour and also to repeat impregnation on regular intervals to maintain the colour and the finish.
WEATHER RESISTANCE	Shape of the panels provide guarantee for their rigidity, the panels do not flutter in the wind. Thermal printing technology is used for decor and textures, same is tested for different weather conditions.	Resistance is achieved only after applying appropriate impregnant. Impregnation should be repeated on regular intervals.
IMPACT RESISTANT	Resistant to the mechanical damage.	Susceptibility to mechanical damage and distortion.
FADE RESISTANT	Panels can be installed under the roof both inside and outside the building.	Resistance depends on the type and quality of the impregnates used.
RESISTANCE TO BIOLOGICAL FACTORS: (PESTS, MOLD)	It provides no sustenance for insects, termites and fungi.	It is exposed to biological corrosion, so the wood before laying should be dried and antifungal impregnated.
MAINTAINENCE	Maintenance free.	Need regular maintenance.
WATERPROOF	100% Waterproof.	Susceptibility to the action of water and moisture.
FIRE RESISTANT	Self extinguishing properties.	Depends on the type of treatment done to the wood.
VENTILATION	Panel comes with ventilation holes and provide proper ventilation to the roof. SV09 panels ventilation is patented.	Depends on usage and pattern of installation.
WARRANTY	10 years in India.	No warranty.

HPL CEILINGS	GYPSUM CEILINGS	METAL CEILINGS
Expensive.	Low cost.	Affordable.
INSTALLATION		
Material is heavier, and more difficult to handle, resulting in the lengthy installation.	Material is much bigger and slightly heavier. Possibility of cracks during handling.	Material is much heavier, and more difficult to handle, resulting in the lengthy installation.
Time-consuming installation.	Quick installation due to the large covering surface. Need finish using putty and paint.	Time-consuming installation.
No interlock and mounting holes. No much dust during installation.	No interlock and mounting holes. Lot of dust during installation.	No interlock and mounting holes. No dust during installation.
Easy to uninstall.	Tedious uninstallation process. Repairs will involve breaking the whole board down.	Difficult to uninstall.
FEATURES		
High-pressure laminates tend to have a smooth and even surface finish with repeat of textures in every board.	Just plain panels no texture available. Need to paint to get desired texture and colour.	Glossy or matt colour achieved by painting or powder coating the panel.
Resistance to weather conditions.	Doesn't withstand all weather conditions.	The material is highly resistant to large temperature differences, but without adequate protection corrodes easily.
Resistance to mechanical damage.	Susceptibility to mechanical damage and distortion.	Resistance to mechanical damage.
Resistance to fade.	Intense colours quickly fade and also changes colour under the influence of dirt and foreign particles.	Resistance to fading depends on the paint used.
Resistance to biological factor.	Due to moisture, fungus can develop.	It provides no sustenance for insects and fungi.
Low maintenance.	Need maintenance.	Need maintenance.
Waterproof.	Susceptibility to the action of water and moisture.	Easily corrodes and becomes rusty.
Fire retardant.	Fire retardant.	Fire retardant.
No ventilation holes in the panels.	No ventilation holes in the panels, need to provide ventilation grills.	No ventilation holes in the panels, need to provide ventilation grills.
Comes with warranty.	No warranty.	Comes with warranty.

PANELS AND FINISHING PROFILES

SV(P)-07

Panel with visible perforation



* Mounted with SV(P)-08

SV(P/PU)-09

Panel with hidden perforation



* Self-assembled

SV(P)-08

Panel without perforation



* Mounted with SV(P)-07

SV(P/PU)-15

J profile



SV(P/PU)-18

Connector

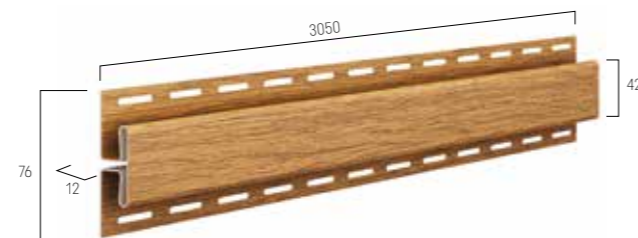

The panels are available in two lengths depending on the colour and shape.

COLOUR	PANEL SHAPE	AVAILABLE LENGTH	
		2700 mm	3850 mm
BROWN	SV 08	✓	
	SV 07	✓	
	SV 09	✓	
GRAPHITE	SV 08	✓	
	SV 07	✓	
	SV 09	✓	
WHITE	SV 08	✓	
	SV 07	✓	
	SV 09	✓	
BLACK	SV 08	✓	✓
DARK MAHOGANY	SVPU 08	✓	✓
ROSEWOOD	SVP 08	✓	✓
GOLDEN OAK	SVP 08	✓	✓
	SVP 07	✓	
	SVP 09	✓	
WALNUT	SVP 08	✓	✓
	SVP 07	✓	
	SVP 09	✓	
WINCHESTER OAK	SVPU 08	✓	✓
	SVPU 07	✓	
	SVPU 09	✓	
OAK	SVP 08	✓	
	SVP 07	✓	
	SVP 09	✓	



WALNUT, PANEL WITHOUT PERFORATION

ASSEMBLY INSTRUCTIONS

1.

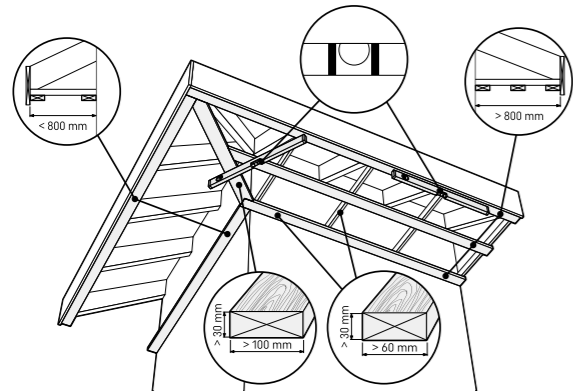

2.

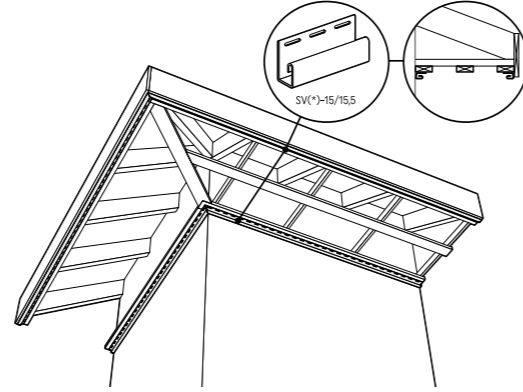

7.

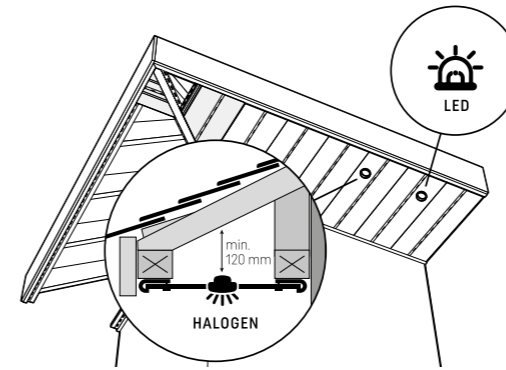

3.

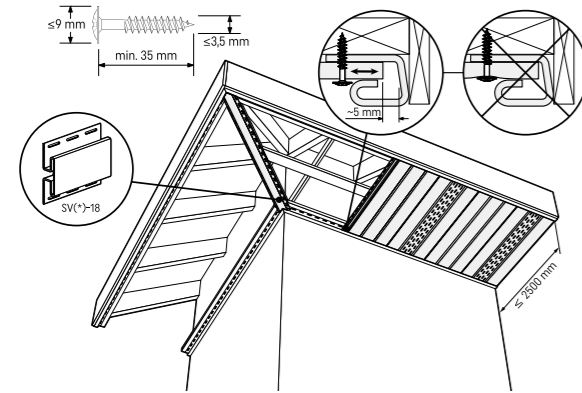

4.

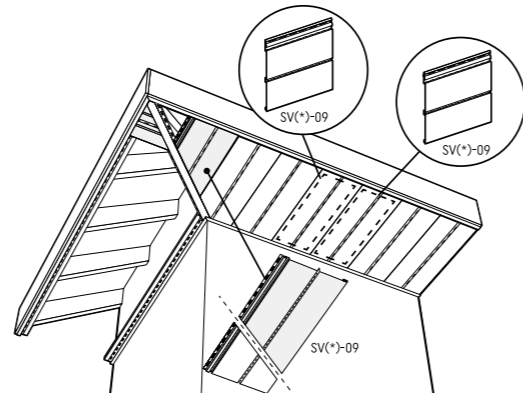

8.

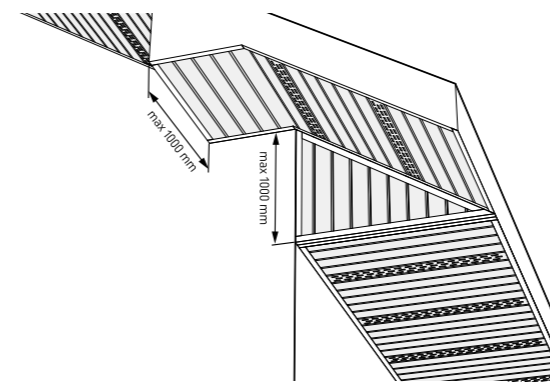

5.

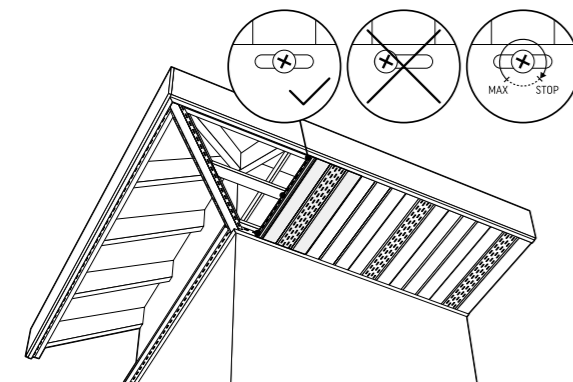

6.

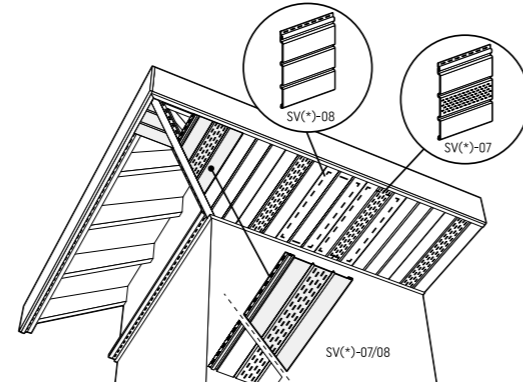

SV(*)=SV(P/PU)



WALNUT, PANEL WITH HIDDEN PERFORATION



OAK, PANEL WITHOUT PERFORATION

COMPREHENSIVE SUPPORT

At VOX, we offer support at every stage of the project. From professional design assistance to reliable installation assistance.

DESIGN SUPPORT:

1. Conceptualizing into rendering drawing.
2. Options for design selection.
3. Material calculation and quantifying.



TECHNICAL SUPPORT:

1. Installation training and monitoring.
2. Site survey and measurements.
3. Grievance solutions.



OUR REALISATIONS



Many customers have already trusted us, thanks to which we were able to implement interesting projects. The Infratop soffit has proven itself perfectly and looks great both on smaller single-family houses as well as on large development and public investments.

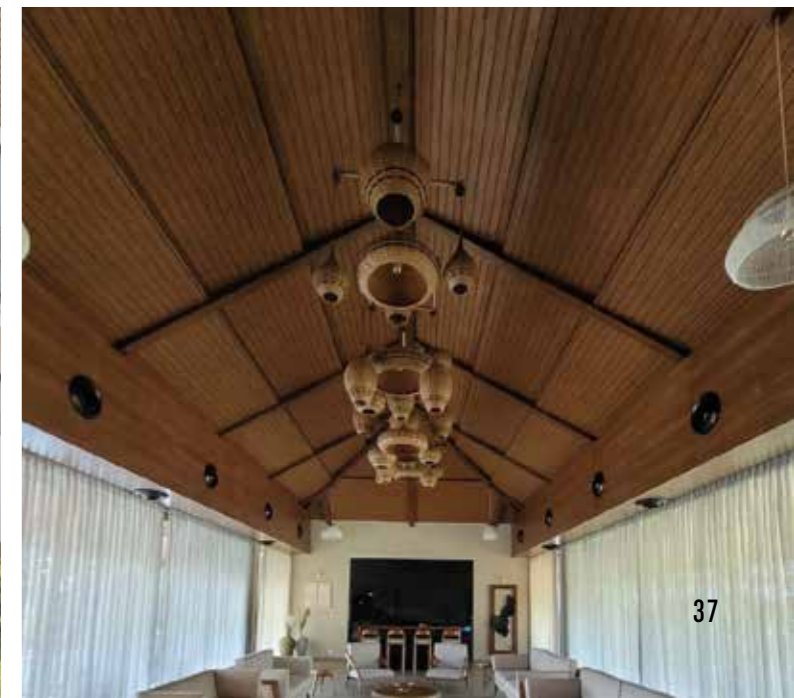

DESIGN INTERIOR IN VOXBOX

VOXBOX is an intuitive program for interior design. It is available online and requires no additional software installation. Thanks to VOXBOX, you can create realistic room visualizations in a few moments and test various solutions that will allow you to arrange any space. You can make projects from a scratch or use our pre-made projects, each of which can be modified as desired.



In 2020, the VOXBOX program was awarded with the title of laureate in the Good Design competition – one of the most important awards in the interior and design industry in Poland. In the justification, the jury noted the practicality and usefulness of the application, which helps to design your dream interiors directly in the web browser. They also appreciated the program's interface, which is friendly even to an inexperienced user.

PROJECTS CAN ALSO BE VIEWED IN VR TECHNOLOGY
IN SELECTED VOX SHOWROOMS

LOOKING FOR INSPIRATIONS?

It is possible to use our database of ready-made projects. All you have to do is modify the dimensions of the spaces we propose so that they are identical with your interior and it's ready.

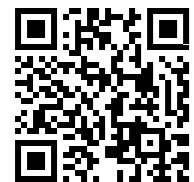

Scan QR
code to open
VOXBOX app



The manufacturer reserves the right to change the colours, dimensions, and functions of the presented products. This catalogue is published for informational purposes only. The catalogue presents examples of patterns from the offer. Some items presented in the arrangement, photos are for decoration only and are not for sale. Copying and distribution of any materials contained in the catalogue without the written consent of the publisher is prohibited. The colours in the catalogue may differ from reality. All data contained in the catalogue are valid in the month when the catalogue is submitted for printing – August 2023.

VOX BUILDING PRODUCTS PRIVATE LIMITED
6th Floor, Leela Collonnade, The Leela Palace, No. 23, HAL Old Airport Rd,
HAL 2nd Stage, Kodihalli, Bengaluru - 560008, India
Ph No: 0952850050 / +91 8043741810
WA No: 6366843663
E: customercare@voxindia.co

voxindia.co

