

orlański



natural warmth of the house

INSTRUCTION MANUAL & SERVICE MANUAL ORLIGNO 500



MANUAL INSTRUCTION

CONTENTS

1. Boiler application	3
2. Description of the controller	3
2.1. Lightning up	5
3. Controller's menu description	6
3.1. Menu handling	6
3.2. Alarm status and safety devices	11
4. Feed system	12
4.1. Feed system-alarm status	12
4.2. Feed system protection	12
5. Maintenance	13

1. Boiler application

Low temperature pellet boiler Orligno 500 produced by Eko-Vimar Orłański Ltd. is adapted for central heating installations also for hot utility water heating.

Main fuel use in ORLIGNO 500 is pellet with 6-8 mm diameter and length 10-50 mm.

Capacious pellet hopper lets for very long boiler operation without need to refill the hopper.

Boiler is adapted for installation in open or pressurized system with pressure vessel allowing to work with working pressure.

2. Description of the controller

Boiler controller is a modern microprocessor system which controls not only the boiler but also central heating system and hot domestic water.

Device controls quantity of feed fuel through periodic operation of feeder's engine and amount of supplied air for burning process. Thanks to semiconductor transmitters power of the blower is fluently adjusted thus increasing reliability of control system of feeder's engine.

Automatic burning up. Controller enables automatic burning up of the fuel on the burner.

Measurement of fumes temperature. Controller enables reading fumes temperature, it is necessary for boiler operation with automatic igniting . Measurement of fumes temperature is important for control and boiler adjustment.

Thanks to advanced algorithm and possibility to adjust many parameters; system can be easily adapted to the heating system needs.

Controller is equipped with **output test function** that enables to check correct electric connections and executive devices (pump, blower, feeder, mixing valve's actuator) before boiler is put into action.

Alphanumeric display makes easier to communicate between user and controller, easy handling.

New intuitive controller's menu with 6 languages at choice: polish, english, german, french, lithuanian and russian.

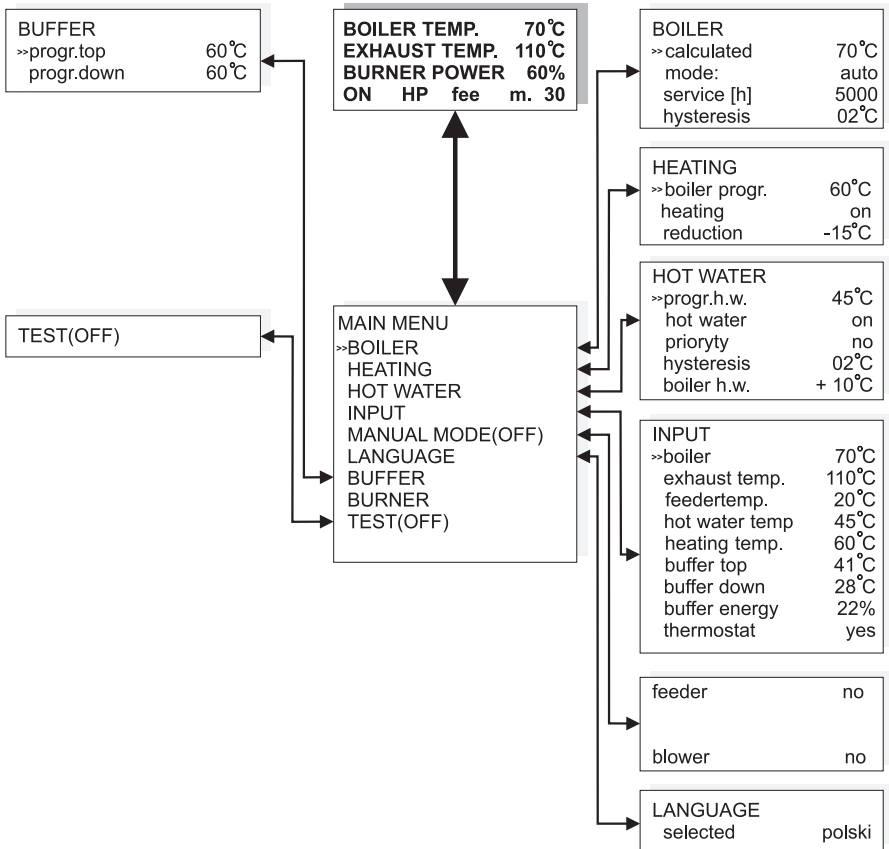

Pic. 1. Controller's menu.

2.1. Burning up

1. Pour the pellets into the hopper and tightly close the lid.
2. Connect the main power plug into the 230V/50 socket.



ATTENTION!

Socket should be protected with min. 10A fuse and 20 mA RCD (residual current device).

3. Start the controller.

To start the controller it is necessary to press the „ON/OFF/ESC” button for 3 seconds. The same operation with turning off the controller. Present status is shown on the display:

OFF – (active control of alarm parameters, manual mode of blower and feeder)

ON



ATTENTION!

When „OFF” is shown on the display device is in standby mode and is still live. In case of alarm controller will activate all pumps or feeders.



ATTENTION!

It is forbidden to use for boiler lightning up any flammable substances.

If boiler is in idle time or maintenance is made it's essential to unplug the boiler from the main power.

Display shows current state of individual devices. Picture shows main menu view.

BOILER TEMP. 70°C
EXHAUST TEMP. 110°C
BURNER POWER 60%
ON HP fee m. 30

Pic. 2. Main display.

Last line on display shows through abbreviations active devices.

ABBR.	DESCRIPTION
HP	central heating pump operation
WP	hot water pump operation
BU	buffer pump operation
LIG	heating element operation
fee	feeder operation
fa 20	blower operation, current blower output
M0	mixing valve closing
M1	mixing valve opening

Tab 1. Abbreviation table with devices names.

After pouring the pellets it is recommended to manually start the feeder in order to transport fuel to the burner.

Go to menu MANUAL MODE, which is displayed below:

feeder	no
blower	no

Rys 3. Manual mode.

To turn on/off the feeder press .

To turn on/off the blower press .

Feeders should work until filling the burner with fuel. Next switch the controller in ON mode, fuel will be automatically light up.

3. Controller's menu description

3.1. Menu handling

Controller has two types of menus: SIMPLE MENU and ADVANCED MENU.



ATTENTION !

To change type of menu: SIMPLE or ADVANCED press at the same time  i  buttons. After 10 minutes of inaction from user menu will automatically be changed on SIMPLE.





ATTENTION !

Instruction manual contains all control parameters available both in SIMPLE or ADVANCED menu. Parameters from ADVANCED menu are written in italics.

To go in to the main menu press „ENTER” button.

-main menu, written with capital letters, buttons  and  are for move within main menu, to go in to submenu press „ENTER”. To go out from submenu press „ESC”. Main menu is shown on pic.1

-submenu is for displaying and changing operation parameters. In order to change the parameter press „ENTER”. Changing parameter will be displayed periodically. Changing parameter on different one press  or . To withdraw from changed parameter press „ESC”. To accept the changes press „ENTER” .

Cale menu zostało przedstawione pkt. 2. Opis regulatora.

MAIN MENU
>>BOILER
HEATING
HOT WATER
INPUT
MANUAL MODE(OFF)
LANGUAGE
BUFFER
BURNER
TEST(OFF)

Pic. 1. Main Menu

Menu Boiler

Boiler can operate in one of two operation modes: manual and auto.

BOILER	
>> calculated	70°C
mode:	auto
service [h]	5000
hysteresis	02°C

Pic. Menu BOILER



ATTENTION !

Operation modes decide only about setting method of the boiler temperature.

PARAMETERS

Auto mode – recommended mode. Boiler's temperature is automatically set depending on heat demand.

Manual mode – Boiler's temperature is set by user.

Service – parameter informing about next boiler maintenance.

Hysteresis (only in ADVANCED menu) – parameter deciding about required difference between actual boiler's temperature and set one to start the burner.

Menu heating

Menu for central heating settings. Menu HEATING is shown on picture.

HEATING	
>>boiler progr.	60°C
heating	on
reduction	-15°C

Pic. Menu HEATING CIRCUIT

PARAMETERS

Progr. – kept temperature in heating circuit (radiators, underfloor heating) during demand from room thermostat.

Heating – parameter for turning off/on heating.

Reduction (only in ADVANCED menu) – parameter for adjusting the temperature value .



ATTENTION!

In case if mixing valve with actuator is not installed in central heating circuit, parameters „progr” and „reduction” are turned off.



ATTENTION!

In case if mixing valve with actuator is not installed in central heating circuit, during the first start of the boiler, parameter „mixer” need to be changed on „no” in SERVICE menu.

Menu hot water

Pellet boiler is perfectly matched for hot water heating both during the heating season and summer season. Menu HOT WATER is shown below:

HOT WATER	
>>progr.h.w.	45°C
hot water	on
priority	no
hysteresis	02°C
boiler h.w.	+ 10°C

Pic.7 Menu HOT WATER.

PROGR. H.W. (PROGRAMMED HOT WATER)

Hot water tank need to be equipped with temperature sensor.

PARAMETERS:

Programmable hot water temperature (progr. h.w.) – hot water temperature kept in the tank.

Hot water – parameter for turning on/off hot water function.

Priority (only in ADVANCED menu) – with priority parameter “on” during hot water heating rest of the pumps in the installation are off in order to faster heat the water.

Hysteresis (only in ADVANCED menu) – temperature value that need to decrease temperature of hot water to start heating hot water and temp. value that need to increase to turn off hot water heating.

Boiler h.w. + (only in ADVANCED menu) – temperature value that need to increase to programmed temperature during hot water heating. i.e. if programmed temp of hot water = 60°C and “boiler h.w.+” = 10 °C then programmed temperature during heating hot water is 70°C.

ADVANCED PRIORITY OF HOT WATER

Controller can operate in two modes of hot water heating (known only in gas and oil boilers): hot water priority (recommended) and without priority. During boiler operation with priority mode with hot water heating, works only hot water pump reaching set temp. much faster.

In order to avoid temperature drop in the house during hot water heating and the pump works longer than 20 minutes (pre-set) and programmed temperature of hot water is not reached; central heating pump will start working on 5 minutes.

Parameters available in service menu: „ stop central heating pump with hot water pump” (stop HP/HWP) and „ work central heating pump with hot water pump ”(work HP/HWP).

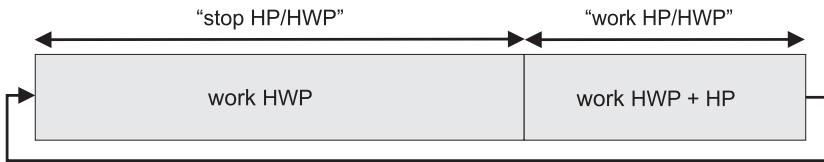

Pic.8 Pump operation during hot water heating in priority mode

Input menu

Input menu shows temperatures from all connected sensors to the controller . Input menu view is shown below:

INPUT	
>>boiler	70°C
exhaust temp.	110°C
feedertemp.	20°C
hot water temp	45°C
heating temp.	60°C
buffer top	41°C
buffer down	28°C
buffer energy	22%
thermostat	yes

Pic. 9 Input menu.

Buffer menu

Menu for adjustment of buffer parameters. Buffer menu view is shown below:

BUFFER	
>>progr.top	60°C
progr.down	60°C

Pic.:Buffer menu

PARAMETERS

Programmed top – programmable temperature in the upper part of the buffer.

Programmed down – programmable temperature in the upper part of the buffer.

OPERATION DESCRIPTION

Buffer pump will be on, when temperature in upper part of the buffer drops below programmed temperature.

Buffer charging lasts until both programmed temperatures are reached.



ATTENTION

Buffer menu is only available in ADVANCED menu..

PARAMETERS

Burner power – available in two modes: auto (recommended) and manual. In auto mode: controller selects burner power accordingly to energy demand of the house.

Programmed power – in auto mode is displayed actual power of the burner , in manual mode burner power can be set as a constant.



ATTENTION!

Burner menu is only available in ADVANCED menu.

Language menu

Controller is equipped with multilingual menu: polish, english, german, french, lithuanian and russian.

Language selection is made in Language menu.

3.2. Alarm status and safety devices

Alarm status is indicated with blinking backlight on the controller's display. After pressing „ENTER“, type of alarm is displayed. Types of alarms:

-boiler overheating;

Alarm is indicated after exceeding 97°C (pre-set) on the boiler. Controller will activate all connected pumps until temperature will decrease.



ATTENTION!

With temperature 2°C lower than alarm temperature, pumps are activated in a initial alarm mode. If temperature do not exceed alarm temperature it will not be remembered in controller's memory.

-no fuel/fire;

Alarm is activated in case of lack of fuel or fire in the burner.

-feeder overheating;

Alarm is activated when permissible feeder's temperature is exceeded.



ATTENTION!

After noticing alarm status, it is recommended to determine cause and remove it.

-thermal boiler protection independent from boiler's controller In case of exceeding boiler's temperature of 94°C thermal boiler protection will turn off blower.



ATTENTION!

After alarm occurred it is recommended to determine cause of alarm, remove it and manually unblock thermostat.

4. Feed system

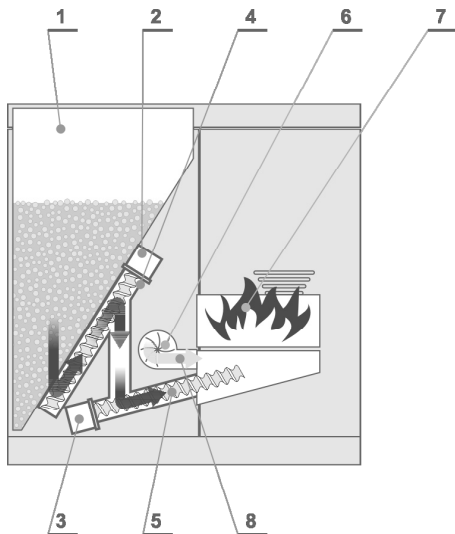

1. Pellet container
2. Motoreductor of a feeder no 1
3. Motoreductor of a feeder no 2
4. Feeder no 1
5. Feeder no 2
6. Fan
7. Burner
8. Heater

Pic. 11. Feed system section

4.1. Feed system –alarm status

In case of exceeding 60°C in the feed system, alarm is activated with blinking display „feeder overheating“.



ATTENTION!

After alarm occurred it is recommended to determine cause of alarm and remove it.

4.2. Feed system protection

Feed system is designed in such a way that flame from burner is not able to get to the pellet hopper. Safe feeding is assured by system of two feeders jointed together with flexible, vertical chute. Fuel feeding is continually monitored by boiler's controller.

Proper feeders cooperation guarantees that vertical chute is always empty – it is a burn-back protection.

5. Maintenance.

Ash created during pellet burning is deposited in the bottom chamber. Bottom chamber needs to be cleaned once a month with tools: scraper, cleaning shield. It is advisable to clean heat exchanger at least once a month to assert permeability of pipes.

If fumes temperature exceeds max. value which will be displayed it is necessary to clean heat exchanger pipes and boiler.

Once a week burner need to be checked thoroughly because of possibility of depositing unburned parts of pellets (especially when pellet quality is bad) which may block pellet feeding and cause uncontrolled burning.



Attention!

If improper pellet issue will repeat it is necessary to fully open blower's screen.

In order to clean heat exchanger:

1. Open upper door
2. Unscrew two nuts with M13 wrench (they secure heat exchanger's plate behind which horizontal pipes are placed).
3. Remove turbulators and clean pipes with shield and turbulators with brush.
4. Place turbulators back into the heat exchanger.



Attention!

If improper pellet issue will repeat it is necessary to fully open blower's screen.

Steps for door correct regulation:

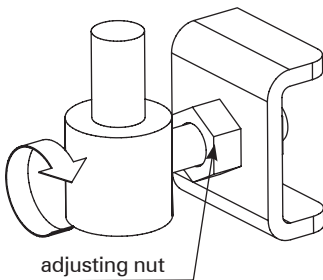

- a) disassembly the door
- b) loosen the adjusting nut
- c) turn the hinge at 360°
- d) tighten up an adjusting nut.



Warning!

Regulation should be made on both upper and bottom hinges at the same time. All threaded door parts should be greased periodically (for exemple with a grease or an oil) as well as hinges.

SERVICE MANUAL

CONTENTS

1. Installation	15
2. Recommended controller's settings	16
3. Block diagram	16
4. Technical data	17
4.1. Dimensions	17
4.2. Boiler technical data	17
4.3. Controller's technical data	18
4.4. Electric data of gear-motors	19
4.5. Mechanical data of gear-motors	19
4.6. Heater's technical data	19
5. Boiler's electric scheme	20
6. Boiler connection	22
6.1. Connection scheme	22
6.2. Hydraulic connections	23
6.3. Cooling coil	23
7. Boiler tightness	24
8. Ventilation	24
8.1. Supply air ventilation	24
8.2. Exhaust ventilation	24
9. Chimney connection	24
10. Troubleshooting	25
11. Ending	26

1. Installation

Boilers should be installed according to binding rules and norms. The requirements of norm PN 87/B 02411 according building of solid fuel boiler room and the norm PN 91/B 02413 according open system boilers' production should be taken into account.

These norms and rules should be followed, however, caution is required as national rules in countries to which the product is sold may replace above mentioned norms.

In case of boiler assembly outside Poland, rules and norms should be followed according to solid fuel boiler assembly in countries in which the boiler is sold. Boiler ORLIGNO 500 is adjusted for installation in pressurized systems.

Eko-Vimar Orlanski Ltd. recommends to use stainless steel flue liners that protect the chimney from damaging effect of wood tar.

Company Eko-Vimar Orlanski does not take responsibility for not complying to above recommendation and damage resulting from it.

During boiler transport, boiler flue may be disassembled by unscrewing nuts (8xM8) and detaching flue from the flange.

At the bottom chamber wrapped in a foil are ceramic moulders which need to be placed on the burner as shown on below picture.

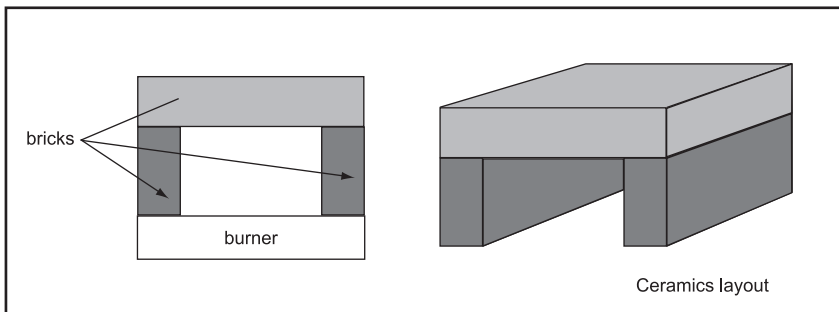

Pic 2. Ceramics layout on the burner

2. Recommended controller's settings

Lp.	Description	Programmed parameter
1.	Boiler operation	Auto mode
2.	Heating temperature	60°C
3.	Underfloor heating temperature max	45°C
4.	Thermostat	-15°C
5.	Hot water temperature	45°C
6.	Priority	yes
7.	Hysteresis	2°C
8.	Boiler h.w.	+10°C
9.	Buffer upper temperature	60°C
10.	Buffer down temperature	80°C

3. Block diagram

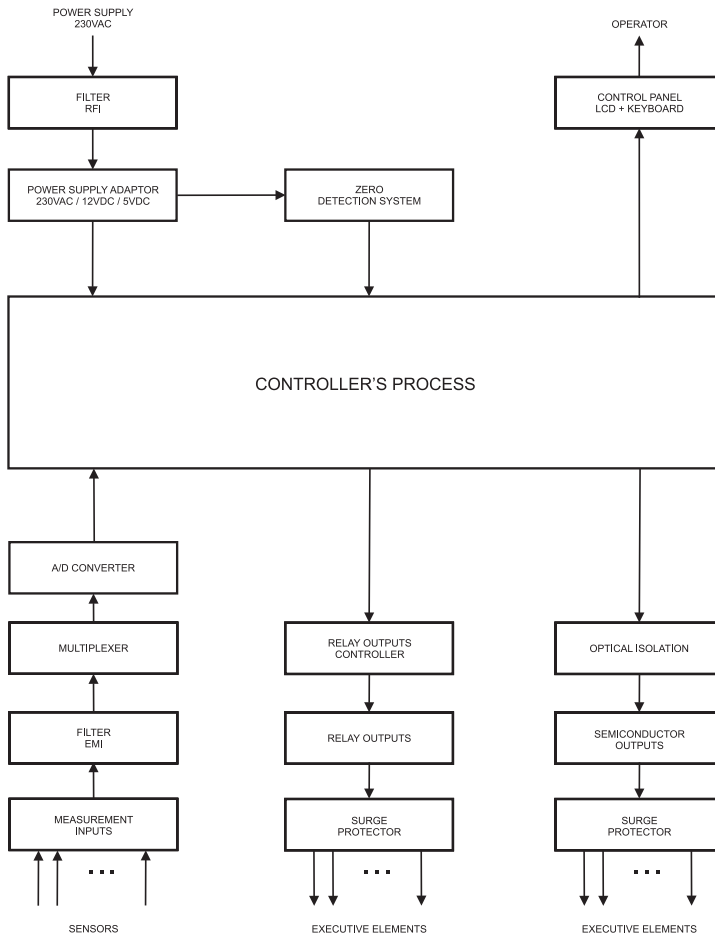

Rys 2. Controller's block diagram.

4. Technical data.

4.1. Dimensions.

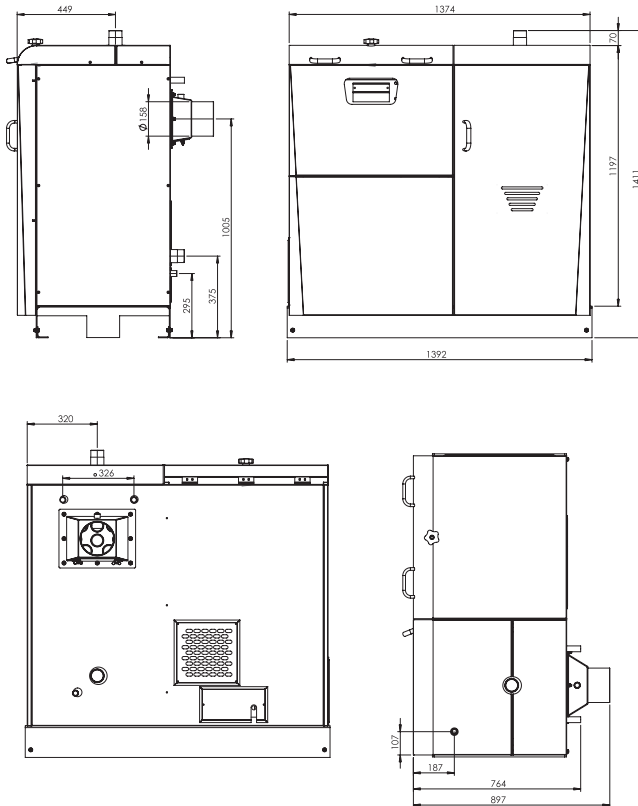

4.2. Boiler technical data.

L.p.	Description	j.m.	Value
1.	Boiler output	kW	25
2.	Power range	kW	from 7 to 25
3.	Boiler class	acc. norm EN 303-5	3 (highest)
4.	Efficiency	%	~92
5.	Fuel: pellets		
	length	mm	10-50
	diameter	mm	6-8
	moisture content	%	8-12
6.	Fuel consumption:		
	nominal	kg/h	5,5
	minimal	kg/h	1,5

L.p.	Description	j.m.	Value
7.	Approximate heating space	m ²	to 250
8.	Max working pressure	bar	2,5
9.	Max water temp.	°C	85
10.	Min. return water temp.	°C	60
11.	Flue diameter	mm	160
12.	Required chimney draught	mbar	from 0,1 to 0,2
13.	Fumes temp: nominal minimal	°C	160 130
14.	Fumes flow: nominal minimal	kg/s kg/s	0,02 0,01
15.	Weight	kg	320
16.	Water capacity	l	60
17.	Hopper capacity	l	255
18.	Loading opening dimensions width/length	mm	260/432
19.	Cooling coil water temperature	°C	10
20.	Min water pressure in cooling coil	bar	2
21.	Voltage/Frequency AC	V/Hz	230/50
22.	Auxiliary power	W	250
23.	Recommended capacity of accumulation tank	litres	1000-2000

4.3. Controller's technical data .

L.p.	Description	j.m.	Value
1.	Power AC	~V/Hz	230/50±10%
2.	Power consumption (controller)	VA	<5
OUTPUT LOAD			
3.	Central heating pump	W	100
4.	Hot water pump	W	100
5.	Buffer pump	W	100
6.	Heater	W	400
7.	Blower	W	150
8.	Gear-motor 1	W	200
9.	Gear-motor 2	W	150
10.	Mixing valve actuator	W	50
11.	Boiler temp. range	°C	60-85
12.	Hot water temp. range	°C	35-70
13.	Measurement accuracy	°C	±2
14.	Ambient temperature	°C	0-60
15.	Moisture content	%	5-95 without condensation
16.	Alarm temp. - range	°C	80-95

4.4. Electric data of gear-motors.

Lp.	Description	j.m.	Value
1.	Type – motor with gear	-	-
2.	Voltage AC	~V/Hz	230/50
3.	Pole number	P	2
4.	Motor characteristic without load Power Input power Rotation speed Start voltage	A W rot/min V	0,65 ± 15% 72 ± 15% 5,4 ± 10% 161 MAX
5.	Load characteristic – after 1 min since start of motor Limit load Acceptable load Start load	Nm Nm Nm	33 MIN 25 MIN 20 MIN
6.	Max current	A	1,2 MAX
7.	Dielectric resistance Motor resistant voltage: 1500V RMS through 1 min (1800V RMS through 1 sec) measured between coil and motor's core (test current 3 mA)	-	-
8.	Insulation coefficient 100 MΩ minimum at 500V of voltage measured between coil and cover	-	-
9.	Thermal protection: Motor protected up 120°C	-	-
10.	Insulation class	klasa	„E”

4.5. Heater's technical data

L.p.	Description	j.m.	Value
1.	Lubrication – Mineral oil and grease	-	-
2.	Noisness (without load)	dB	25 MAX
3.	Weight	kg	2,2
4.	Shaft position - horizontal	-	-
5.	Shift	-	1 : 532

4.6. Heater's technical data

L.p.	Description	j.m.	Value
1.	Type - GLO 120 - 400	-	-
2.	Input voltage range (cooperate with adapter 230/120 VAC)	V-AC	120 -15%/+10% (102 – 132)
3.	Current	A/V-AC	3,3 - 4,2/120
4.	Heater power	W	400
6.	Heater temperature	°C	1200
7.	Time for warm. up to 1200°C	sek.	>12
9.	Heater material: ceramic – recrystallised Si3N4	-	-
10.	Safety norm CSA	-	-

5. Boiler's electric scheme.

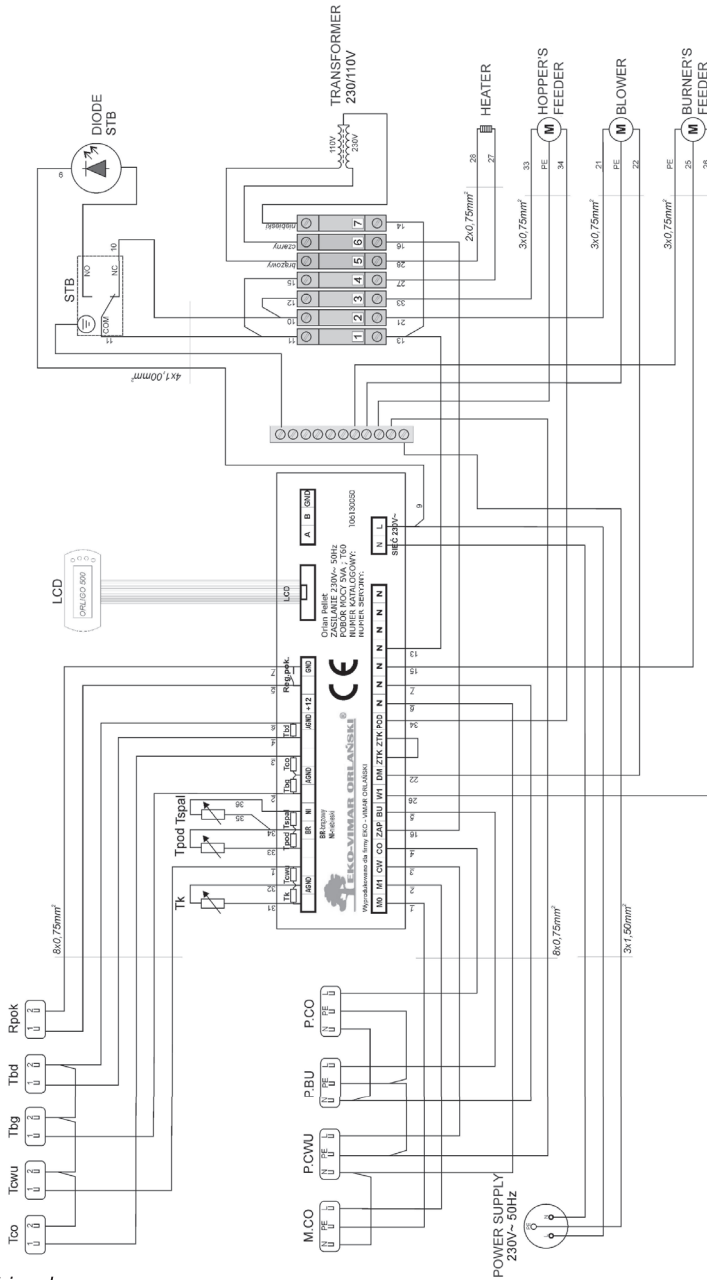

Pic.3 Electric scheme.

Electric connection of equipment to the boiler's controller.

Low-voltage contact

Tco- temperature sensor connection for central heating

Tcwu- sensor connection for hot water pump

Tbg- sensor connection in upper part of the buffer

Tbd- sensor connection in down part of the buffer

Rpok- room thermostat connection

High-voltage contact

M.co- mixing valve's actuator connection

P.cwu- hot water pump connection

P.bu- buffer pump connection – pump responsible for maintaining right return temperature to the boiler

P.co- central heating pump connection

Room thermostat

Controller enables to cooperate with any room thermostat with closing contact.

Room thermostat should be installed in a representative room in the house with respect to temperature at 1,5-2m height.

One shouldn't install room thermostat close to any heat source (TV, radiator), direct sun radiation or places exposed to draught.

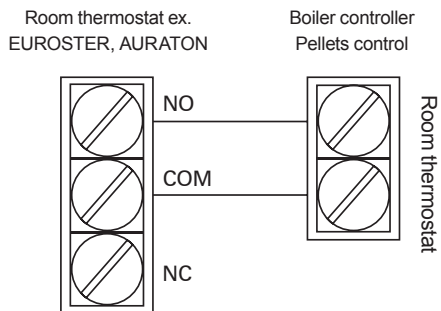

Pic.4 Room thermostat connection.

6. Boiler connection.

6.1. Connection scheme.

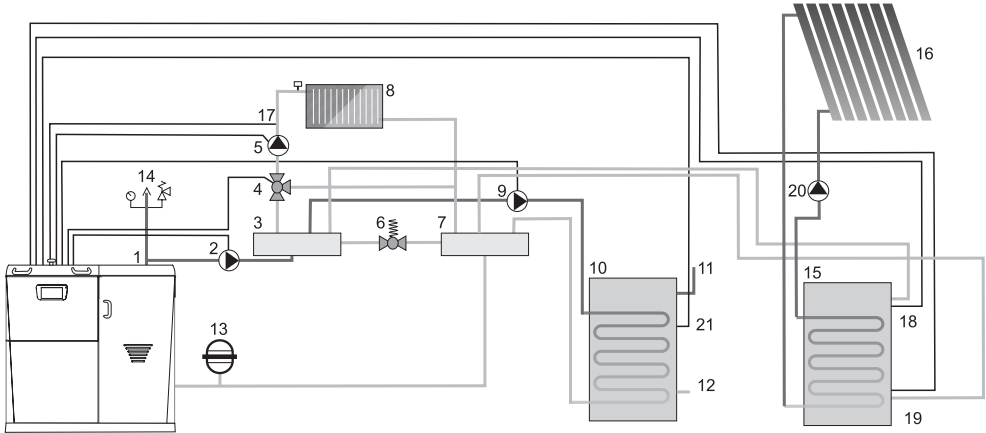

Pic.4 Boiler connection scheme.

Connection scheme

1. Pellet boiler ORLIGNO 500
2. Buffer-boiler pump
3. Supply manifold
4. Three-way mixing valve 230V
5. Circulation pump
6. Differential valve
7. Return manifold
8. Radiator
9. Hot water pump
10. Hot water tank
11. Hot water outlet
12. Cold water inlet
13. Pressure tank
14. Safety group
15. Buffer tank
16. Set of solar collectors
17. central heating sensor
18. Upper part sensor
19. Down part sensor
20. Solar collector pump
21. Hot water measurement

6.2. Hydraulic connections.

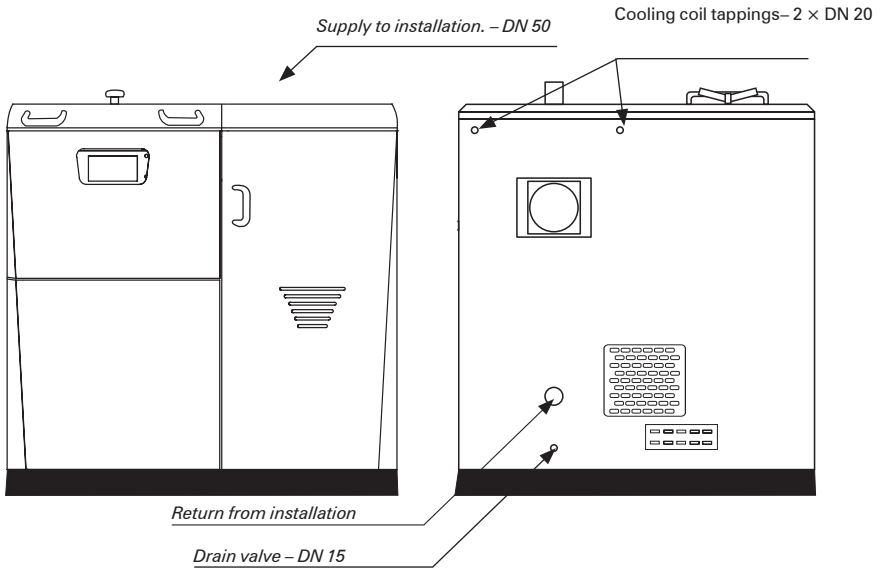

6.3. Cooling coil

In connection with thermostatic valve BVTS it protects the boiler from overheating. Cooling coil needs to be connected to cold water installation through thermostatic valve BVTS. Cooling coil outlet should be directed to drains.

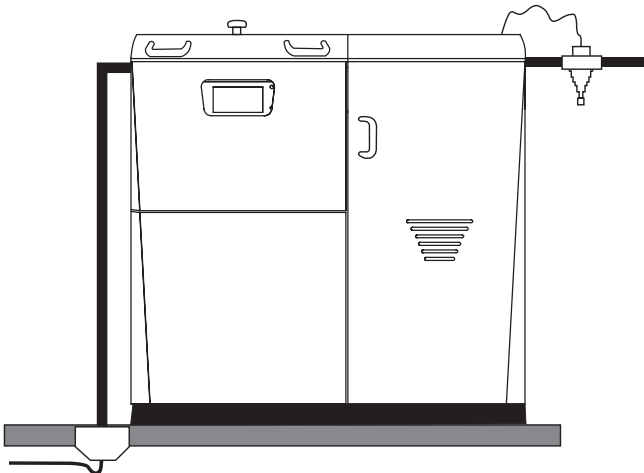

Pic. 5 BVTS connection scheme

7. Boiler tightness

It is very important to assure boiler tightness especially: door tightness. Leakiness causes that fumes may get out to the boiler room and lead to uncontrolled burning. To assure proper door tightness, rope need to be checked periodically and in case of damage - replaced. Insulation rope in bottom door need to greased at least once a month with oil or graphite grease.

8. Ventilation

According to european safety regulations each boiler room should have supply-exhaust ventilation ensuring correct boiler operation and user's safety. Lack of ventilation or its obstruction is the main reason of incorrect boiler operation (i.e. boiler cannot reach set temperature). Exhaust ventilation removes from boiler room used air and harmful gases. Boiler room with natural draught cannot have installed mechanical ventilation.

8.1. Supply air ventilation.

1. Ventilating duct section should have at least 50% area of chimney's section and not less than 20 x 20 cm. Duct should be placed 1m above the floor.
2. Ventilating duct should have installed device for air flow control; device shouldn't limit duct section above 1/5. Ventilating duct should be made of non-inflammable material.

8.2. Exhaust ventilation

1. Exhaust duct should be made of bricks with section of at least 25% of chimney section not less 14 x 14 cm. Inlet hole cannot have any devices that reduce its section. Outlet hole should be placed close to the ceiling led out 1,5 m above the roof. Ventilating duct should be made of non-inflammable material.
2. Height of the boiler room min. 2,2 m.

9. Chimney connection

Chimney ducts should be installed according to binding rules and norms in countries to which boilers are sold.

Part of chimney system connection boiler with chimney is called flue. In order to lower flow resistance of exhaust gases this part should lead as a straight pipe with, if necessary, joints up to 45°

Because of exhaust gases temperature ORLIGNO 500's need to be connected to chimney system protected against condensate soaking.

30 cm above the floor closing door should be installed with tight closing.

Chimney section should be round or close to square shape because of low flow resistance. Minimal flue diameter at least 160 mm

Chimney should lead above the roof. Chimney outlet location is dependent on roof slope and its combustibility.

Eko-Vimar Orłański Ltd. recommends to install draught regulator which stabilizes chimney draught.

10. Troubleshooting

Symptom	Reason	Action
Alarm: No fire/fuel	Lack of fire	Refill hopper acc. to point „Lightning up“
Boiler cannot reach programmed temp.	Wrong lightning up	Check „Lightning up“
	Too moisture pellet	Check moisture – use pellet with required parameters
	Clogged primary air channels	Call service – after-warranty service
	Clogged heat exchanger's pipes	Clean pipes or call service – after warranty service
	Damaged gasket on blower's or burner's flange	Replace – after-warranty service
	Damaged blower	Replace – after-warranty service
Boiler is fuming	Clogged or unproper chimney	Get the chimney-sweeper opinion
	Strong wind forces fumes into the chimney	Consider installation of devices regulating chimney draught
Door is fuming	Gasket leak	Regulate the door's hinges
	Damaged rope	Replace the rope – after-warranty service
Controller doesn't work	No voltage in the grid	Check the protection devices in the electric installation
	Damaged wire	Wire and connection control
	Damaged controller	Call the service
Loud blower operation	Damaged bearings	Call the service - replace the blower
	Damaged capacitor	Call service – replace the capacitor
	Loosen fixing of blower	Fixing control, screw in
	Dirty rotor blades	Control, cleaning

11. Ending



Present appliance is marked according to European Directive 2002/96/EC on waste electrical and electronic equipment.

Symbol placed on the components or attached documents means that appliance is not classified as a household waste.

Scrapping should take place in special collection point in order to reuse electrical and electronic components.

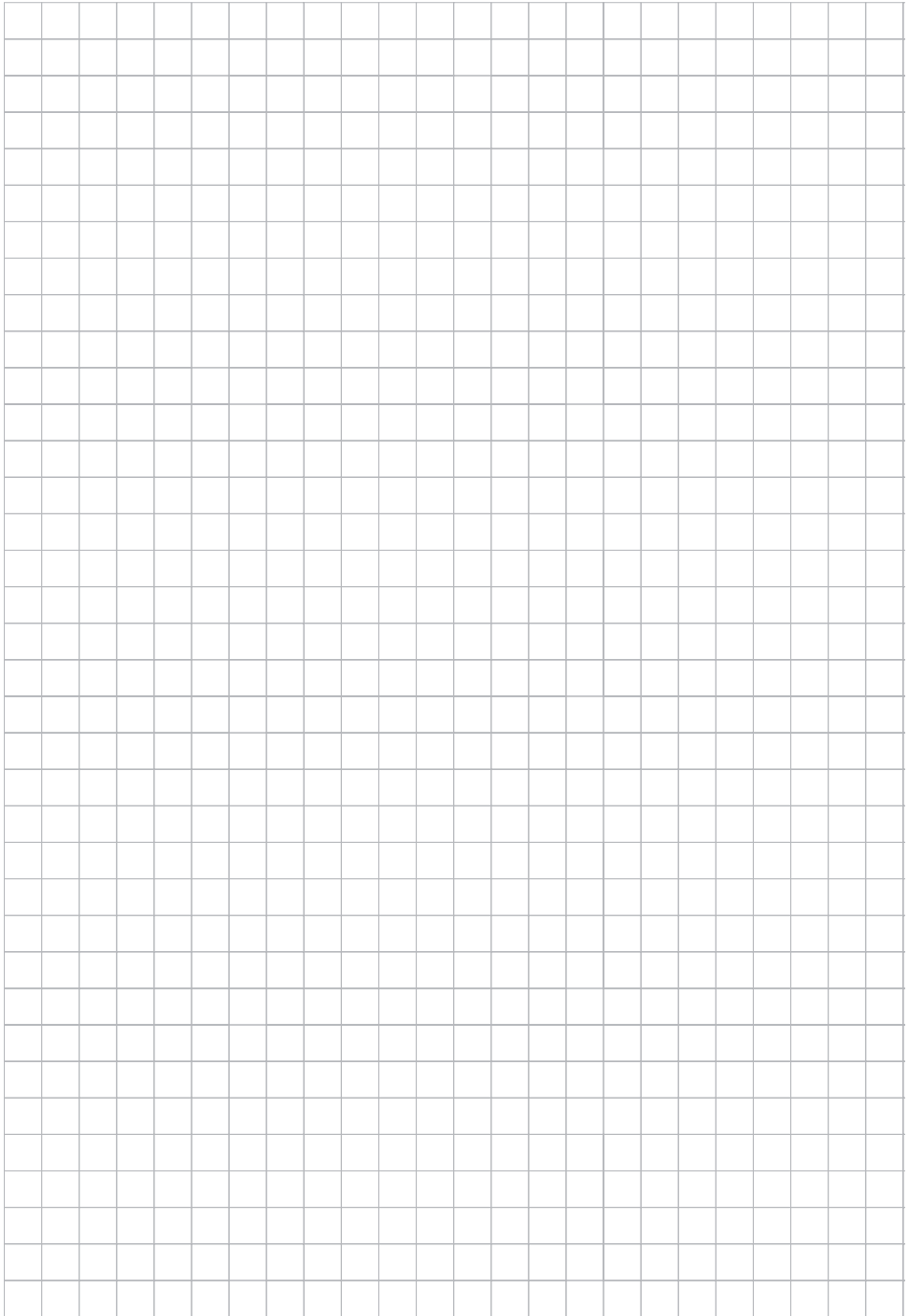

EKO-VIMAR ORLAŃSKI Sp. z o.o.

48-385 Otmuchów, ul. Nyska 17b

POLSKA / woj. opolskie

T +48 77 400 55 80-81, 400 55 91

F +48 77 439 05 03, 400 55 96

E biuro@orlanski.pl

www.orlanski.pl