

MARGHERITA EVO STONE

WOOD COOKER



Free your imagination in the kitchen thanks to the ingenious «PANEPIZZA» patented device. A single large door encloses two independent ovens: manage as much heat as you want, the upper oven is able to exploit higher temperatures thanks to a dedicated smoke path. Both ovens have a soapstone base and a dedicated thermometer. Water, baking powder and flour and a little magic happens in the house. Three seemingly very simple ingredients able to create something incredibly special and fragrant, which unites the whole family.

Heatable area

110 m².





- 1 - Smoke outlet Ø 130mm
- 2 - Polished cast iron hob complete with cast iron rims
- 3 - Secondary air regulation device
- 4 - Cast iron frame
- 5 - Cast iron firebox door
- 6 - Cast iron combustion chamber (HxWxD - 296x305x453)
- 7 - Loading mouth (LxH - 284x273)
- 8 - Precious soapstone
- 9 - Device for primary air regulation
- 10 - Tool compartment
- 11 - Enamelled oven (HxWxD-307x323x433)
- 12 - Upper enamelled oven with soapstone base (HxWxD-100x323x433)



DIMENSIONS

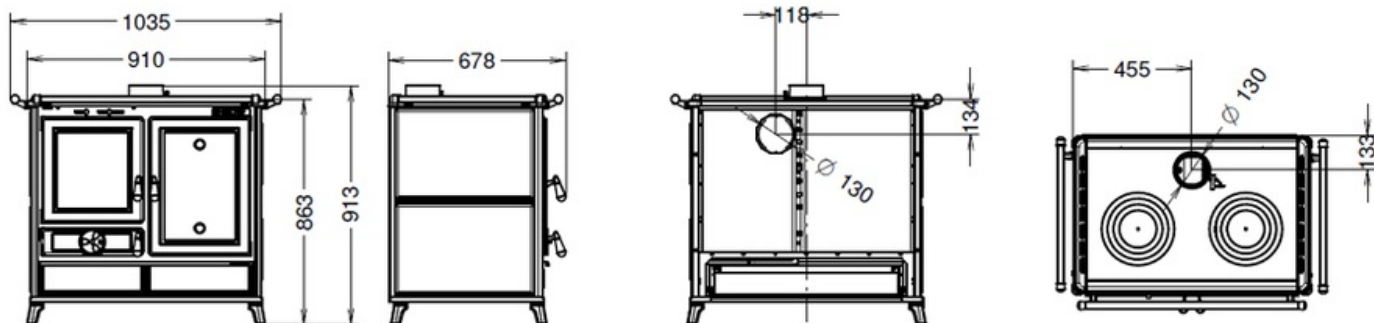

TECHNICAL DATA

DIMENSIONS (HXWXD)	913X912X678
WEIGHT (KG)	232,00
HEATABLE AREA (M ²)	110
EFFICIENCY UP TO MAX (%)	89,0%
ENERGY CLASS	A+
POWER TO THE HEART (KW)	13,8
RATED POWER (KW)	12,3

POWER TO THE WATER (KW)	-
RADIATION (KW)	10,1
HOURLY PELLET CONSUMPTION (KG/H)	-
WOOD HOURLY CONSUMPTION (KG/H)V	3,2
PELLET HOPPER CAPACITY (KG)	-
WARM AIR DUCTING	-
MAXIMUM SINGLE DUCTING OUTLET (M)	-
PATENTED BURNER PELLETPOWER®	-
ROMM VENTILATION	-
PRIMARY AIR FROM OUTSIDE	-
CO EMISSIONS (MG/M³; 13% DI O2)	760
CO EMISSIONS (MG/M³; 10% DI O2)	-
DUST EMISSIONS (MG/M³; 13% DI O2)	8,0
DUST EMISSIONS (MG/M³; 10% DI O2)	-
SILENCE(DB)	-
REMOTE CONTROL	-
RADIO CONTROL WITH ROOM TEMPERATURE THERMOSTAT	-
WEEKLY PROGRAMMER (3 DAILY LIGHTING)	-
SMART INFO FUNCTION	-
SYSTEM CIRCULATING PUMP	-
EXPANSION TANK	-
OVER PRESSURE VALVE	-
FLUE GASEXHAUST DIAMETER (MM)	130
MIN. FLUE DRAUGHT PRESSURE (PA)	12
ELECTRIC CONSUMPTION (WATT)	-
HIGH TEMPERATURE SAFETY THERMOSTAT	-

THERMOROSSI S.p.A.

Via Grumolo, 4 | 36011 Arsiero (VI) | Italy | E-mail: info@thermorossi.it

Tel: 800.44.88.77 | Fax: 0445 741657 | P.IVA 00168470243 | Iscr. REA99797 Vicenza | Cap. Sociale di 156,000,00 l.v.