

ESSENZA WOOD HP STONE

WOOD STOVE



Wood-burning and air-ducting stove, it performs to an efficiency of more than 87,1% (HP - High Power version). Aromy Wood is equipped with the innovative Smoke by-pass technology: before every wood load and turning on an ad-hoc mechanic device, the stove reduces smoke entering the living zone, firebox covered by the HEATSTONE®. Thanks to the optional AIRBOX venting system, Aromy Wood is able to heat more than one room: it becomes vented and air-ducting with an efficiency up to 91%. Thanks to the AIRBOX System the energy consumption can be reduced of up to 20% compared to a traditional one (remote control and air-filter inclusive as standard).



Heatable area

77 m².



1 - Primary, secondary and tertiary air modulation devices

2 - Smoke by-pass technology reduces the smoke outlet to the living zone before every wood load

3 - Precious ceramic handle with aroma diffusor

4 - Burning room covered by the HEATSTONE®, it optimizes the fuel and reflects the heat to the environment

5 - Large combustion chamber (HxLxP- 331x295x390)

6 - Cast iron and glass inlayed firebox door

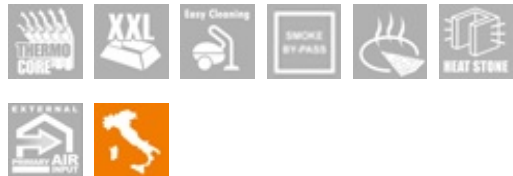

DETAILS



OPTIONAL ACCESSORIES

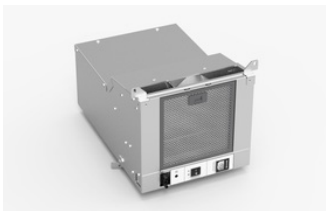

DIMENSIONS

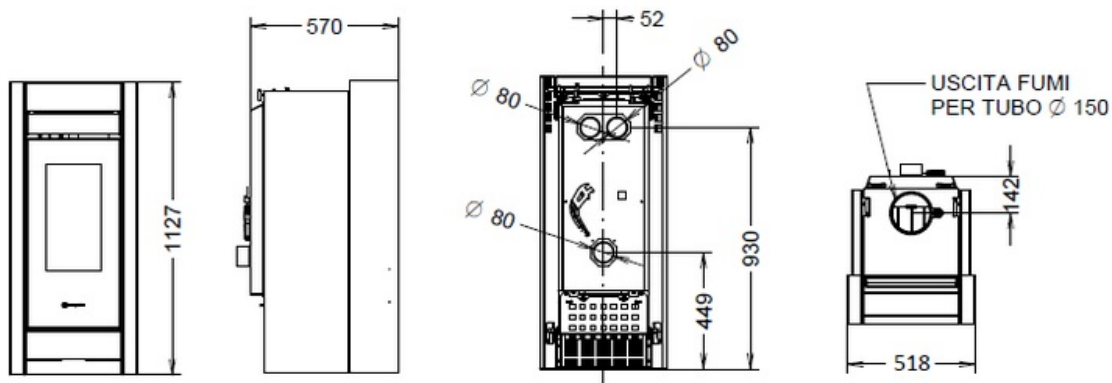

TECHNICAL DATA

DIMENSIONS (HXWXD)	1127X518X570
WEIGHT (KG)	223
HEATABLE AREA (M ²)*A*C	77
EFFICIENCY UP TO MAX (%) *A	87,2%
ENERGY CLASS	A+
POWER TO THE HEART (KW)*A	9,8
RATED POWER (KW)*A	8,5
POWER TO THE WATER (KW)*A	-
RADIATION (KW)*A	8,6
HOURLY PELLET CONSUMPTION (KG/H)*A	-
WOOD HOURLY CONSUMPTION (KG/H)*A	2,3
PELLET HOPPER CAPACITY (KG)*A	-
WARM AIR DUCTING	OPT
MAXIMUM SINGLE DUCTING OUTLET (M)	-
PATENTED BURNER PELLETPOWER®	-
ROOM VENTILATION	OPT
PRIMARY AIR FROM OUTSIDE	SI
CO EMISSIONS (MG/M ³ ; 13% OF O ₂)*A	543,7
CO EMISSIONS (MG/M ³ ; 10% OF O ₂)*A	-
DUST EMISSIONS (MG/M ³ ; 13% OF O ₂)*A	8,8
DUST EMISSIONS (MG/M ³ ; 10% OF O ₂)*A	-
SILENCE (DB)	-
REMOTE CONTROL	-
RADIO CONTROL WITH ROOM TEMPERATURE THERMOSTAT	-
WEEKLY PROGRAMMER (3 DAILY LIGHTING)	-
«SMART INFO» FUNCTION	-
SYSTEM CIRCULATING PUMP	-
EXPANSION TANK	-
OVER PRESSURE VALVE	SI
FLUE GASEXHAUST DIAMETER (MM)	150

MIN. FLUE DRAUGHT PRESSURE (PA)	10
ELECTRIC CONSUMPTION (WATT)	-
HIGH TEMPERATURE SAFETY THERMOSTAT	-

*A EMISSIONS AND PERFORMANCE DATA MAY CHANGE ACCORDING TO THE FUEL USED. THE VALUES OF PELLET PRODUCTS HAVE BEEN OBTAINED BY USING CERTIFIED FUEL ACCORDING TO EN 14961-2 A1-A2 NORM. WOOD LOGS PRODUCTS VALUES MAY VARY ACCORDING TO THE TYPE AND QUALITY OF THE WOOD LOGS USED.

*B PROVISIONAL DATA UNDER CERTIFICATION

*C IMPORTANT: WHEN CALCULATING THE VOLUME OF THE "HEATED AREA" SOME RELEVANT ASPECTS MUST BE CONSIDERED: INSULATION OF THE BUILDING (ENERGY CLASS), POSITION OF THE HEATER, CLIMATIC AREA AND MORE ASPECTS THAT CAN AFFECT THE VALUES OF PERFORMANCE. REPORTED DATA HAVE BEEN CALCULATED ON THE BASE OF ROOF NOT HIGHER THAN 3 MTS.

THE MANUFACTURER RESERVES THE RIGHT TO MAKE CHANGES WITHOUT PREVIOUS NOTICE.

THERMOROSSI S.p.A.

Via Grumolo, 4 | 36011 Arsiero (VI) | Italy | E-mail: info@thermorossi.it

Tel: 800.44.88.77 | Fax: 0445 741657 | P.IVA 00168470243 | Iscr. REA99797 Vicenza | Cap. Sociale di 156.000,00 I.v.