



**LEARN MORE WITH
OUR HOW-TO VIDEOS**

www.youtube.com/FroniusSolar

Fronius Smart Meter 50kA-3

Operating Instructions

EN

System monitoring

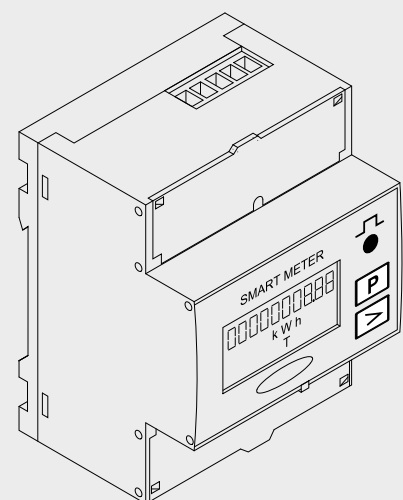

Dear reader,

Introduction

Thank you for the trust you have placed in our company and congratulations on buying this high-quality Fronius product. These instructions will help you familiarise yourself with the product. Reading the instructions carefully will enable you to learn about the many different features it has to offer. This will allow you to make full use of its advantages.

Please also note the safety rules to ensure greater safety when using the product. Careful handling of the product will repay you with years of safe and reliable operation. These are essential prerequisites for excellent results.

Explanation of safety symbols



DANGER! Indicates immediate and real danger. If it is not avoided, death or serious injury will result.



WARNING! Indicates a potentially dangerous situation. Death or serious injury may result if appropriate precautions are not taken.



CAUTION! Indicates a situation where damage or injury could occur. If it is not avoided, minor injury and/or damage to property may result.



NOTE! Indicates a risk of flawed results and possible damage to the equipment.

IMPORTANT! Indicates tips for correct operation and other particularly useful information. It does not indicate a potentially damaging or dangerous situation.

If you see any of the symbols depicted in the "Safety rules" chapter, special care is required.

Contents

Safety rules	7
General	7
Environmental conditions	7
Qualified service engineers	8
Copyright	8
Data protection	8
Warning notices on the device	8
Installation	9
Checklist for installation	9
Mounting	9
Protective circuit	9
Cabling	10
Connecting the current transformers	12
Cabling of the current transformers	12
Suitable voltage transformers	12
Connecting the data communication cable	12
Terminating resistors	13
Configuring the web interface	14
Setting the transformation ratio of the current and voltage transformers	14
Multi-meter system	14
Setting the address of the Fronius Smart Meter	15
Operation	17
Menu structure	17
Technical data	18
Technical data	18
Fronius manufacturer's warranty	20

Safety rules

General



The device is manufactured using state-of-the-art technology and according to recognised safety standards. If used incorrectly or misused, however, it can cause:

- injury or death to the operator or a third party,
- damage to the device and other material assets belonging to the operator,
- inefficient operation of the device.

All persons involved in commissioning, maintaining and servicing the device must

- be suitably qualified,
- have knowledge of and experience in dealing with electrical installations and
- read and follow these operating instructions carefully.

The operating instructions must always be at hand wherever the device is being used. In addition to the operating instructions, attention must also be paid to any generally applicable and local regulations regarding accident prevention and environmental protection.

All safety and danger notices on the device

- must be in a legible state,
- must not be damaged,
- must not be removed,
- must not be covered, pasted or painted over.

The terminals can reach high temperatures.



Only operate the device when all protection devices are fully functional. If the protection devices are not fully functional, there is a risk of

- injury or death to the operator or a third party,
- damage to the device and other material assets belonging to the operator,
- inefficient operation of the device.

Any safety devices that are not functioning properly must be repaired by a suitably qualified engineer before the device is switched on.

Never bypass or disable protection devices.

For the location of the safety and danger notices on the device, refer to the "General" section in the operating instructions for the device.

Before switching on the device, rectify any faults that could compromise safety.

This is for your personal safety!

Environmental conditions



Operation or storage of the device outside the prescribed area will be deemed as "not in accordance with the intended purpose". The manufacturer shall not be held liable for any damage arising from such usage.

For exact information on permitted environmental conditions, please refer to the "Technical data" in the operating instructions.

Qualified service engineers



The servicing information contained in these Operating Instructions is intended only for the use of qualified service engineers. An electric shock can be fatal. Do not perform any actions other than those described in the documentation. This applies even if you are qualified to do so.



All cables and leads must be secured, undamaged, insulated and adequately dimensioned. Loose connections, scorched, damaged or inadequately dimensioned cables and leads must be immediately repaired by authorised personnel.



Maintenance and repair work must only be carried out by authorised personnel.

It is impossible to guarantee that bought-in parts are designed and manufactured to meet the demands made of them, or that they satisfy safety requirements. Use only original spare parts (also applies to standard parts).

Do not carry out any modifications, alterations, etc. to the device without the manufacturer's consent.

Components that are not in perfect condition must be replaced immediately.

Copyright



Copyright of these operating instructions remains with the manufacturer.

The text and illustrations are all technically correct at the time of printing. We reserve the right to make changes. The contents of the operating instructions shall not provide the basis for any claims whatsoever on the part of the purchaser. If you have any suggestions for improvement, or can point out any mistakes that you have found in the instructions, we will be most grateful for your comments.

Data protection

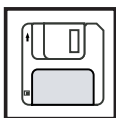

The user is responsible for the safekeeping of any changes made to the factory settings. The manufacturer accepts no liability for any deleted personal settings.

Warning notices on the device

Safety symbols



To avoid electric shocks:

- Do not dismantle or modify the device
- Do not allow any water to enter the device
- Do not allow any foreign substances or material to enter the device
- Do not touch any connections directly



RCM symbol – the product complies with Australian legislative requirements.

Checklist for installation

For information about installation, please refer to the following sections:

- 1 Switch off the power supply before establishing a mains connection
- 2 Mount the Fronius Smart Meter (see "Mounting")
- 3 Connect automatic circuit breakers and disconnectors (see "Protective circuit")
- 4 Connect the mains cable to the Fronius Smart Meter (see "Cabling")
- 5 Mount the current transformers on the conductors. Make sure that the current transformers are pointing in the correct direction. An arrow either points to the load or the source (public grid) (see "Connecting the current transformers")
- 6 Connect the current transformers and the Fronius Smart Meter (see "Cabling of the current transformers")
- 7 Make sure that the current transformer phases match the mains voltage phases (see "Connecting the current transformers")
- 8 Note down the nominal current of the current transformer for each meter. These values will be required during setup.
- 9 Connect the output terminals of the Fronius Smart Meter to the Fronius system monitoring (see "Connecting the data communication cable")
- 10 If necessary, set terminating resistors (see "Terminating resistors")
- 11 Tug on each wire and plug to make sure that they are securely connected to the terminal blocks.
- 12 Switch on the power supply to the Fronius Smart Meter
- 13 Check the firmware version of the Fronius system monitoring. To ensure compatibility between the inverter and the Fronius Smart Meter, the software must always be kept up to date. The update can be started via the inverter web page.
- 14 Set meter location via the Fronius system monitoring web interface under "Settings - Meter - Settings" (see "Configuring the web interface")
- 15 Set the transformation ratio of the current and voltage transformers (see "Setting the transformation ratio of the current and voltage transformers")
- 16 If several Fronius Smart Meters are installed in the system, set the address (see "Setting the address" under Setting the address of the Fronius Smart Meter on page 15)

Mounting

The Fronius Smart Meter can be mounted on a 35 mm DIN rail. The housing comprises 4 modules according to DIN 43880

Protective circuit

The Fronius Smart Meter is a "hard-wired device" and requires a disconnecting device (circuit breaker, switch or disconnector) and overcurrent protection (automatic circuit breaker).

The Fronius Smart Meter consumes just 10-30 mA, so that the nominal capacity of all switches, disconnectors, fuses and/or automatic circuit breakers is determined by the wire gauge, mains voltage and required breaking capacity.

- Switches, disconnectors and circuit breakers must be within sight and located as close as possible to the Fronius Smart Meter; they must also be easy to use.
- Use automatic circuit breakers that are rated for max. 6 A.
- To monitor more than one mains voltage, use connected automatic circuit breakers.
- The automatic circuit breakers must protect the mains terminals, which are marked L1, L2 and L3. In rare cases where the neutral conductor has overcurrent protection, the

overcurrent protection device must interrupt both neutral and non-earthed cables concurrently.

- The circuit protection/disconnecting device must satisfy the requirements of IEC 60947-1 and IEC 60947-3, as well as all national and local regulations for electrical systems.

Cabling

- Always switch off the power supply before connecting the mains voltage inputs to the Fronius Smart Meter.
- Litz wires of the following gauge are recommended for use as mains voltage cables:
 - Screw terminals, measuring input
 - Wire (rigid): min. 0.05 mm² / max. 4 mm²
 - Wire (flexible): min. 0.05 mm² / max. 2.5 mm²
 - Recommended torque: 0.5 Nm / max. 0.8 Nm
- Do not install more than one cable per screw terminal. If necessary, use terminal blocks.

Connect each conductor to the corresponding phase; if necessary, connect the neutral conductor as well. Neutral conductor "N / 11" is not absolutely necessary. As shown in the circuit diagram, the measuring inputs of the current transformers must be earthed on one side.

Connect each voltage cable to the terminal strip as shown in the graphics below.

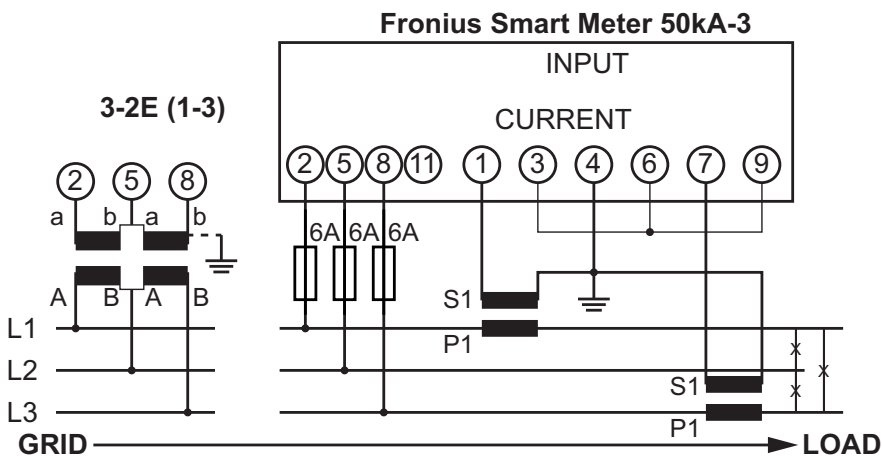
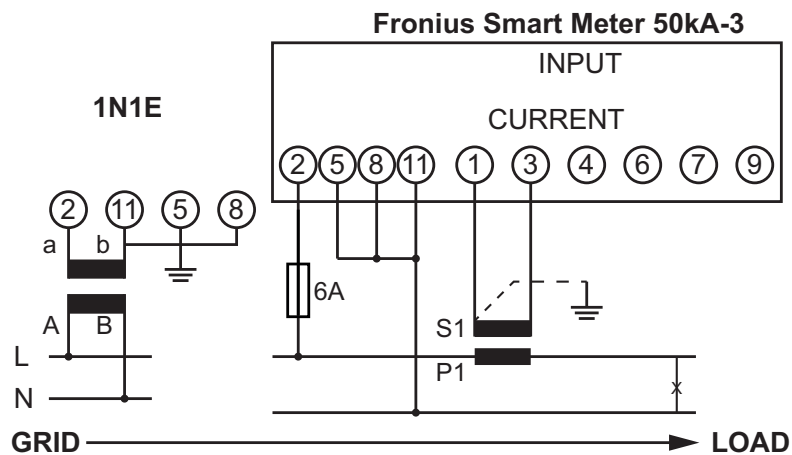

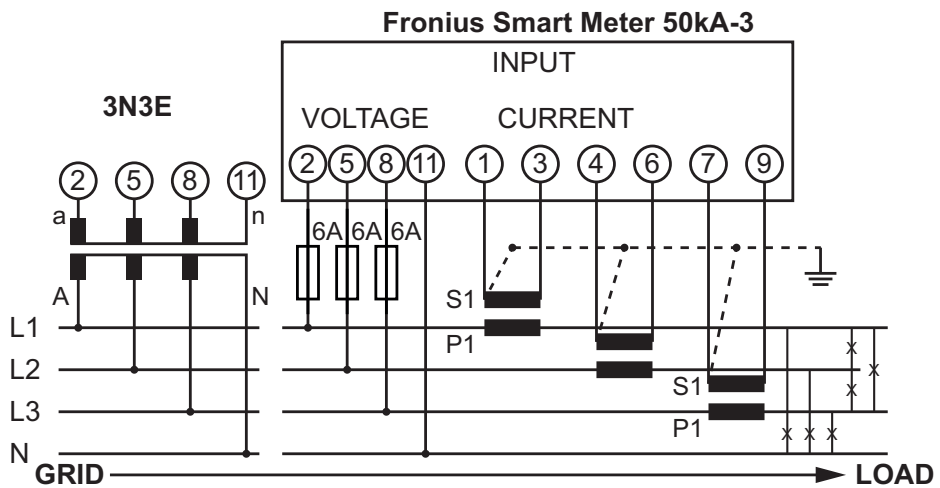
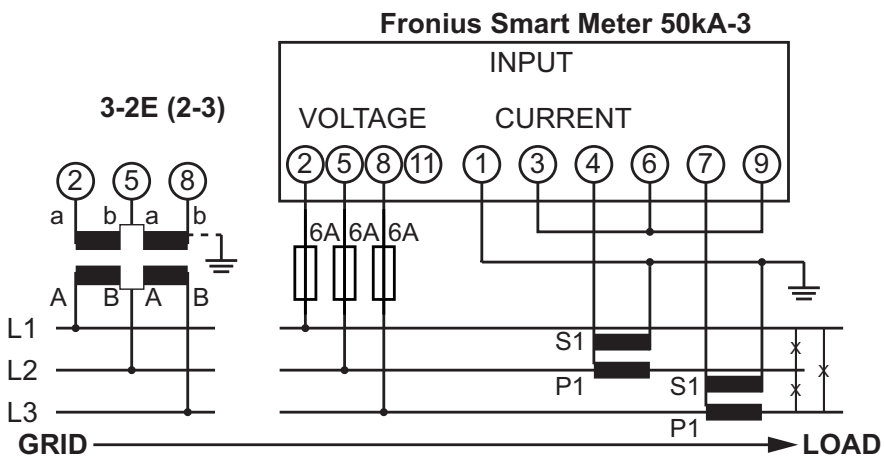
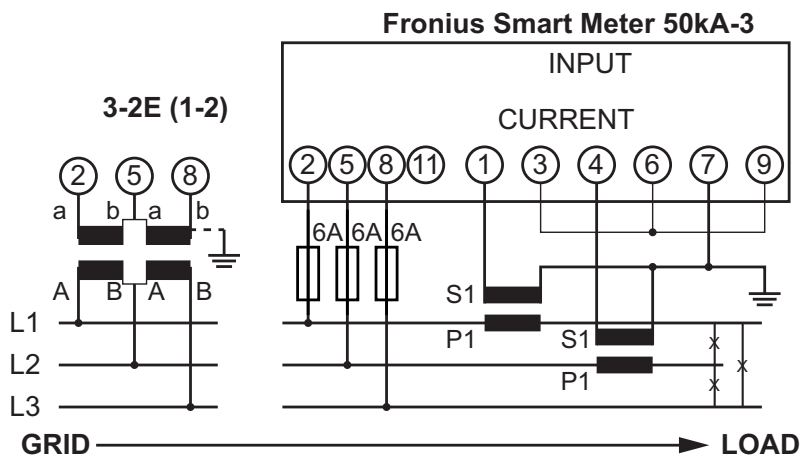
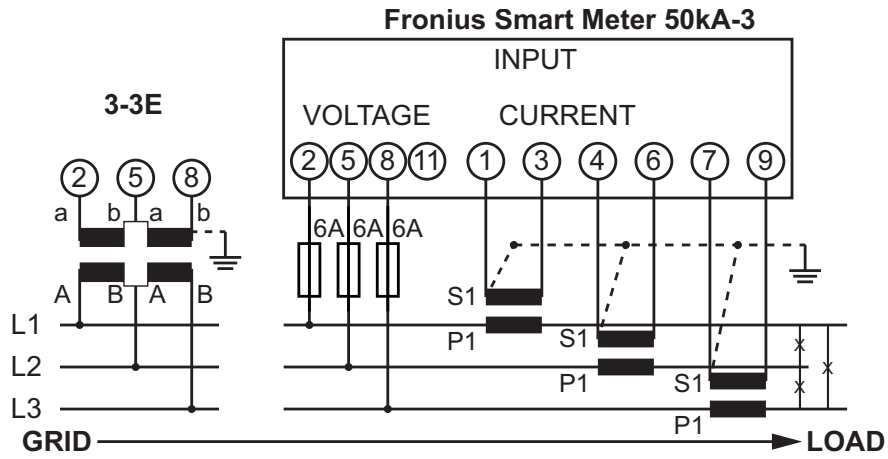

- The outputs of the Fronius Solar Meter are electrically isolated from hazardous voltages.
- If the output cables are close to the mains cabling, use wires or cables that are designed for 300 to 600 V (never less than the operating voltage).
- If the output cables are close to bare conductors, the cables must be double insulated or sheathed.
- Two wires can be installed in each screw terminal; the wires are twisted, inserted into the terminal and tightened. Note: A loose wire can disable an entire area of the network.
- Use shielded twisted pair cables to avoid faults. If there is no common conductor, connect the shield to the - (or C) terminal.
- Cables of type CAT5, CAT5e or CAT6 may be used.

Terminating resistors

The system may work without terminating resistors. However, due to interference, it is recommended that terminating resistors are used as illustrated below.

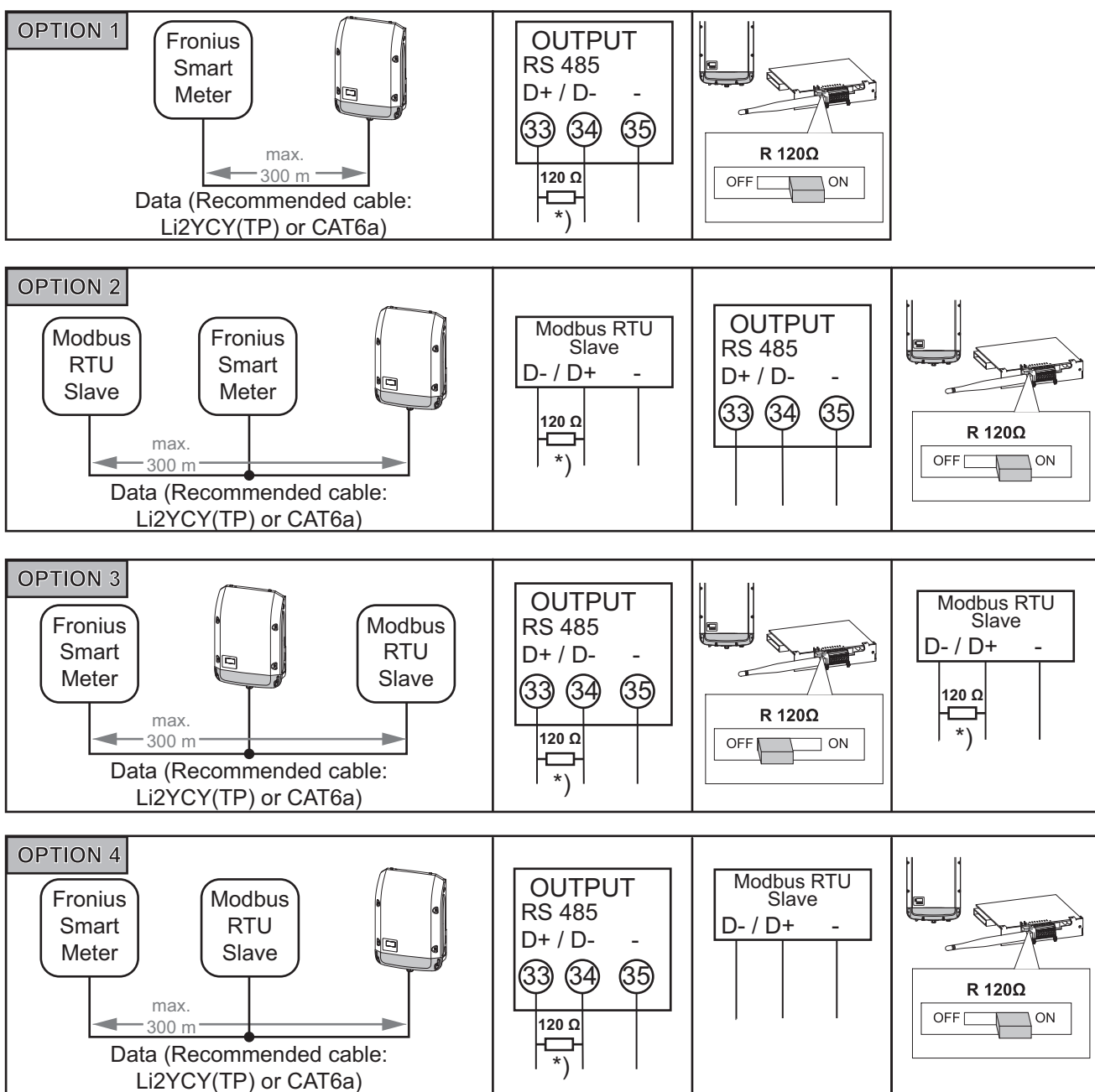

*) the R 120 Ohm terminating resistor is supplied with the Fronius Smart Meter

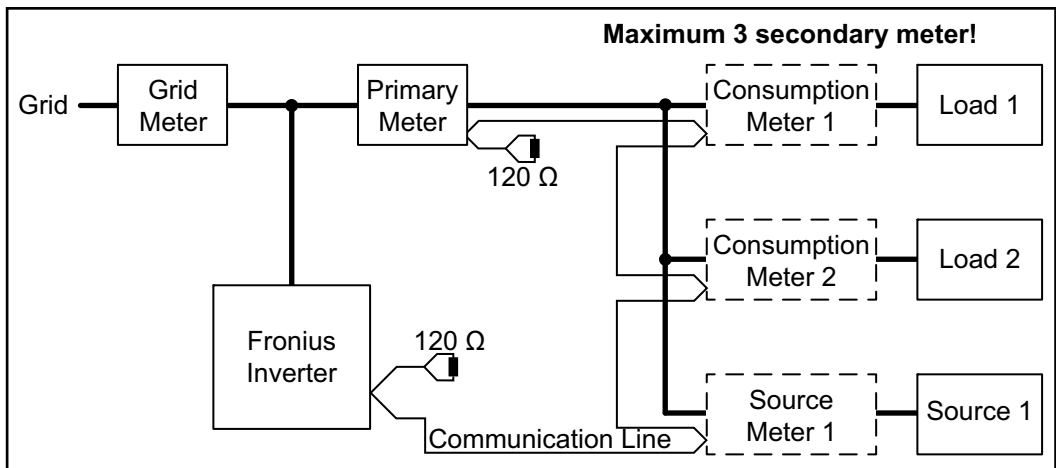

Location of the primary meter in the consumption branch

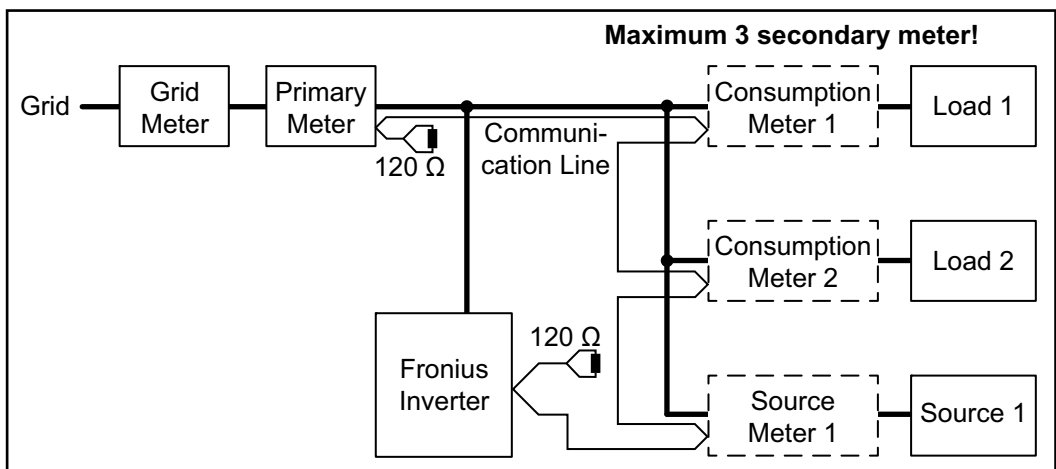

Location of the primary meter at the feed-in point

Setting the address of the Fronius Smart Meter

Set the address of the Fronius Smart Meter:

- 1 Enter the password "2633"

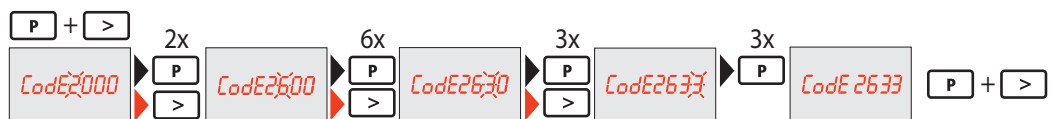

- 2 Select the Address menu item – do not change any other settings!

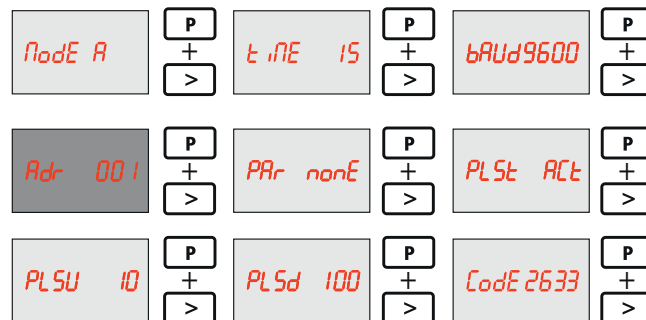

- 3 Set the relevant address

Page Moves the cursor
Prog Increases/decreases the set value
Page + Prog Confirms
Values that can be selected: 1 to 255



Configure Smart Meter in the web interface:

- 1** Open the web interface of the Fronius Datamanager and "Settings"
- 2** Select and add secondary meter
- 3** Enter designation and set Modbus address
- 4** Add meter description
- 5** Repeat the process for additional meters, if necessary

Operation

Menu structure

A graphic view of the menu structure can be found in the User Information that is supplied as standard.

Technical data

Technical data

Modbus transmission speed: 9600 baud

Parity bit: None

Software version: Datamanager 3.7.2 / Energypackage 1.3.3

Input	
Three-phase nominal voltage Operating range	400 - 415 V 210 to 264 V
Single-phase nominal voltage Operating range	230 - 240 V 210 to 264 V
Voltage transformer ratio (kVT)	1 to 1500.0 E.g. VT 600/100V kVT = 6 For direct connection: kVT = 1
Self-consumption - voltage path (max. voltage)	4.5 VA (1.85 W) for 440 V
Nominal frequency Tolerance	50 - 60 Hz 47 to 63 Hz
Nominal current, I _b	1 A + 5 A
Maximum current, I _{max}	6 A
Starting current	20 mA
Current transformer ratio (kCT)	1 to 9,999 E.g. TC 800/5A kCT = 160 For direct connection: kCT = 1
Short-time overload (EN/IEC 62053-21, EN/IEC 62053-23)	20 I _{max} / 0.5 s
Self-consumption - current path (max. current)	0.3 W for phase
Maximum value kVT x kCT	5,000,000 (CT/1A) or 1,000,000 (CT/5A)
Current distortion factor	In acc. with EN/IEC 62053-21
Power factor Operating range (EN/IEC 62053-21, EN/IEC 62053-23)	Active cosφ 0.5 ind to 0.8 cap, Reactive senφ 0.5 ind to 0.5 cap

Energy	
Max. display	As per table
Resolution	As per table
LED indicator	1 pulse / 0.1 Wh
Active energy accuracy (EN/IEC 62053-21)	Class 1
Reactive energy accuracy (EN/IEC 62053-23)	Class 2
Response time after switch-on (EN/IEC 62053-21, EN/IEC 62053-23)	< 5 s

kCT x kVT	Maximum display	Resolution
1 to 9.9	9 9 9 9 9 9 . 9 9	kWh / kvarh 10 Wh / varh
10 to 99.9	9 9 9 9 9 9 9 . 9	kWh / kvarh 100 Wh / varh
100 to 999.9	9 9 9 9 9 9 9	kWh / kvarh 1 kWh / varh

kCT x kVT	Maximum display	Resolution
1000 to 9999.9	9 9 9 9 9 9 . 9 9	MWh / kvarh 10 kWh / varh
≥ 10000	9 9 9 9 9 9 9 . 9	MWh / kvarh 100 kWh / varh

Average power	
Measured variable	Effective power
Calculation	Average value over set period of time
Integration time	5 / 8 / 10 / 15 / 20 / 30 / 60 minutes

Operating hours counter	
Operating hours counter	Hours and minutes
Resolution	7-digit (5 hours + 2 minutes)
Max. display	99,999 h 59 min
Counting start	3-phase effective power
Programmable values	0.10 to 50% P _n
3-phase effective power	In acc. with 400 V 5 A - 3464 W
Operating hours counter reset	Accessible via keypad or locked

Output	
Energy pulse Pulse output compatible with S0 EN/IEC 62053-31 Optical relay with NO contact SPST-NO, floating	
Contact load	110 V DC/AC - 50 mA
Assignable energy	Active or reactive energy
Pulse value	10 Wh (Varh) - 100 Wh (Varh) - 1 kWh (kVarh) - 10 kWh (kVarh) - 100 kWh (kVarh) - 1000 kWh (kVarh)
Pulse duration	50 - 100 - 150 - 200 - 300 - 400 - 500 ms
RS485 communication Electrically isolated from input and auxiliary voltage	
Standard	RS485 - 3 conductors
Transmission	Serial, asynchronous
Protocol	Modbus RTU
Addresses	1 to 255
Number of bits	8
Stop bit	1
Parity bit	None - even - odd
Baud rate	4800 - 9600 - 19200 bit/s
Response time	≤ 200 ms

Insulation (EN/IEC 62052-11, 62053-21)	
Installation category	III
Pollution level	2
Insulation voltage	300 V phase-neutral
Impulse withstand voltage	5 kV 1.2/60 μs
Test circuit	Voltage input, current input, pulse output, communication

Insulation (EN/IEC 62052-11, 62053-21)	
Test voltage Test circuit	2.75 kV r.m.s. 50 Hz / 1 min Voltage input, current input, pulse output, communication
Test voltage Test circuit	4 kV r.m.s. 50 Hz / 1 min All circuits and earth

Electromagnetic compatibility	
Test in acc. with EN/IEC 62052-11	

Operating conditions	
Reference temperature	23°C (±2°C)
Operating range	-5 to 55°C
Temperature limit for storage and transport	-25 to 70°C
Tropical model	
Max. power loss (for thermal dimensioning of the switch cabinet)	≤ 2.8 W

Housing	
Housing	4 modules according to DIN 43880
Sealable front and terminal cover	
Connection	Screw connection
Mounting	Can be snapped onto 35 mm DIN rail
Housing material	Polycarbonate, self-extinguishing
Degree of protection (EN 60529)	IP54 front, IP20 connections
Weight	260 grams

Screw terminals	
Measuring input	
Wire (rigid)	Min. 0.05 mm ² / max. 4 mm ²
Wire (flexible)	Min. 0.05 mm ² / max. 2.5 mm ²
Recommended torque	0.5 Nm / max. 0.8 Nm
Output	
Wire (rigid)	Min. 0.05 mm ² / max. 4 mm ²
Wire (flexible)	Min. 0.05 mm ² / max. 2.5 mm ²
Recommended torque	0.5 Nm / max. 0.8 Nm

Fronius manufacturer's warranty

Detailed, country-specific warranty terms are available on the internet:
www.fronius.com/solar/warranty

To obtain the full warranty period for your newly installed Fronius inverter or storage system, please register at: www.solarweb.com.

Fronius Worldwide - www.fronius.com/addresses

Fronius International GmbH
4600 Wels, Froniusplatz 1, Austria
E-Mail: pv-sales@fronius.com
<http://www.fronius.com>

Fronius USA LLC Solar Electronics Division
6797 Fronius Drive, Portage, IN 46368
E-Mail: pv-us@fronius.com
<http://www.fronius-usa.com>

Under <http://www.fronius.com/addresses> you will find all addresses of our sales branches and partner firms!