

1. Removal/Mounting (fig. 1)

For the ease of removing/mounting the gas section, the complete unit (3) consisting of burner, fan and gas section, shall be removed.

- Close gas cock.
- Turn off boiler as described in the instructions for installation and servicing (Section 7.1.1.)
- Remove front casing as described in the instructions for installation and servicing (Section 7.1.2.)
- Lower control box as described in the instructions for installation and servicing (Section 7.1.3.)
- Lift and remove control panel cross member.
- Remove screw and disconnect air inlet pipe (2).
- Disconnect gas supply from gas valve by undoing union (5).
- Disconnect HT lead and earth lead from spark electrode.
- Remove five nuts from burner manifold.
- Pull forward complete burner, gas valve and fan assembly.
- Disconnect electrical connections from fan and gas valve.
- Remove burner, gas valve and fan assembly from boiler.

 Do not deposit them on the fan motor

- Remove four screws whilst supporting gas valve and fan.
- Separate gas valve and fan assembly from burner manifold.
- Remove two screws securing gas valve to fan.
- Disconnect gas inlet supply connection from gas valve by removing four screws. Refit the gas inlet supply connection to the new gas valve using the new sealing gasket supplied ensuring gas valve is repositioned correctly.
- Fit new gas valve to fan using the new sealing gasket supplied.
- Refit gas valve and fan assembly to burner manifold using the new sealing gasket supplied. Equally tighten the four screws to ensure a good seal is made.

- Reconnect gas supply to gas valve using new sealing gasket supplied. Reconnect electrical connections to Gas valve and fan. Reassemble boiler in reverse order.

 Attention: To position the cork sealing gasket and the gas valve on the fan flange correctly, use the guiding cam. Take care to position them correctly!

- Recommission boiler as detailed in the instructions for installation and servicing (Section 5.)
- After firing the boiler, check the sealing points for leakages.

2. Functional check and setting the gas/air ratio

As the gas valve has not been factory set for operation with natural gas, the valve needs adjustment according to table 1.

If burner does not light screw gas/air ratio factor setting screw one revolution anticlockwise.

2.1 Setting the correct gas/air ratio in case of operation with natural gas (fig 1/2)

Re-fit front casing to boiler. Operate the boiler for at least 3 minutes at the maximum input possible.

Check that the air inlet pipe (2) has been refitted!

- Measure the products at the flue gas analyser test point.
- Compare the measured CO₂ value with the one indicated in the attached table (column A).

In the case that the CO₂ value exceeds the tolerances, correct it as follows:

- Remove front casing from boiler.
- Remove the air inlet pipe (2) and drop pipe forward (do not remove it).
- If the measured CO₂ value is too low, unscrew the gas/air ratio setting screw anticlockwise, position 6, (adjust the CO₂ screw progressing in steps of half a turn and wait approx. 1 minute to see the reaction).

- If the measured CO₂ value is too high, screw the gas/air ratio setting screw clockwise, position 6, (adjust the CO₂ screw progressing in steps of half a turn and wait about 1 minute to see the reaction).

In case the CO₂ value is correct at maximum input, now proceed to check it at the minimum input (only check it, do not adjust the value) as follows:

- Check part load setting and record.
- Set the partial heating load to minimum (see instructions for installation).
- After about 3 to 5 minutes, measure the CO₂ value and compare it to the value indicated in the table (column B). If the CO₂ value is out of tolerance, inform the Vaillant technical service.

If the CO₂ value is correct at minimum input, now check the rated input as follows:

- Re-fix the air inlet pipe (2).
- Remount the combustion chamber cover.
- Operate the boiler at the maximum input possible.
- After operating the boiler for about 5 minutes, measure the gas flow rate in l/min and compare it to the value indicated in table 1 (column C).

If the rated input is not reached (for example because when using a system boiler without a vantage) adjust the lowest input and compare it to the values indicated in table 1 (column D). You can not adjust the input, this step is only to check the function of the gas/air compound control unit.

2.2 Adjust the correct gas/air ratio for operation with LPG (propane)

- Before firing the boiler with the new gas valve built-in, screw-in the gas/air ratio setting screw (position 6) by two turns.

 This is to avoid that the boiler is operated at excess load during the first minutes.

- Proceed then as described under 2.1!



Attention!

Please check in table 1 with which gas types your appliance may be operated. In case there is no CO₂ value, the corresponding gas type must not be adjusted.

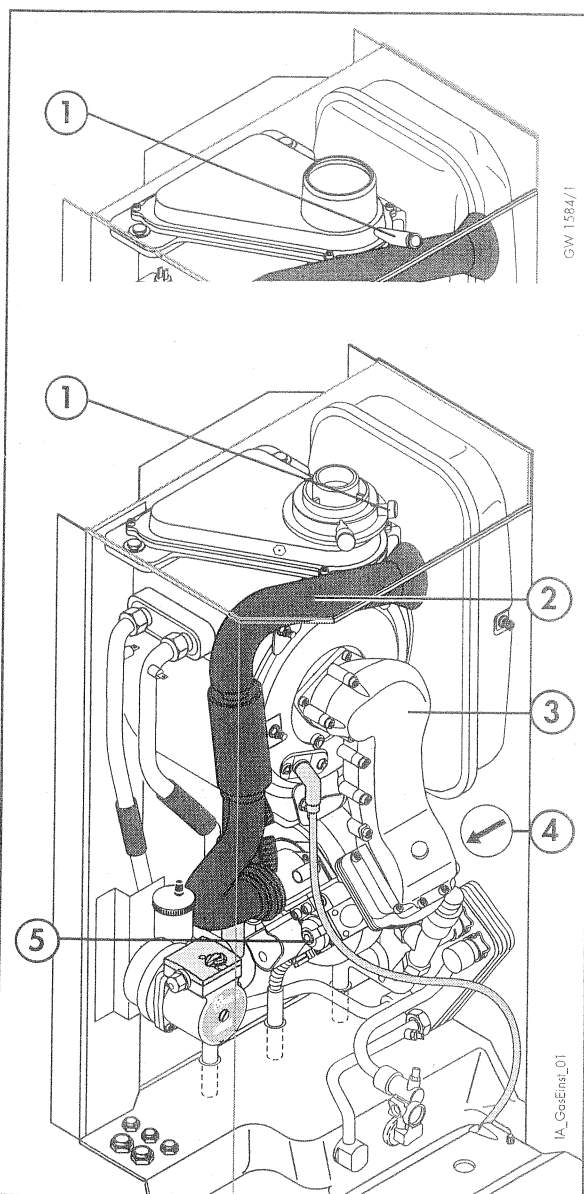

fig. 1

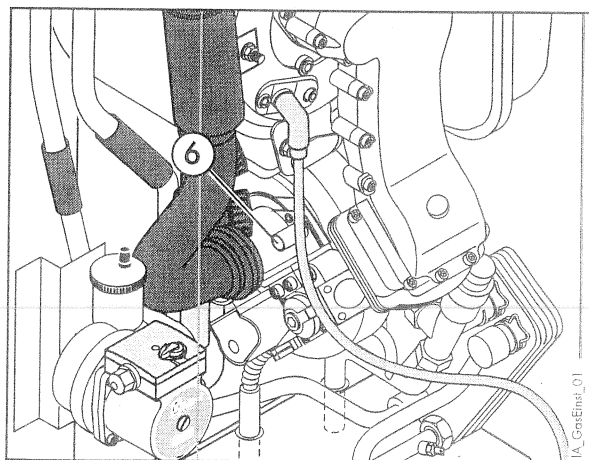

fig. 2: Setting of the air factor