

Data sheet

VZL valve - 2/3/4-way

Description

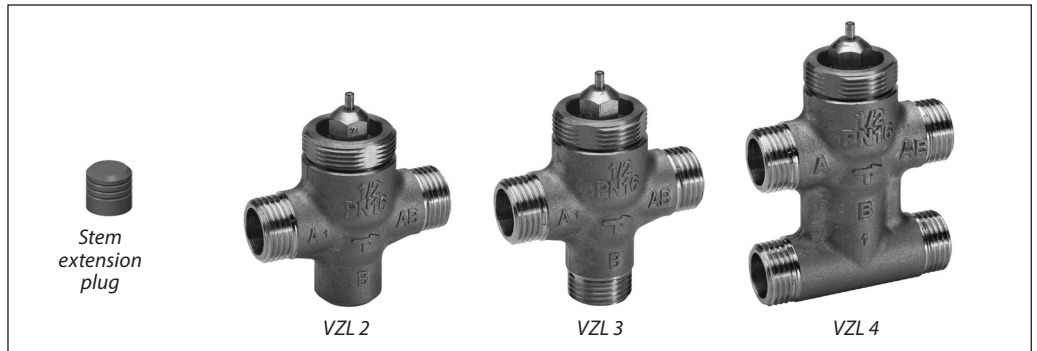

VZL valves provide a high quality, cost effective solution for the control of hot and/or chilled water for fan coil units, small reheaters, and recoolers in temperature control systems.

The valves are used in combination with:

- AMV(E) 130(H)/140(H) ABNM A5 with extension plug;
- AMV(E) 13 (SU) and TWA-ZL actuators.

Note:

TWA-ZL thermal actuator does not close port B.

In case that stem extension plug is not used together with AMV(E) 130(H)/140(H) dead zone in valve close position will occur.

Main data:

- DN 15, 20
- k_{vs} 0.25-3.5 m³/h
- PN 16
- Temperature:
 - Circ. water / glycolic water up to 50 %: 2 ... 120 °C
- Reduced k_{vs} on B port (VZL 3 & VZL 4 only)
- Linear characteristic
- Linear bypass on 3 and 4 port valves
- Valves are supplied with screwed plastic cover for manual operation
- Connections: flat end or conex
- Water quality acc. to VDI 2035 requirements

Ordering

2-way valve **VZL 2**

Picture	DN (mm)	k_{vs} (m ³ /h)	max. Δp (bar)	Code No.	
				Flat End	Conex
	15	0.25	2.5	065Z2070	065Z2040
		0.4	2.5	065Z2071	065Z2041
		0.63	2.5	065Z2072	065Z2042
		1.0	2.0	065Z2073	065Z2043
		1.6	2.0	065Z2074	065Z2044
	20	2.5	1.0	065Z2075	065Z2045
		3.5	1.0	065Z2076	065Z2046

3-way valve **VZL 3**

Picture	DN (mm)	k_{vs} (A - AB)	k_{vs} (B - AB)	max. Δp (bar)	Code No. Flat End
		m ³ /h			
	15	0.25	0.25	2.5	065Z2080
		0.4	0.25	2.5	065Z2081
		0.63	0.40	2.5	065Z2082
		1.0	0.63	2.0	065Z2083
		1.6	1.0	2.0	065Z2084
	20	2.5	1.6	1.0	065Z2085
			3.5	2.5	1.0

Ordering (continued)

4-way valve **VZL 4**

Picture	DN (mm)	k_{vs} (A - AB)	k_{vs} (B - AB)	max. Δp (bar)	Code No.	
		m ³ /h			Flat End	Conex
	15	0.25	0.25	2.5	065Z2090	065Z2060
		0.4	0.25	2.5	065Z2091	065Z2061
		0.63	0.4	2.5	065Z2092	065Z2062
		1.0	0.63	2.0	065Z2093	065Z2063
		1.6	1.0	2.0	065Z2094	065Z2064
	20	2.5	1.6	1.0	065Z2095	065Z2065
		3.5	2.5	1.0	065Z2096	065Z2066

Accessories

Type	Pipe size	DN	Description	Code No.
Tailpieces with external thread	R 3/8"	15	Consist of 2 union nuts, 2 tailpieces and 2 gaskets (Ms 58)	065Z7015
	R 1/2"	20		003H6902
Tailpieces for soldering	12 mm	15	Consist of 2 union nuts, 2 solder bushes and 2 gaskets (Ms 58)	065Z7016
	15 mm	20		065Z7017
Stuffing box				065F0006
Spindle extension adapter, 2 mm (5 pieces)				003Z0249

Technical data

Control characteristic	Linear	
Control range	min. 30:1	
Leakage loss, closed valve	A - AB \leq 0.05 % of k_{vs}	
	B - AB \leq 1 % of k_{vs}	
Medium	Circulation water / Glycolic water up to 50 %	
Medium temperature	°C	2 ... 120
Max. operating pressure	bar	16
Stroke	mm	2.8
Connection	External thread (flat connection (MS 58) or conex)	
Materials		
Body	Brass CuZn40Pb2	
Seat cone and stem	Brass CuZn39Pb3	
Stuffing box	EPDM	

Pressure temperature diagram

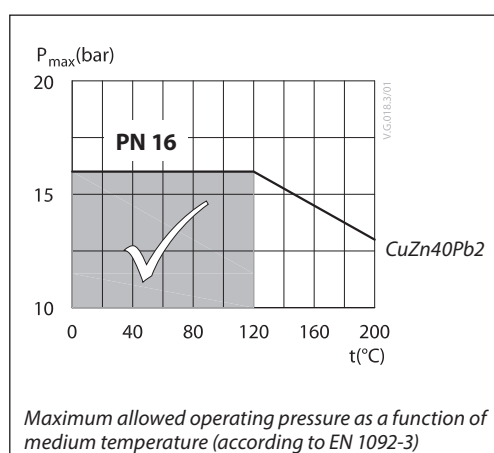

Disposal

The valve must be dismantled and the elements sorted into various material groups before disposal.

Installation

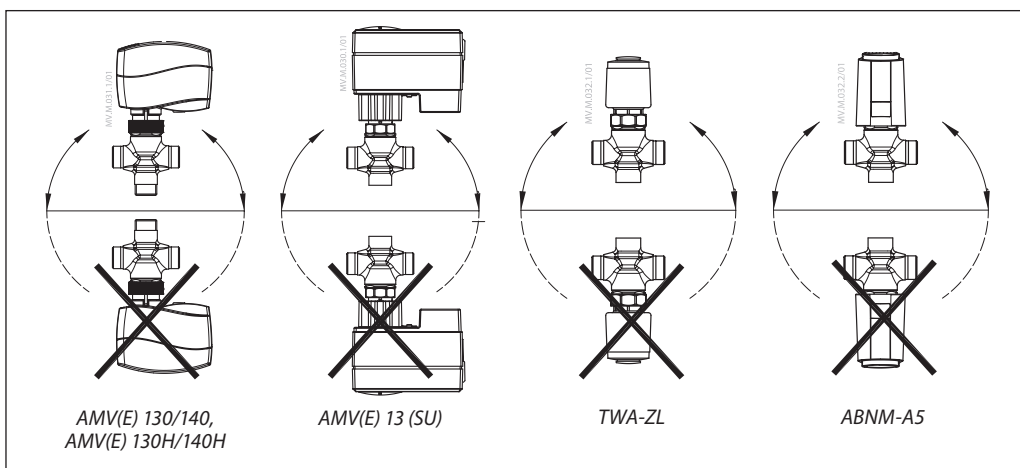

Valve mounting

Before valve mounting the pipes have to be cleaned and free from abrasion. Valve must be mounted according to flow direction as indicated on valve body. Mechanical loads of the valve body caused by the pipes are not allowed. Valve should be free of vibrations as well.

Installation of the valve with the actuator is allowed in horizontal position or upwards. Installation downwards is not allowed.

Application schemes for 3-way and 4-way mixing valves

3-way and 4-way valves are mixing valves meaning that A and B ports are inlet ports, and AB port is outlet port (fig. 1). In case valve should be used as diverting valve it is a solution to install valve in return pipe (fig. 2).



To prevent damages, starting max. Δp must not exceed 1 bar for DN 20 and 2/2.5 bar for DN 15, when installing the valve.

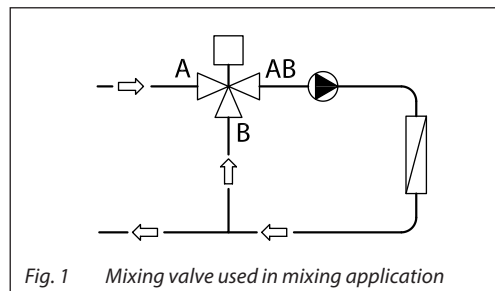

Fig. 1 Mixing valve used in mixing application

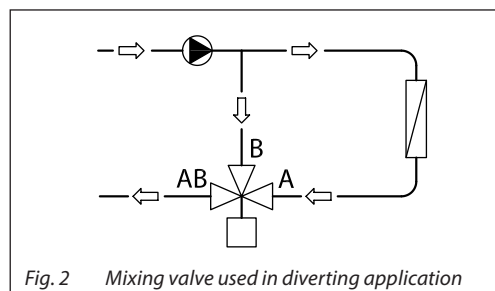
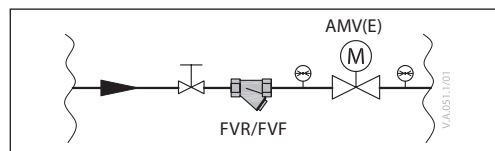

Fig. 2 Mixing valve used in diverting application

Note:
Install a strainer upstream of the valve (e.g. Danfoss FVR/FVF)



Sizing

Example

Design data:

Flow rate: 0.3 m³/h
 System pressure drop: 20 kPa

Locate the horizontal line representing a flow rate of 0.3 m³/h (line A). The valve authority is given by the equation:

$$\text{Valve authority, } N = \frac{\Delta P_1}{\Delta P_1 + \Delta P_2}$$

Where:

ΔP_1 = pressure drop across the fully open valve,
 ΔP_2 = pressure drop across the rest of the circuit with a fully open valve

The ideal valve would give a pressure drop equal to the system pressure drop (i.e. an authority of 0.5):

If $\Delta P_1 = \Delta P_2$,

$$N = \frac{\Delta P_1}{\Delta P_1 + \Delta P_2} = 0.5$$

In this example an authority of 0.5 would be given by a valve having a pressure drop of 20 kPa at that flow rate (point B).

The intersection of line A with a vertical line drawn from B lies between two diagonal lines; this means that no ideally-sized valve is available. The intersection of line A with the diagonal lines gives the pressure drops stated by real, rather than ideal, valves. In this case, a valve with k_{vs} 0.63 would give a pressure drop of 25 kPa (point C):

$$\text{hence valve authority} = \frac{25}{25 + 20} = 0.56$$

The second-largest valve, with k_{vs} 1, would give a pressure drop of 9 kPa (point D):

$$\text{hence valve authority} = \frac{9}{9 + 20} = 0.31$$

Generally, for a 3 port application, the smaller valve would be selected (resulting in a valve authority higher than 0.5, and therefore improved controllability). However, this will increase the total pressure and should be checked by the system designer for compatibility with available pump head, etc.

The ideal authority is 0.5 with a preferred range of between 0.4 and 0.7.

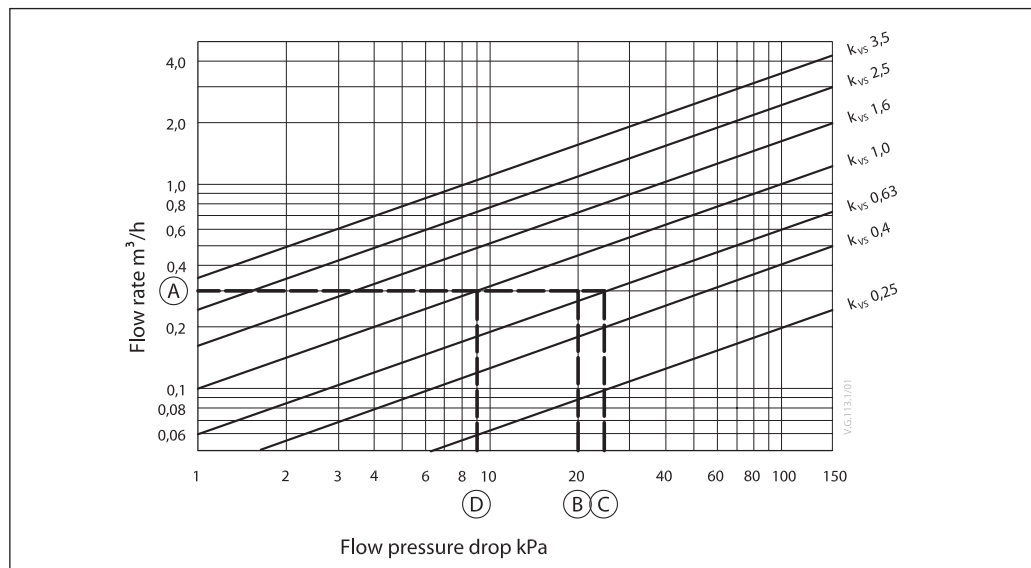

Design

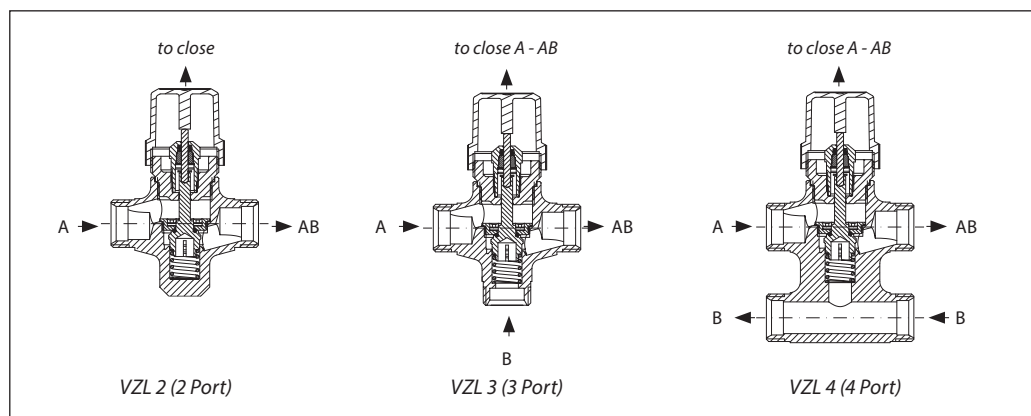

Dimensions

M.V.D.124.1/01

4.7
Ø5
Stem extension plug

92
H
h
L
d
M.V.D.130.1/01

92
H
h
L
d
M.V.D.131.1/01

92
H
h
L
d
M.V.D.137.1/01

AMV(E) 130/140 + VZL 2 + stem extension plug

AMV(E) 130/140 + VZL 3 + stem extension plug

AMV(E) 130/140 + VZL 4 + stem extension plug

92
H₁
L
M.V.D.123.1/01

121
H₂
L
M.V.D.127.1/01

40.5
H₃
L
M.V.D.121.1/01

44.1
H₄
L
M.V.D.125.1/01

AMV(E) 130H/140H + VZL + stem extension plug

AMV(E) 13 SU + VZL

TWA-ZL + VZL

ABNM A5 + VZL + stem extension plug

Valve type	d	mm									Valve weight (kg)	
		L	H	H ₁	H ₂	H ₃	H ₄	c	h	h ₁		
VZL 2 DN 15	G 1/2"	65	111	117	140	88	93.5	-	29.5	47.5	0.27	
VZL 2 DN 20*	G 3/4"	77	117	123	146	94	99.5		34.0		0.47	
VZL 3 DN 15	G 1/2"	65	111	117	140	88	93.5		35.0		0.28	
VZL 3 DN 20	G 3/4"	77	117	123	146	94	99.5		35.0		0.40	
VZL 4 DN 15	G 1/2"	65	111	117	140	88	93.5		40		51.0	0.39
VZL 4 DN 20*	G 3/4"	77	117	123	146	94	99.5		50		65.0	0.59

* conex valves DN 20 - G 1 1/8" 14 TPI

Tailpieces for soldering

G	Ød		L	Weight (kg)
	mm			
1/2"	12		15	0.11
3/4"	15		20	0.17

Tailpieces with external thread

G	R (")	L (mm)	Weight (kg)
1/2"	3/8	23	0.11
3/4"	1/2	26	0.17



Danfoss A/S

Heating Segment • heating.danfoss.com • +45 7488 2222 • E-Mail: heating@danfoss.com

Danfoss can accept no responsibility for possible errors in catalogues, brochures and other printed material. Danfoss reserves the right to alter its products without notice. This also applies to products already on order provided that such alterations can be made without subsequential changes being necessary in specifications already agreed. All trademarks in this material are property of the respective companies. Danfoss and all Danfoss logotypes are trademarks of Danfoss A/S. All rights reserved.
