

# Dynamic thermostatic radiator valves DYNAMICAL®



## 230-231-232-233-234-237 series



**PCT**  
INTERNATIONAL  
APPLICATION  
PENDING

### Function

The DYNAMICAL® valve allows the automatic dynamic balancing and pressure-independent adjustment of the thermal medium in the radiators of two-pipe heating systems.

The device, in conjunction with a thermostatic, electronic or thermo-electric control, combines different functions in a single component.

The use of dynamic thermostatic valves in combination with thermostatic control heads makes it possible to keep the ambient temperature automatically constant, at the set value, in the room where they are installed, thus guaranteeing effective energy saving.

### Reference documentation

- Tech. broch. 01009 Thermostatic control Series 200
- Tech. broch. 01042 Thermo-electric actuator 656. series.
- Tech. broch. 01242 Thermostatic control 204 series.
- Tech. broch. 01263 Electronic thermal control system Series 210

### Product range

#### VALVES:

##### For steel pipes:

- 230 series Dynamic thermostatic radiator valve, angled version sizes 3/8", 1/2" and 3/4" (\*)
- 231 series Dynamic thermostatic radiator valve, straight version sizes 3/8", 1/2" and 3/4" (\*)
- 234 series Dynamic thermostatic radiator valve, reverse-angled version sizes 3/8", 1/2"

##### For copper, simple plastic and multi-layer pipes:

- 232 series Dynamic thermostatic radiator valve, angled version sizes 3/8", 1/2" radiator x 23 p.1,5 piping
- 233 series Dynamic thermostatic radiator valve, straight version sizes 3/8", 1/2" radiator x 23 p.1,5 piping
- 237 series Dynamic thermostatic radiator valve, reverse-angled version sizes 3/8", 1/2" radiator x 23 p.1,5 piping

#### THERMOSTATIC CONTROL HEADS AND THERMO-ELECTRIC ACTUATORS:

- Code 204000 Thermostatic control head with built-in sensor with liquid-filled element adjustment scale 0-5 corresponding to 7-28°C
- Code 204100 Thermostatic control head with remote sensor liquid-filled element adjustment scale 0-5 corresponding to 7-28°C
- 200 series Thermostatic control head with built-in sensor with liquid-filled element adjustment scale 0-5 corresponding to 7-28°C
- 201 series Thermostatic control head with remote sensor liquid-filled element adjustment scale 0-5 corresponding to 7-28°C
- 202 series Thermostatic control head with built-in sensor with temperature indicator adjustment scale 0-5 corresponding to 7-28°C
- 656. series Thermo-electric actuator

\* 3/4" with tailpiece without rubber seals

#### Technical specifications of valves

##### Material

- Body: brass EN 12165 CW617N, chrome plated
- Obturator control stem: stainless steel
- Hydraulic seals: EPDM
- Control knob: ABS (PANTONE 356C)

##### Performance

- Medium: water, glycol solutions
- Max percentage of glycol: 30%
- Max differential pressure with control fitted: 1.5 bar
- Maximum working pressure: 10 bar
- Nominal Δp control range: (reg. 1-4) 10-150 kPa (reg. 5-6) 15-150 kPa
- Flow rate regulation range: 20-120 l/h
- Thermal medium working temperature range: 5 - 95°C
- Factory pre-setting: position 6

#### Technical specifications of 200/201/202/204 series thermostatic control heads

- Adjustment scale: 0-5
- Adjustment temperature range: 7-28°C
- Frost protection cut-in: 7°C
- Max. ambient temperature: 50°C
- Length of capillary pipe 201 series and code 199100: 2 m
- Room temperature indicator 202 series: 16-26°C

#### Adjustment range of 200/201/202/204 series thermostatic control heads

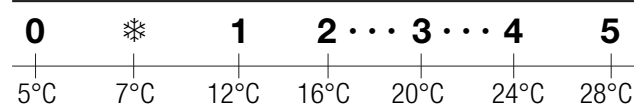

#### Technical specifications of 656. series thermo-electric actuators

- Normally closed
- Electric supply: 230 V (ac) or 24 V (ac)/(dc)
- Power consumption: 3 W
- Protection class: IP 44 (in vertical position)
- Electric supply cable: 80 cm

## Dimensions

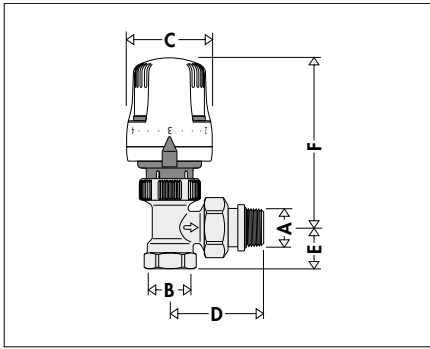

Code	A	B	C	D	E	F
230302 + 200001	3/8"	3/8"	48	48	20	103
230402 + 200001	1/2"	1/2"	48	52.5	23	103
230500 + 200001	3/4"	3/4"	48	62	26	103

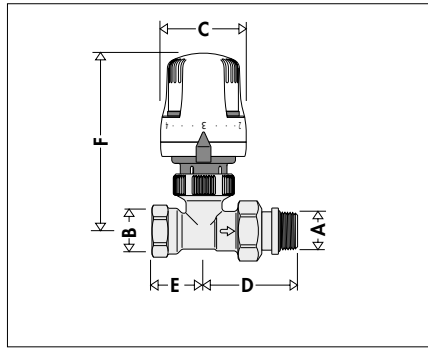

Code	A	B	C	D	E	F
231302 + 200001	3/8"	3/8"	48	48	26	106
231402 + 200001	1/2"	1/2"	48	52.5	29	106
231500 + 200001	3/4"	3/4"	48	62	35	106

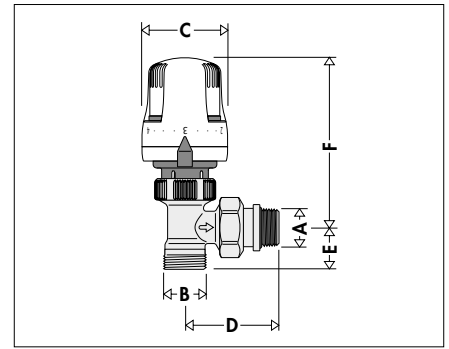

Code	A	B	C	D	E	F
232302 + 200001	3/8"	23 p.1,5	48	48	17.5	103
232402 + 200001	1/2"	23 p.1,5	48	52.5	20.5	103

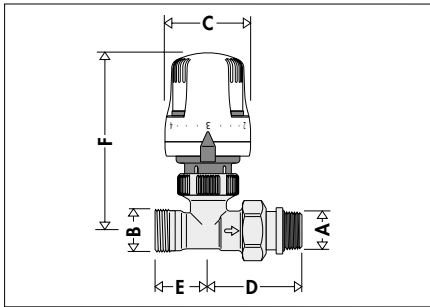

Code	A	B	C	D	E	F
233302 + 200001	3/8"	23 p.1,5	48	48	21	106
233402 + 200001	1/2"	23 p.1,5	48	52.5	24	106

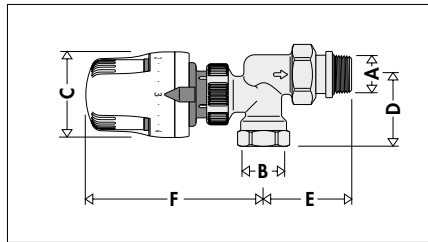

Code	A	B	C	D	E	F
234302 + 200001	3/8"	3/8"	48	40	46	106
234402 + 200001	1/2"	1/2"	48	40	51	106

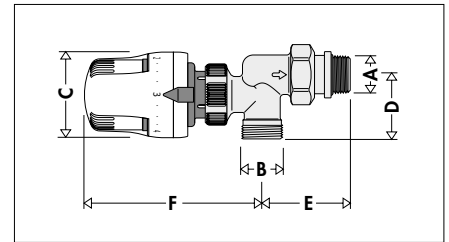

Code	A	B	C	D	E	F
237302 + 200001	3/8"	23 p.1,5	48	37	46	106
237402 + 200001	1/2"	23 p.1,5	48	37	51	106

## Balancing of systems

The hydronic circuits serving air conditioning systems must be balanced, meaning that they must be constructed in such a way as to guarantee the design flow rates of the thermal medium. Depending on the type of system and the appliances installed, and also on the type of control to be implemented, specific balancing devices are required.

### Static balancing

Static-type devices are conventional devices suitable for use in constant flow rate circuits or circuits subject to limited load variations.

With static-type devices, the circuits are difficult to balance perfectly and have operating limitations in the case of partial closure by means of the regulating valves.

**The flow rate in the open circuits does not remain constant at the nominal value.**

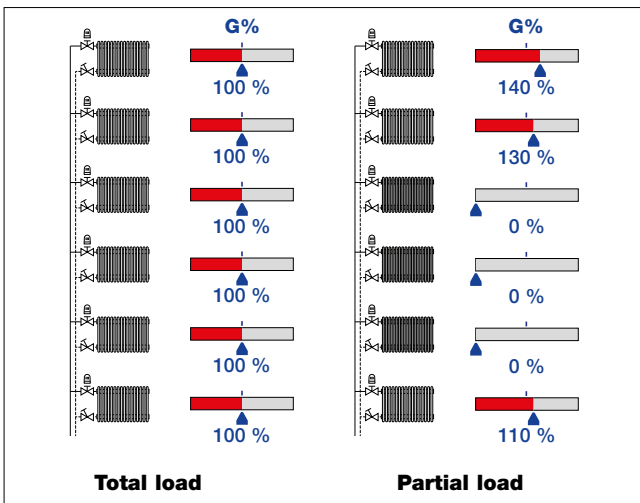
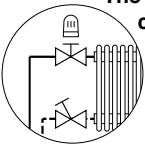

### Dynamic balancing

Dynamic devices are modern automatic devices, mainly suitable for variable flow rate systems with thermal loads that change frequently.

They can balance the hydraulic system automatically, ensuring each terminal receives the design flow rate. Even in the case of partial circuit closure by means of the regulating valves, **the flow rates in the open circuits remain constant at the nominal value.**

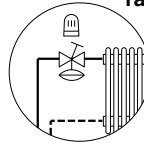

This behaviour is maintained even if there is modulation of the loads; the flow rate value remains constant at the value corresponding to each partial load.

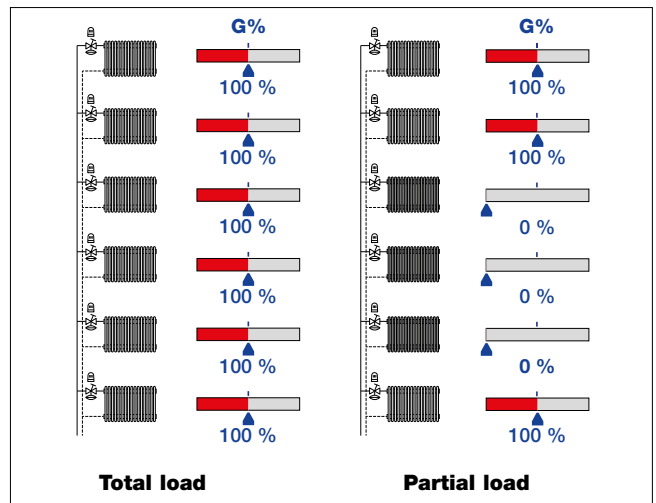

## Operating principle

The dynamic thermostatic valve has been designed with the purpose of controlling a flow rate of thermal medium in the radiators of two-pipe heating systems that is:

- adjustable in accordance with the requirements of the part of the circuit controlled by the device;
- constant despite any variation in differential pressure conditions in the circuit.

The device, in conjunction with a thermostatic control head, combines different functions in a single component:

- Differential pressure regulator**, which automatically cancels the effect of the pressure fluctuations typical of variable flow rate systems and prevents noisy operation.
- Device for pre-setting flow rate**, which allows direct setting of the maximum flow rate value, thanks to the combination with the differential pressure regulator.
- Flow rate control depending on the ambient temperature**, thanks to the combination with a thermostatic control head. The flow rate control is optimised because it is pressure-independent.

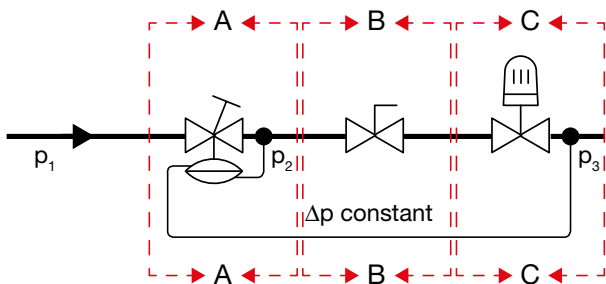

Where:

- $p_1$  = upstream pressure
- $p_2$  = intermediate pressure
- $p_3$  = downstream pressure
- $(p_1 - p_3)$  = total valve  $\Delta p$
- $(p_2 - p_3)$  = constant  $\Delta p$

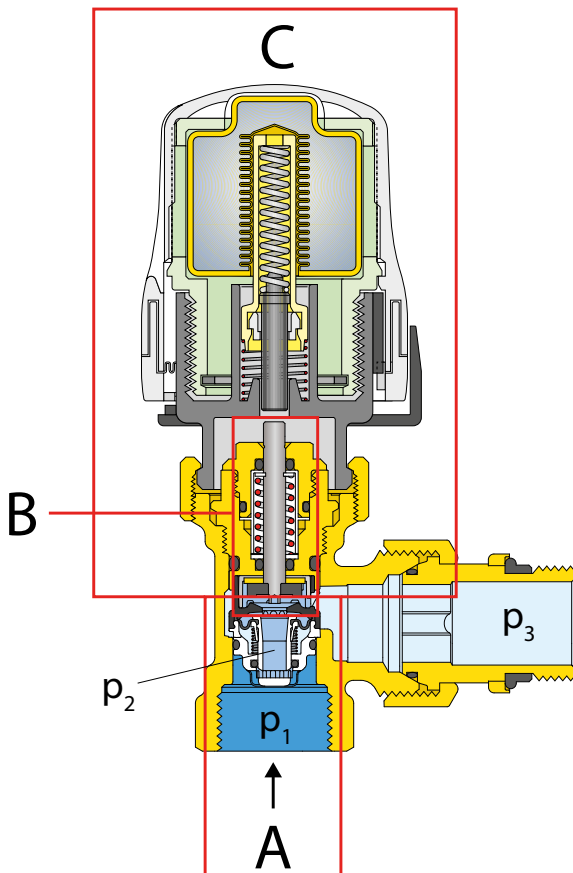

Device (A) regulates the  $\Delta p$  and keeps it constant across the device (B+C), by means of an automatic action (balancing between the force generated by the differential pressure and the internal opposing spring). If  $(p_1 - p_3)$  increases, the internal  $\Delta p$  regulator reacts to close the bore and maintains  $\Delta p$  constant; in these conditions the flow rate will remain constant.

Device (B) regulates flow rate  $G$  by changing its bore cross section. The change in bore cross section determines the hydraulic coefficient value ( $K_v$ ) of the regulator device (B), which remains constantly at:

- a manually pre-set value
- a value determined by the actuator's regulating action.

## Working range

For the device to keep the flow rate constant independently from the circuit's differential pressure conditions, the total valve  $\Delta p$  ( $p_1 - p_3$ ) must be in the range between the minimum  $\Delta p$  value (10 kPa for adjustments from 1 to 4 and 15 kPa for adjustments 5 and 6) and the maximum value of 150 kPa.

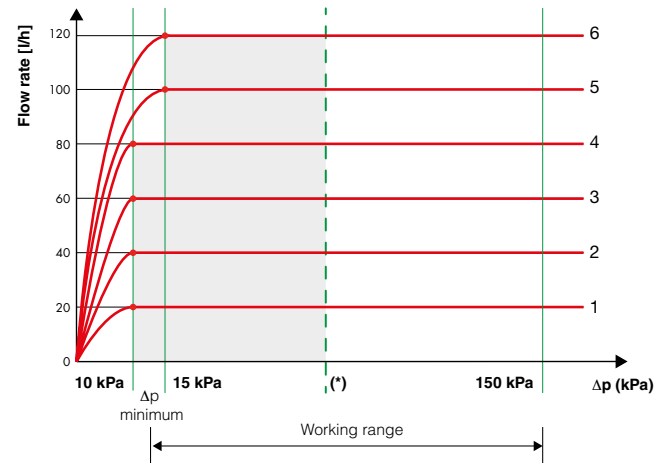

(\*) Recommended working range: for the best dynamic behaviour without problems linked to the passage of the water flow through the valve it is recommended to work with  $\Delta p < 70$  kPa.

- $\Delta p$  min (20÷80 l/h): 10 kPa
- $\Delta p$  min (100-120 l/h): 15 kPa

## Flow rate accuracy

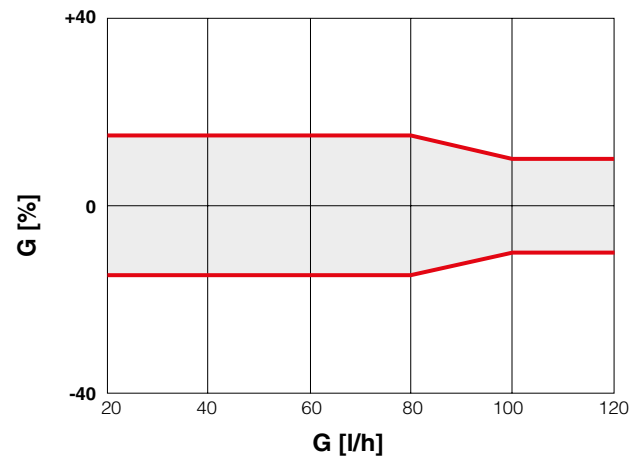

- $\Delta p$  min (20–80 l/h): 10 kPa
- $\Delta p$  min (100–120 l/h): 15 kPa

## Construction details

### Compact device

The dynamic valve has been designed with dimensions compatible with those of traditional valves, therefore in case of requalification, no special adaptations are required.

**IMPORTANT! The dynamic valve headwork cannot be installed in a traditional valve.**

### Headwork replacement

The headwork, preassembled in a single body, contains all the regulating components. It can be inspected for cleaning or replacement if necessary using the special headwork replacement kit (code 387201), without any need to remove the radiator valve from the pipe.

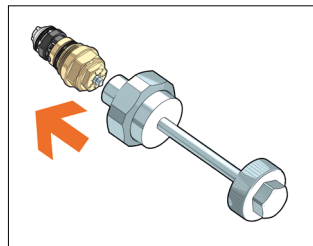
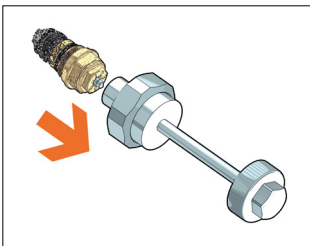
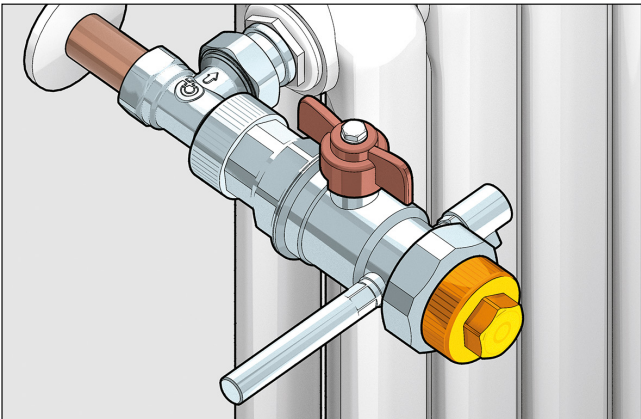

## Valve

The stainless steel control stem (1) has a double EPDM O-Ring seal.

The EPDM obturator (2) is made so as to optimise the hydraulic characteristics of the valve during the progressive action of opening or closing in thermostatic operation.

The internal pre-setting device (3) is made of anti-seizing polymer. The balancing membrane (4) made of EPDM with high mechanical sensitivity combined with the spring and with the control device allows adjustment of the differential pressure.

There is a protective casing (5) to minimise the risk of dirt getting into the dynamic component.

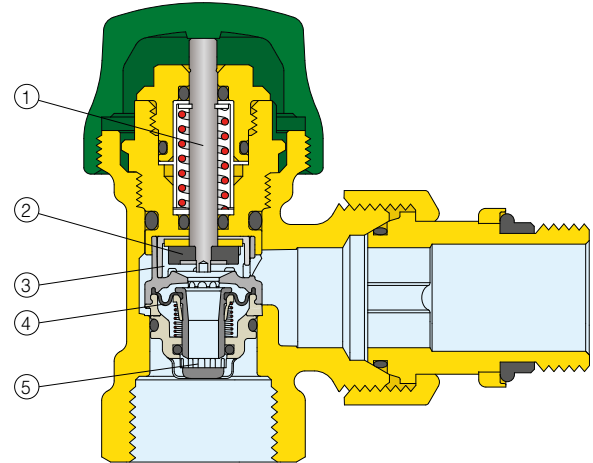

### Ease of design

The presence of the internal device which is able to regulate the flow rate and stabilise the working  $\Delta p$  allows faster design and balancing operations: no support components are required for calculations and pre-setting is very simple.

## Hydraulic characteristics

### Without thermostatic control head

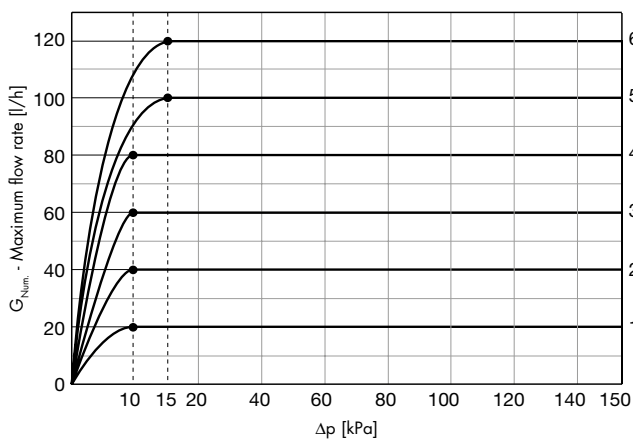

### With thermostatic control head and 2K proportional band

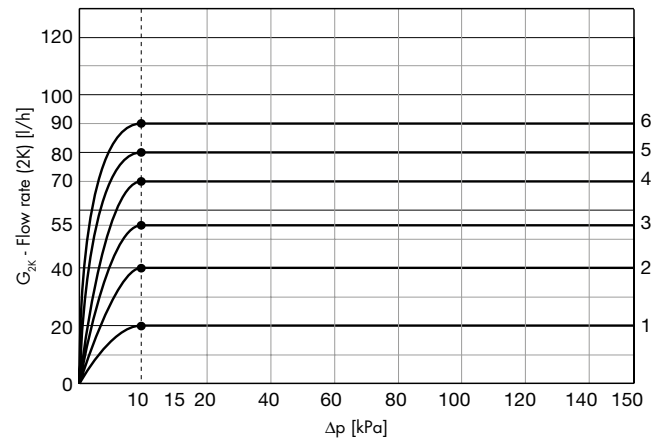

	Pre-setting position					
	1	2	3	4	5	6
G <sub>Num.</sub> (l/h)	20	40	60	80	100	120
G <sub>2K</sub> (l/h)	20	40	55	70	80	90

### System sizing

For correct system sizing, the valves are normally selected by determining the pre-setting value based on the design flow rate on the diagram with thermostatic control head and 2K proportional band.

Stepped adjustment, not continuous.

## Example of pre-setting using angled 1/2" dynamic thermostatic valves

Let us suppose we have to balance three circuits having the following characteristics:

Design power	Circuit 1	$Q_1 = 1800 \text{ kcal/h}$
	Circuit 2	$Q_2 = 750 \text{ kcal/h}$
	Circuit 3	$Q_3 = 1600 \text{ kcal/h}$
Design temperature difference		$\Delta T = 20$

### Design flow rate

The design flow rate for each radiator is calculated with the equation:

$$G = Q/\Delta T$$

Circuit 1	$G_1 = 90 \text{ l/h}$
Circuit 2	$G_2 = 37,5 \text{ l/h}$
Circuit 3	$G_3 = 80 \text{ l/h}$

### Pre-setting and effective flow rate

The setting positions can be easily determined based on the design flow rates from the graph or from the table shown in the paragraph "Hydraulic characteristics" (considering 2K adjustment for sizing).

Circuit 1	<b>pos. 6</b>	$G_1 = 90 \text{ l/h}$
Circuit 2	<b>pos. 2</b>	$G_2 = 40 \text{ l/h}$
Circuit 3	<b>pos. 5</b>	$G_3 = 80 \text{ l/h}$

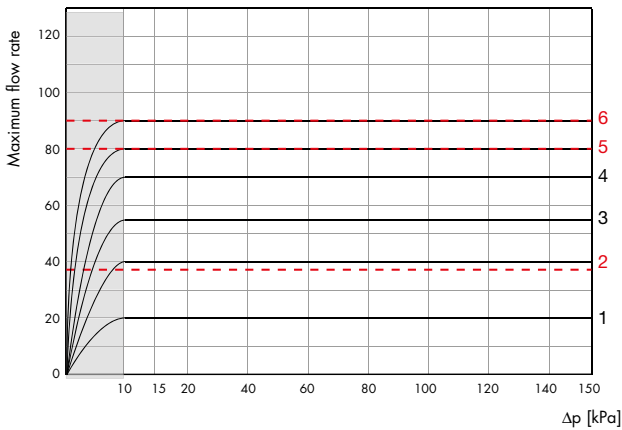

### Minimum operating Δp: on site check of the disadvantaged circuit

The dynamic thermostatic valve, with 2K adjustment, works between 10 kPa and 150 kPa. For this reason it is necessary to identify the most disadvantaged circuit and determine the available Δp using the Δp measuring kit code 230100. (See accessories) and ensure the minimum operating Δp to this circuit, adjusting the circulation pump head.

### Minimum operating Δp: calculation of disadvantaged circuit

The most disadvantaged circuit, to which ensure the minimum operating Δp can be identified through the rigorous calculation of the head losses.

1 - Calculation of the head losses of every single radiator circuit ( $\Delta p_C$ )

$$\Delta p_C = \Delta p_{\min} + \Delta p_{T/R}$$

where:

$\Delta p_{\min}$  minimum working Δp of the DYNAMICAL® valve

$\Delta p_{T/R}$  head losses in the pipes / radiator. (\*)

Consequently:

	Circuit 1	Circuit 2	Circuit 3
$\Delta p_{\min}$	10 kPa	10 kPa	10 kPa
$\Delta p_{T/R}$ (*)	2,5 kPa	3 kPa	2 kPa
$\Delta p_C$	12,5 kPa	13 kPa	12 kPa

2 - Calculation of the head losses of the connecting sections ( $\Delta p_{TC}$ ). (\*)

	Section 0-1	Section 1-2	Section 2-3
$\Delta p_{TC}$	4 kPa	2 kPa	1,5 kPa

(\*) In the case in the example, for the sake of simplicity the values are assumed to be known without giving the whole calculation.

3 - Calculation of the total head losses of each circuit with respect to the circulator. ( $\Delta p_{TOT}$ ).

$$\begin{aligned} \text{Circ. 1 } \Delta p_{TOT 1} &= \Delta p_{TC 0-1} + \Delta p_{C1} \\ &= 4 + 12,5 \\ &= 16,5 \text{ kPa} \end{aligned}$$

$$\begin{aligned} \text{Circ. 2 } \Delta p_{TOT 2} &= \Delta p_{TC 0-1} + \Delta p_{TC 1-2} + \Delta p_{C2} \\ &= 4 + 2 + 13 \\ &= 19 \text{ kPa} \end{aligned}$$

$$\begin{aligned} \text{Circ. 3 } \Delta p_{TOT 3} &= \Delta p_{TC 0-1} + \Delta p_{TC 1-2} + \Delta p_{TC 2-3} + \Delta p_{C3} \\ &= 4 + 2 + 1,5 + 12 \\ &= 19,5 \text{ kPa} \end{aligned}$$

In the case in the example, the most disadvantaged circuit is number 3, which corresponds to the maximum total head loss.

### Determining the circulation pump flow rate

The flow rate of the circulation pump is calculated, with sufficient accuracy, as the sum of the  $G_{\max}$  flow rates of the radiators (a). Therefore:

$$G_{\text{pump}} = \Sigma G_{\max}$$

In a theoretically more accurate way, the flow rate can also be calculated as the sum of the flow rates at which the DYNAMICAL® valves are set (b).

In the previous example:

$$(a) \quad \Sigma G_{\max} = 207,5 \text{ l/h}$$

$$(b) \quad \text{pos. 6} + \text{pos. 2} + \text{pos. 5} = 90 + 40 + 80 = 210 \text{ l/h}$$

the differences involved between the two methods are not very high.

### Determining the circulation pump head

The head of the circulation pump is calculated as the sum of the head losses of the most disadvantaged circuit.

$\Delta p_{\text{Disadvantaged C}}$  (including the working  $\Delta p_{\min}$  of the DYNAMICAL® valve and the pipe/radiator losses  $\Delta p_{T/R}$ ) and the Δp of the sections connecting that circuit to the circulation pump.

Therefore:

$$\Delta p_{\text{pump}} = \Delta p_{\min} + \Delta p_{T/R \text{ disadvantaged}} + \Sigma \Delta p_{\text{connecting sections}}$$

In the case in the example:

$$\Delta p_{\text{pump}} = \Delta p_{TOT3}$$

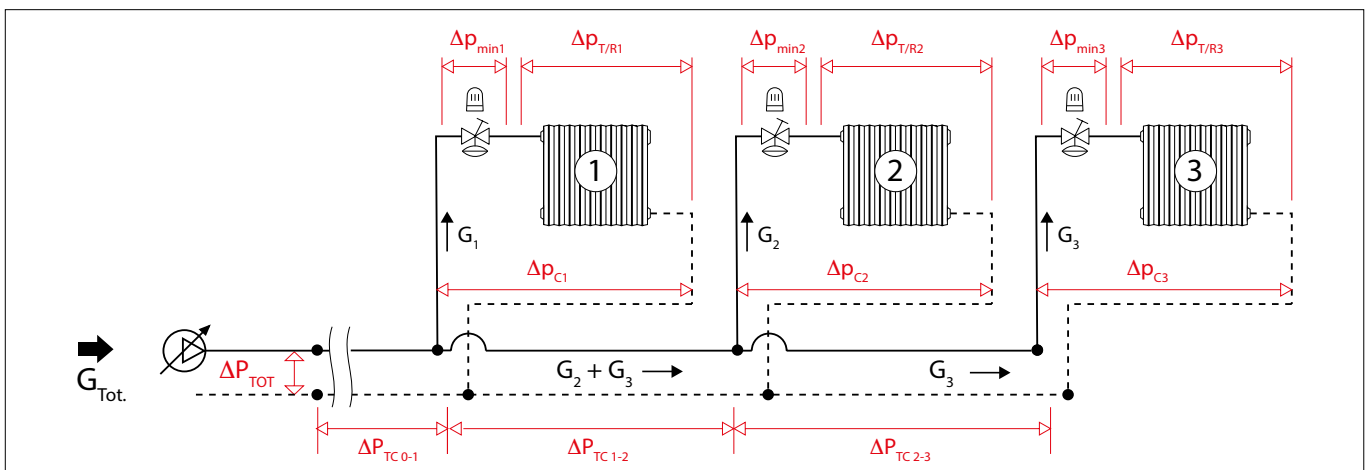

**Pre-setting and installation of thermostatic heads, electronic or thermo-electric actuators**

Remove the knob from the valve.

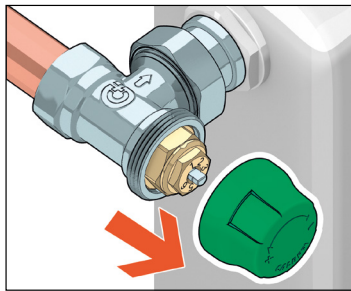

To pre-set the flow rate, position the appropriate shaped nut. The reference of the setting position is defined by the orientation of the flat side surface (1) of the control stem.

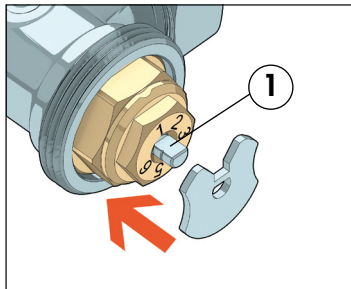

Rotate the control stem to select the desired position.

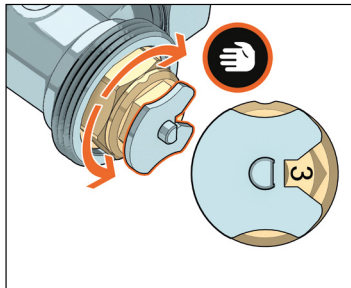

Remove the adjustment nut.

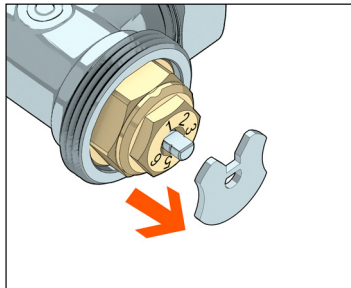

Install the thermostatic (2), electronic (3) or thermo-electric (4) actuators on the valve.

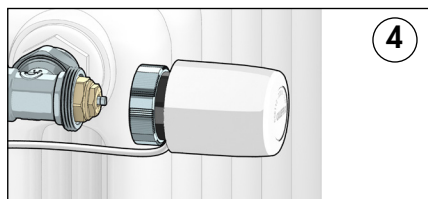
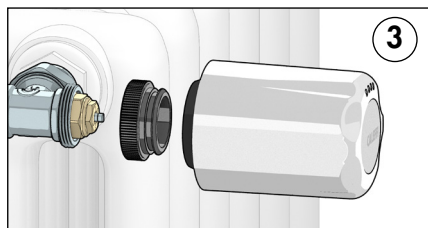
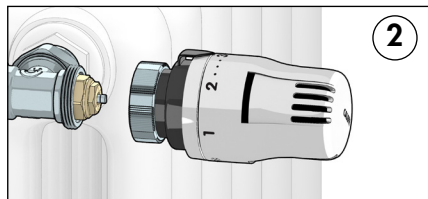

**Installation of valves with thermostatic control heads**

The thermostatic control heads must be installed in horizontal position.

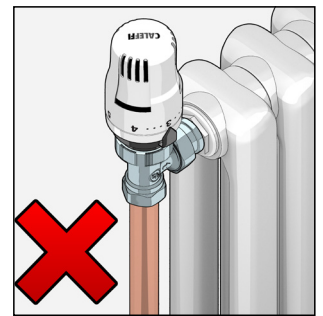
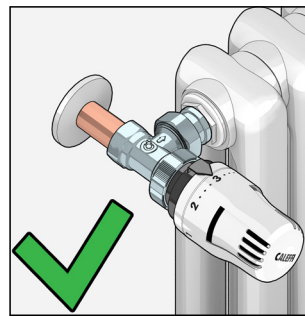

The sensitive element of the thermostatic control heads must never be installed in niches, radiator cabinets, behind curtains or exposed to direct sunlight, otherwise it may produce false readings.

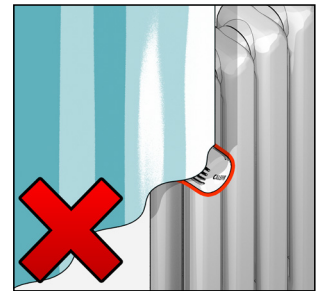
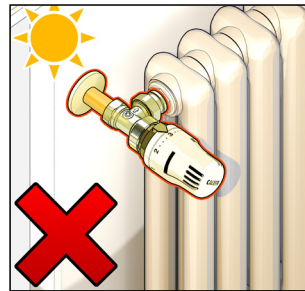

**Operating principle of thermostatic control head**

The control device of the thermostatic valve is a proportional temperature regulator, composed of a bellows containing a specific thermostatic liquid. As the temperature increases, the liquid increases in volume and causes the bellows to expand. As the temperature decreases, the inverse process occurs; the bellows contracts due to the thrust of the counter-spring. The axial movements of the sensor element are transmitted to the valve actuator by means of the connecting stem, thereby adjusting the flow of medium in the heat emitter.

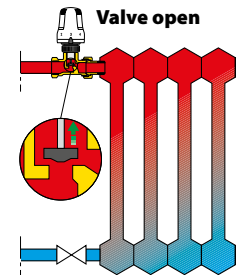
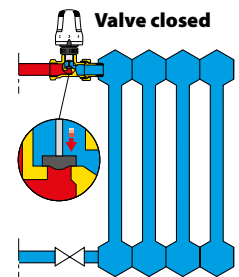

**Combination with heat metering systems**

The thermostatic valves can be used in combination with metering systems. In this way, the actual consumption of each radiator can be monitored in order to contain system running costs which, in centralised systems, can be shared in such a way to be advantageous to the end users.

**Application diagrams**

**System with risers with dynamic thermostatic valves and thermostatic control heads.**

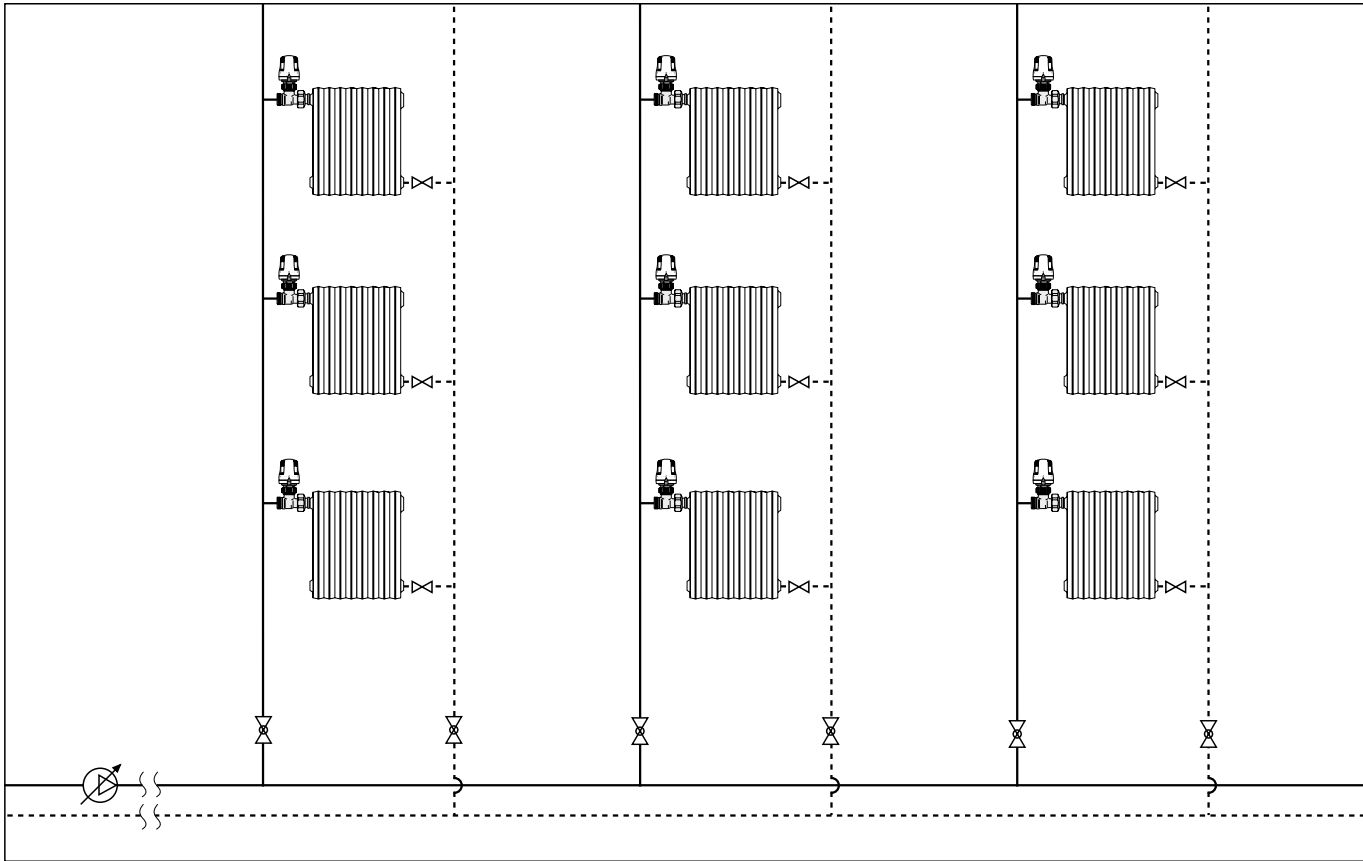

**Independent zone system with dynamic thermostatic valves with thermostatic control heads and variable speed circulator**

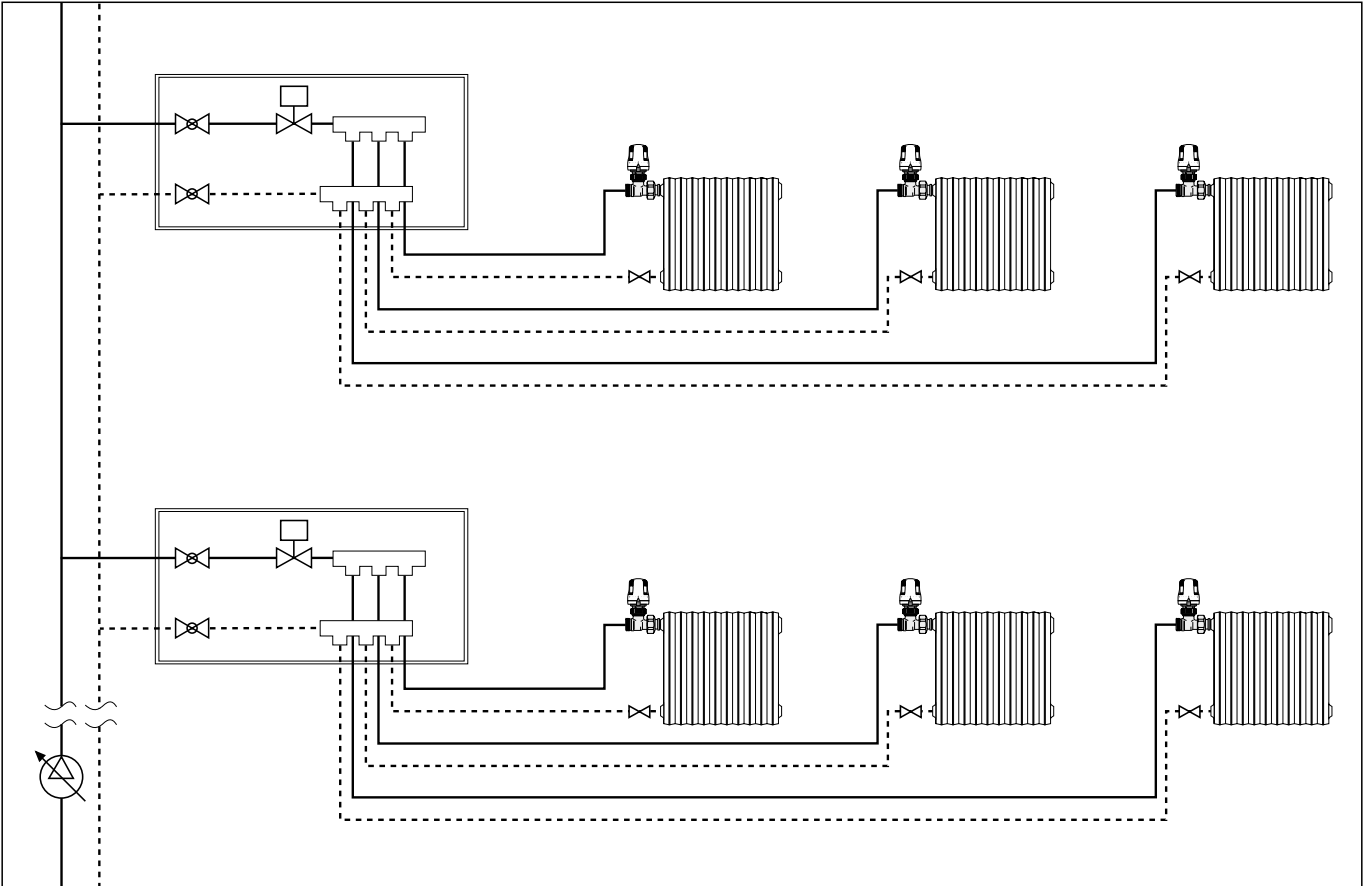

## Accessories

### 230

Kit for measuring  $\Delta p$  in the circuits with dynamic valves.



Code

230100

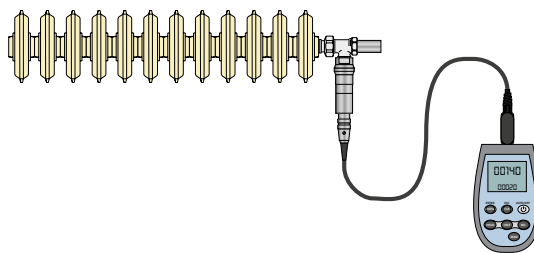

To use the instrument, the headwork replacement kit is necessary (code 387201), which allows you to extract the headwork of the dynamic thermostatic radiator valve and to insert the appropriate headwork for the measuring instrument.

## SPECIFICATION SUMMARIES

### 230 series

Dynamic thermostatic radiator valve fitted for thermostatic control heads, electronic and thermo-electric actuators. Angled connections for steel pipe. Connection to the radiator 3/8" or 1/2" M with tailpiece supplied with EPDM seal, 3/4" with tailpiece without seal. Brass body. Chrome plated. Knob in ABS green PANTONE 356C, for manual control. Stainless steel control stem. Double seal on control stem with EPDM O-Ring. Medium working temperature range 5–95°C. Maximum working pressure 10 bar. PCT - INTERNATIONAL APPLICATION PENDING.

### 231 series

Dynamic thermostatic radiator valve fitted for thermostatic control heads, electronic and thermo-electric actuators. Straight connections for steel pipe. Connection to the radiator 3/8" or 1/2" M with tailpiece supplied with EPDM seal, 3/4" with tailpiece without seal. Brass body. Chrome plated. Green PANTONE 356C ABS knob for manual control. Stainless steel control stem. Double seal on control stem with EPDM O-Ring. Medium working temperature range 5–95°C. Maximum working pressure 10 bar. PCT - INTERNATIONAL APPLICATION PENDING.

### 232 series

Dynamic thermostatic radiator valve fitted for thermostatic control heads, electronic and thermo-electric actuators. Angled connections for copper, plastic and multilayer pipes 23 p.1,5 for pipes from 10 to 18 mm. Connection to radiator 3/8" and 1/2" M with tailpiece equipped with EPDM seal. Brass body. Chrome plated. Knob in ABS green PANTONE 356C, for manual control. Stainless steel control stem. Double seal on control stem with EPDM O-Ring. Medium working temperature range 5–95°C. Maximum working pressure 10 bar. PCT - INTERNATIONAL APPLICATION PENDING.

### 233 series

Dynamic thermostatic radiator valve fitted for thermostatic control heads, electronic and thermo-electric actuators. Straight connections for copper, plastic and multilayer pipes 23 p.1,5 for pipes from 10 to 18 mm. Connection to radiator 3/8" and 1/2" M with tailpiece equipped with EPDM seal. Brass body. Chrome plated. Knob in ABS green PANTONE 356C, for manual control. Stainless steel control stem. Double seal on control stem with EPDM O-Ring. Medium working temperature range 5–95°C. Maximum working pressure 10 bar. PCT - INTERNATIONAL APPLICATION PENDING.

### 234 series

Reverse-angled dynamic thermostatic radiator valve fitted for thermostatic control heads, electronic and thermo-electric actuators. For steel pipes. Connection to radiator 3/8" and 1/2" M with tailpiece equipped with EPDM seal. Brass body. Chrome plated. Knob in ABS green PANTONE 356C, for manual control. Stainless steel control stem. Double seal on control stem with EPDM O-Ring. Medium working temperature range 5–95°C. Maximum working pressure 10 bar. PCT - INTERNATIONAL APPLICATION PENDING.

### 237 series

Reverse-angled dynamic thermostatic radiator valve fitted for thermostatic control heads, electronic and thermo-electric actuators. For copper, simple plastic and multilayer pipes 23 p.1,5 for pipes from 10 to 18 mm. Connection to radiator 3/8" and 1/2" M with tailpiece equipped with EPDM seal. Brass body. Chrome plated. Knob in ABS green PANTONE 356C, for manual control. Stainless steel control stem. Double seal on control stem with EPDM O-Ring. Medium working temperature range 5–95°C. Maximum working pressure 10 bar. PCT - INTERNATIONAL APPLICATION PENDING.

We reserve the right to make changes and improvements to the products and related data in this publication, at any time and without prior notice.