

Anti-scale adjustable thermostatic mixing valves



521 series



01050/21 EN

Replaces 01050/11 GB



Function

The thermostatic mixing valve is used in systems that produce domestic hot water. It is designed to maintain the preset temperature of the mixed water delivered to the user outlet, when there are variations in the temperature and pressure of the hot and cold water at the inlet, or in the drawn-off flow rate. These devices are also available with fittings complete with strainers and check valves on the hot and cold water inlets.



Product range

Code 521400/500 Thermostatic mixing valve sizes DN 20 (1/2") and DN 20 (3/4")
 Code 521503 Thermostatic mixing valve with check valves at the inlet size DN 20 (3/4")
 Code 521115/122 Thermostatic mixing valve with check valves and strainers at the inlet sizes DN 20 (Ø15 mm) and DN 20 (Ø22 mm) for copper pipe

Technical specifications

Materials: - body: dezincification resistant alloy **CR** EN 12165 CW724R, chrome plated
 - obturator: PPO
 - springs: stainless steel EN 10270-3 (AISI 302)
 - seal elements: EPDM

Adjustment temperature range: 30–65 °C
 Accuracy: ± 2 °C

Max. working pressure (static): 14 bar
 Max. working pressure (dynamic): 5 bar
 Max. inlet temperature: 85 °C

Max. inlet pressure ratio (H/C or C/H): 2:1
 Minimum temperature difference between inlet hot water and outlet mixed water to ensure optimal performance: 15 °C
 Minimum flow rate to ensure optimal performance: 5 l/min
 Connections: 1/2" and 3/4" M (ISO 228-1) with union Ø 15 and Ø 22 with nut

Dimensions

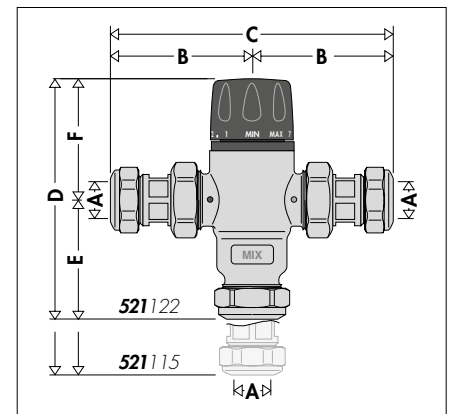
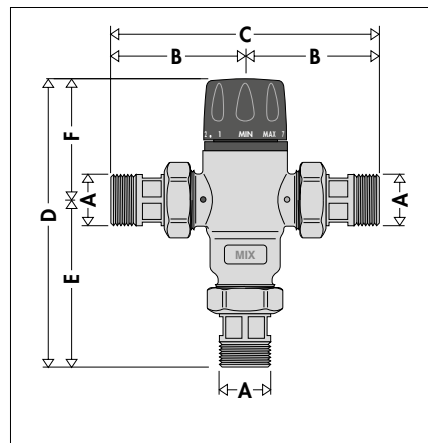
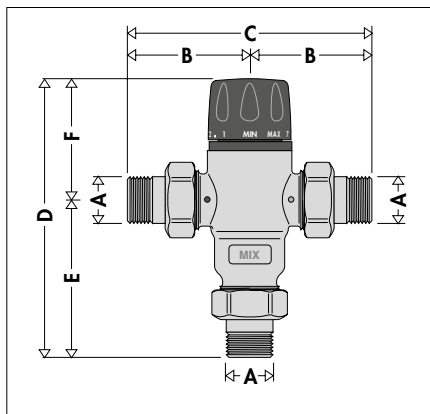

Code	DN	A	B	C	D	E	F	Mass (kg)
521400	20	1/2"	67	134	152	86,5	65,5	1,11
521500	20	3/4"	67	134	152	86,5	65,5	1,12

Code	DN	A	B	C	D	E	F	Mass (kg)
521503	20	3/4"	71,5	143	156,5	91	65,5	1,21

Code	DN	A	B	C	D	E	F	Mass (kg)
521115	20	Ø 15	79	158	163,5	98	65,5	1,30
521122	20	Ø 22	80,5	161	132	66,5	65,5	1,42

Legionella - scalding risk

In systems producing domestic hot water with storage, in order to prevent the dangerous infection known as Legionnaire's disease, the hot water must be stored at a temperature of at least 60 °C. At this temperature it is certain that the growth of the bacteria causing this infection will be completely prevented.

At this temperature, however, the water cannot be used directly.

As shown in the diagram opposite, temperatures over 50 °C can cause burns very quickly.

For example, at 55 °C, partial burn occurs in about 30 seconds, whereas at 60 °C partial burn occurs in about 5 seconds. On average, these times can be halved for children and elderly people.

It is therefore necessary to use a thermostatic mixing valve able to:

- reduce the temperature at the point of use to a value lower than that of the storage and make it suitable for domestic use.
For safety reasons, it is recommended to set the temperature of the mixed water sent to the user outlet to values no higher than 50 °C.
- keep the temperature constant in spite of variations in the pressure and temperature at the inlet.

Energy saving

Energy savings are governed in Italy by Presidential Decree no. 412/93 making it compulsory to use mixing valves on domestic water systems with storage, to limit the temperature of the water at the inlet of the delivery network to 48 °C with a tolerance of +5 °C.

The purpose of limiting the temperature is to reduce passive thermal losses through the delivery network as much as possible, besides preventing the delivery of water at a higher temperature than necessary.

Operating principle

The regulating element in the thermostatic mixing valve consists of a temperature sensor fully immersed in the mixed water outlet pipe which, by expanding and contracting, continuously ensures correct proportioning of hot and cold water at the inlet.

The water proportions are regulated by a piston that slides inside a special cylinder placed between the hot and cold water passage channels.

Even if the pressure drops due to hot or cold water drawn-off by other users or temperature variations at the inlet, the mixing valve automatically adjusts the water flow rate until the set temperature is achieved.

Construction details

Anti-scale materials

The materials used in constructing the mixing valve were selected to eliminate seizing due to limescale deposits. All functional parts, such as the obturator, valve seats and guides, are made using a special anti-scale material with low friction coefficient, which ensures that performance is maintained over time.

Temperature adjustment and locking

The control knob is used to adjust the temperature in a full turn (360°) between min. and max. It also has tamper protection for locking the temperature at the set value.

Thermal disinfection

The adjacent diagram shows the behaviour of Legionella Pneumophila bacteria as the temperature conditions of the water containing the bacteria vary.

To ensure correct thermal disinfection, it is necessary to go up to values of no less than 60 °C.

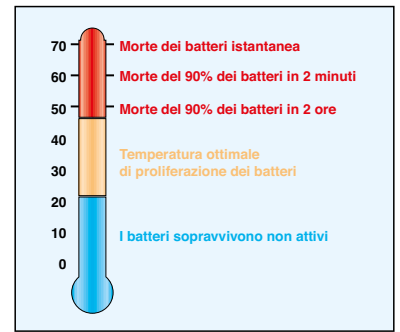

Temperature - Exposure time

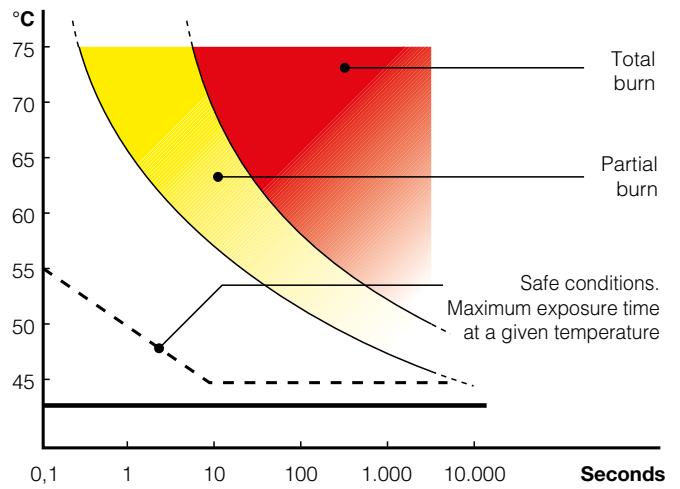

Code 521400/500

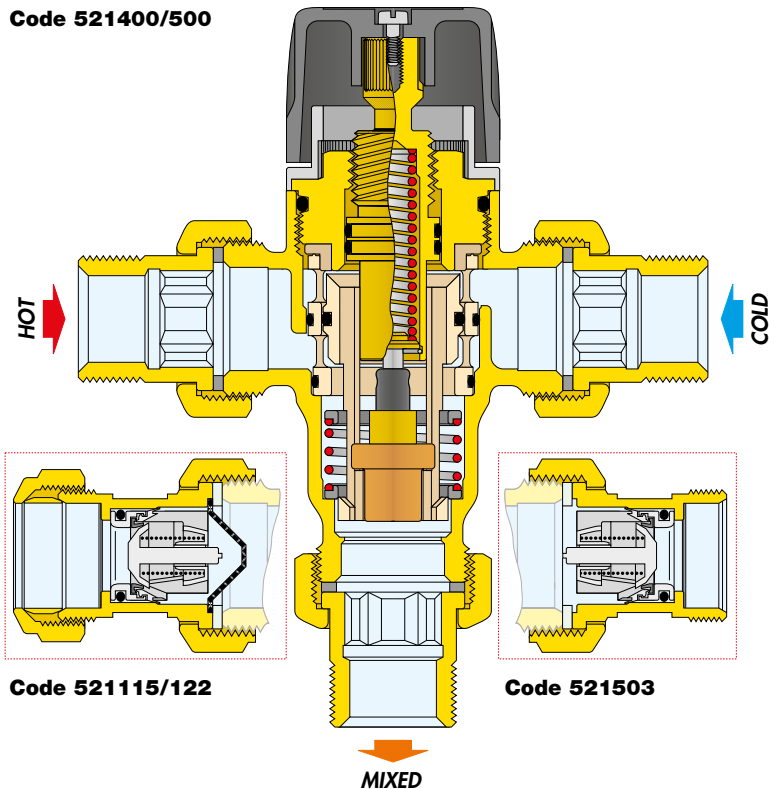

Hydraulic characteristics

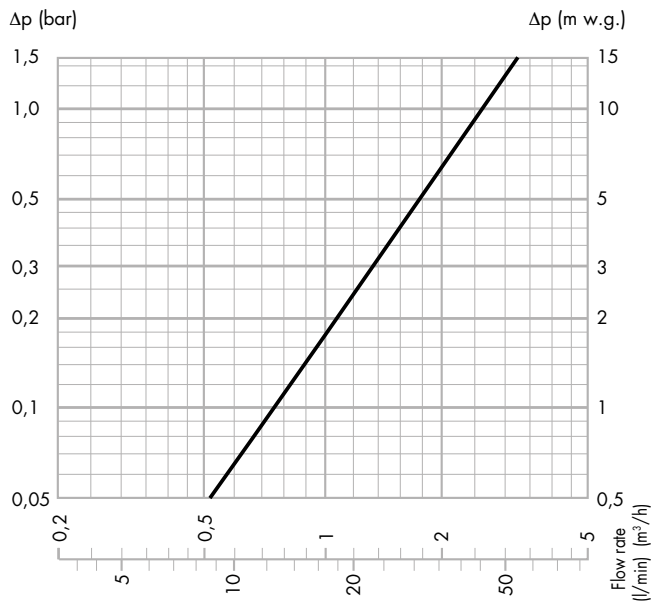

$K_v = 2,6 \text{ (m}^3/\text{h)}$

Application

Given their flow characteristics, Caleffi 521 series thermostatic mixing valves can be installed to control water temperature for single user outlets (e.g. washbasins, bidets, showers) and for multiple user outlets.

Caution: If the anti-scald function is required, use Caleffi 5213 series mixing valves which offer high thermal performance.

To ensure that the mixed water is supplied at a stable temperature, a minimum flow rate of 5 l/min must be guaranteed to the thermostatic mixing valves.

Temperature stability

The diagram below indicates the stability of the mixed water temperature as the temperature of the water within the storage fluctuates.

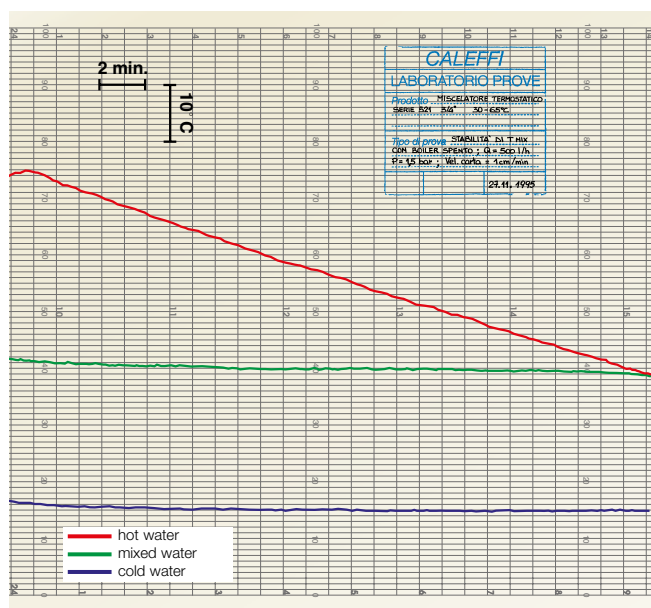

Instant hot water production

Caleffi 521 series thermostatic mixing valves **must not be** coupled to boilers with instantaneous domestic hot water production. Their installation would impair boiler operation.

Installation

Before installing the mixing valve, the connecting pipes should be flushed to remove any impurities that could impair performance. It is recommended to always install strainers of adequate performance at the water inlet from the water supply network.

The thermostatic mixing valves codes 521115/521122 are equipped with strainers at the hot and cold water inlets.

The 521 series thermostatic mixing valves must be installed according to the diagrams shown in the instruction sheet or in this leaflet.

The 521 series thermostatic mixing valves can be installed in any position, horizontally or vertically.

The following marks are indicated on the valve body:

- hot water inlet, indicated by a red colour and the word "HOT"
- cold water inlet, indicated by a blue colour and the word "COLD"
- mixed water outlet, indicated by the word "MIX".

Check valves

In systems with thermostatic mixing valves, check valves must be installed to prevent undesired backflow.

The thermostatic mixing valves codes 521503 and 521115/22 equipped with check valves at the hot and cold water inlets.

Commissioning

In view of the special purpose of the thermostatic mixing valve, it must be commissioned in accordance with current regulations by qualified personnel, using appropriate temperature measurement equipment. We recommend using a digital temperature gauge for measuring the mixed water temperature.

Temperature adjustment

The temperature is set at the desired value using the control knob with the graduated scale on the valve.

Temperature adjustment table

Position	Min	1	2	3	4	5	6	7	Max
T (°C)	27	32	38	44	49	53	58	63	67

Reference values: $T_{hot} = 68 \text{ }^\circ\text{C}$
 $T_{cold} = 13 \text{ }^\circ\text{C}$
 Hot and cold water inlet pressures = 3 bar

Locking the set value

After adjusting the temperature, the setting can be locked at the desired value using the control knob.

For this purpose, unscrew the locking screw at the top of the control knob, remove the knob and then put it back on so that the internal reference couples with the protrusion on the knob holder nut.

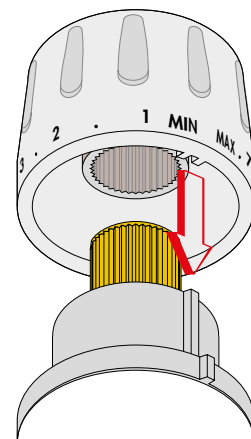

Application diagrams

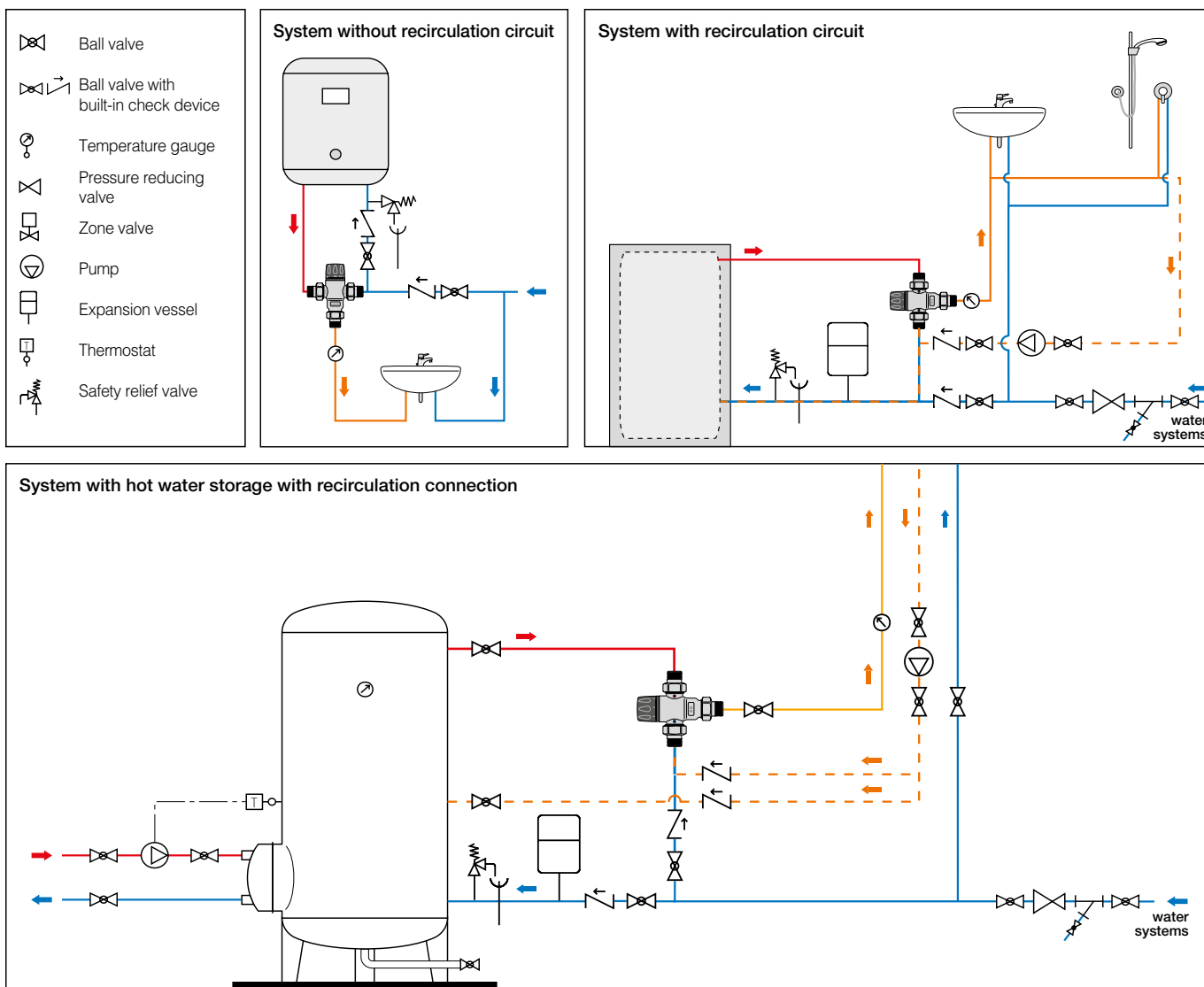

SPECIFICATION SUMMARY

Code 521.00

Adjustable thermostatic mixing valve. Size DN 20. Connections 1/2" (or 3/4") M (ISO 228-1) with union. Dezincification resistant alloy body. Chrome plated. Obturator, regulation seats and slide surfaces in anti-scale plastic material. EPDM seals. Stainless steel spring. Maximum working temperature 85 °C. Adjustment temperature range 30 °C to 65 °C. Maximum working pressure 14 bar. Accuracy ± 2 °C. Equipped with tamper-proof temperature setting lock.

Code 521503

Adjustable thermostatic mixing valve. Size DN 20. Connections 3/4" M (ISO 228-1) with union. Dezincification resistant alloy body. Chrome plated. Obturator, regulation seats and slide surfaces in anti-scale plastic material. EPDM seals. Stainless steel spring. Maximum working temperature 85 °C. Adjustment temperature range 30 °C to 65 °C. Maximum working pressure 14 bar. Accuracy ± 2 °C. Equipped with check valves at the hot and cold water inlets. Equipped with tamper-proof temperature setting lock.

Code 521115/22

Adjustable thermostatic mixing valve. Size DN 20. Connections $\varnothing 15$ (or $\varnothing 22$) copper pipe. Dezincification resistant alloy body. Chrome plated. Obturator, regulation seats and slide surfaces in anti-scale plastic material. EPDM seals. Stainless steel spring. Maximum working temperature 85 °C. Adjustment temperature range 30 °C to 65 °C. Maximum working pressure 14 bar. Accuracy ± 2 °C. Equipped with check valves and strainers at the hot and cold water inlets. Equipped with tamper-proof temperature setting lock.

We reserve the right to make changes and improvements to our products and the related technical data in this publication, at any time and without prior notice. The website www.caleffi.com always has the most up-to-date version of the document, which should be used for technical verifications.