

EUROSMART
DESIGN + ENGINEERING
GROHE GERMANY

99.0251.031/ÄM 230692/07.14

www.grohe.com

Pure Freude an Wasser



33 555

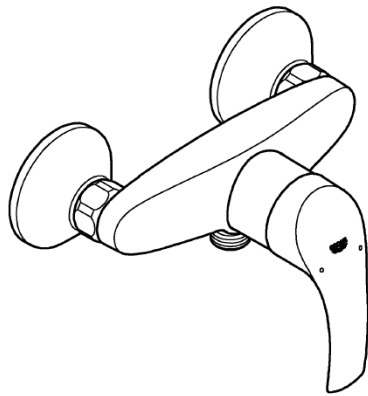

33 302

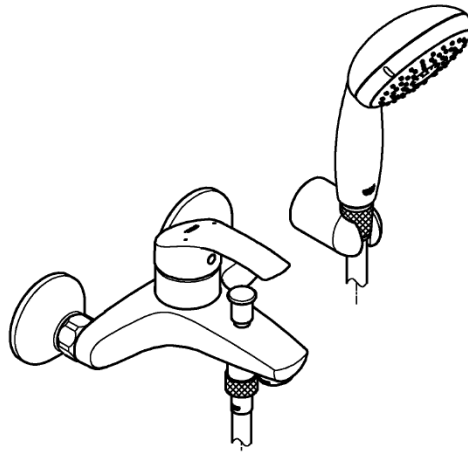

23 460

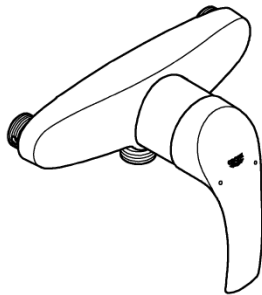

23 461

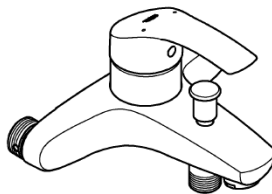

33 300

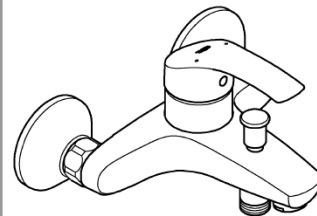

- | | | | | | |
|------------------|-------------------|-------------------|------------------|--------------------|-------------------|
| D1 | NL3 | PL6 | P8 | BG11 | CN13 |
| GB1 | S4 | UAE6 | TR9 | EST11 | UA14 |
| F2 | DK4 | GR7 | SK9 | LV12 | RUS ... 14 |
| E2 | N5 | CZ7 | SLO ...10 | LT12 | |
| I3 | FIN5 | H8 | HR ...10 | RO13 | |

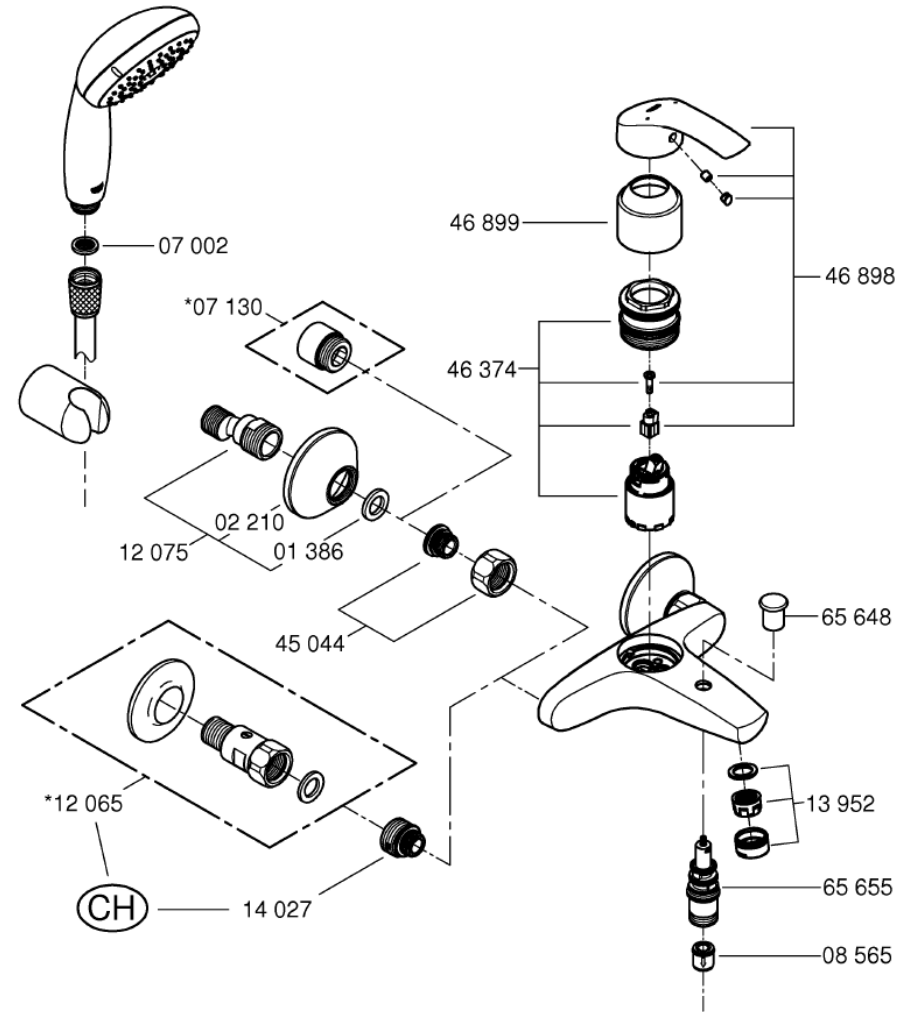
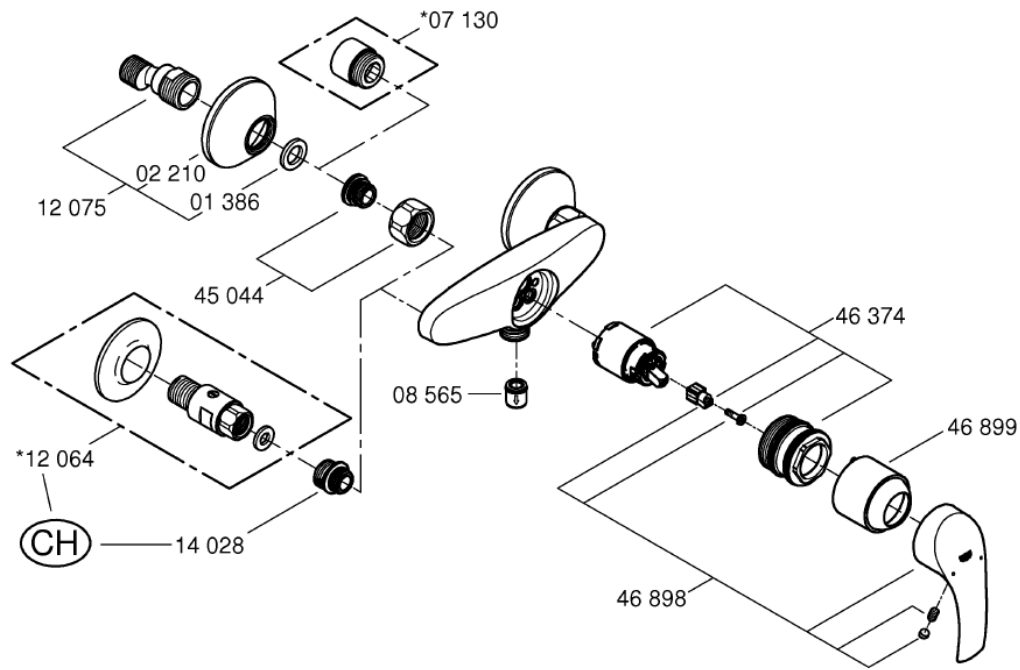

33 555

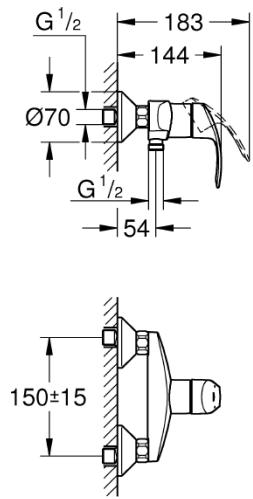

33 302

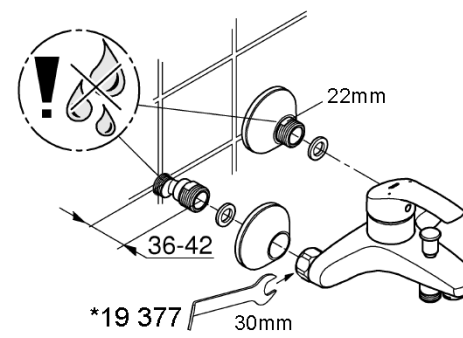
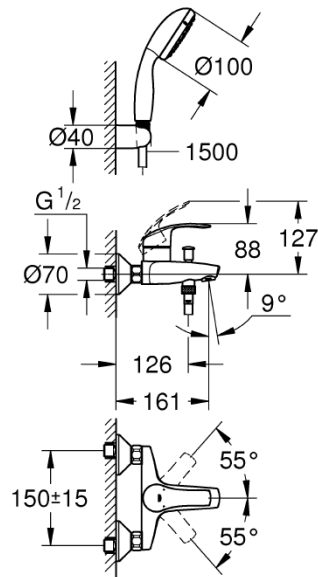

CH

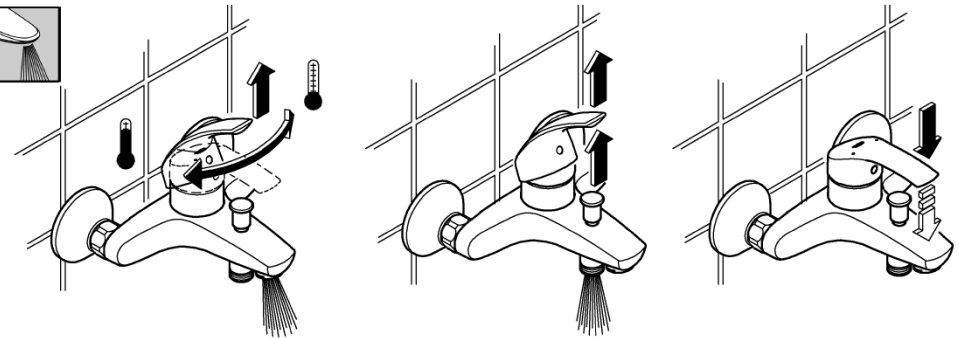
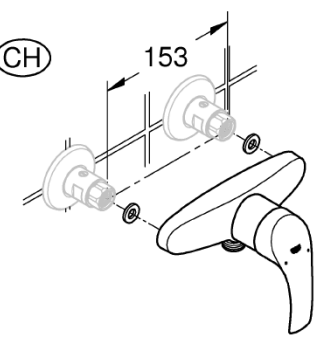

23 460

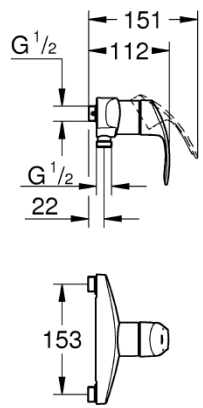

23 461

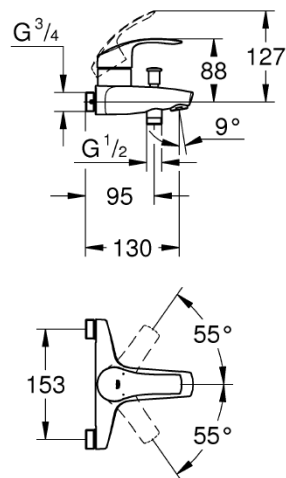

33 300

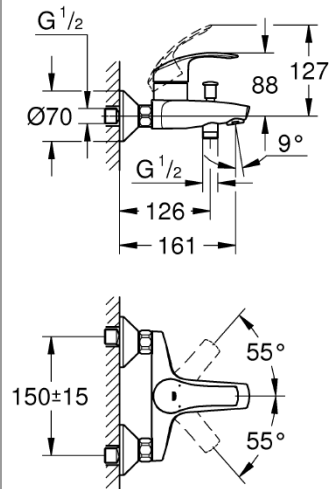

*19 332
32mm

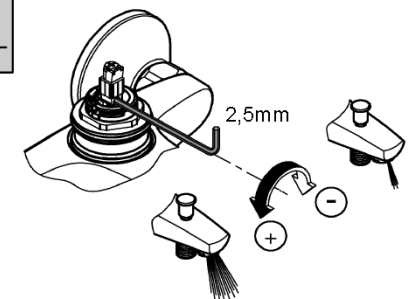
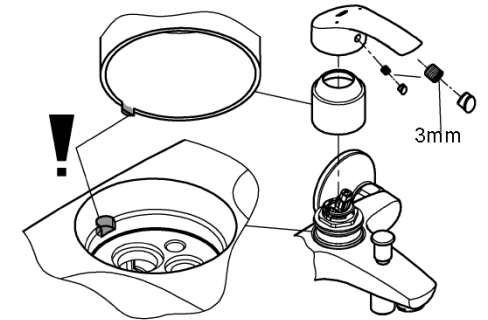
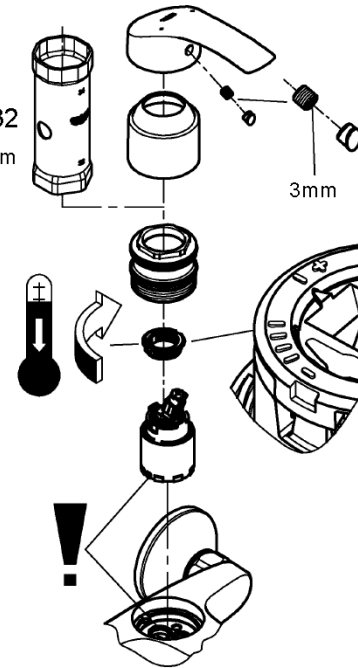



This technical product information is exclusively for the installer or trained specialists.

Please pass these instructions on to the user.

Application:

Operation with unpressurized storage heaters is not possible.

Specifications

Flow pressure:	min. 0.5 bar – recommended 1 – 5 bar
Operating pressure:	max. 10 bar
Test pressure:	16 bar
Flow rate at 3 bar flow pressure	
for bath:	approx. 20 l/min
for shower:	approx. 13 l/min
Hot water inlet temperature:	max. 70 °C
Recommended (energy saving):	60 °C
Thermal disinfection possible:	max. 90 °C

If static pressure exceeds 5 bar, a pressure-reducing valve must be fitted.

Avoid major pressure differences between hot and cold water supply.

GROHE fittings with showers or with pull-out bath spouts/showers are equipped with non-return valves.



Installation:

Flush piping system prior and after installation of fitting thoroughly (Consider EN 806)!

The projection can be increased by 20mm, extension Prod. no: 07 130 (see Replacement parts).

The preassembled temperature limiter is not active in delivery condition.



Function:

Check connections for leaks and check function of fitting.

Flow is diverted automatically from shower outlet to bath inlet when the fitting is closed.



Flow rate limitation:

The use of flow rate limiters in combination with hydraulic instantaneous heaters is not recommended.



Maintenance:

Inspect and clean all components and replace if necessary.

Shut off water supply for maintenance work.



When installing the cartridge, ensure that the seals are correctly seated.

Screw in and tighten screwing.



Replacement parts: see exploded drawing (* = special accessories)

Care: see Care Instructions



Aceste informații tehnice despre produs sunt destinate exclusiv pentru instalator sau personalul de specialitate instruit!

Vă rugăm să le transmiteți utilizatorului!

Domeniu de utilizare

Utilizarea în rețea cu cazane nepresurizate (cazane deschise) nu este posibilă.

Specificații tehnice

Presiune de curgere:	min. 0,5 bar – recomandat 1 – 5 bar
Presiune de lucru:	max. 10 bar
Presiunea de încercare:	16 bar
Debitul la presiunea de curgere de 3 bar	
în vană:	cca. 20 l/min
la duș:	cca. 13 l/min
Temperatură la intrare apă caldă:	max. 70 °C
Recomandat (pentru economisire de energie):	60 °C
Dezinfectarea termică este posibilă:	max. 90 °C

La presiuni de repaus de peste 5 bar se va monta un reductor de presiune.

Se vor evita diferențe de presiune mari între racordurile de apă caldă și rece!

Bateriile GROHE cu duș sau cu pipă și duș mobil sunt echipate cu supape de retur verificate ca tip constructiv.



Instalare:

Spălați temeinic sistemul de conducte înainte și după instalare (Se va respecta norma EN 806)!

Partea de ieșire poate fi prelungită cu 20mm. Număr de catalog pentru prelungitor: 07 130 (a se vedea piese de schimb).

Limitatorul de temperatură montat pe produs nu este activ în starea de livrare a produsului.



Funcționare:

Se verifică etanșeitatea racordurilor și funcționarea bateriei.

La închiderea bateriei, se face trecerea automată de la ieșire duș la ieșire în vană.



Limitatorul de debit:

Nu se recomandă utilizarea limitatorului de debit la încălzitoarele hidraulice instantanee.



Întreținere:

Toate piesele se verifică, se curăță, eventual se înlocuiesc.

În timpul lucrărilor de întreținere se va închide alimentarea cu apă!



La montarea cartușului, se va verifica poziția corectă a garniturilor.

Se înșurubează șuruburile și se strâng bine.



Piese de schimb: a se vedea reprezentarea desfășurată (* = accesorii speciale).

Îngrijire: a se vedea instrucțiunile de îngrijire