

630 EUROSIT GAS CONTROL VALVE

MAIN FEATURES

- Control knob with positions for off, pilot and temperature selection
- Thermoelectric flame failure device with interlock (optional)
- Pressure regulator or alternatively flow adjuster
- Modulating and on-off thermostat
- Pilot outlet with pre-setting device of the gas flow
- Inlet and pilot filter
- Inlet and outlet pressure test point
- Side or bottom main gas inlet and outlet
- Main gas connections with threaded pipe or suitable for compression nut

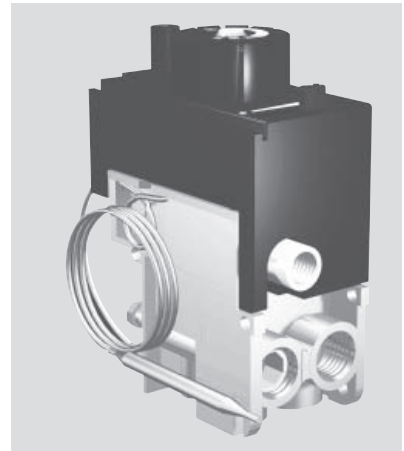

DESCRIPTION

1. Temperature sensor
2. Flow Adjustment
- 2'. Pressure regulator adjustment
3. Minimum Rate Screw
4. Control knob
5. Pilot flow adjustment
6. Inlet pressure test point
7. Outlet pressure test point
8. Pilot outlet
9. Thermocouple connection
10. Side outlet
11. Side inlet
12. Bottom outlet
13. Bottom inlet
14. Valve mounting holes
15. Auxiliary outlet
16. Auxiliary outlet flow adjustment
17. Auxiliary outlet minimum flow adjustment
18. Thermostat flange
19. Safety thermostat (ECO)

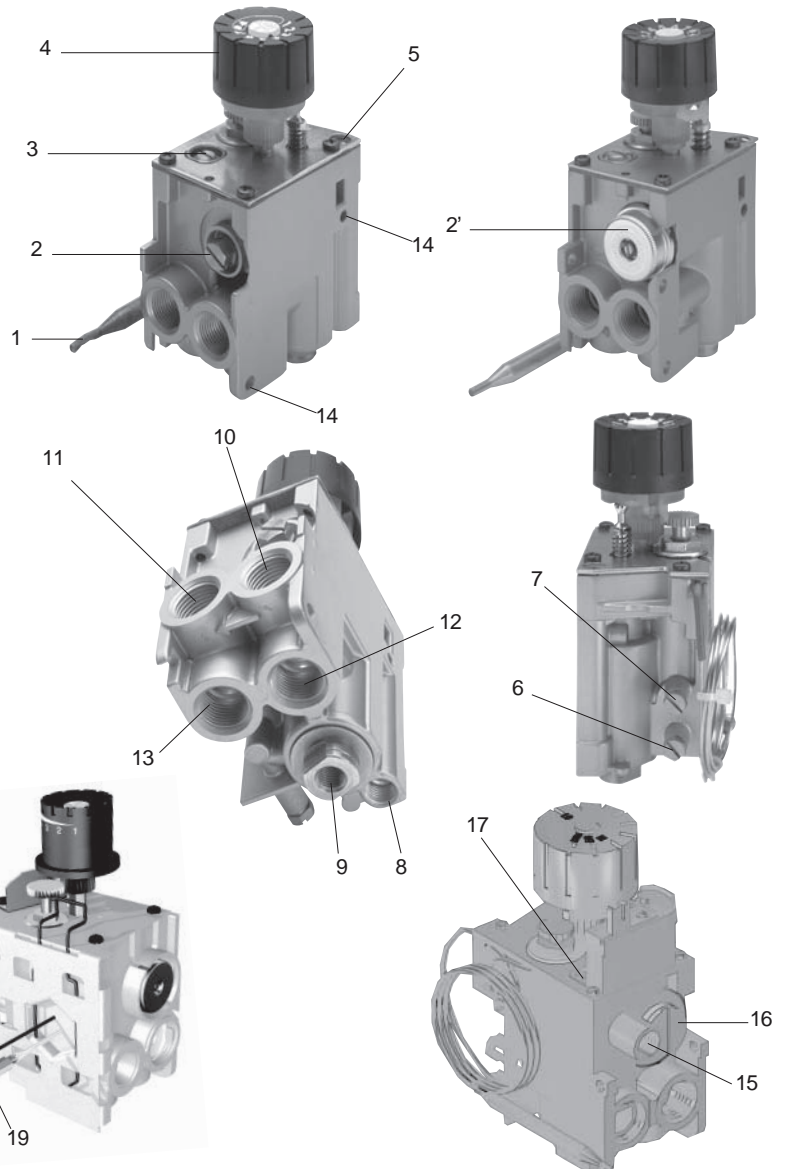

SERVICE NOTE:

Your new Eurosit 630 Series Control Valve can be used with either Natural gas or Liquid Propane Gas and for this reason does not come with a Minimum Rate Screw pre-installed in your new replacement gas valve. You must install the Minimum Rate Screw from your old gas control valve into the new Eurosit 630 Series Gas Control Valve. Remove screw by turning counter clockwise until loose and then remove plug by grabbing firmly and lifting the plug directly up. Lube the O-ring on your previous Minimum Rate Screw with a light layer of silicone or assembly grease and install the Minimum Rate Screw into your new gas control valve. Reassemble and install gas control valve and test all connections and Minimum Rate Screw for leaks before starting your appliance.

Note: This repair should be conducted by a certified and licensed contractor and tested for leaks before use.

INSTALLATION

The 630 EUROSIT complies with current safety standards. Nevertheless, its installation on appliances must be verified in accordance with the specific standards for each installation. In particular, it is necessary to ensure that the requirements relating to the class of flame failure device are met. All the installation, setting and adjustment operations must be carried out exclusively by qualified personnel on the basis of the specific characteristics of the appliance. This valve is not for outdoor use.

MECHANICAL CONNECTIONS

General recommendations

Do not tamper with sealed parts. Do not slacken assembly screws. Do not remove labels. Avoid blows (knocks, falls etc.). Only remove dust caps when installing. Do not exceed recommended torques. Ensure that the gas flows in the direction shown by the arrow on the valve body. Prevent foreign matter from getting into the valve during installation. In particular, check the cleanliness of the inlet and outlet pipes. Do not subject the valve to bending in excess of 25 lb-ft and to torque in excess of 18 lb-ft. Use only the specified wrenches when making the connections. The valve has 3 pairs of retaining holes.

Main gas connection

The connection must be made using gas pipes with Rp 3/8 ISO 7 thread.

Torque: 18 lb-ft. Alternatively, it is possible to use a compression fitting connection for Ø 12 mm pipe (codes 0.958.025 and 0.957.007) (torque 11 lb-ft). The valve has two main gas inlets (10 and 12) and two main gas outlets (11 and 13). The outlets which are not used must be sealed by fully screwing in the specified plug torque 5 lb-ft. (code 0.972.058)

Connection to the pilot burner outlet (8) Ø 4 mm, 6 mm or Ø 1/4" pipes can be used. Use appropriately sized compression nut and ferrule. Tighten to 5 lb-ft torque.

After making the gas connections, check seals and ensure appliance works properly.

