

APPLICATIONS



Boiler



Dehumidifier

PUMPING DISTANCE

4.5 m



50 m

WARRANTY (page 8)



Product Code:
SK6N
Barcode:
EAN 3308815081410



APPLICATIONS



Boiler

WARRANTY (page 8)



SANINEUTRAL® Mini
Product Code:
1082/7
Barcode:
EAN 3308815075778

SANINEUTRAL®
Product Code:
1082/4
Barcode:
EAN 3308815060927



SANICONDENS® Best Flat



Low entry for floor standing boilers
Easy installation:
Complete installation kit supplied with non-return valve, integrated neutralisation system and alarm pre-connection.



Integrated neutralisation system to protect pipes from acid attacks. Complete and compact system.
Quiet unit.

SEMI-TRANSPARENT VIEW



TECHNICAL FEATURES

Ø inlet	28 mm
Number of possible inlets	3
Ø discharge pipework	32 mm
Tank volume	3.5 l
Maximum flow	380 l/h
Maximum incoming water temperature	80°C
Max power of gas boiler	80 kW
Max power of oil boiler	50 kW
Voltage	220-240 V
Supply frequency	50 Hz
Max power	60 W
Electrical class	Single phase
IP rating	IP20
Weight	2 kg
Low noise level	< 45 dB(A)

PUMP CURVE

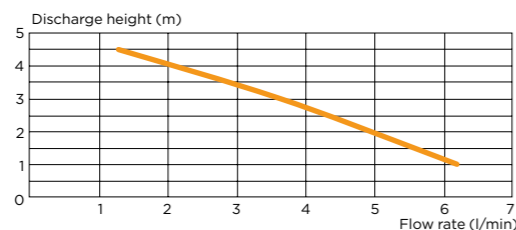

PACKAGING

SANICONDENS® Best Flat

Wall mounting and non-return valve supplied

Delivered with: fixing screw, 1 inlet adapter, 1 outlet adapter (50mm), 1 drain hose (5m) internal diameter 10mm, and 1 power cable of 1.5m, 1 alarm cable 2 strands 1.5m.

SANINEUTRAL® Mini

SANINEUTRAL®



Easy installation: Supplied with granules included. Fits wall and floor boilers. Wall or floor mounting possible.

Simplified maintenance: Cover can be removed without disconnecting the pipes.



Transparency: allows visibility of the condition of the granules.

Preserve the pipes from acid attacks.

Small unit (mini).

INSTALLATION DRAWING

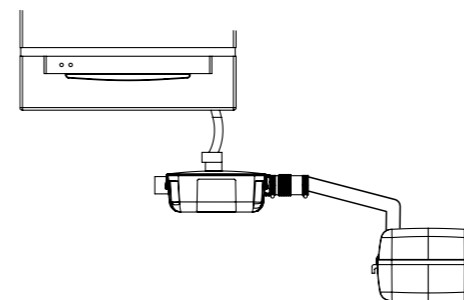

TECHNICAL FEATURES

Number of possible inlets	2
Diameter of the inlet on the top (fitting supplied)	40/32/28 mm (Mini: 32/40 mm)
Inlet diameter on the side (fitting supplied)	40 mm (Mini: 32 mm)
Minimum Ph	2.5
Max power of gas boiler	50 kW (Mini: 25 kW)
Max power of oil boiler	35 kW (SANINEUTRAL only)

NEUTRALISATION GRANULES



Transparent sachet to control the level of granules

Neutralisation granules
Ref: SACHGRANULE

The granules neutralise the acidity of the condensates of the boiler. Replace approximately once a year.

Barcode : EAN 3308815011134

PACKAGING

SANINEUTRAL® with inlet and outlet fittings

SANINEUTRAL® Mini with integrated siphon

Supplied with wall mounting brackets

Ground fixing system (SANINEUTRAL)