

### Destinatar

Firma  
Referinta  
Adresa  
Phone  
Fax  
E-mail

### Expeditor

#### Cod articol :

60191240

#### Articol:

GRINDER FX 15.11 M-NA

#### Tip de instalatie:

Wet - Pump only

#### Date pompa

Free passage : --  
Max. immersion depth : 20 m  
Temperatura min. fluid : 0 °C  
Temperatura max. fluid : 50 °C

#### Date de functionare cerute

Debit :  
Înaltime de pompare :  
Fluid pompat : Apă  
Temperatura fluid: 20 °C  
Densitate : 998.3 kg/m³  
Vascozitate cinematica: 1.005 mm²/s  
Presiune de vapori: 2.34 kPa

#### Date disponibile:

Debit :  
Înaltime de pompare :

#### Materiale

Maner : Fonta EN GJL 200  
Pump body / motor : Fonta EN GJL 200  
Rotor : Cast iron (EN GJL 250)  
Etansare mec. completa pe partea pozitiva : Sic/SIC-C  
Etansare mec. completa pe partea negativa : Carbon  
Garnitura OR : NBR  
Cutter / Cutter Base : Steel EN1.4542 / AISI 630

#### Date motor

Marca : DAB  
Putere nominala P2: 1.1 kW  
Viteza nominala: 2870 1/min  
Tensiune nominala : 1~ 230 V 50 Hz  
Curent nominal : 6.8 A  
Grad de protectie: IP 68

#### Curve tolerance according to ISO 9906

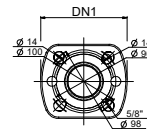
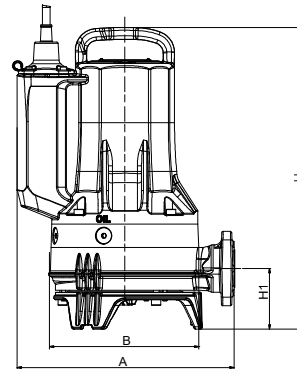
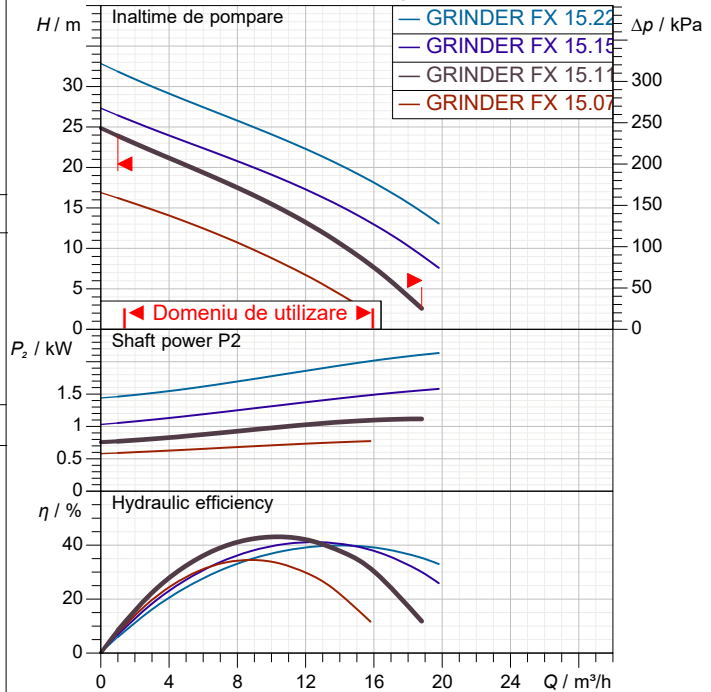

Masa 35 kg Accessory weight :

#### Dimensiuni de gabarit mm

A	306				
B	215				
DN1	32, 40				
GAS	Rp 1"1/2				
H	404				
H1	87				

#### Racorduri pompa:

Partea cu aspiratia: --  
Partea cu refularea: Rp 1"1/2 - DN 32 PN10/6, DN 40 PN6



# CURBELOR CARACTERISTICE

07/30/2021

Pagina 2 / 3

DAB PUMPS S.p.A.  
Via Marco Polo, 14 - 35035 Mestrino (PD), Italy  
Tel. +39 049 5125000 - Fax +39 049 5125950  
www.dabpumps.com

Destinatar

Expeditor

Firma  
Referinta  
Adresa  
Phone  
Fax  
E-mail

## GRINDER FX 15.11 M-NA

Curve tolerance according to ISO 9906

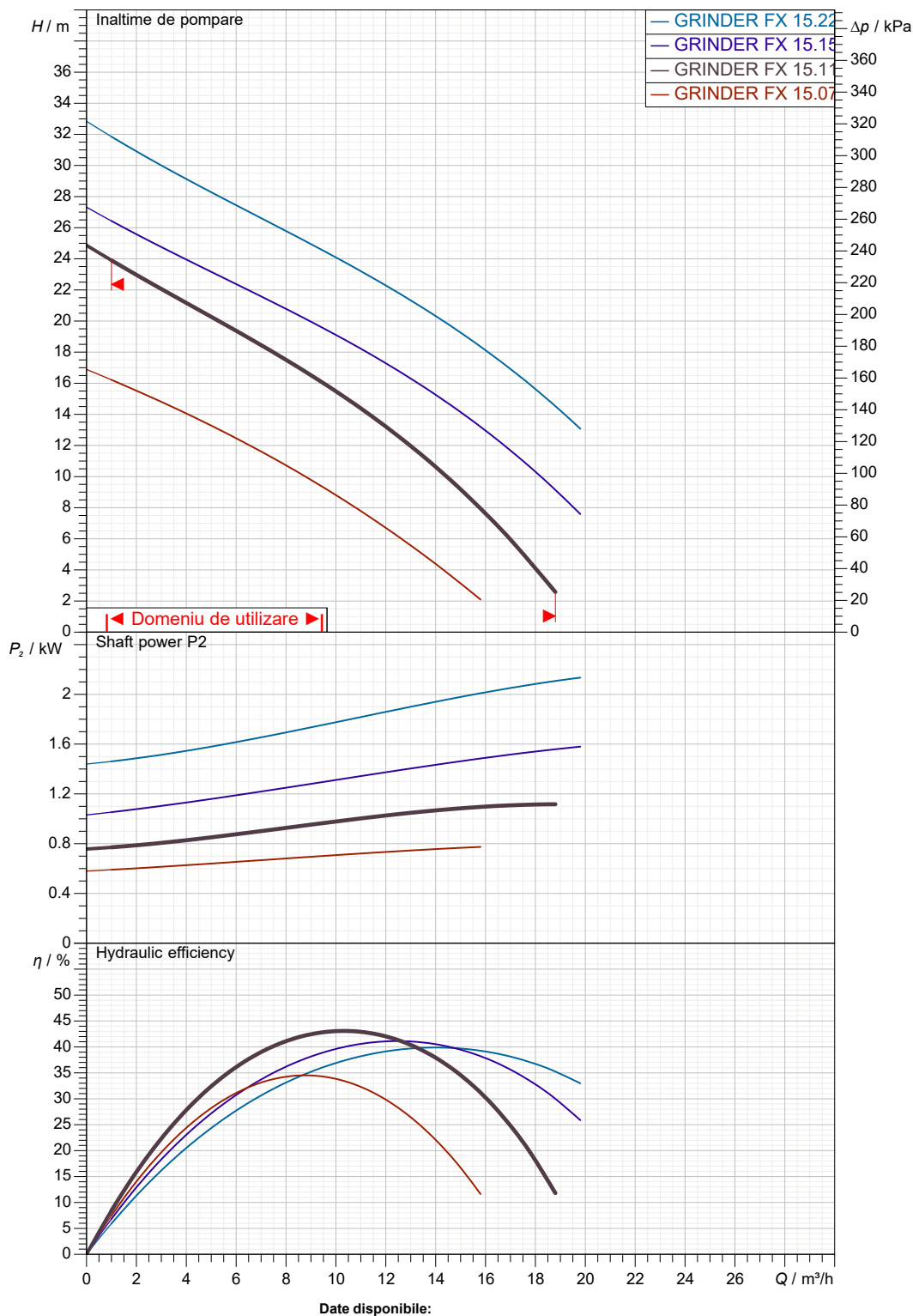

Date disponibile:

Partea cu aspiratia:

Partea cu refularea:  
Rp 1"1/2 - DN 32 PN10/6, DN 40 PN6  
--

Debit :

Înaltime de pompare :

Viteza nominala:  
2870 1/min

MAIN\_PROJECT\_TITLE

BUSINESS\_PROCESS\_IC

OWNER\_

ISSUE\_DATE



# DESEN DIMENSIONAL

07/30/2021

Pagina 3 / 3

DAB PUMPS S.p.A.  
Via Marco Polo, 14 - 35035 Mestrino (PD), Italy  
Tel. +39 049 5125000 - Fax +39 049 5125950  
www.dabpumps.com

Destinatar

Expeditor

Firma  
Referinta  
Adresa  
Phone  
Fax  
E-mail

## GRINDER FX 15.11 M-NA

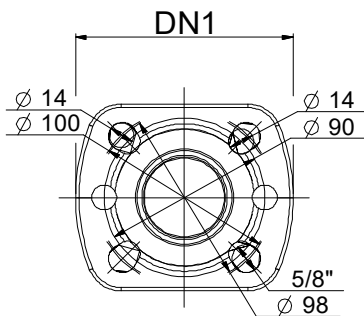
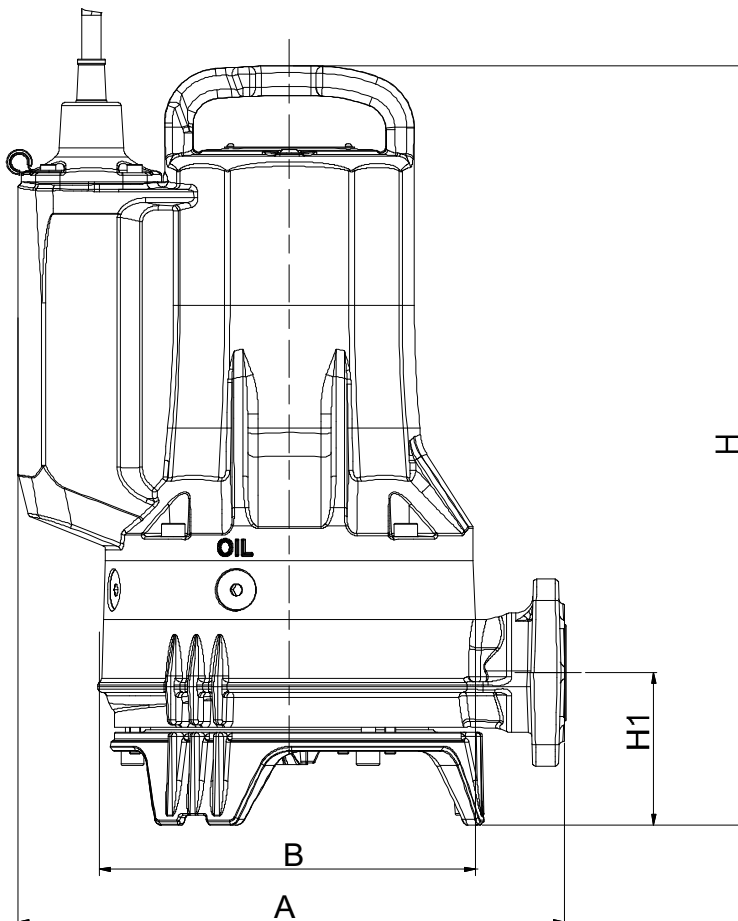

**Dimensiuni in mm**

1	A	306
2	B	215
3	DN1	32, 40
4	GAS	Rp 1"1/12
5	H	404
6	H1	87
7		
8		
9		
10		
11		
12		

**Racorduri pompa:**

Aspiratie  
  
Refulare  
Rp 1"1/2 - DN 32 PN10/6, DN 40 PN6  
--

MAIN\_PROJECT\_TITLE

BUSINESS\_PROCESS\_ID

OWNER

ISSUE\_DATE