

**Destinatar**

**Expeditor**

Firma  
Referinta  
Adresa  
Phone  
Fax  
E-mail

**Drainage station**

FEKAFOS 550 DOUBLE

Cod articol :

60166306

**Pompa tip**

DRENAG FX 15.22 T-NA 400 50 Hz

Cod articol :

60191277

**Date pompa**

Presiune nominala: --  
Temperatura min. fluid 0 °C  
Temperatura max. fluid 45 °C  
Temperatura max. ambianta

**Date de functionare cerute**

Debit :  
Înălțime de pompare :  
Fluid pompat : Apă  
Temperatura fluid: 20 °C  
Densitate 998 kg/m<sup>3</sup>  
Vascozitate cinematica: 1 mm<sup>2</sup>/s  
Presiune de vapori: 2.34 kPa

**Date disponibile:**

Debit :  
Înălțime de pompare :

**Materiale**

Cisterna High density polyethylene

**Curve tolerance according to ISO 9906**

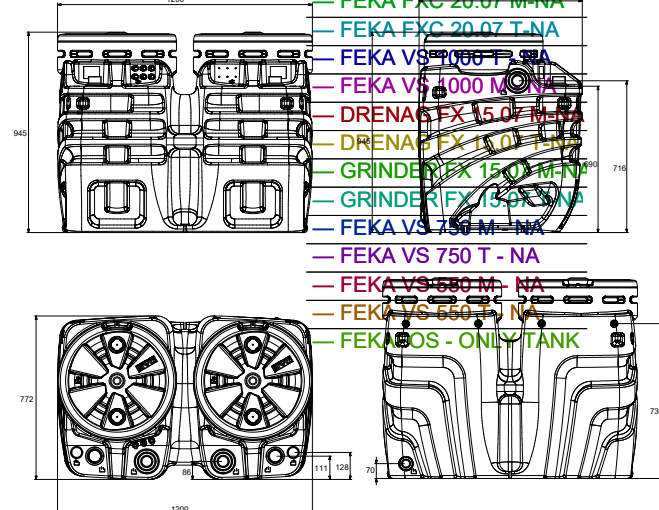
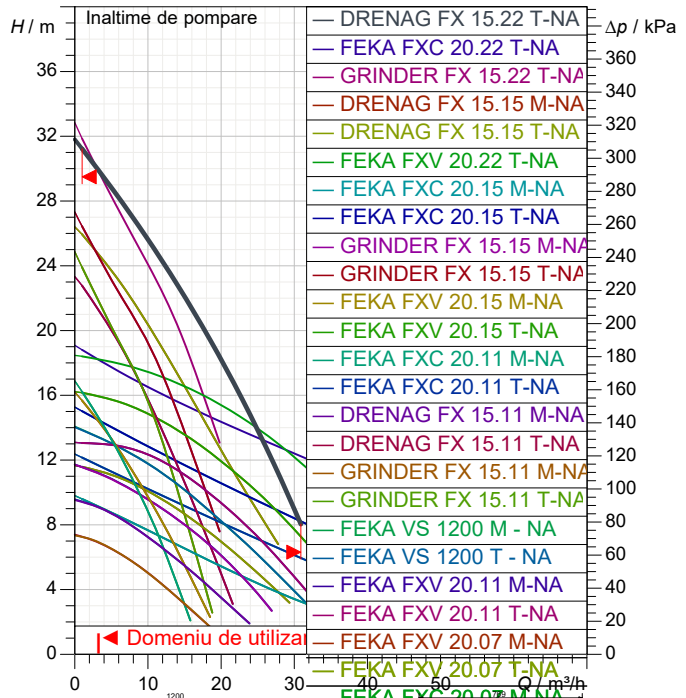

Tank weight : 74 kg

**Dimensiuni de gabarit mm**

--	--	--	--	--

**Racorduri pompa:**

Partea cu aspiratia: DN 50/110  
Ventilation : DN 50  
Partea cu refularea: 2" G



# CURBELOR CARACTERISTICE

12/03/2021

Pagina 2 / 3

DAB PUMPS S.p.A.  
Via Marco Polo, 14 - 35035 Mestrino (PD), Italy  
Tel. +39 049 5125000 - Fax +39 049 5125950  
www.dabpumps.com

Destinatar

Expedito

Firma  
Referinta  
Adresa  
Phone  
Fax  
E-mail

## FEKAFOS 550 DOUBLE

Curve tolerance according to ISO 9906

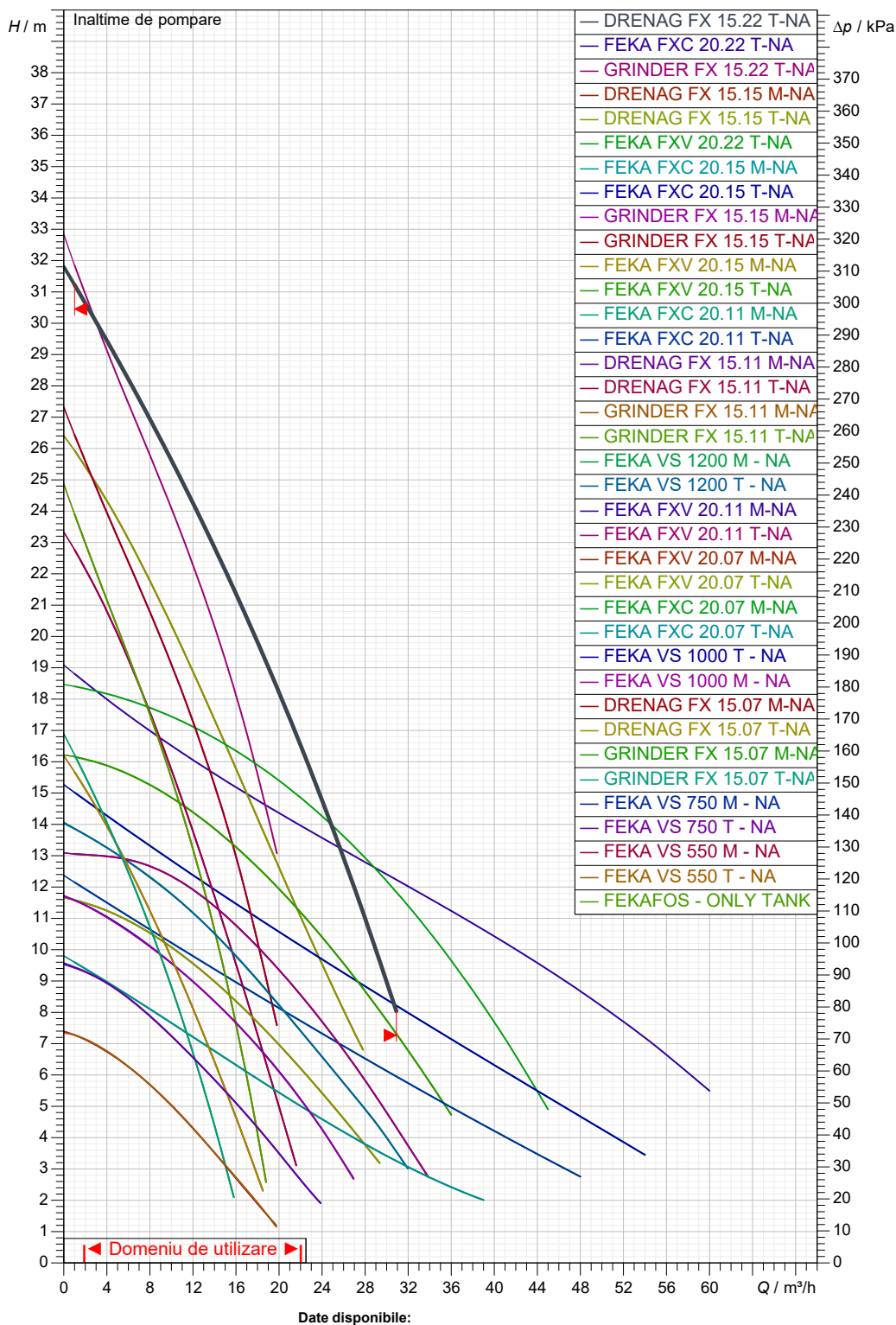

Partea cu aspiratia:  
DN 50/110  
--

Partea cu refularea:  
2" G  
--

Debit :

Inaltime de pompare :

Viteza nominala:  
2870 1/min

MAIN\_PROJECT\_TITLE

BUSINESS\_PROCESS\_ID

OWNER\_

ISSUE\_DATE



# DESEN DIMENSIONAL

12/03/2021

Pagina 3 / 3

DAB PUMPS S.p.A.  
Via Marco Polo, 14 - 35035 Mestrino (PD), Italy  
Tel. +39 049 5125000 - Fax +39 049 5125950  
www.dabpumps.com

Destinatar

Expeditor

Firma  
Referinta  
Adresa  
Phone  
Fax  
E-mail

## FEKAFOS 550 DOUBLE

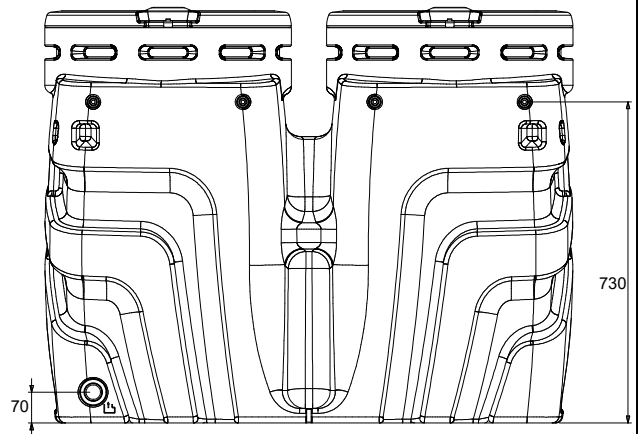
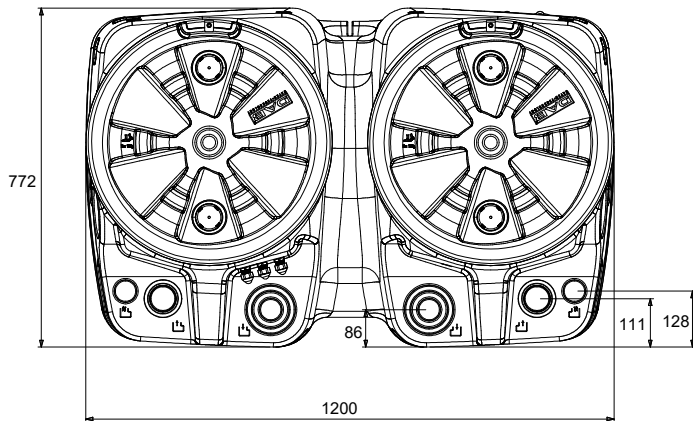
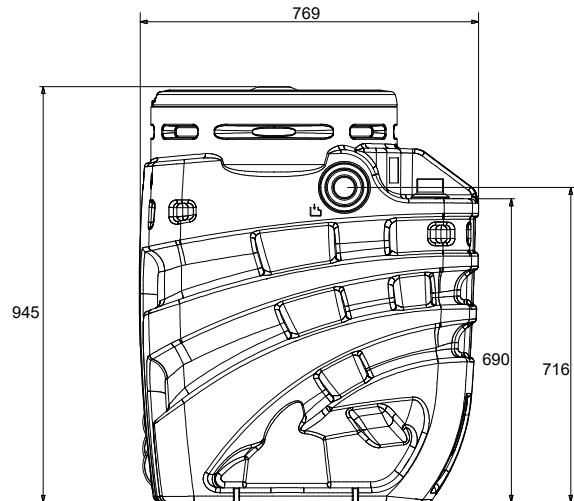
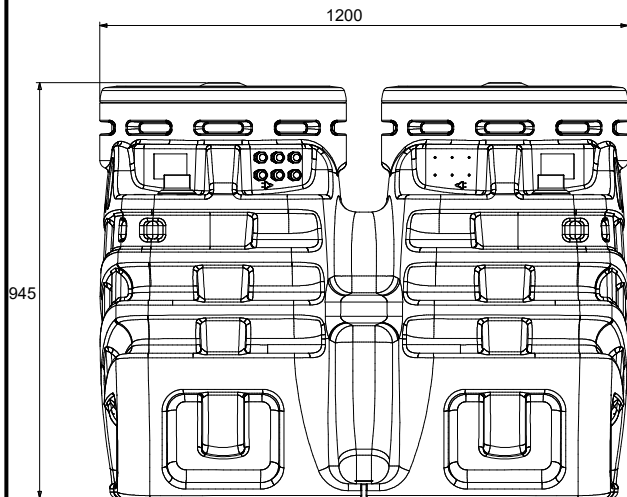

Dimensiuni in mm

Racorduri pompa:

- 1
- 2
- 3
- 4
- 5
- 6
- 7
- 8
- 9
- 10
- 11
- 12

Aspiratie  
DN 50/110  
--  
  
Refulare  
2" G  
--

MAIN\_PROJECT\_TITLE

BUSINESS\_PROCESS\_ID

OWNER

ISSUE\_DATE