

Destinatar

 Firma
 Referinta
 Adresa
 Phone
 Fax
 E-mail

Expeditor
Cod articol :

102662000

Articol:

JET 62 M-P

Date pompa

 Presiune nominala: 6 bar (600 kPa)
 Temperatura min. fluid 0 °C
 Temperatura max. fluid 35 °C
 Temperatura max. ambienta 40 °C

Capacitate de amorsare:

H	m	2	3	4	5	6	7	8	9
Q	m ³ /h	2.46	2.28	2.04	1.86	1.62	1.32	1.14	0.78

Date de functionare cerute

 Debit :
 Inaltime de pompa :
 Fluid pompat : Apă
 Temperatura fluid: 20 °C
 Densitate 998.3 kg/m³
 Viscositate cinematica: 1.005 mm²/s
 Presiune de vapori: 2.34 kPa

Date disponibile:

 Debit :
 Inaltime de pompa :

Materiale

 Corp pompa Fonta 200 UNI ISO 185
 Suport Aluminiu turnat la cald
 Rotor Tecnopolimer A
 Etansare mecanica Carbon/Ceramica
 Garnitura OR Cauciuc NBR
 Arbore cu rotor AISI 416 X12 CrS 13 UNI 6900/71
 Grup duza difuzor venturi Tecnopolimer A

Date motor

 Marca : DAB
 Putere nominala P2: 0.44 kW
 Viteza nominala: 2850 1/min
 Tensiune nominala : 1~ 220-240 V 50 Hz
 Curent nominal : 3.12 A
 Grad de protectie: IP 44

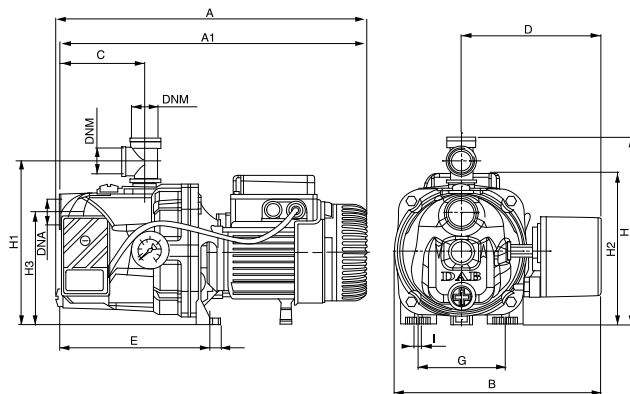
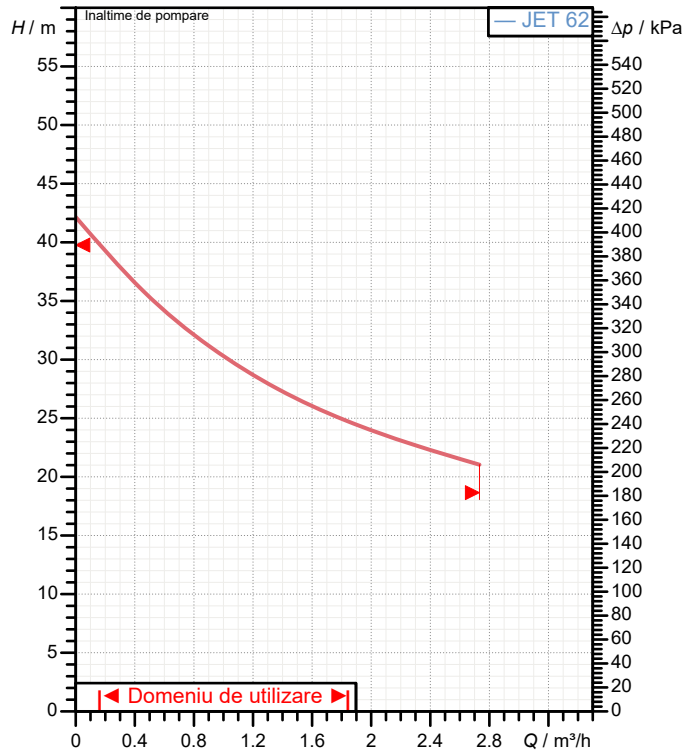
Curve tolerance according to ISO 9906

Dimensiuni de gabarit mm

A	395	D	177	F	14	H2	193
A1	390	DNA	1" G	G	111	H3	144
B	263	DNM	1" G	H	239	I	9
C	108	E	192	H1	209	I Ø	-

Masa 11.9 kg

Racorduri pompa:

 Partea cu aspiratia: 1" G / 6 bar (600 kPa)
 Partea cu refularea: 1" G / 6 bar (600 kPa)



CURBELOR CARACTERISTICE

11/20/2020

Pagina 2 / 3

DAB PUMPS S.p.A.
Via Marco Polo, 14 - 35035 Mestrino (PD), Italy
Tel. +39 049 5125000 - Fax +39 049 5125950
www.dabpumps.com

Destinatar

Expeditor

Firma
Referinta
Adresa
Phone
Fax
E-mail

JET 62 M-P

Curve tolerance according to ISO 9906

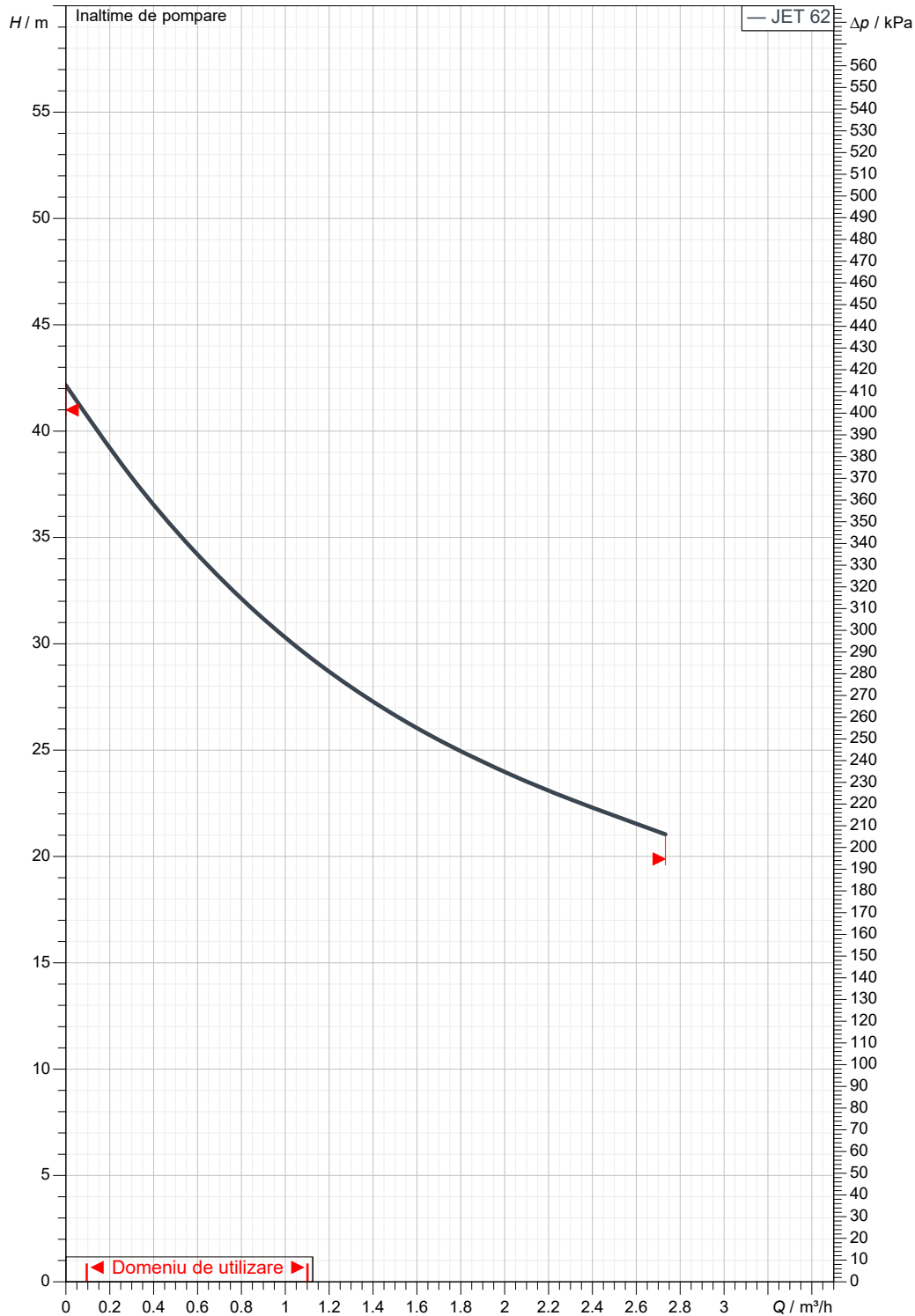

Date disponibile:

Partea cu aspiratia:
1" G
6 bar (600 kPa)

Partea cu refularea:
1" G
6 bar (600 kPa)

Debit :

Înaltime de pompare :

Viteza nominala:
2850 1/min

MAIN_PROJECT_TITLE

BUSINESS_PROCESS_IC

OWNER_

ISSUE_DATE

11/20/2020



DESEN DIMENSIONAL

11/20/2020

Pagina 3 / 3

DAB PUMPS S.p.A.
Via Marco Polo, 14 - 35035 Mestrino (PD), Italy
Tel. +39 049 5125000 - Fax +39 049 5125950
www.dabpumps.com

Destinatar

Expeditor

Firma
Referinta
Adresa
Phone
Fax
E-mail

JET 62 M-P

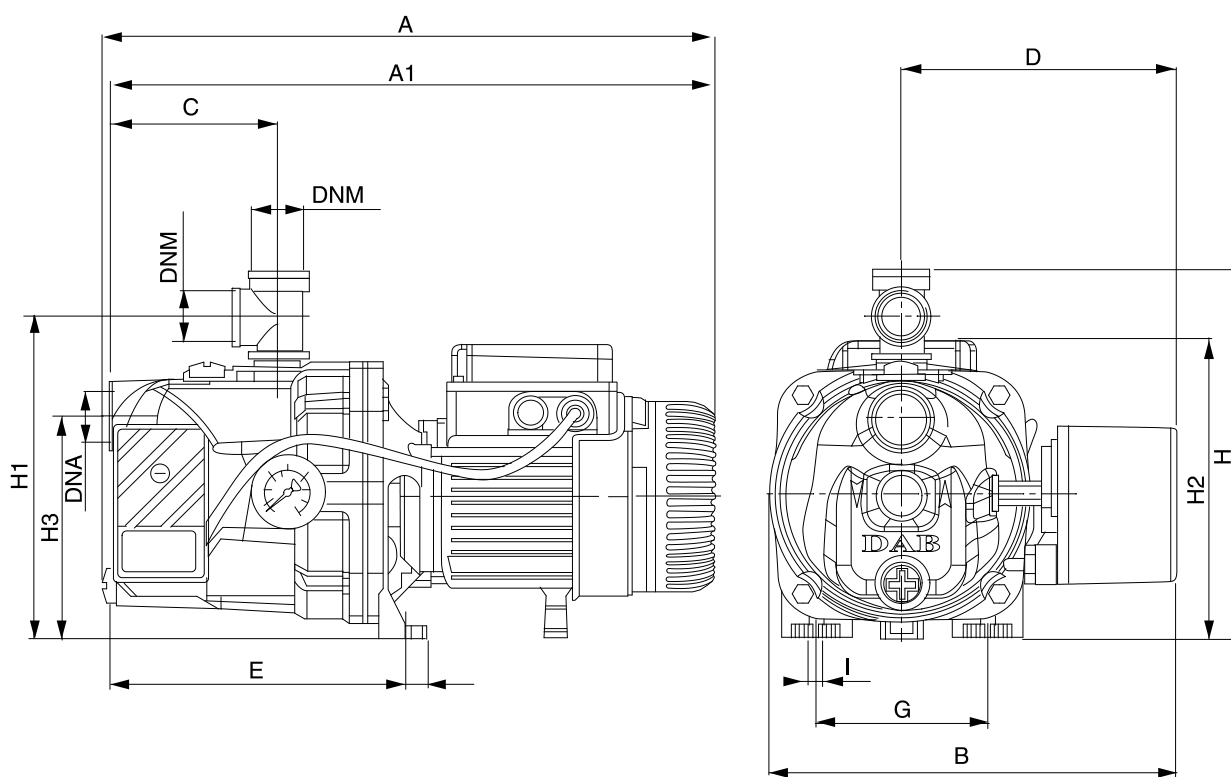

Dimensiuni in mm

Racorduri pompa:

1	A	395	H2	193		
2	A1	390	H3	144		Aspiratie
3	B	263	I	9		1" G
4	C	108	I Ø	-		6 bar (600 kPa)
5	D	177				
6	DNA	1" G				
7	DNM	1" G				
8	E	192				Refulare
9	F	14				1" G
10	G	111				6 bar (600 kPa)
11	H	239				
12	H1	209				

MAIN_PROJECT_TITLE

BUSINESS_PROCESS_ID

OWNER

ISSUE_DATE

11/20/2020

ACTIVE DRIVER PLUS

INVERTER FOR ELECTRIC PUMPS



TECHNICAL DATA

Line voltage: 115V e 230V single phase. 400V three-phase.
Electric pump voltage: 115V e 230V single phase, 230V e 400V three-phase.
Frequency: 50 Hz - 60 Hz.
Installation: vertical or horizontal (for M/M e M/T).
Max. liquid temperature: 50°C.
Max. operational temperature: 50°C.
Portata max: 18m³/h.
Max. pressure: 13 bar.
Pressure regulation range: from 1 to 13 bar.
Aspiration diameter (DNA): 1 1/4" male.
Discharge diameter (DNM): 1 1/2" female.
Protection rating: IP55.
Check valve: integrated.
Communication interface for sets: Yes, an Active Driver per pump.

APPLICATIONS

The units with Active Driver were designed and manufactured to meet the needs for constant **pressure required** by modern plumbing systems. Constant pressure regulation is applicable to many sectors: Water supply for irrigation, industry, hotels, housing construction, thermal baths. The basic concept that guided our Engineers in the development of these units was to manufacture a system that is **simple, flexible and reliable**.

ADVANTAGES

Constant pressure - Quiet operation - Economical - Reduced water consumption - Smaller footprint (Expansion tanks not required) Less maintenance - Dry-running protection - Complete protection of the pump from faults.

ACTIVE DRIVER NOTES

The Active Driver inverter is a pump control device that includes the connections to the hydraulic system, a pressure sensor, a flow sensor, and an electronic frequency inverter. Active Driver is applied on the delivery of **each electric pump**, and regulates the rotation speed of the pump it is connected to, so that the **pressure is kept constant** in spite of variations in the required flow rate. The water flowing through the Active Driver Plus connections also contributes to **eliminating the heat** produced by the internal electric components.

OPERATION

Active Driver orders the pump to start as soon as it detects a request of water. The speed of the pump is (consistently) regulated at the minimum value that meets the request of the user. This ensures important energy savings. In this set, the second and third pump are activated in cascade when the first pump reaches the maximum rotation speed. The pump pressure may be adjusted by the user using the + and - buttons on Active Driver (usually all of the pumps are set at the same pressure level).

The pumps stop automatically when there is:

Pump overload - dry-running - low voltage - Maximum pressure exceeded (adjustable) - Active Driver electronics overheating.

ACTIVE DRIVER FUNCTIONS DISPLAYED

Pump operational frequency (Hz) - Real-time pressure (bar) - Amperes absorbed by the pump - Alarms.

ACTIVE DRIVER EXTERNAL CONNECTIONS (models M/T 2.2 - T/T 3.0 - T/T 5.5 only)

Inputs: pump disabling, pressure switch, float against dry operation, second pressure setpoint.

Outputs: two terminals with no potential for signaling alarms, pump stop, pump running.

MATERIALS

N°	PARTS*	MATERIALS
1	ACTIVE DRIVER PLUS BODY	VERPLEN
2	THREADED BRASS INSERT - 1-1/2 GAS	BRASS
3	VNR HOUSING	NORYL
4 - 10 - 12 - 15 - 16 - 19	O-RING	NBR
5 - 20	O-RING	EPDM 70 WRAS
6	VNR GUIDE	NORYL
7	VNR BODY	NORYL
8	MAGNET	FERRITE + PARYLENE
9	VNR COVER	NORYL
11	O-RING	SILORPREN
13	SPRING SP1	STAINLESS STEEL
14	SCREW	STAINLESS STEEL
17	INSERT - 3/8" GAS	PPE 20GF
18	PRESSURE SENSOR	STAINLESS STEEL
21	HEAT DISPERSER	BRASS

* In contact with the liquid.

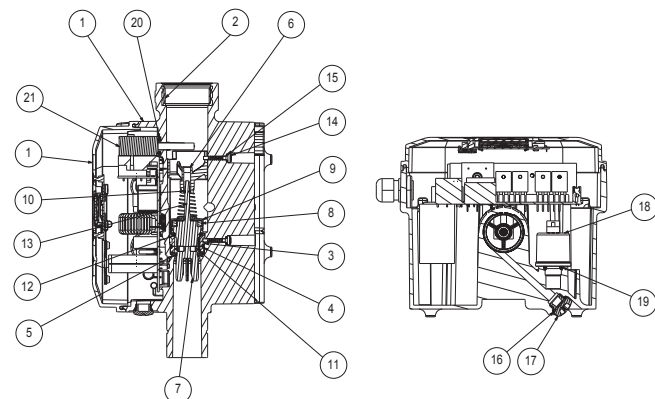

ACTIVE DRIVER PLUS

INVERTER FOR ELECTRIC PUMPS

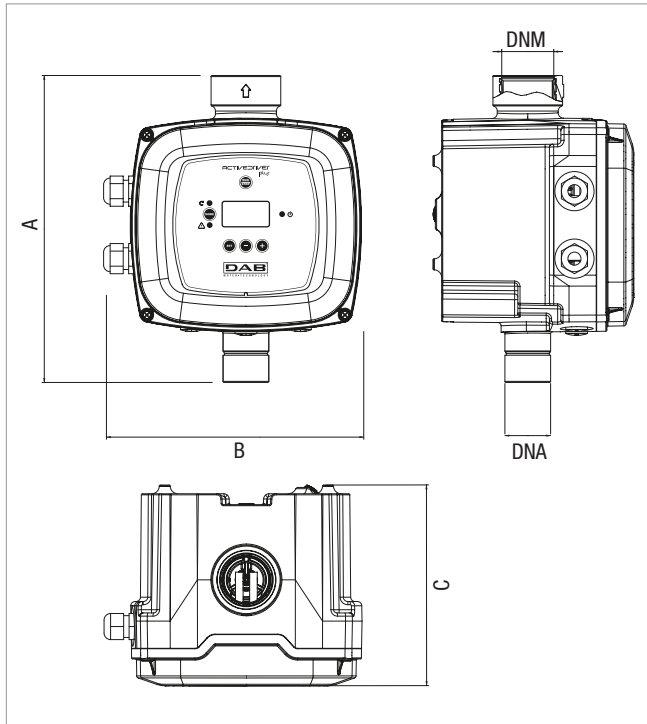

MODEL	A	B	C	DNM	DNA	PACKING DIMENSIONS			WEIGHT Kg
						L/A	L/B	H	
ACTIVE DRIVER PLUS M/M 1.1	237	282	185	1" 1/2F	1" 1/4M	340	270	220	3,5
ACTIVE DRIVER PLUS M/M 1.5	237	282	185	1" 1/2F	1" 1/4M	340	270	220	3,5
ACTIVE DRIVER PLUS M/M 1.8	237	282	185	1" 1/2F	1" 1/4M	340	270	220	3,8
ACTIVE DRIVER PLUS M/T 1.0	237	282	185	1" 1/2F	1" 1/4M	340	270	220	3,5
ACTIVE DRIVER PLUS M/T 2.2	237	282	185	1" 1/2F	1" 1/4M	340	270	220	3,5
ACTIVE DRIVER PLUS T/T 3.0	237	282	185	1" 1/2F	1" 1/4M	340	270	220	4,5
ACTIVE DRIVER PLUS T/T 5.5	237	282	185	1" 1/2F	1" 1/4M	340	270	220	4,6

MODEL	MAX CURRENT MOTOR A	MAX POWER MOTOR KW	POWER SUPPLY 50 Hz	POWER SUPPLY ELECTRIC PUMP	COMMUNICATION INTERFACE FOR SETS	USE WITH PUMP TYPE	ADJUSTMENT PRESSURE BAR
ACTIVE DRIVER PLUS M/M 1.1	8,5	1,1	Single phase 1x230	Single phase 1x230	YES	Surface pumps, submerged 4" and 5" with single phase motor with current draw up to 8.5 A	1-9
ACTIVE DRIVER PLUS M/M 1.5	11	0,55	Single phase 1x115	Single phase 1x115	YES	Surface pumps, submerged 4" and 5" with single phase motor with current draw up to 11 A	1-9
		1,5	1x230	1x230			
ACTIVE DRIVER PLUS M/M 1.8	14	1,0	Single phase 1x115	Single phase 1x115	YES	Surface pumps, submerged 4" and 5" with single phase motor with current draw up to 14 A	1-9
		1,8	1x230	1x230			
ACTIVE DRIVER PLUS M/T 1.0	4,7	1,0	Single phase 1x230	Three-phase 3x230	YES	Surface pumps, submerged 4" and 5" with 230 V three-phase motor with current draw up to 4.7 A	1-9
ACTIVE DRIVER PLUS M/T 2.2	10,5	2,2	Single phase 1x230	Three-phase 3x230	YES	Surface pumps, submerged 4" and 5" with 230 V three-phase motor with current draw up to 10.5 A	1-13
ACTIVE DRIVER PLUS T/T 3.0	7,5	3,0	Three-phase 3x400	Three-phase 3x400	YES	Surface pumps, submerged 4" and 5" with 400 V three-phase motor with current draw up to 7.5 A	1-13
ACTIVE DRIVER PLUS T/T 5.5	13,3	5,5	Three-phase 3x400	Three-phase 3x400	YES	Surface pumps, submerged 4" and 5" with 400 V three-phase motor with current draw up to 13.3 A	1-13