

Rev	Design Change Note	Author	Date
A	Internal validation	ZP	2018-10-05
001	Approved by the client	ZP	2018-12-21
002	base points added	ZP	2019-07-24

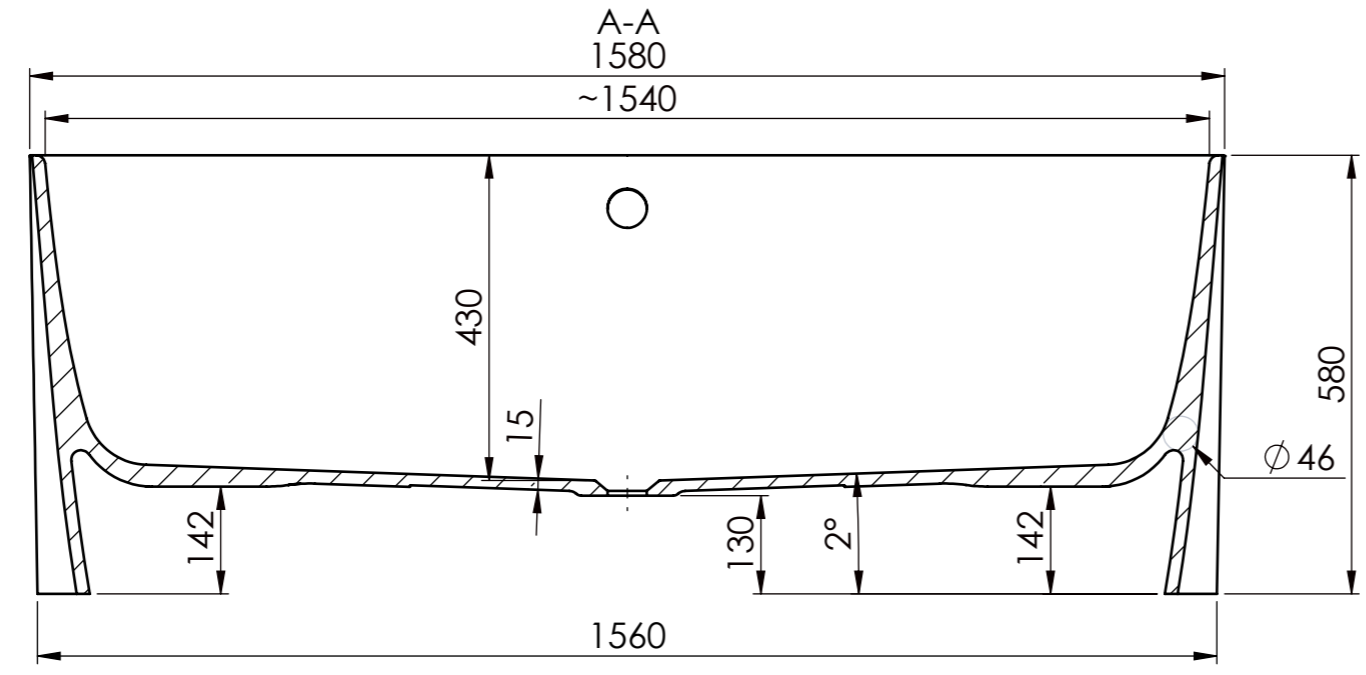

C (1 : 5)
wymiar do ustawienia
maszyny - odległości cięcia.

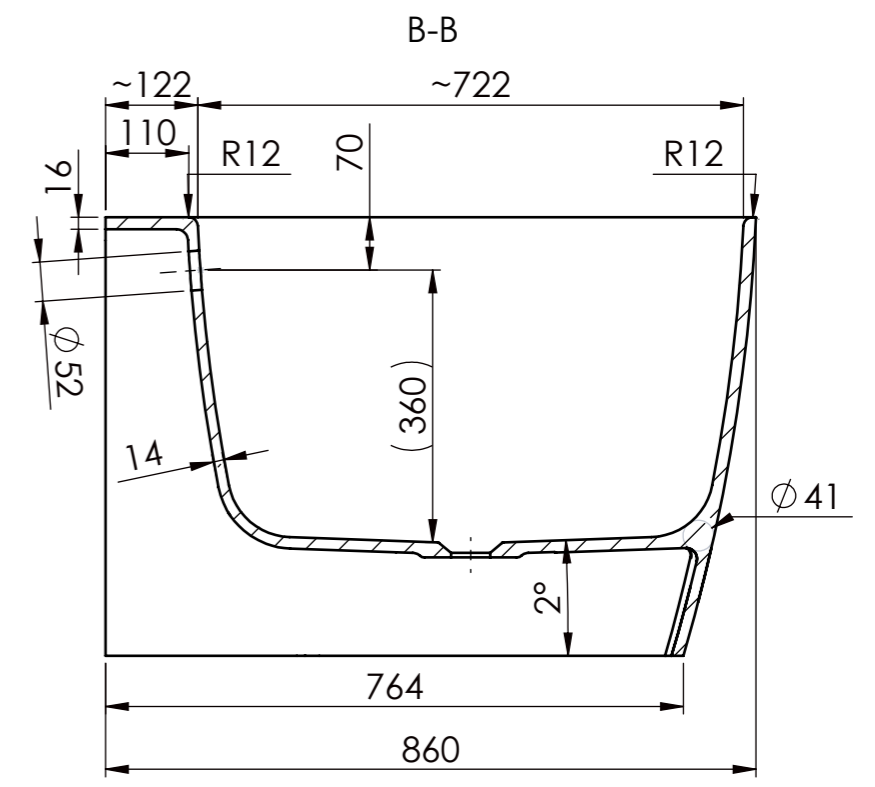
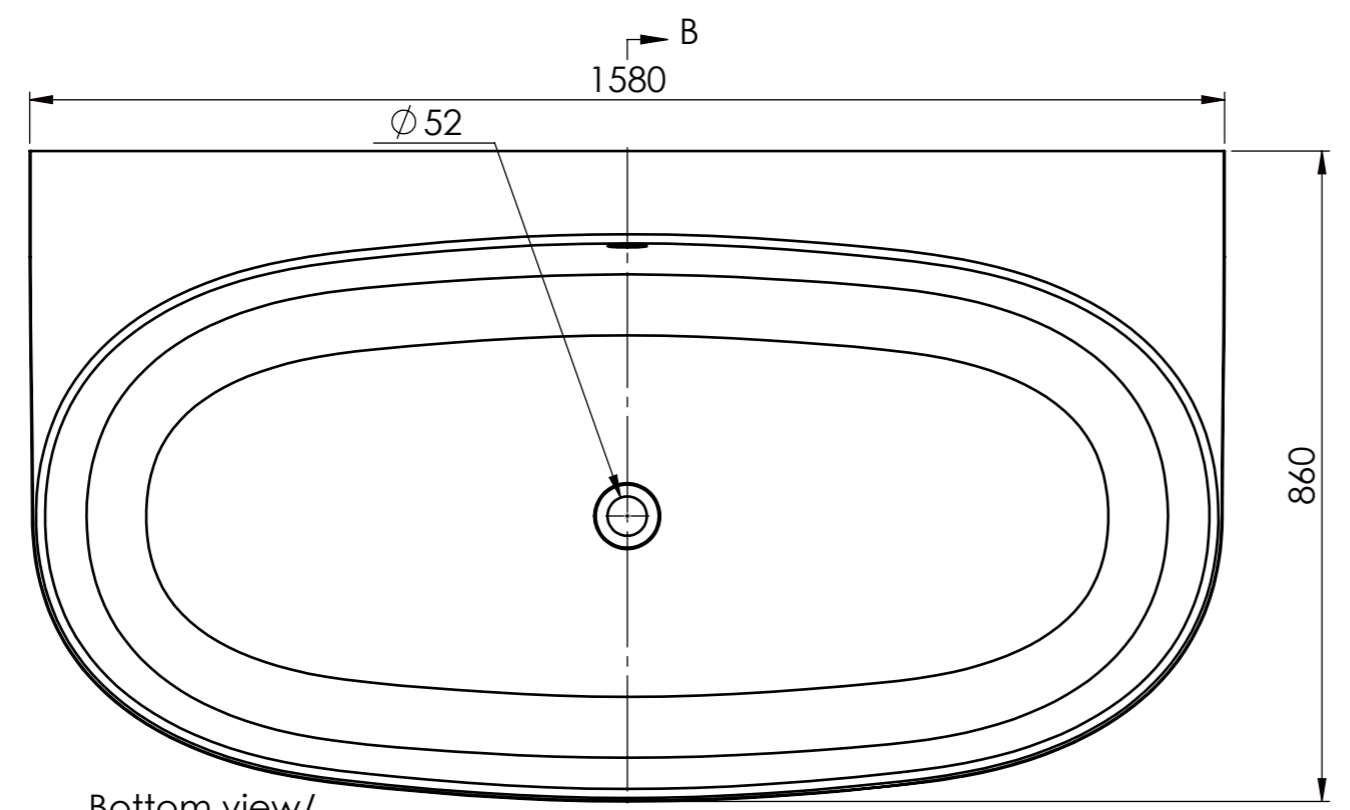
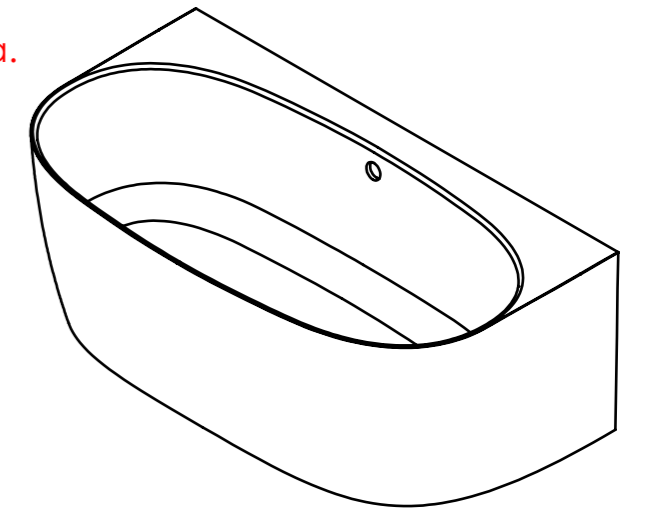
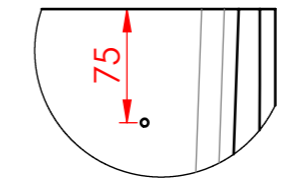

Bottom view/
Widok z dołu

punkty bazowe do
ustawienia odległości obcinania

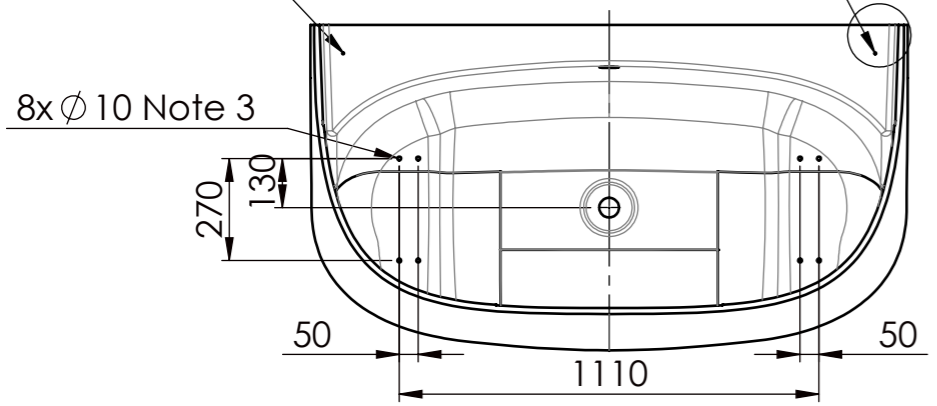

Notes/Uwagi:

1. Water volume (full bathtub) 345 l / objętość wody (pełna wanna) 345 l
2. Water volume (to overflow) 310 l / objętość wody (do przelewu) 310 l
3. M10 steel bearings/M10 kołki stalowe
4. Desing by Marta Gębska

Tolerance length/width/height	+10/-10 mm	Drawn by	Zbigniew P	Created Date	2018-12-12	Checked by	Rafal B
Tol. plane bending	≤800 mm	+1,5/-1,5 mm	Project status	Approved			
	>800 mm	+3/-3 mm	Client	MARMITE			
Tolerance holes location	+3/-3 mm	Art. Name: BT 0052 1580					
Tolerance holes diameter	+1/-1 mm	Art. No: 6312411611xx					
Tolerance wall thickness	+1/-1 mm	Customer ID: STD					
Tolerance feet location	+5/-5 mm	Mould No: F1241161					



Material volume (mm³)	64064565	Overflow	Yes	Taphole	0	Main dimensions L x W / H (mm)	1580 x 860 / 580	Drain	Regular
Surface area (mm²)	6569406	Sheet Size	A3	Scale	1:10	Current revision	001	Sheet	1 \ 1

This document must not be copied without our written permission, and the contents thereof must not be imparted to a third party nor be used for any unauthorized purpose. Contravention will be prosecuted.