



Manual de instructiuni

Instructions manual



RO TRANSPORT / DEPOZITARE / MANIPULARE-MONTARE / INSTALARE-ÎNTREȚINERE:

1. Transportul se face cu mijloace acoperite, curate, cu mijloace adecvate de fixare și protejare a mobilierului de baie, pentru a se evita deteriorarea mobilierului în timpul manipulării și transportului;

2. Mutarea corpurilor de mobilier se face numai prin ridicarea lor; prinderea corpului de mobilier pentru ridicare se face de la bază;



3. Racordarea la rețeaua electrică și apă/canal a mobilierului este obligatorie să fie executată exclusiv de către personal autorizat pentru astfel de operațiuni.

4. În caz de reclamație cumpărătorul va face dovada că instalarea din punct de vedere electric a fost executată de o persoană fizică sau juridică autorizată. În caz contrar, producătorul nu își asumă nici o responsabilitate pentru defectarea mobilierului sau pentru orice alte daune de orice natură provocate de montajul necorespunzător al instalației electrice a mobilierului;



5. Corpurile de mobilier trebuie așezate pe suprafețe orizontale, fără denivelări. Așezarea mobilierului pe suprafețele denivelate creează tensiuni în zonele de îmbinare, ceea ce duce la deformarea corpului sau defectarea mecanismelor de închidere a ușilor și sertarelor. Aceste defecțiuni care pot apărea și în timp nu constituie defecte de fabricație; Nu recomandăm montarea mobilierului deasupra sifonului de pardoseală;



6. Nu așezați pe lavoar obiecte cu greutate totală mai mare de 2-2,5 kg;



7. Nu așezați pe suprafețele mobilei obiecte ude, calde; în caz de stropire cu apă sau diferite substanțe (alcool, ceai, acetonă, tuș etc.) ștergeți imediat cu materiale textile moi, absorbante, foarte puțin umezite. Pe lavoar evitați șocurile termice și metalice;



8. Mobilierul se păstrează numai în încăperi aerisite, ferit de acțiunea radiațiilor solare și de contactul cu apa; Mobilierul este conceput pentru interior;



9. Se recomandă o distanță de minimum 50 cm față de sursele de apă. Evitați contactul direct al mobilierului cu apa. Acesta este conceput să reziste la condiții normale de umiditate (abur, stropire accidentală). Expunerea permanent la un grad ridicat de umiditate va provoca deteriorarea mobilierului (umflare), fapt care nu este acoperit de garanție;



10. Amplasați mobilierul de baie la distanță de sursele de căldură (calorifer, etc.) distanța de gardă generală este de 20 cm, distanța de gardă specială numai pentru mobilierul din lemn este de 30 cm;



11. Se recomandă ștergerea mobilierului de câte ori este nevoie, numai cu materiale moi, uscate și curate. După fiecare utilizare se vor îndepărta urmele de apă în exces sau alte substanțe rămase pe părțile mobilierului/lavoarului numai cu o cârpă moale și uscată. Urmele de grăsimi sau lichide se șterg imediat cu o cârpă uscată;

12. Pentru întreținerea componentelor metalice, mânerelor și feroneriei se va evita utilizarea de produse abrazive (bureți aspri, solvenți, diluanți etc.);

13. Se recomandă verificarea periodică a instalației sanitare aferente mobilierului de baie pentru a evita eventualele pierderi de apă care ar putea duce în timp la deteriorarea mobilierului.

EN TRANSPORT / STORAGE / HANDLING-ASSEMBLY / INSTALLATION-MAINTENANCE:

1. The transport shall occur in covered and clean vehicles, provided with adequate fastening and protection elements, in order to avoid the damaging of the bathroom furniture during the handling and transportation;

2. Furniture pieces shall be moved only by lifting; the furniture piece shall be grabbed from the base;



3. The connection of the furniture to the power and water supply networks and to the sewage shall be performed exclusively by qualified staff.

4. In case of complaints, the purchaser shall provide evidence of the fact that the electrical installation has been carried out by an authorized individual or company. Anything to the contrary shall exempt the manufacturer from its liability for defects or any other damages caused by the improper execution of the power supply installation;



5. The furniture pieces must be placed on even horizontal surfaces. Placing the furniture on uneven surfaces leads to stresses in the jointing areas, which causes deformation or damages the door or drawer closing mechanisms. Such defects may also occur in time and do not represent manufacturing defects; we advise against the assembly of the furniture above the floor trap;



6. Do not place objects heavier than 2-2.5 kg on the sink cabinet;



7. Do not place wet, warm objects onto the furniture surface; if the furniture is splashed with water or other substances (alcohol, tea, acetone, ink, etc) immediate wipe it with a soft, absorbent and slightly damp cloth. Do not expose the sink cabinet to thermal or metallic shocks.



8. The furniture shall be kept exclusively in ventilated rooms, protected against sun rays and water; the furniture is designed for interior use;



9. A minimum distance of 50 cm to the water sources is recommended. Avoid direct contact with water. The furniture is manufactured to resist under normal humidity conditions (steam, accidental splashing). Permanent exposure to a high level of humidity will damage the furniture (swelling), a situation not covered by the warranty;



10. Place the bathroom furniture away from heat sources (radiator, etc.), the usual safe distance being 20 cm, and the special safe distance (for wood furniture) being 30 cm;



11. It is recommended that you wipe the furniture as required, with a soft, dry and clean cloth. After every use, wipe any traces of excess water or other residues on the furniture/sink cabinet only with a soft and dry cloth. Grease or liquid is to be immediately wiped with the dry cloth;

12. For the maintenance of metal parts, such as handles and fittings, avoid the use of corrosive products (rough sponge, solvents, paint thinners, etc.);

13. It is recommended that you regularly check the sanitary installation related to the bathroom furniture in order to prevent any water leakages that might damage the furniture in time.

IT TRASPORTO / DEPOSITO / MOVIMENTAZIONE-MONTAGGIO / INSTALLAZIONE-MANUTENZIONE:

1. Il trasporto avviene con mezzi coperti, puliti, con adeguati mezzi di fissaggio e di protezione dei mobili da bagno, per evitare il danneggiamento dei mobili durante la movimentazione e il trasporto;

2. Lo spostamento dei mobili viene effettuato solo tramite il loro sollevamento; la cattura del mobile per sollevare avviene dalla base;



3. Il collegamento alla rete elettrica e acqua/fogna dei mobili sarà obbligatoriamente eseguito esclusivamente da personale autorizzato per tali operazioni;

4. In caso di reclamo, l'acquirente dovrà dimostrare che l'installazione dal punto di vista elettrico è stata eseguita da una persona fisica o giuridica autorizzata. Altrimenti, il produttore non assume alcuna responsabilità per danni ai mobili o per qualsiasi altri danni di qualsiasi altra natura causati dal montaggio improprio dei mobili all'impianto elettrico;



5. I corpi di mobili devono essere posizionati su superfici orizzontali, senza urti. Il posizionamento dei mobili su superfici irregolari crea tensioni nelle zone di abbinamento, con conseguente deformazione del corpo o il guasto dei meccanismi di chiusura delle ante e dei cassetti. Questi guasti che possono sorgere anche in tempo non sono considerati difetti di produzione. Si consiglia di non assemblare i mobili sul sifone di pavimento;



6. Non collocare su lavandino oggetti di peso totale di oltre 2-2,5 kg;



7. Non collocare sulle superfici dei mobili oggetti bagnati, caldi; in caso di spruzzata d'acqua o di varie sostanze (alcol, tè, acetone, inchiostro, ecc.) pulite immediatamente con materiali tessili, morbidi, assorbenti, leggermente inumiditi. Su lavandino evitate gli shock termici e metallici;



8. I mobili vengono conservati solo in locali ventilati, fuori dall'azione delle radiazioni solari e dal contatto con acqua; L'arredamento è progettato per interno;



9. Si consiglia una distanza minima di 50 cm da fonti di acqua. Evitate il contatto diretto dell'arredo con l'acqua. Questo è stato progettato per resistere a condizioni normali di umidità (vapore, spruzzi accidentali). L'esposizione permanente ad un alto grado di umidità causerà il deterioramento dei mobili (gonfiore), che non è coperto dalla garanzia;

10. Posizionate il mobile da bagno lontano da fonti di calore (calorifero, ecc.), distanza di guardia generale è di 20 cm, distanza di guardia speciale soltanto per i mobili in legno è di 30 cm;



11. Si consiglia di pulire i mobili ogniqualvolta sia necessario, solo con materiali morbidi, asciutti e puliti. Dopo ogni utilizzo si pulisce ogni eccesso di acqua o altre sostanze restanti sulle parti dei mobili / lavandino solo con un panno morbido e asciutto. Le tracce di grasso o di liquido sono pulite con un straccio asciutto;

12. Per la manutenzione dei componenti metallici, delle maniglie e della ferramenta sarà evitato l'uso di prodotti abrasivi (spugne ruvide, solventi, diluenti, ecc.);

13. Si consiglia di verificare periodicamente l'impianto idraulico dei mobili da bagno per evitare eventuali perdite di acqua che potrebbero portare nel tempo al deterioramento dei mobili.

HU SZÁLLÍTÁS / TÁROLÁS / MOZGATÁS-ÖSSZESZERELÉS / BEÉPÍTÉS-KARBANTARTÁS:

1. A szállítást letakarva, tiszta szállítóeszközön, megfelelő rögzítéssel és a fürdőszobai bútort megfelelő védelemmel ellátva szabad kivitelezni, hogy megelőzzék a fürdőszobai bútor szállítás és mozgatás közbeni károsodását;

2. A bútorelemek mozgatása csak felemeléssel történhet, a bútordarab felemelésekor azt az alapzatnál kell megfogni;



3. A bútordarab csatlakoztatását az elektromos és víz-/szennyvízhálózatra kizárólag szakképzett személyzet végezheti el.
4. Panasz benyújtása esetén a vásárlónak igazolnia kell, hogy az elektromos csatlakoztatást szakengedéllyel rendelkező cég vagy egyéni vállalkozó végezte el. Ellenkező esetben a gyártó nem vállalja a felelősséget a bútordarab károsodásáért vagy bármilyen más jellegű, a nem megfelelő elektromos csatlakoztatás által okozott hibákért.



5. A bútordarabokat vízszintes, egyenletes felületre kell elhelyezni. Ha a bútordarabot egyenetlen felületre helyezik el, feszültség alakulhat ki az illesztési pontoknál, ami a darab torzulásához vagy a nyílászárók és fiókok záró rendszereinek meghibásodásához vezethet. Ezek a használat során is megjelenő meghibásodások nem tekintendők gyártási hibának; Nem javasoljuk a bútordarab felszerelését a padlóban található lefolyó fölé;



6. Ne helyezzen a mosdóra olyan tárgyakat, amelyeknek az összsúlya meghaladja a 2–2,5 kg-ot;



7. Ne helyezzen a bútor felületére vizes vagy meleg tárgyakat; amennyiben összevizezte vagy más anyaggal (alkohol, tea, aceton, tus stb.) szennyezte a felületét, törölje le azonnal puha, nedvszívó, enyhén megnedvesített anyaggal. Vigyázzon, hogy a mosdót ne érje erős hőhatás vagy fémes tárgy;



9. Javasoljuk a vízforrástól min. 50 cm távolságra való elhelyezését. Vigyázzon arra, hogy a bútordarab ne érintkezzen közvetlenül a vízzel. A bútordarab úgy van kialakítva, hogy ellenálljon a normál nedvességnek (pára, véletlenszerű lecsepegtetés). A magas páratartalomnak való hosszantartó kitettség a bútordarab károsodását okozhatja (felhólyagosodás), ezt a garancia nem fedezi;



10. A fürdőszobai bútort helyezze távol a hőforrásoktól (fűtőtest stb.), az általános biztonsági távolság 20 cm, csak a fabútor esetén a speciális biztonsági távolság 30 cm.



11. Ajánlott a bútor igény szerinti törlése, csak puha, száraz és tiszta textíliával. Minden használat után le kell törölni a vizet, illetve a bútorzaton/mosdón maradt egyéb anyagokat kizárólag puha és száraz törleronggyal. A folyadék- vagy zsíradékcseppeket azonnal le kell törölni egy száraz rongy segítségével;

12. A fémes alkotóelemek, fogantyúk és vasalat karbantartásakor kerülni kell a dörzshatású tisztítószer használata (durva szivacsok, oldószerek, higítók stb.);

13. Ajánlott a fürdőszobai bútorhoz tartozó vízhálózat rendszeres ellenőrzése a vízszivárgás megelőzése érdekében, mivel a szivárgó víz idővel károsíthatja a bútort.

GR ΜΕΤΑΦΟΡΑ / ΑΠΟΘΗΚΕΥΣΗ / ΔΙΑΧΕΙΡΙΣΗ - ΤΟΠΟΘΕΤΗΣΗ / ΕΓΚΑΤΑΣΤΑΣΗ-ΣΥΝΤΗΡΗΣΗ:

1. Η μεταφορά πραγματοποιείται με κλειστά και καθαρά μέσα μεταφοράς, που διαθέτουν τα κατάλληλα μέσα στερέωσης και προστασίας των επίπλων μπάνιου, για την αποφυγή τυχόν ζημιών κατά το χειρισμό και τη μεταφορά των επίπλων.

2. Προκειμένου να μετακινήσετε τα έπιπλα, σηκώστε τα, πιάνοντας τα από τη βάση.



3. Η διασύνδεση των επίπλων στο ηλεκτρικό δίκτυο και στο δίκτυο ύδρευσης και αποχέτευσης θα πραγματοποιείται αποκλειστικά από προσωπικό εγκεκριμένο για τέτοιες εργασίες.

4. Σε περίπτωση καταγγελίας, ο αγοραστής θα πρέπει να αποδείξει ότι η ηλεκτρική εγκατάσταση πραγματοποιήθηκε από εγκεκριμένο φυσικό ή νομικό πρόσωπο. Σε αντίθετη περίπτωση, ο κατασκευαστής δεν αναλαμβάνει καμία ευθύνη για τις ζημιές στα έπιπλα ή για οποιεσδήποτε άλλες ζημιές οποιουδήποτε είδους που προκλήθηκαν από λανθασμένη τοποθέτηση της ηλεκτρικής εγκατάστασης των επίπλων.



5. Τα έπιπλα πρέπει να τοποθετούνται σε οριζόντιες ομοιόμορφες επιφάνειες. Η τοποθέτηση επίπλων σε ανισόπεδες επιφάνειες δημιουργεί εντάσεις στις αρθρώσεις, πράγμα το οποίο οδηγεί στην παραμόρφωση του επίπλου ή την ελαττωματική λειτουργία των μηχανισμών κλεισίματος των πορτών και των συρταριών. Αυτές οι βλάβες, που μπορεί να προκύψουν και με την πάροδο του χρόνου, δεν αποτελούν κατασκευαστικά ελαττώματα. Αποτρέπουμε την τοποθέτηση του επίπλου πάνω στο σιφόνι του πατώματος.



6. Μην τοποθετείτε στον νιπτήρα αντικείμενα με συνολικό βάρος μεγαλύτερο των 2-2,5 κιλών.



7. Μην τοποθετείτε στην επιφάνεια του επίπλου βρεγμένα και ζεστά αντικείμενα. Σε περίπτωση που το έπιπλο βραχεί με νερό ή διάφορες ουσίες (αλκοόλ, τσάι, ακετόνη, μελάνι, κλπ), σκουπίστε αμέσως με ένα πανί μαλακό, απορροφητικό, ελαφρώς βρεγμένο. Αποφεύγετε τα θερμικά και μεταλλικά σοκ στον νιπτήρα.



8. Τα έπιπλα διατηρούνται μόνο σε αεριζόμενους χώρους, μακριά από τη δράση της ηλιακής ακτινοβολίας και την επαφή με το νερό. Τα έπιπλα είναι σχεδιασμένα για εσωτερικούς χώρους.



9. Συνιστάται μια ελάχιστη απόσταση 50 εκατοστών από τις πηγές νερού. Αποφεύγετε την άμεση επαφή των επίπλων με το νερό. Τα έπιπλα είναι σχεδιασμένα να αντέχουν σε κανονικές συνθήκες υγρασίας (ατμός, τυχαίος ψεκασμός). Η μόνιμη έκθεση σε υψηλή υγρασία θα προκαλέσει ζημιά στα έπιπλα (πρήξιμο), περίπτωση που δεν καλύπτεται από την εγγύηση.



10. Τοποθετήστε τα έπιπλα μπάνιου μακριά από πηγές θερμότητας (καλοριφέρ, κλπ.). Η γενική απόσταση ασφαλείας είναι 20 εκ, η ειδική απόσταση ασφαλείας μόνο για τα ξύλινα έπιπλα είναι 30 εκ.



11. Συνιστάται το σκούπισμα των επίπλων εφόσον αυτό είναι αναγκαίο, μόνο με την χρήση μαλακών, στεγνών και καθαρών υφασμάτων. Μετά από κάθε χρήση, θα απομακρυνθεί η ενδεχόμενη περίσσεια νερού ή άλλων ουσιών από τις πλευρές του επίπλου / νιπτήρα με ένα μαλακό και στεγνό πανί. Τα ίχνη λίπους ή υγρού πρέπει να σκουπιστούν αμέσως με στεγνό πανί.

12. Για τη συντήρηση των μεταλλικών εξαρτημάτων, των λαβών και των σιδερικών, αποφεύγετε τη χρήση λειαντικών προϊόντων (σκληρών σφουγγαριών, διαλυτών, αραιωτικών, κλπ.)

13. Συνιστάται περιοδικός έλεγχος της υδραυλικής εγκατάστασης των επίπλων για να αποφευχθούν τυχόν διαρροές νερού που θα μπορούσαν να προκαλέσουν, με τον καιρό, ζημιές στα έπιπλα.

ВГ ТРАНСПОРТ / СЪХРАНЕНИЕ / МАНИПУЛИРАНЕ / МОНТАЖ-ПОДДРЪЖКА:

1. Транспортът се извършва чрез покрити, чисти превозни средства, с подходящо закрепване и предпазване на мебелите за баня, за да се избегнат повреди по време на работа и транспорт;

2. Преместването на мебелите се извършва само чрез повдигането им; хващането на мебелното тяло е в основата;



3. Свързването на изделието към ел. мрежата и ВиК е задължително да бъде изпълнено само от персонал, оторизиран за такива операции.

4. В случай на рекламация, купувачът трябва да докаже, че инсталирането от електрическа гледна точка е извършено от упълномощено физическо или юридическо лице. В противен случай, производителят не поема отговорност за повреждането на мебелите или други щети от всякакъв вид, причинени от неправилен монтаж на ел. инсталацията на мебелите;



5. Мебелните тела трябва да бъдат поставени върху хоризонтални повърхности, без неравности. Поставянето на мебели по неравни повърхности създава напрежение в зоните на съединяване, което води до деформация на тялото или механизмите за затваряне на вратите и чекмеджетата. Тези грешки, които могат да възникнат и във времето не представляват производствени дефекти; Не препоръчваме монтиране на мебелите над сифона на пода;



6. Не поставяйте върху мивката предмети с общо тегло повече от 2-2,5 кг;



7. Не поставяйте върху повърхностите на мебелите влажни, топли предмети; при напръскване с вода или различни вещества (алкохол, чай, ацетон, туш и др.), веднага избършете с меки кърпи, абсорбиращи, леко навлажнени. Избягвайте термични и метални удари по мивката;



8. Мебелите се съхраняват само в проветливи помещения, далеч от действието на слънчевата светлина и контакт с вода; Мебелите са предназначени за интериор;



9. Препоръчва се минимално разстояние от 50 см от източници на вода. Да се избягва пряк контакт на мебелите с вода. Те са предназначени да издържат на нормални условия на влажност (пара, случайно пръскане). Постоянното излагане на висока влажност може да доведе до увреждане на мебелите (подуване). Това не се покрива от гаранцията;



10. Поставяйте мебелите за баня далеч от източници на топлина (радиатори и др.), обичайното предпазно разстояние е 20 см, специалното предпазно разстояние само за дървени мебели е 30 см;



11. Препоръчва се забърсването на мебелите, когато е необходимо, само с меки кърпи, сухи и чисти. След всяка употреба да се премахне излишната вода или други вещества, останали по частите на мебелите / мивката само с мека суха кърпа. Следи от мазнина или течност, се почистват веднага със суха кърпа;

12. За поддържане на металните компоненти, дръжките и железните елементи, да се избягва използването на абразивни продукти (груби гъби, разтворители, разредители и др.);

13. Препоръчва се периодично проверяване на санитарната инсталация, свързана с мебелите за баня, за да се избегнат евентуални водни течове, които биха могли да доведат до преждевременно увреждане на мебелите.

SL PREVOZ / SKLADIŠČENJE / RAVNANJE-MONTAŽA / NAMESTITEV-VZRŽEVANJE:

1. Prevoz se izvede s pokritimi, čistimi sredstvi, z ustreznimi sredstvi za fiksiranje in varovanje kopalniškega pohištva, da bi se preprečilo poškodovanje pohištva med ravnanjem in prevozom;

2. Premikanje pohištva se izvede samo z dvigom izdelkov; oprijem pohištva za dviganje se naredi od baze izdelka;



3. Povezavo na električno in vodno/kanalizacijsko mrežo lahko izvaja izključno osebje, ki je pooblaščen za takšne postopke.

4. V primeru reklamacije bo kupec dokazal, da je bila električna namestitev opravljena s strani pooblaščenega fizične ali pravne osebe. V nasprotnem primeru, proizvajalec ne prevzema nobene odgovornosti za poškodbe pohištva ali za katere koli druge poškodbe zaradi neustrezne montaže električne instalacije pohištva;



5. Pohištvo je treba postaviti na vodoravno površino, brez grbin. Postavitev pohištva na neravni površini ustvarja napetosti v sklepnih conah, kar vodi do deformiranja izdelka ali poškodovanja mehanizmov za zapiranje vrat ali predalov. Te napake se lahko pojavijo in sčasoma ne predstavljajo tovarniških napak; Ne priporočamo montaže pohištva nad talnim odtokom;



6. Na umivalnik ne postavljajte izdelkov, ki tehtajo več kot 2-2,5 kg;



7. Na površine pohištva ne postavljajte mokrih, vročih izdelkov; v primeru brizganja z vodo ali drugimi snovi (alkoholom, čajem, acetonom, črnilom itd.) takoj obrišite z mehкими, vpojnimi, rahlo navlaženimi tekstilnimi materiali. Izogibajte se toplotnim in kovinskim šokom na umivalniku;



8. Pohištvo shranjujte le v prezračevanih prostorjih, ki so zaščiteni pred sončnim sevanjem in stikom z vodo; Pohištvo je zasnovano za notranjo uporabo;



9. Priporočljiva je najmanjša razdalja 50 cm od vodnih virov. Izogibajte se neposrednemu stiku pohištva z vodo.

Zasnovano je, da zdrži na normalne pogoje vlage (par, škropljenju po naključju). Stalna izpostavljenost na visoki vlažnosti bi povzročila poškodovanje pohištva (otekanje), kar ni zajeto v garanciji;









10. Postavite kopalniško pohištvo stran od virov toplote (radiatorjev itd.) splošna razdalja je 20 cm, posebna razdalja je pa 30 cm za leseno pohištvo;

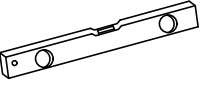
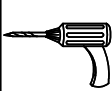

11. Priporočljivo je brisanje pohištva kadar je to potrebno, samo z mehкими, suhimi in čistimi materiali. Po vsaki uporabi je treba odstraniti odvečno vodo ali druge snovi, preostale na delih pohištva/umivalnika samo z mehko in suho krpo. Sledi maščobe ali tekočine se takoj izbršijo z mehko krpo;

12. Za vzdrževanje kovinskih komponent, ročajev in strojne opreme se je treba izogniti uporabi brusilnih izdelkov (grobih gobic, topil, redčil itd.);

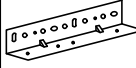
13. Priporoča se periodično preverjanje sanitarne instalacije, ustrezne kopalniškemu pohištvu, da ne pride do morebitnih puščanj vode, ki bi lahko sčasoma vodila do poškodovanja pohištva;

REQUIRED					SILICONE 		INCLUDED  A x 1	3.5x16  B x 2
----------	---	---	---	---	---	--	--	--

1

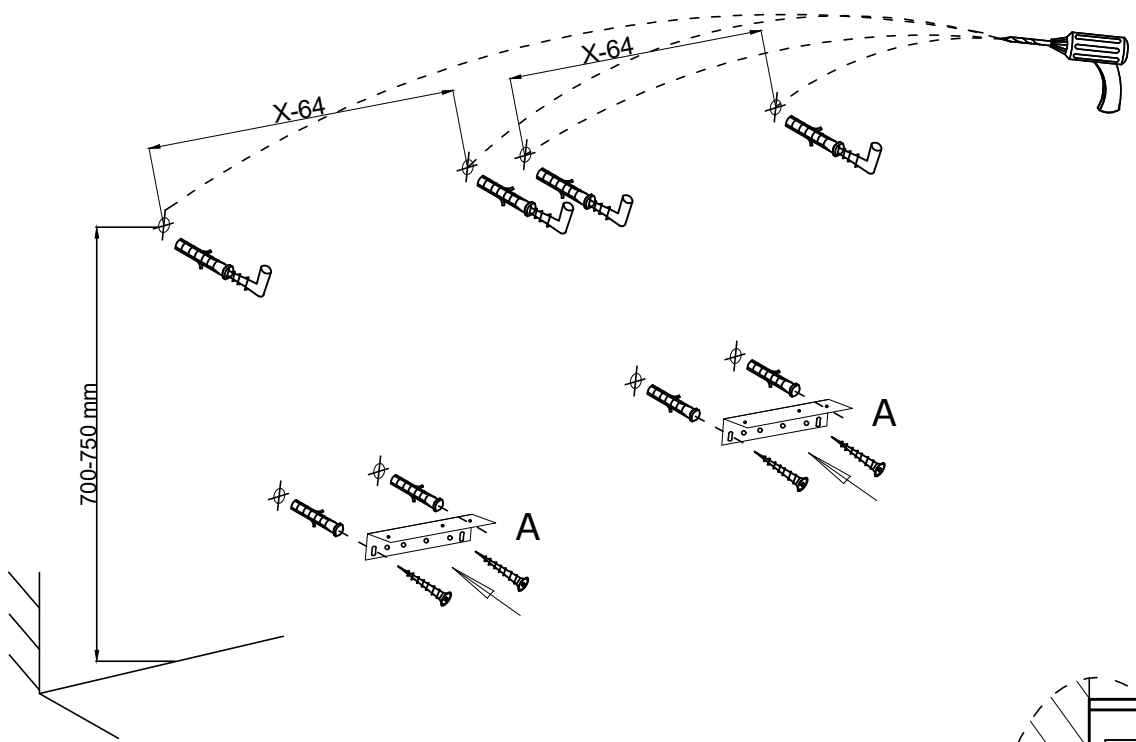

2

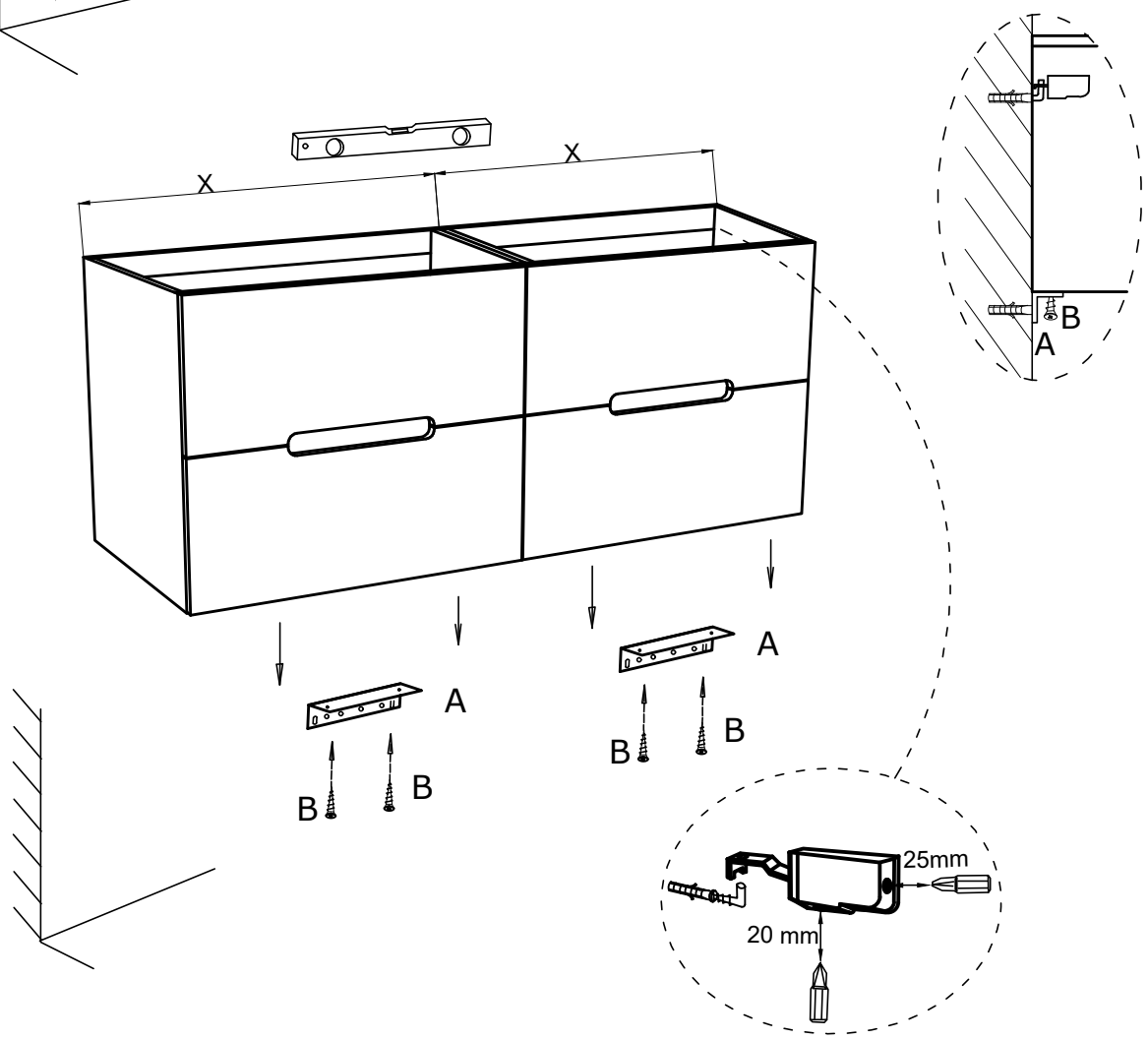

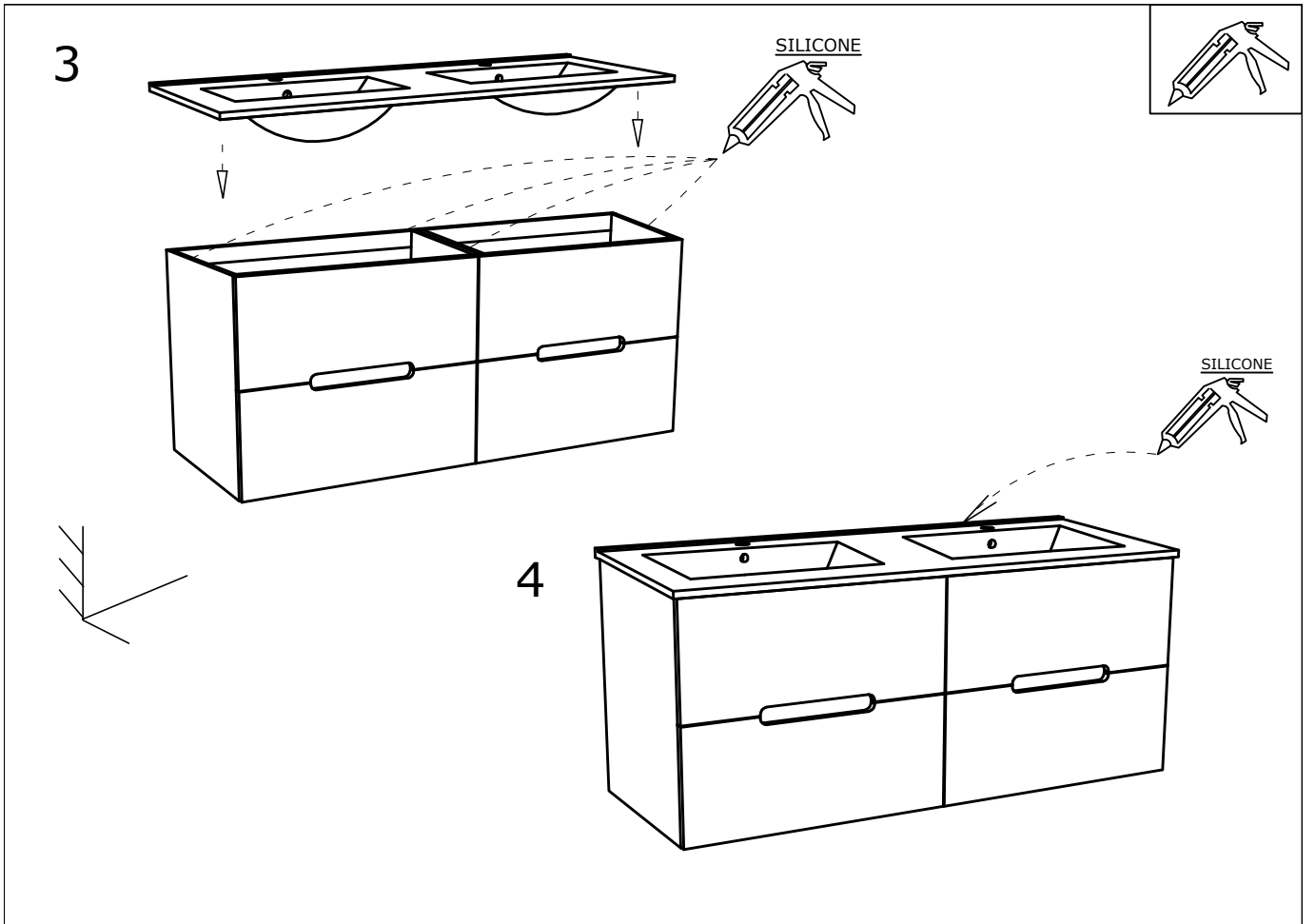

REQUERIDO					INCLUIDO		
						A x 2	B x 4

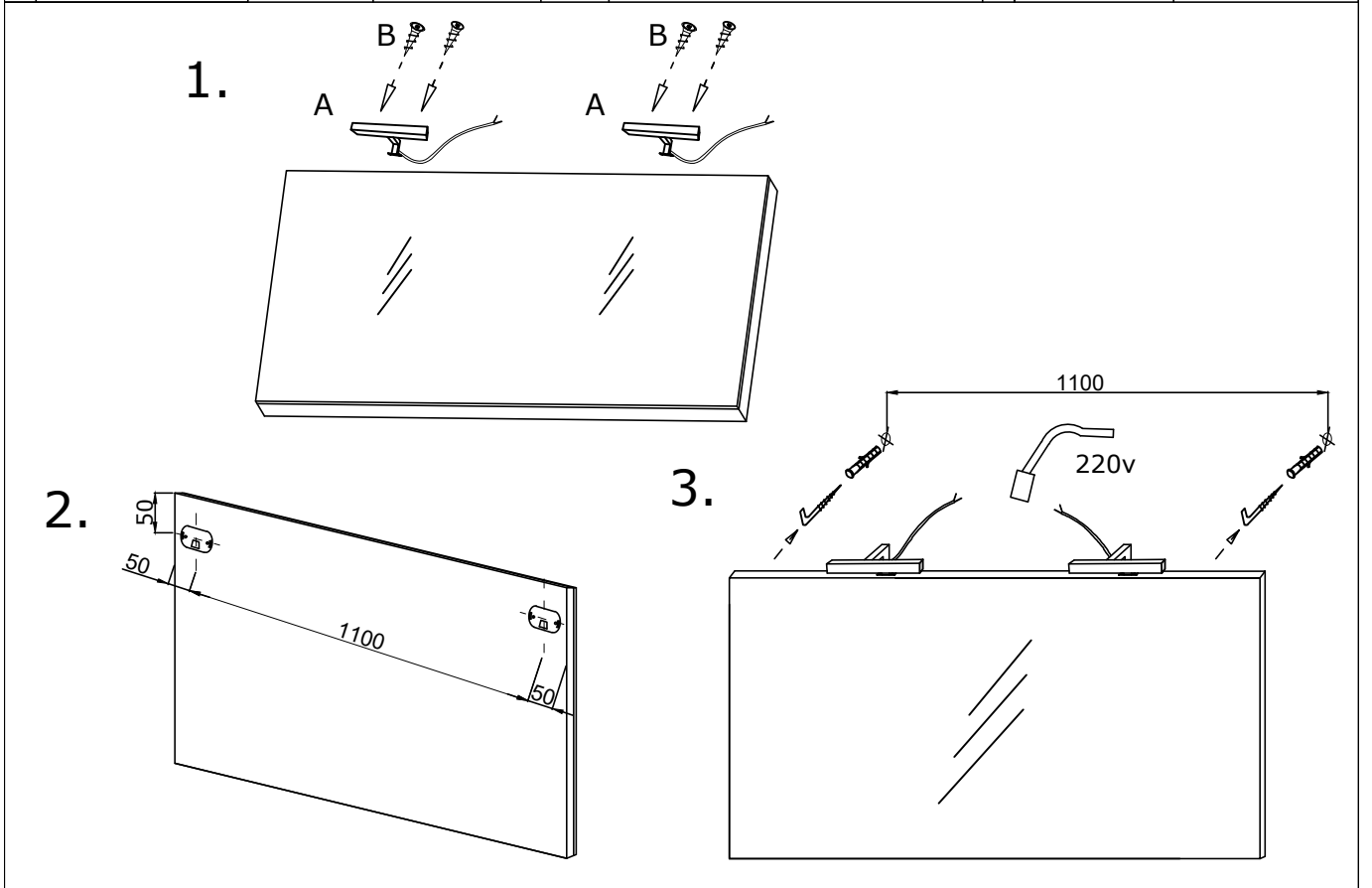

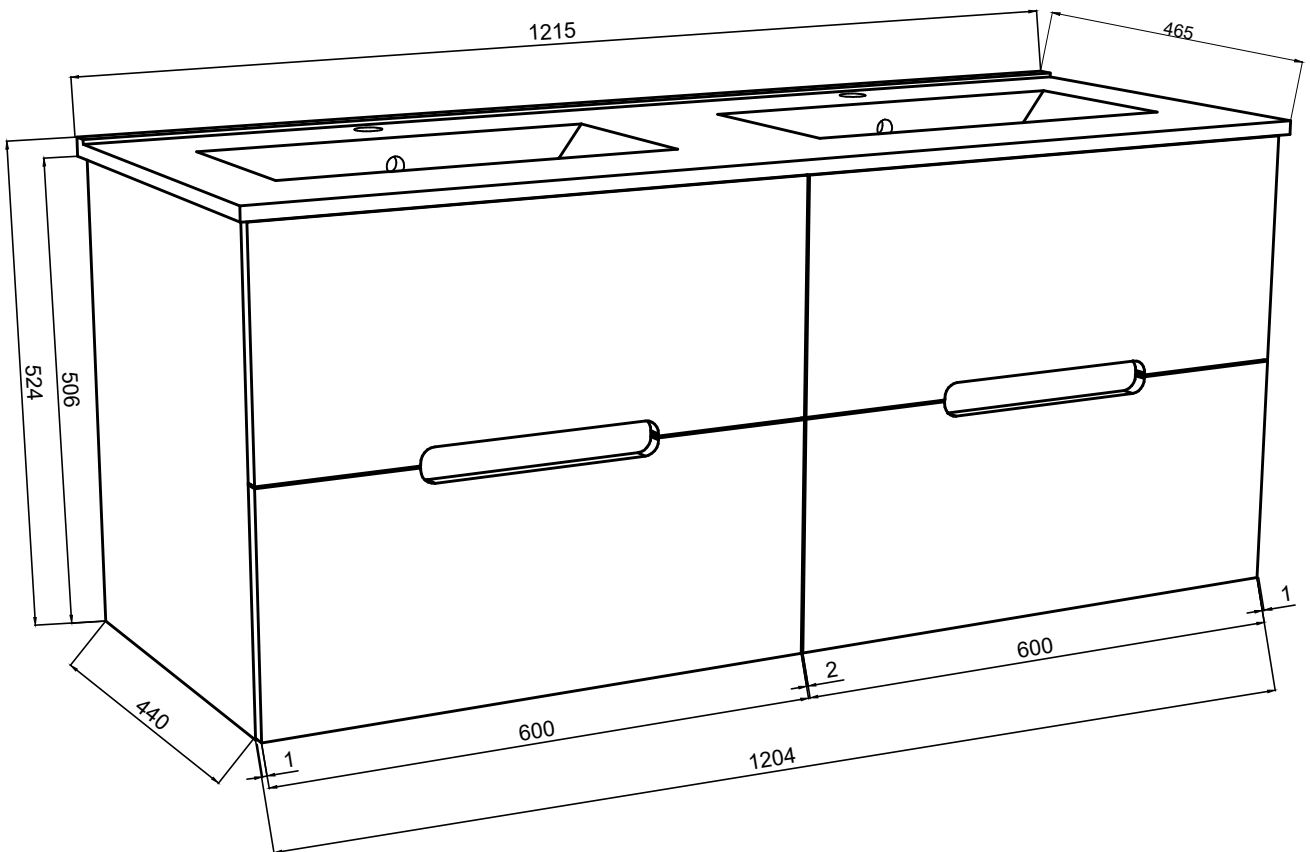
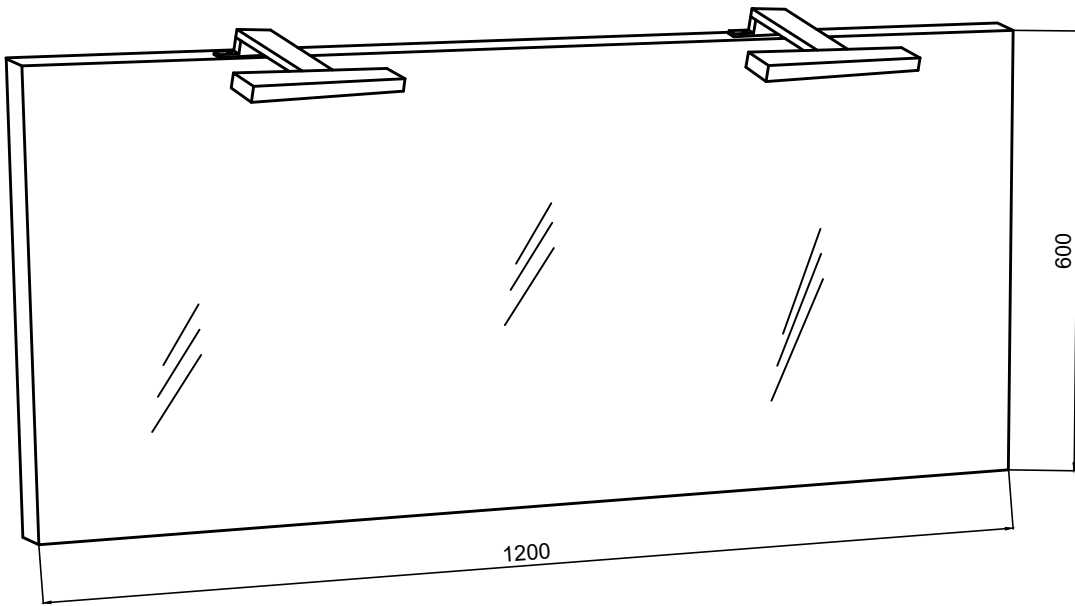

IRIS120

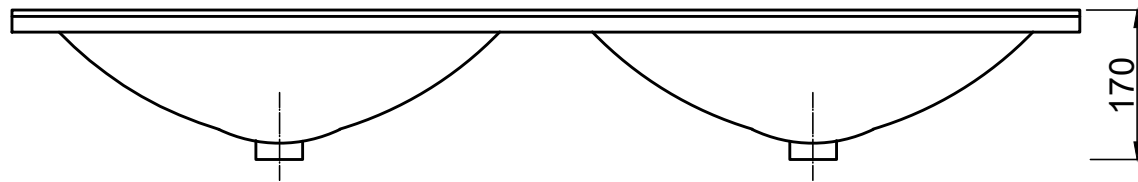
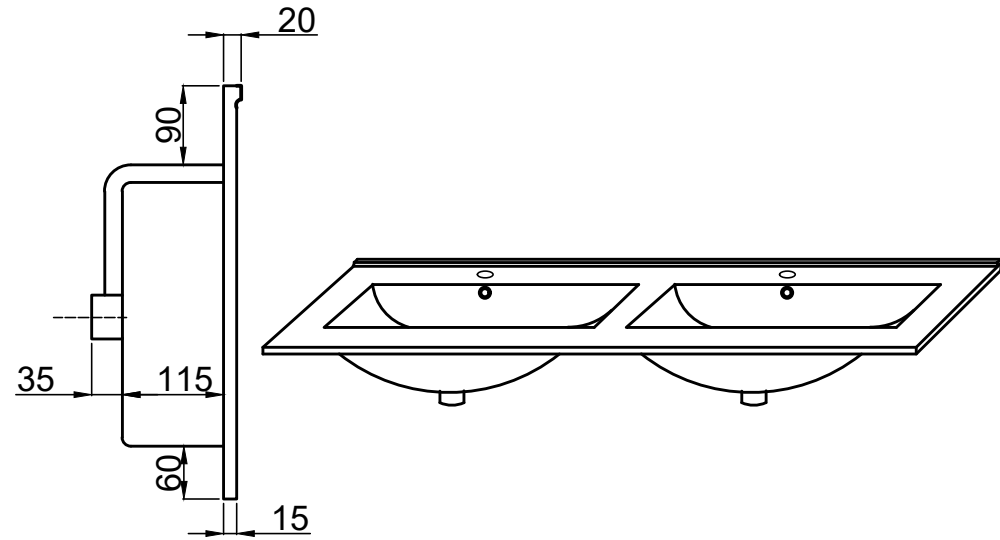
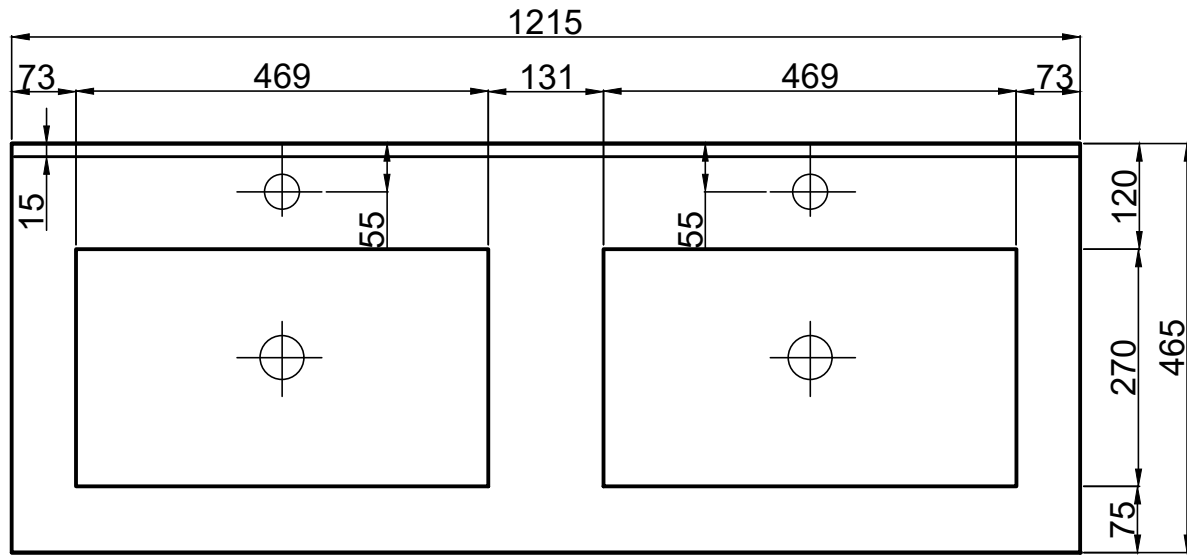

LAVABO QUADRO 1215X465X170

T lunghezza = ± 5 mm

T spessore = ± 2 mm

T planarita = ± 2 mm