

ACQUA REFRIGERATA ZINCATO ZB VT

VERTICAL GALVANIZED CHILLED WATER TANK

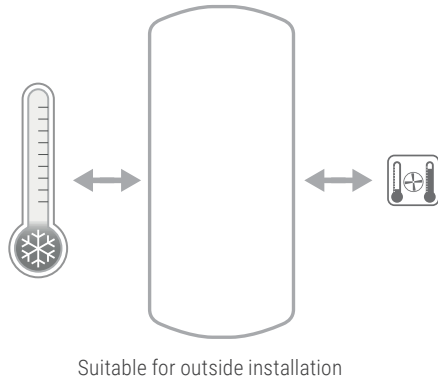

Suitable for outside installation

PRESSURE	TEMPERATURE
Pmax 6 bar	Tmax -10 / +60 °C



APPLICATION AND TECHNICAL DESCRIPTION

Storage of chilled water for Air Conditioning installations. These buffer are with hard box insulation and an external lining with a galvanized and painted plate.

They are used for air conditioning installations in order to increase the thermal inertia and, for those installations without a low water-capacity, avoiding that the chilling generator is continually working.

EXTERNAL LINING

Galvanized and painted metallic cover.

MATERIAL

These tanks are galvanized inside and outside, with immersion in a pool of fused zinc with pureness not below 99,99% (Uni EN 1179).

INSULATION

High thermal insulation with ecological hard polyurethane foam.

WARRANTY

2 years

See general sales conditions and warranty.

Model	ACQ. REF. ZB VT (BOX INSULATION) Art. Nr.
100	3001162310001
200	3001162310002
300	3001162310003
500	3001162310004
800	3001162310005
1000	3001162310006
1500	3001162310007
2000	3001162310008



SUITABLE FOR OUTSIDE INSTALLATION

- 1 Drain
- 2 Safety Valve
- 3-4-5-6 To the System
- 7-8 Connection for Instrumentation 1/2" Gas F

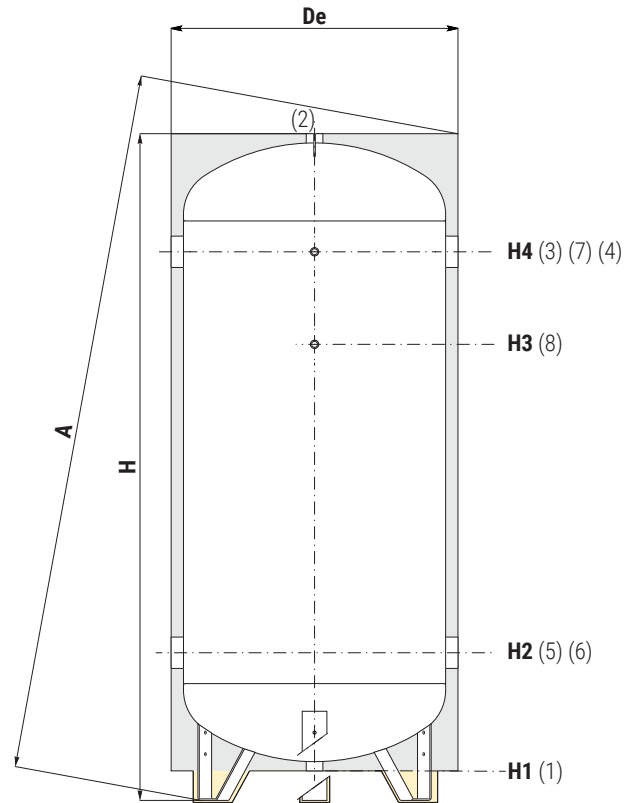

Model	Weight [Kg]	Volume [litres]	De	H	A	H1	H2	H3	H4	1 2	5-6-3-4	7-8
Connections Gas F												
100	32	101	460	1006	1017	73	287	592	792	1"1/4	1"1/2	1/2"
200	53	190	510	1407	1415	68	297	927	1177	1"1/4	1"1/2	1/2"
300	67	292	610	1518	1529	129	404	994	1244	1"1/4	2"	1/2"
500	101	501	710	1810	1821	121	441	1241	1491	1"1/4	3"	1/2"
800	147	788	810	2108	2119	108	458	1458	1758	1"1/4	3"	1/2"
1000	170	1034	930	2162	2178	96	479	1479	1779	1"1/2	3"	1/2"
1500	183	1432	1010	2351	2386	102	471	1681	1981	2"	3"	1/2"
2000	219	1970	1170	2421	2437	102	506	1716	2016	2"	3"	1/2"

P.E.D. product designed and produced in conformity to the article 4.3 of directive 2014/68/UE - ErP Ecodesign directive 2009/125/CE

EXTRA-BOLLY®
CALORIFIERS

BOLLYTERM®
CALORIFIERS

STAINLESS STEEL
CALORIFIERS

CALORIFIERS FOR
HEAT PUMP

MULTIFUEL ENERGY
CYLINDERS - PUFFER

HYDRONIC

INERTIAL
TANKS

WATER PRESSURE
TANKS

COMPRESSED AIR
RECEIVERS

ACCESSORIES
AND SPARE PARTS

TECHNICAL
SUPPORT