

TECHNICAL NOTE



COMMANDS AND CONTROLS FAN COILS

Controls and controls for fan coil units and terminal units:
BRIO-I SLIM - YARDY EV3 - YARDY-I EV3 - YARDY DUCT2
YARDY ID2- YARDY HP - DIVA - DIVA-I



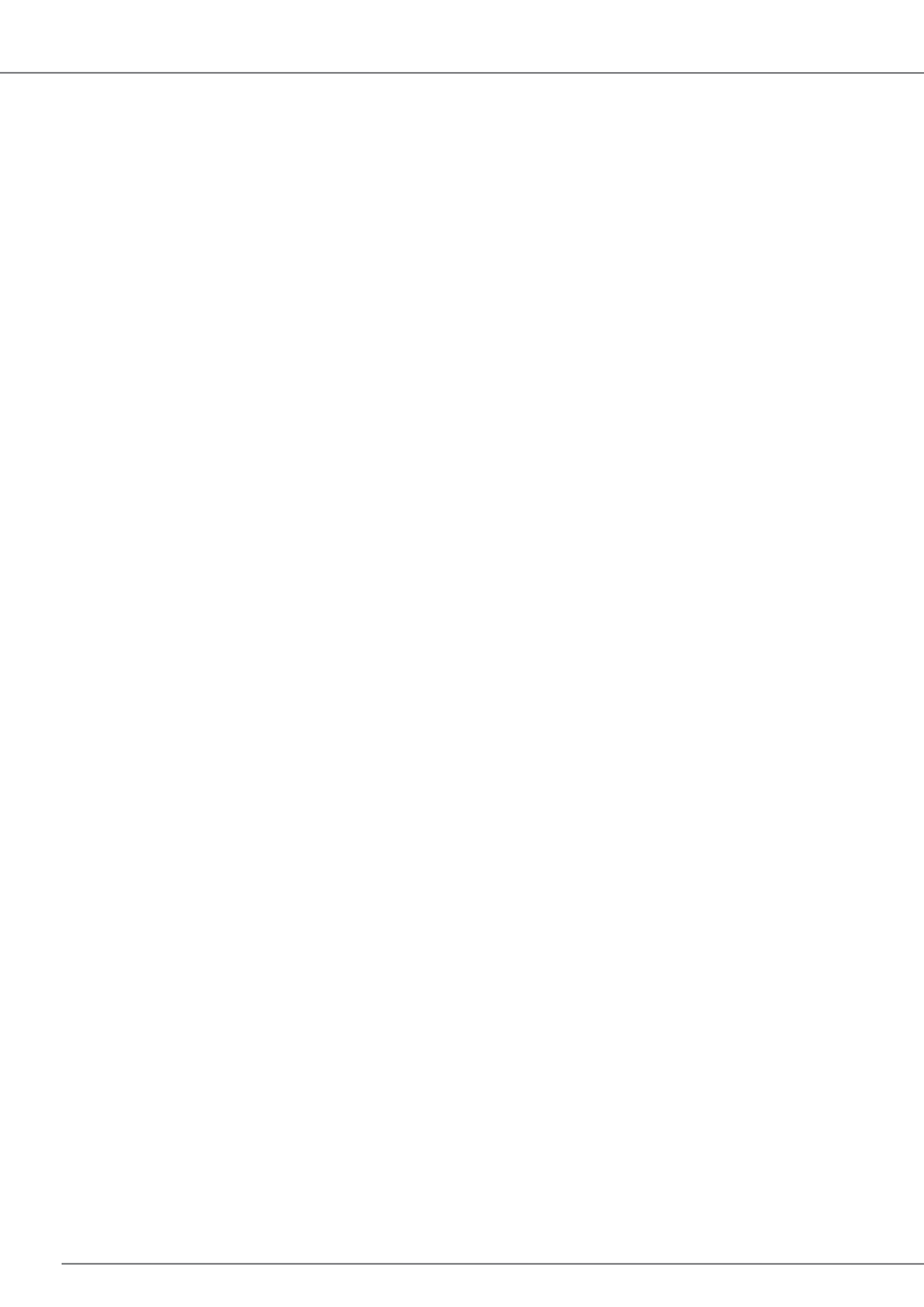

1. TABELLA RIEPILOGATIVA CONTROLLI	4
1.1 Standard controls	4
1.2 Advanced controls LIT-TOUCH	5
2. FUNCTIONS STANDARD CONTROLS	6
2.1 Standard controls	6
2.2 Features standard checks	7
3. FUNCTIONS LIT-TOUCH ADVANCED CONTROLS	9
3.1 Advanced controls LIT-TOUCH	9
3.2 Features LIT-TOUCH advanced controls	10
3.3 Dimensions	11
4. FUNCTIONS STANDARD CONTROLS AND SLIM-TOUCH CONTROLS	14
4.1 SLIM-TOUCH Advanced controls	14
4.2 Standard controls	14
4.3 SLIM-TOUCH advanced controls features	15
5. SPECIFICATIONS OF CHECKS	17
5.1 Specifications of standard checks	17
5.2 Specifications of LIT-TOUCH evolved controls	17
5.3 Specifications of SLIM-TOUCH evolved controls	17
6. ELECTRICAL CONNECTION OF THE UNITS	18
6.1 Standard controls	18
6.2 Advanced controls LIT-TOUCH	29
7. DIVA - DIVA-I CONNECTION	37
8. CONNECTION DIAGRAMS BRIO-I SLIM	53
9. YARDY HP CONNECTIONS	61
10. CONNECTION INT AND KADC	67
10. SYS-TO SYSTEM TOUCH MANAGER & WEB APP	69

1. Tabella riepilogativa Controlli

1.1 Standard controls

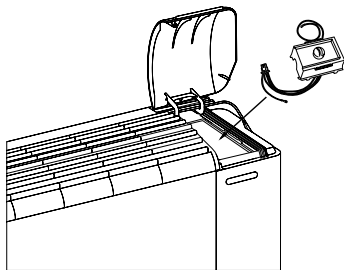
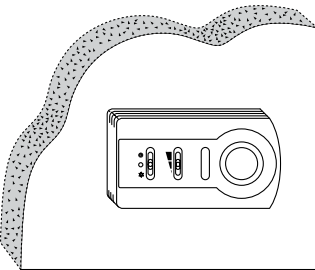
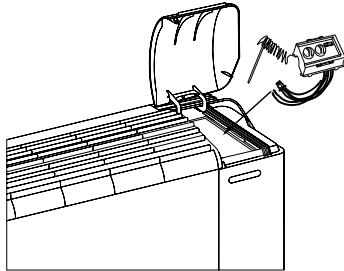
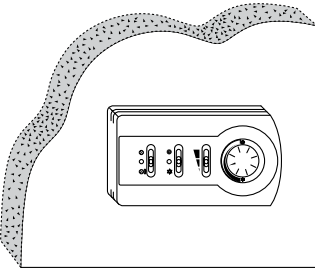
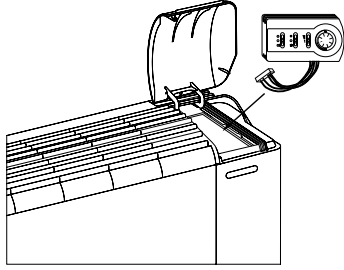
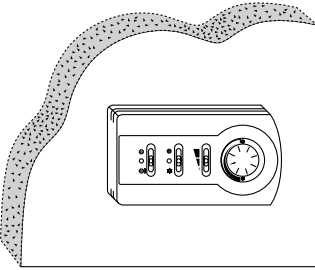
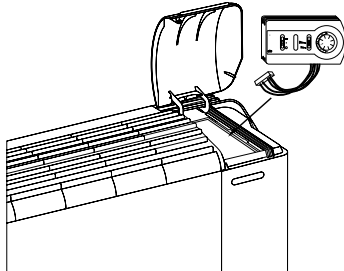
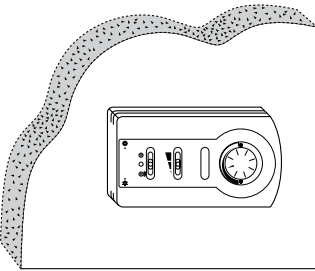
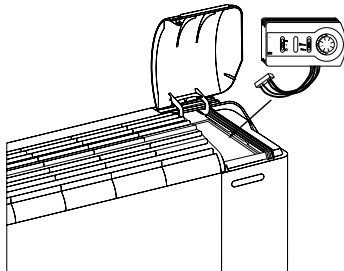
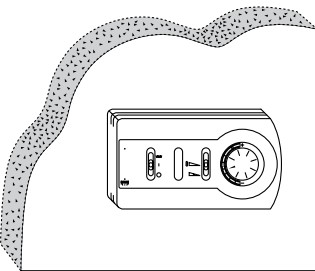
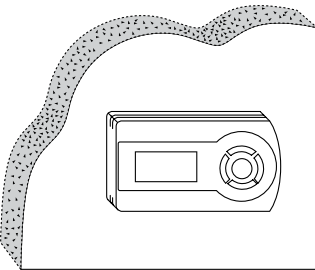
Supplied separately		Factory Fitted	
For installation on board the machine		On-board	
KC		KCV2	
KTA		KTCV2	
KBTCV2		KTCV2	
KBTCVA		KTCVA	
KBTCVR		KTCVR	
-	-	KTVD KTVDM KTVDI KTDVIM	

1.2 Advanced controls LIT-TOUCH

		Supplied separately		Factory Fitted
		For installation on board the machine	For wall mounting	On-board
Panel	 KPLT	KCF/B 	KCF/P+KPLT 	CF/B

* For DIVA and DIVA-I, mounting of the KRLTI / KRLTM receiver (supplied only separately) is provided near the ceiling

.2. Functions standard controls

COMPATIBLE FAN COILS:

YARDY-I EV3 / YARDY EV3 cased	YARDY-I EV3 / YARDY EV3 concealed	YARDY-ID2 / YARDY-DUCT2 ducted	YARDY-HP	DIVA-I / DIVA

2.1 Standard controls

STANDARD FAN COIL (*)	INSTALLATION:	3-speed ON/OFF switch	0-10 Vdc Minimum fan analogue	Room thermostat	Thermostat output	Air sensor with remote control option	Summer/winter switch	3-way ON/OFF valve control	2-way ON/OFF valve control	Electric heater control	Continuous ventilatory thermostat	2-pipe systems	4-pipe systems	Weekly time bands	Control interface for 4 fan coil units	Serial interface
KC C	→ KC - ❖ C on board	◆														
KTA TATM	→ KTA - ❖ TATM on board	◆		◆	◆		◆									
KCV2	→ KCV2 receiver	◆			◆		◆									◆
KTCV2	→ KTCV2 wall mounted → KBTCV2 - ❖ TCV2 on board	◆		◆	◆	ACCESSORY	◆	◆	◆	◆	◆	◆	◆			◆
KTCVA	→ KTCVA wall mounted → KBTCVA - ❖ TCVA on board	◆		◆	◆		◆	◆	◆		◆	◆				◆
KTCVR	→ KTCVR wall mounted → KBTCVR - ❖ TCVR on board	MANUAL/AUTOMATIC SPEED ◆		REGULATION ±5°C ◆	◆		◆	◆	◆	◆			◆	◆		◆
STANDARD FAN COIL	→ KTVD semi-recessed in wall	MANUAL/AUTOMATIC SPEED ◆		◆	TIMED (A) ◆		AUTOMATIC (B) ◆	◆	◆	◆	◆	◆	◆	◆	◆	◆
	→ KTVDM semi-recessed in wall	MANUAL/AUTOMATIC SPEED ◆		◆	TIMED (A) ◆		AUTOMATIC (B) ◆	◆	◆	◆	◆	◆	◆	◆	◆	◆
INVERTER FAN COIL	→ KTVDI semi-recessed in wall	MANUAL/AUTOMATIC SPEED ◆	◆	◆	TIMED (A) ◆		AUTOMATIC (B) ◆	◆	◆	◆	◆	◆	◆	◆		
	→ KTVDIM semi-recessed in wall	MANUAL/AUTOMATIC SPEED ◆	◆	◆	TIMED (A) ◆		AUTOMATIC (B) ◆	◆	◆	◆	◆	◆	◆	◆		◆

(A) Fan or minimum thermostat with KSO probe (accessory) start delay.
 (B) Manual summer/winter switch or by contact or automatic with KSO probe (accessory).
 ❖ Factory mounted → supplied loose

(*) Per utilizzo di controlli standard KCV2, KTCV2, KTCVA, KTCVR su ventilconvettori Inverter è disponibile il convertitore analogico digitale KADC.

2.2 Features standard checks

- **KC** (supplied separately)
- **C** (factory fitted)

OFF/1/2/3 speed switch (for MVP and MVT). On board installation only.

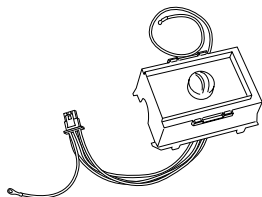

- **KTA** (supplied separately)
- **TA** (factory fitted)
- **TATM** (factory fitted)

Room thermostat complete with OFF/1/2/3 speed and SUMMER/WINTER switch (for MVP and MVT) with the possibility of connecting the minimum thermostat externally. On board installation only. The TATM version is supplied complete with the minimum thermostat.

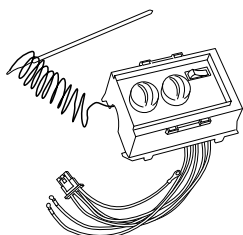

- **KCV2** (supplied separately)

Panel with 3-speed switch complete with the summer/off/winter switch with the possibility of connecting the minimum thermostat externally. Wall mounted.

(dimensions 145 x 82 x 40 mm)

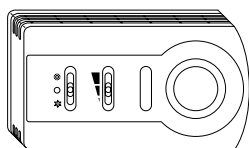

- **KTCV2-KBTCV2** (supplied separately)
- **TCV2-TCV2TM** (factory fitted)

Control and adjustment panel including: off/continuous ventilation/thermostat ventilation switch; room thermostat; summer/winter switch; speed switch; auxiliary contacts (230 Vac) for On/Off valve control in 2-pipe systems, with 2 pipes with electrical resistance (KRER) or 4 pipes, with the possibility of connecting the minimum thermostat externally. Installed on board the machine (KBTCV2) or on the wall (KTCV2).

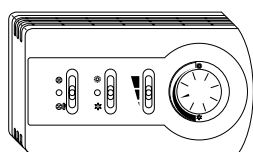

The TCV2TM control is supplied complete with the minimum thermostat.

(dimensions 145 x 82 x 40 mm)

- **KTCVA-KBTCVA** (supplied separately)
- **TCVA** (factory fitted)

Electronic control panel including: continuous ventilation/off/thermostat ventilation switch; 3- speed switch; room thermostat; automatic summer/winter switch; red/green heating/cooling mode signal LED; auxiliary contact (230 Vac) for ON/OFF valve control in 2-pipe systems.

Installed on board the machine (KBTCVA) or on the wall (KTCVA).

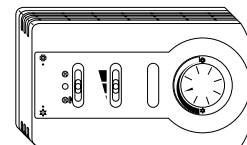

NOTE: the control does not work with a 2-way valve.

The heating-cooling switchover occurs automatically via detection of the water temperature in the fan coil upstream the valve according to the following logic.

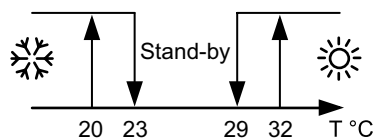

T Water temperature

- **KTCV2-KBTCV2** (supplied separately)
- **TCV2-TCV2TM** (factory fitted)

Electronic control panel including: on/off/electrical resistance switch; automatic summer/winter switchover; automatic speed/minimum speed switch; comfort $\pm 5^{\circ}\text{C}$ adjustment knob; auxiliary contacts (230 Vac) to control the ON/OFF 3-way valve in 2-pipe systems and 2-pipe systems with electrical resistance (KRER); auxiliary contacts (230 Vac) to control the ON/OFF 3 or 2-way valve in 4-pipe systems. Minimum thermostat function, destratification cycle and dirty filter signal (Yardy only).

On-board assembly (KBTCV2) or wall-mounted (KTCV2).

NOTE: the control does not work with a 2-way valve

(dimensions 145 x 82 x 40 mm)

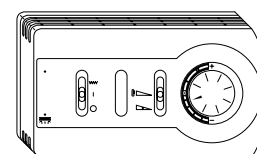

The heating-cooling switchover occurs automatically via detection of the water temperature in the fan coil upstream the valve according to the following logic. If the electric resistance is present, it can be activated.

2-pipe system

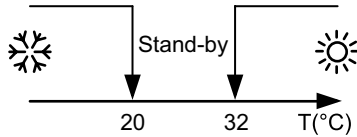

T Water temperature

4-pipe system

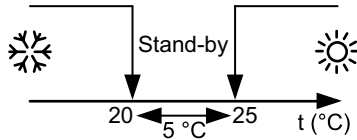

T Water temperature

- **KTVD-KTVDM**(supplied separately)

KTVD

- Electronic control panel with display, semi-recessed wall mounting installation, including an ON/OFF, MODE, 3-speed+AUTO button, SET-POINT or delta SET-POINT change (OFFSET +/-3°C); auxiliary contacts for ON/OFF control valve in 2-pipe systems (2T) with electrical resistance (KRER) and 4-pipe systems (4T); summer/winter manual/automatic/contact switching; fan or minimum thermostat with probe start-up delay (KSO); continuous/thermostatic ventilation; configurable digital inputs (SCR, ECO, SIC and ALARM), weekly time band control; control of up to 4 units with INT interface. Fixing in 503-type three module recessed boxes (not supplied by Rhoss);

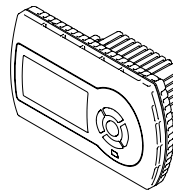

KTVDM

Complete with resident RS485 serial interface (Modbus RTU protocol) (dimensions 128 x 80 x 55.5 mm)

- **KTVDI-KTVDIM** (supplied separately)

KTVDI -

Electronic control panel with display, semi-recessed wall mounting installation, including an ON/OFF, MODE, 3-speed+AUTO button, SET-POINT or delta SET-POINT change (OFFSET +/-3°C); fan control (0-10 Vdc); auxiliary contacts for ON/OFF control valve in 2-pipe systems (2T) with electrical resistance (KRER) and 4-pipe systems (4T); summer/winter manual/automatic/contact switching; fan or minimum thermostat with probe start-up delay (KSO); continuous/thermostatic ventilation; configurable digital inputs (SCR, ECO, SIC and ALARM), weekly time band control; control of up to 4 units (max 50 m shielded cable). Fixing in 503-type three module recessed boxes (not supplied by Rhoss);

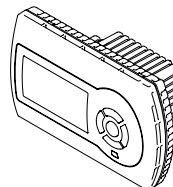

KTVDIM

Complete with resident RS485 serial interface (Modbus RTU protocol)

(dimensions 128 x 80 x 55,5 mm)

- **KSO** (supplied separately)

Remote air temperature probe (2m) for KTCV2, KTCVA, KTCVR, KTVD (M) and minimum thermostat for KTVD (M) and KTVDI(M).

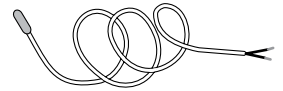

- **KTM** (supplied separately)

Minimum temperature thermostat for winter operation (for KTA - KCV2-KTCV2 - KBTCV2).

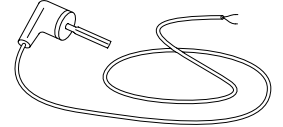

- **INT** (supplied separately)

Interface board to control up to 4 fan coils, to be used in conjunction with KC, KCV2, KTCV2, KTCVA, KTCVR and KTVD (M) type of controls. On board installation.

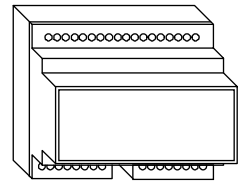

(dimensions 105 x 90 x 70 mm)

- **KADC** (supplied separately)

Analogue digital signal converter to manage Inverter fan coils via commands with a 3-speed relay.

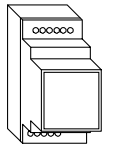

(dimensions 35 x 90 x 65,5 mm)

3. Functions LIT-TOUCH advanced controls

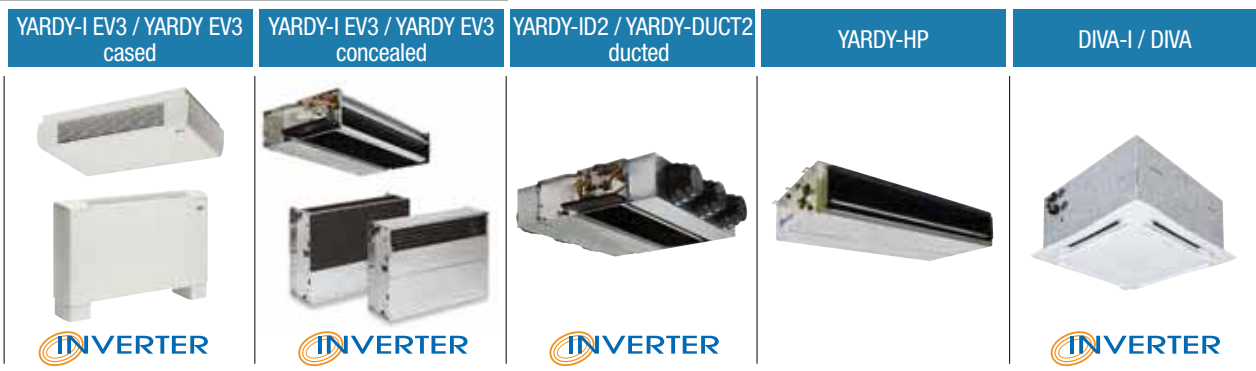

3.1 Advanced controls LIT-TOUCH

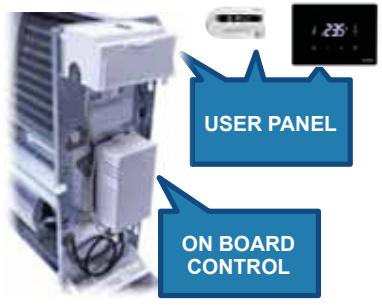

RANGE	YARDY	YARDY DIVA	YARDY DIVA	YARDY DIVA
PANEL	CONTROL	PANEL	REMOTE CONTROL	/
USER	ON BOARD B	WALL-MOUNTED KPLTW or KPLTB	REMOTE KTLT + KRLT ⁽¹⁾	/
TYPE				No user panel
Master/Slave Function	◆ MASTER	◆ MASTER	◆ MASTER	◆ SLAVE

RANGE	ON BOARD CONTROL ADDITIONAL COMPONENTS	Supply		↓	↓	↓	↓	
YARDY	CONTROL	Electronic control for systems: - 2-pipe - 2-pipe with electrical resistance - 4-pipe	Factory fitted		CF/B	CF/P + KPLTB / KPLTW	CF/P + KTLT + KRLT	CF/P
			Supplied separately		KCF/B	KCF/P + KPLTB / KPLTW	KCF/P + KTLT + KRLT	KCF/P
	ADDITIONAL COMPONENTS	Air temperature probe installed on the unit ⁽²⁾	Factory fitted		AS STANDARD	STA1 STA3		
			Supplied separately		AS STANDARD	KSTA1 KSTA3		
		Board with 2 digital outputs that can be configured ⁽³⁾	Factory fitted		DO2			
			Supplied separately		KDO2			
		RS485 Modbus RTU serial board	Factory fitted		SS			/ ⁽⁴⁾
			Supplied separately		KIF485			/ ⁽⁴⁾
DIVA	CONTROL	Electronic control for systems: - 2-pipe - 2-pipe with electrical resistance - 4-pipe	Factory fitted		/	CF/P + KPLTB / KPLTW	CF/P + KTLT + KRLT ⁽¹⁾	CF/P
			Supplied separately		/	KCF/P + KPLTB / KPLTW	KCF/P + KTLT + KRLT ⁽¹⁾	KCF/P
	ADDITIONAL COMPONENTS	Air temperature probe installed on the unit	Factory fitted		/	AS STANDARD		
		Board with 2 digital outputs that can be configured ⁽³⁾	Supplied separately		/	KDO2		
		RS485 Modbus RTU serial board	Supplied separately		/	KIF485	/ ⁽⁴⁾	

Air temperature probe on the wall-mounted control panel, receiver or installed on the unit; water temperature probe always installed.
 (1) Infrared receivers for remote control: KRLT for wall mounting installation; KRLTI for DIVA-type box installation with PLP ceiling panelling, KRLTM for installation on DIVA-type boxes with PLM ceiling panelling.
 (2) (K)STA1 Air temperature probe installed on the unit as an alternative to the temperature probe on the KPLT panel or KRLT receiver, 0.6 m long; probe (K)STA3, 3 m long, is available for the YardyHP range for duct installation.
 (3) 2 digital outputs: ON/OFF, Summer/Winter mode, which can also be configured as a unit alarm.
 (4) For third-party BMS connection with KCF/P control, it is possible to use the RS485 serial board without a user panel.

3.2 Features LIT-TOUCH advanced controls

- **KPLTB** - Glossy black LIT-Touch wired control panel (supplied separately)
- **KPLTW** - Pearl white LIT-Touch wired control panel (supplied separately)

LIT-Touch wired control panel, complete with a LED display to view the room temperature or the desired set-point, with capacitive touch sensors to set the room set-point, the fan speed (AUTO, MIN, MED, MAX) and the summer/winter manual/automatic operating mode and fan (OFF/E/I/Auto/Fan) and ambient air temperature probe.



Wall mounting installation to cover any recessed electrical box 503.

Only combined with control (K)CF/P.

Dimensions 120x86x17 mm



- **KTLT** – LIT-Touch remote control (supplied separately)

IR LIT-Touch remote control to control remotely with KRLT receiver, complete with a wall-mounting support.

Solo in abbinamento a ricevitore KRLT e controllo (K)CF/P.

Dimensions 60 x 160 x 30 mm

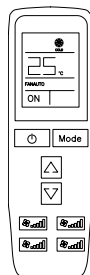

- **KRLT** – LIT-Touch receiver (supplied separately)
IR LIT-Touch receiver to control remotely with the KTLT remote control, complete with an ambient air temperature probe, operating mode LED and emergency micro-key in the case of no remote control.

Installazione a parete.

Only in conjunction with control (K)CF/P.

Dimensions 95 x 58 x 30 mm

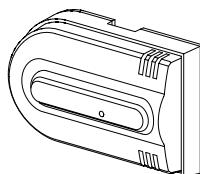

- **KRLTI** – Receiver (supplied separately)

Infrared receiver board for KTLT remote control to be fixed on ABS ceiling panelling.



- **KRLTM** – Receiver (supplied separately)

Infrared receiver board for KTLT remote control to be fixed near the metal panelling.



- **CF/B** - LIT-Touch control with on board control (factory fitted)
- **KCF/B** - LIT-Touch control with on-board control (supplied separately)

On board control complete with a LED display to view the ambient temperature or desired set-point and keys to set the ambient set-point, the speed of the fan (AUTO, MIN, MED, MAX) and the summer/winter manual/automatic operating mode and the fan (OFF/E/I/Auto/Fan).

On board electronic control complete with an air temperature probe, minimum water temperature probe and auxiliary relay contacts to control the ON/OFF valves in 2-pipe systems, and 2-pipe systems with an electrical resistance or in 0-pipe systems.

Continuous 10-3 Vdc speed adjustment for fan coils with an EC-Inverter motor or 3-speed adjustment for fan coils with an AC motor; continuous/thermostated fan setting via parameters.

Set-point adjustment or limited with delta set-point (+/-2°C can be varied) with respect to a reference value, for restricted hotel room operation.

In heating mode in 4-pipe systems. the control for the additional valve can be configured for thermostated activation of a radiator or a radiant panel, with joint or separate operation to the main coil of the fan coil.

Integrated master slave management up to 15 units in total from a single unit with control (K) CF / B.

3 digital inputs, configurable as remote ON/OFF, remote summer/winter, economy, window contact, general alarm in unit input.

The control consists of an electronic board inside a plastic container (IP21), which can contain any additional components:

- **KDO2/DO2** - Additional board with 2 digital relay outputs, which can be configured as ON/OFF call, summer/winter call, unit alarm.
- **KIF485/SS** - RS485 serial board with unit addressing from control panel or remote control.

On board installation - for MVP, MVT versions.

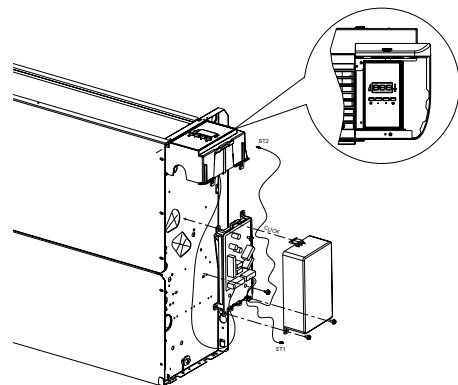

- **CF/P** - LIT-On board touch control (factory fitted)
- **KCF/P** - On board LIT-Touch control (supplied separately)

On board electronic control complete with a minimum water temperature probe and relay auxiliary contacts to control the ON/OFF valves in 2-pipe systems, in 2-pipe systems with an electrical resistance or in 4-pipe systems.

Continuous 10-3 Vdc speed adjustment for fan coils with an EC-Inverter motor or 3-speed adjustment for fan coils with an AC motor; continuous/thermostated fan speed via parameters.

Set-point adjustment or limited with delta set-point (+/-2°C can be varied) with respect to a reference value, for restricted hotel room operation.

In heating mode in 4-pipe systems, the control for the additional valve can be configured for thermostated activation of a radiator or a radiant panel, with joint or separate operation to the main coil of the fan coil.

Integrated master slave control up to .3 slave units, from a single unit with control (KCF/B or KPLT panel or KRLT receiver).

15 digital inputs, configurable as remote ON/OFF, remote summer/winter, economy, window contact, general alarm in unit input.

The control consists of an electronic board inside a plastic container (IP21), which can contain any additional components:

- KDO2/DO2 - Additional board with 2 digital relay outputs, which can be configured as ON/OFF call, summer/winter call, unit alarm.
- KSTA1/STA1 - On board air temperature probe
- KIF485/SS - RS485 serial board with unit addressing from control panel or remote control.

On board installation - for all versions, only combined with a KPLT panel or KRLT receiver.

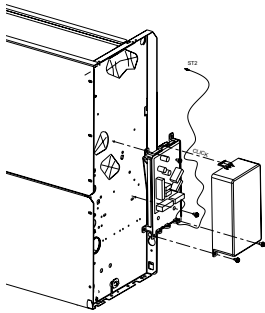

- DO2 - Board with 2 digital outputs
- KDO2 - Board with 2 digital outputs (supplied separately)

Additional board with 2 digital relay outputs, which can be configured as ON/OFF call, summer/winter call, unit alarm

On board installation on control (K)CF/..

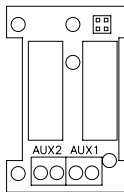

- STA1/STA3 - On board air temperature probe (factory fitted)
- KSTA1/KSTA3 - On board air temperature probe (supplied separately)

On board air temperature probe, in alternate operation with the working probe on the KPLT Panel or on the KRLT Receiver.

On board installation on control (K)CF/P.

The measurement of the STA3 cable is 3 meters



Serial interfaces for LIT-Touch evolved controls

- SS - RS485 serial board to control CF/.. (factory fitted)
- KIF485 - RS485 serial board to control KCF/.. (supplied separately)

RS485 serial interface board for SYS-TO (System Touch Manager) by Rhoss or third-party supervision (Protocols supported: Modbus® RTU).

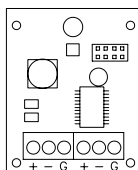

Gateway

• KGTW-BAC

RS485/BACnet gateway for communication from MODBUS RTU to BACNET IP; up to 32 fan coils can be connected. The fan coils must be equipped with an SS serial interface (KIF485).

• KGTW-LON

RS485/FTT10-LonWorks gateway for communication from MODBUS RTU to FTT10-LonWorks; up to 32 fan coils can be connected. The fan coils must be equipped with an SS serial interface (KIF485).

3.3 Dimensions

Control panel (KPLT)

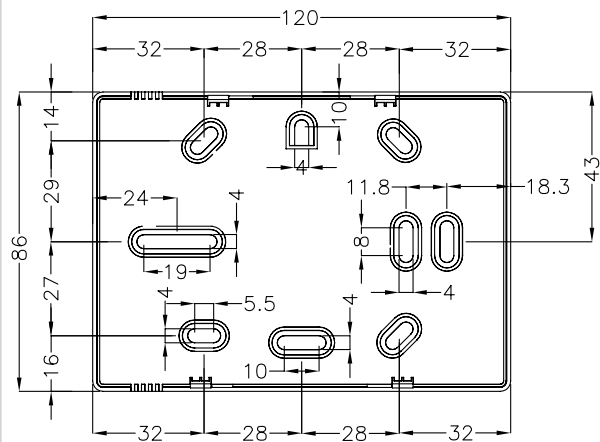
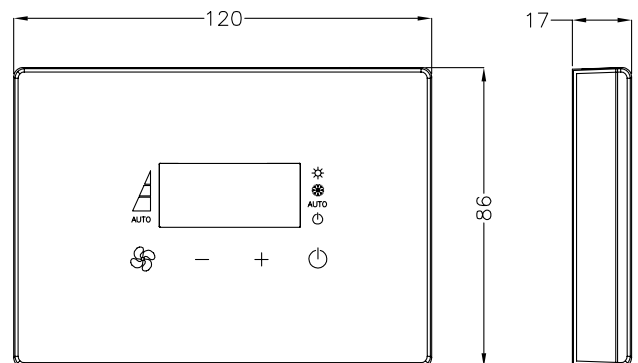

Infrared remote control (KTLT)

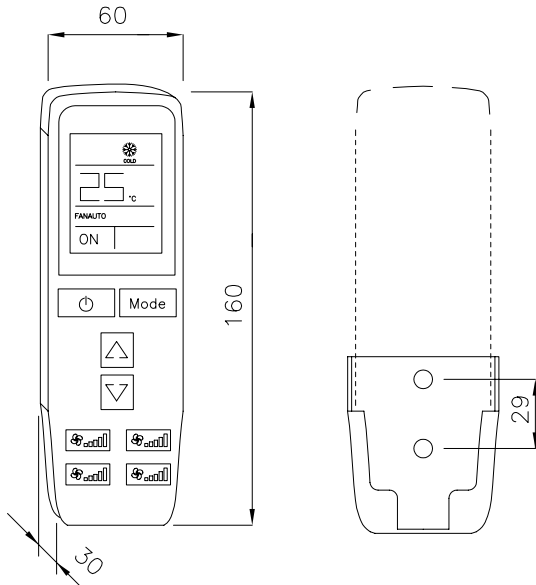

Wall receiver (KRLT)

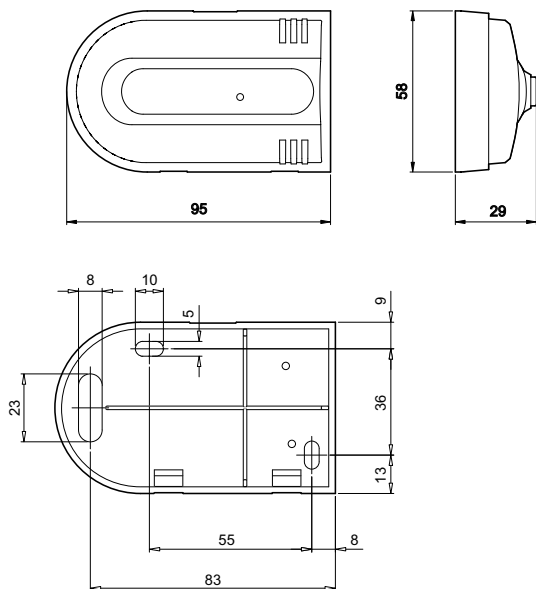

Room regulation

• **Auto**

In AUTO, the terminal unit detects the room temperature and decides which mode to activate (heating or cooling) based on the setpoint set by the user.

AUTO

• **Cool**

Cool is the "cooling" function. In this way the desired regulation can be set by selecting the working set-point. The fan operating mode can be manual or automatic (AUTO).



• **Fan**

Fan is the "ventilation" function. In this operating mode the fan speed can be set as desired (MIN, MED, MAX or AUTO).

FAn

• **Heat**

Heat is the "heating" function. In this operating mode, the desired setting can be set by selecting the working set-point. The fan operating mode can be manual or automatic (AUTO).



• **Heat + Cable**

The HEAT + ELECTRIC RESISTANCE function provides for the HEAT operating mode with automatic activation of the electrical resistance (if declared) based on the detected hot water temperature; it can therefore integrate or replace the hot water battery.

• **Hot Start**

For the HEAT operating mode, it provides for the blocking of the ventilation with the hot water temperature at the battery inlet below certain preset values thus avoiding unpleasant flows of cold air in the environment.

• **Too Cool**

For the COOL operating modes it provides for the blocking of the ventilation with the cold water temperature at the inlet of the battery above a certain pre-set value thus avoiding unpleasant flows of hot air into the environment. Only on 2T systems.

• **Memory**

If the power supply is restored after a power failure, the appliance will resume operation in the mode in which it will immediately be disconnected. MEMORY is also activated in the remote control and alarm ON / OFF functions.

Advanced functions

• **Economy**

Economy is the "energy saving" function. In this operating mode the noise level of the unit is reduced to a minimum and the working set-point values are optimized in order to achieve energy savings; it can, for example, be activated when the room is not occupied. This function can be enabled by parameter and activated via a clean contact.

- **Lock function (*)**

It allows a constrained management of the device in case of applications managed centrally (constrained conditioning).

In fact, it provides only the AUTO mode (or possibly EIR if enabled).

The other possible functions:

- turn the unit off,
- change the Set-point by $\pm 3^{\circ}\text{C}$ (only if the Comfort Control function is enabled),
- change the fan speed (min-med-max-AUTO);

If the EIR function is active, the operating mode depends on the status of the digital input.

On the control panel the display is std.

This function is enabled by parameter.

- **Control panel key lock on the machine and KPLT**

By pressing a combination of keys, it is possible to lock the functions associated with the keys on the control panel.

- **ON/OFF remote control (SCR)**

It provides for switching the appliance on and off remotely by means of a switch (clean contact) for using the unit with centralized management or timed control with an external clock. When the unit is OFF from a remote location, the control panel displays OFF flashing.

- **Summer/Winter remote control (EIR) (*)**

Set the unit to operate in COOL or HEAT at a distance using a switch (dry contact). This function can be enabled by parameter.

- **Security control (SIC) (*)**

It is possible to make the operation of the unit dependent on a remote consent (clean contact). For example, it is possible to interrupt the operation of the unit when a window is opened by means of a contact placed on it.

This function can be enabled by parameter.

- **Comfort Control (*)**

This function blocks the modification of the set-point and allows the setting of a value of $\pm 3^{\circ}\text{C}$ with respect to the set-point set (in HEAT, COOL and AUTO modes).

Example: in a centralized system (Hotel) it is possible to set via serial the set-point of an environment (room) giving the customer the possibility to modify it by only $\pm 3^{\circ}\text{C}$.

This function can be enabled by parameter.

- **Alarm**

In the presence of an alarm that prevents the machine from operating correctly, the display will show the alarm code allowing easy identification of the fault.

(*) Attention: for the setting and modification of the parameters in the electronic board it is always necessary to have a flush panel.

- **Master/Slave connection**

It is a particular function for which a control panel or receiver connected to a fancoil Master, sends some information on the operation in progress to other Slave devices (maximum 14) without control panel, through an electrical connection to be carried out during installation (see diagrams electrical).

In the case of MASTER / SLAVE management, it is possible to use the air temperature probe on the master unit or the temperature probe of each slave unit (if provided).

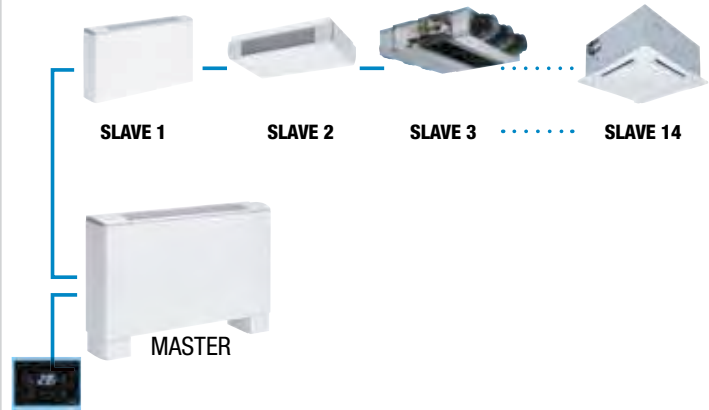

NOTE

With reference to the above example: the distance of the local network (distance between the control panel and the last slave) must not exceed 100 m.

4. Functions standard controls and SLIM-TOUCH controls



4.1 SLIM-TOUCH Advanced controls



RANGE	BRIO-I SLIM			
PANEL	CONTROL	CONTROL	PANEL	/
USER	ON BOARD B	ON BOARD B	WALL-MOUNTED KPST	/
TYPE				No user panel
Speed	4 speeds	continuous modulation	continuous modulation	continuous modulation
Master/Slave Function	/	/	◆ MASTER	◆ SLAVE

RANGE	ON BOARD CONTROL	ADDITIONAL COMPONENTS	Supply					
BRIO-I SLIM	ADVANCED CONTROL	Electronic control for 2-pipe systems	Factory fitted		CS.F/B	CS.M/B	CS.M/P + KPST	CS.M/P
			Supplied separately		KCS.F/B	KCS.M/B	KCS.M/P + KPST	KCS.M/P
		Electronic control for 4-pipe systems	Factory fitted		/	CS.M/B	CS.M/P + KPST	CS.M/P
			Supplied separately		/	KCS.M/B	KCS.M/P + KPST	KCS.M/P
	ADDITIONAL COMPONENTS	Air temperature probe installed on the unit	Factory fitted		AS STANDARD		/	
			Supplied separately		AS STANDARD		/	
		RS485 Modbus RTU serial board	Factory fitted		/	SS	AS STANDARD	/ (1)
			Supplied separately		/	KI485	AS STANDARD	/ (1)

Air temperature probe on the wall-mounted control panel or installed on the unit; water temperature probe always installed.
 Controls installed on the right side of the unit; the KDX accessory is required for installations on the top left side.
 (1) For third-party BMS connection with KCS.M/P control, it is possible to use the RS485 serial board without a user panel.

For the unit to operate, it is compulsory to use a combined control that is standard or advanced.

4.2 Standard controls

RANGE	STANDARD CONTROLS	Supply		
BRIO-I SLIM	Board installed on board for 3-speed thermostats, for 2-pipe and 4-pipe systems	Supplied separately		KBS.3
	Board installed on board for thermostats with 0-10V analogue output for 2-pipe systems	Supplied separately		KBS.0



4.3 SLIM-TOUCH advanced controls features

Controls

The Brio-I SLIM range includes a number of commands and controls supplied separately by the units or pre-assembled at the factory

Standard controls

On board controls

- **KBS.3 (supplied separately)**

Electronic board to be combined with 3-speed thermostats for on-board installation, with a minimum temperature probe; 2-4 pipe systems

- **KBS.0 (supplied separately)**

Electronic board to be combined with thermostats with a 0-10V analogue output for on-board installation, with a minimum temperature probe; 2-pipe systems only

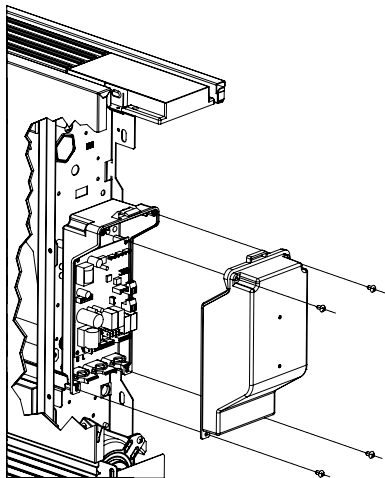

Advanced controls

On board controls

- **KCS.M/B (supplied separately)**
- **CS.M/B (factory fitted)**

On-board touch control and continuous speed modulation electronic control to adjust the room temperature, ON/OFF, summer/winter, Auto, Night, MIN and MAX speed, ON/OFF valve control, minimum water temperature probe and air probe, presence input, optional interface (KI485/SS); only for MVP, MVR version

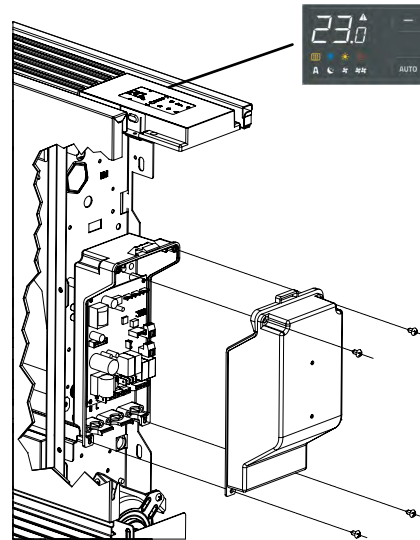

Wall controls

- **KTCV2 (supplied separately)**

Control and regulation panel consisting of: OFF/thermostated ventilation /continuous ventilation (cannot be activated) switch; room thermostat; summer/winter switch; speed switch; auxiliary contacts to control the ON/OFF valves in 2 or 4-pipe systems; only combined with the KBS.3 board

- **KTCVA (supplied separately)**

Electronic control panel including: thermostated ventilation / OFF/continuous ventilation (cannot be activated) switch; 3-speed switch, room thermostat; automatic summer/winter switch; red/green heating/cooling operating LED, auxiliary contact for ON/OFF 3-way valve control for 2-pipe systems; only in combination with board KBS.3

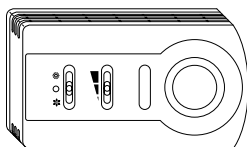

(dimensions 145 x 82 x 40 mm)

- **KCS.F/B (supplied separately)**
- **CS.F/B (factory fitted)**

On-board touch control and 4-speed electronic control to adjust the room temperature, ON/OFF, summer/winter, Night, MIN, MED and MAX speed, ON/OFF valve control, minimum water temperature probe and air probe; only for 2-pipe systems and MVP, MVR version

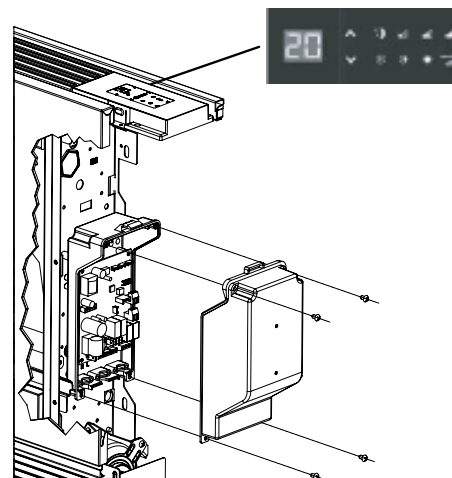

- **KCS.M/P (supplied separately)**
- **CS.M/P (factory fitted)**

Continuous speed modulation electronic control for ON/OFF valve control, minimum water temperature probe, presence input, only combined with a KPST panel (up to a maximum of 31 (K)CS.M/P boards that can be connected in a Master/Slave configuration with the KPST panel)

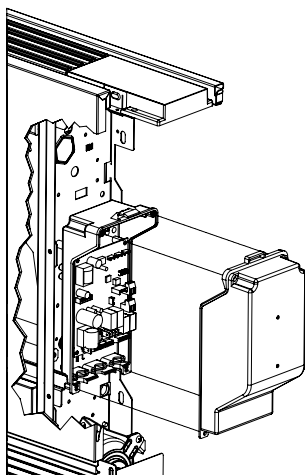

Flush panel

- **KPST (supplied separately)**

Wall-mounted slim touch control panel with probe to control the room temperature, ON/OFF, summer/winter, Auto, Night, MIN and MAX speed, with integrated RS485 Modbus RTU interface, to be combined with (K)CS.M/P control



Serial interface.

- **KI485 (supplied separately)**
- **SS (factory fitted)**

RS485 Modbus RTU serial interface, only in combination with (K)CS.M/B control

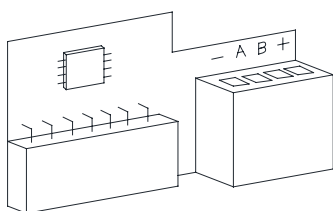

5. Specifications of checks

5.1 Specifications of standard checks

	KC C	TA KTA TATM	KCV2	KTCV2 TCV2 TCV2TM	KTCVA KBTCVA TCVA	KTCVR KBTCVR TCVR	KTVD KTVDIM	KTVDI KTVDIM	
Power supply	230 Vca ±10% - 50/60 Hz						230Vac ±10% - 50/60Hz		
Protection class	/		IP30				IP30		
EC regulations	EN60730-1		EN50081-1 / EN50082-1 / EN60730-1				EN60730-1 / EN61000-6-3 / EN61000-6-1		
Adjustment range	/		+5°C++30°C			+15°C + +25°C Heating +20°C + +30°C Cooling	+16°C++32°C		
Output	/		/	n° 1 relè SPDT 230Vca 6A	n° 1 relè SPDT 230Vca 6A	n° 5 triac 230Vca	n°5 relè SPST 230Vac 3A AC1	n°3 relè SPST 230Vac 3A AC1	
Total maximum load	16(3) A	15(2,5) A thermostat	6A AC1	6A AC1	6A AC1	1,2 A (35°C) engine outputs 0,5 A valve output or relay for resistance	4A AC1		
Operating range	0°C++50°C 10..90% RH								
Colour	/		/		RAL 9010			RAL 9010	

5.2 Specifications of LIT-TOUCH evolved controls

	Panel on board	Wall panel (KPLT)	Remote control (KTLT)	KCF CF	KDO2 DO2	KSTA1 STA1 KSTA3 STA3
Power supply	(from CF card)	(from CF card)	n° 2 xine batteries AAA 1,5V	230Vac ±10% 50/60Hz	(from CF card)	
Protection class	IP30	IP30	IP30	IP21 if inside the plastic container	IP21 if inside the plastic container	
EC regulations	EN60730-1 / EN60730-2-9		EN60730-1 / EN60730-2-9			
Adjustment range	15±30°C	15±30°C	8±30°C			
Output					n°5 relè 230Vac 2A AC1	n°2 relè 230Vac 8A AC1
Total maximum load						
Operating range	-5°C+55°C 10..90% RH	-5°C+55°C 40..80% RH	10°C+35°C 45..75% RH	-5°C+55°C 10..90% RH	-5°C+55°C 10..90% RH	-50±105°C
Colour	RAL 7035	Black or White	RAL 9003	RAL 7035	Black	

5.3 Specifications of SLIM-TOUCH evolved controls

	Panel on board	Wall panel (KPST)	KCS CS
Power supply	(from CS card)	(from CS card)	230Vac ±10% 50/60Hz
Protection class	IPX0	IPX0	IPX0
EC regulations			
Adjustment range	16±28°C	16±28°C	16±28°C
Output			n°4 relè 230Vac 2A AC1
Total maximum load			
Operating range	-10°C+50°C 15..80% RH	-10°C+50°C 15..80% RH	-10°C+50°C 15..80% RH
Colour	Black	Black	Black

6. Electrical connection of the units

6.1 Standard controls

Connection YardyEV

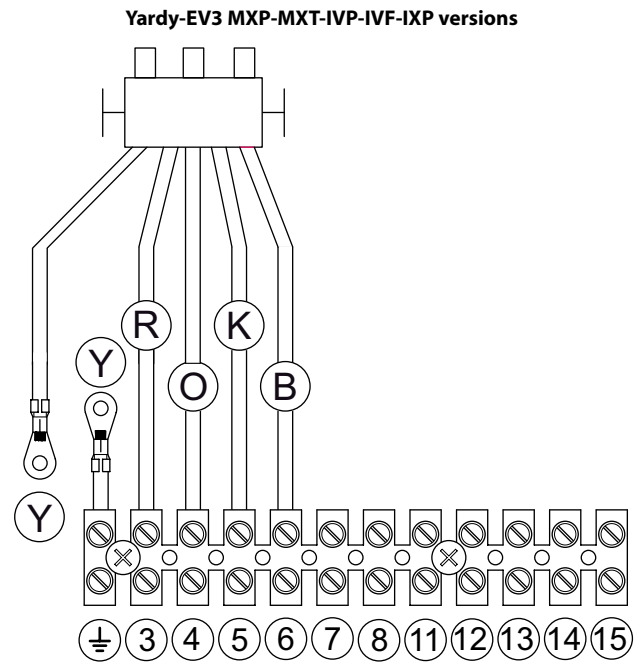
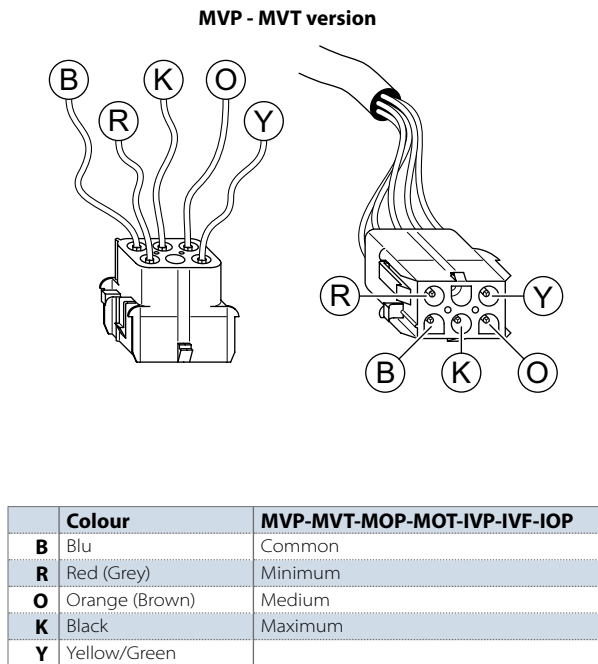

NOTE

When mounting command KC or KTA drives MXP / MXT installed vertically, this wiring and its label must be removed.

DUCT2 versions

YardyDUCT2 version CXP

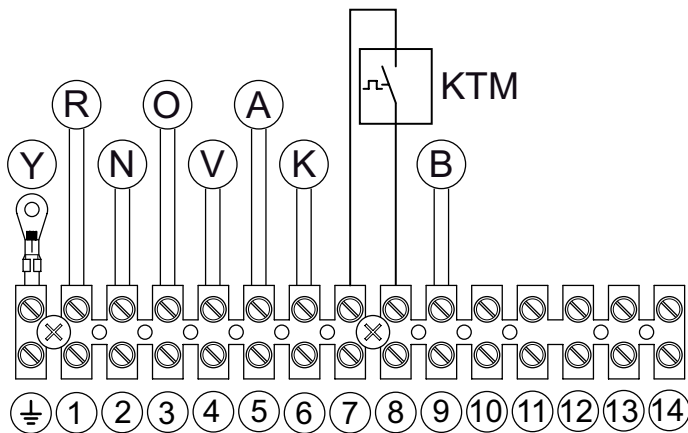

	Colour	DUCT2
B	Blu	Common
K	Black	Speed VI (max)
A	Grey	Speed V
V	Violet	Speed IV
O	Orange	Speed III
B	Brown	Speed II
R	Red	Speed I (min)
Y	Yellow/Green	
KTM	Minimum temperature thermostat (accessory)	

Yardy-I EV3 - Yardy-ID2

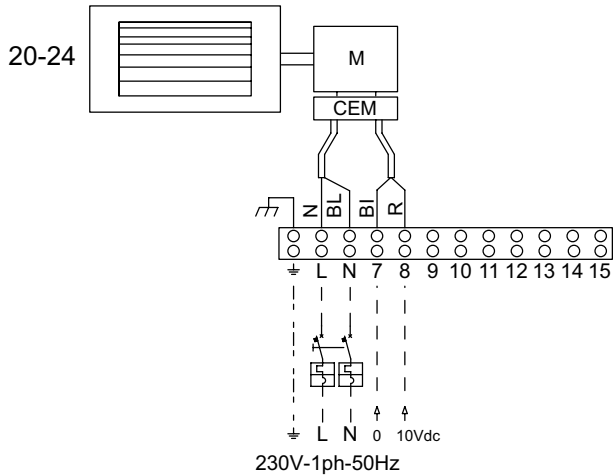

- Data for connecting an external controller to the fan coil. Motor input impedance 67 KOhm. Signal 0-10 Vdc.
- Start-up limit 1V.
- Shutdown limit 0.9V.
- Maximum speed 10 Vdc.

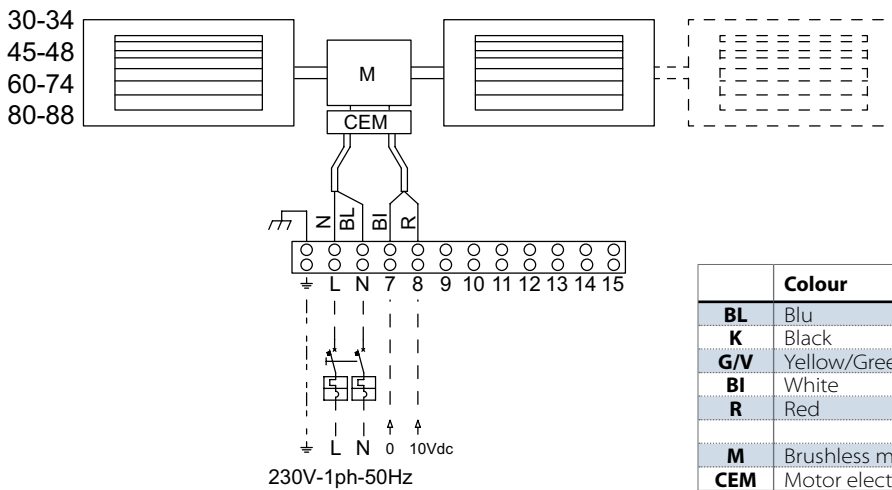

	Colour	
BL	Blu	Neutral
K	Black	Line
G/V	Yellow/Green	Earth
BI	White	0Vdc
R	Red	10Vdc
M	Brushless motor	
CEM	Motor electronic control	

NOTE

When designing and sizing the power line and protection systems for units with a brushless EC Inverter-type and Yardy-I, Yardy-ID type of synchronous motor, pay attention to the leakage current values to earth as they are higher than traditional units with an asynchronous motor.

It is always advisable to install the units with specific residual current protection.

The Yardy-I, Yardy-ID units with a brushless EC Inverter-type of synchronous motor, conform to the limits stipulated in standard IEC-EN 60335 with a maximum dispersion of 3.5 mA, which is permissible and imposed by the standard.

Electrical connection standard controls YardyEV

- **KC** (supplied separately)
- **C** (factory fitted)

OFF/1/2/3 speed switch (for MVP and MVT). On board installation only.

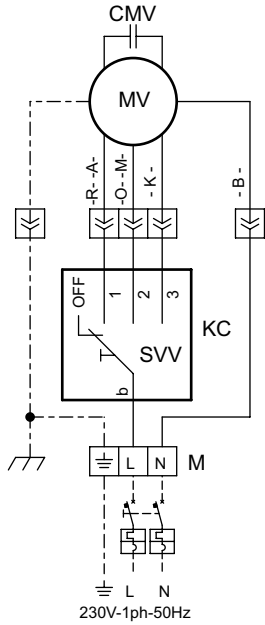
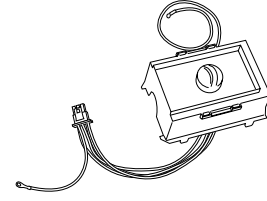

KC	Control panel
CMV	Fan motor condenser
M	Terminal board
MV	Fan motor
SVV	Fan speed selector
----	Connection by installer

COM	MIN	MED	MAX
- B -	- R -	- O -	- K -
Blu	Red	Orange	Black
	- A -	- M -	
	Grey	Brown	

- **KTA** (supplied separately)
- **TA** (factory fitted)
- **TATM** (factory fitted)

Room thermostat complete with OFF/1/2/3 speed and SUMMER/WINTER switch (for MVP and MVT) with the possibility of connecting the minimum thermostat externally. On board installation only. The TATM version is supplied complete with the minimum thermostat.

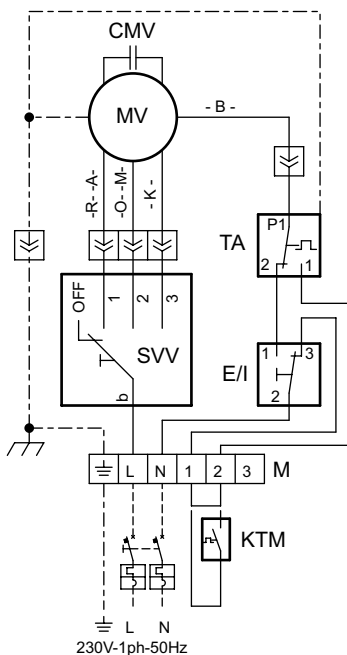
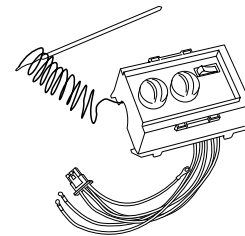

KTA	Control panel
CMV	Fan motor condenser
M	Terminal board
MV	Fan motor
SVV	Fan speed selector
KTM	Minimum thermostat (accessory)
Ta	Room thermostat
E/I	Summer/Winter switch
----	Connection by installer

COM	MIN	MED	MAX
- B -	- R -	- O -	- K -
Blu	Red	Orange	Black
	- A -	- M -	
	Grey	Brown	

- **KCV2** (supplied separately)

Panel with 3-speed switch complete with the summer/off/winter switch with the possibility of connecting the minimum thermostat externally. Wall mounted.

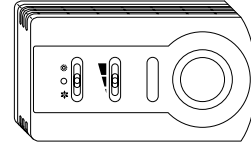

(dimensions 145 x 82 x 40 mm)

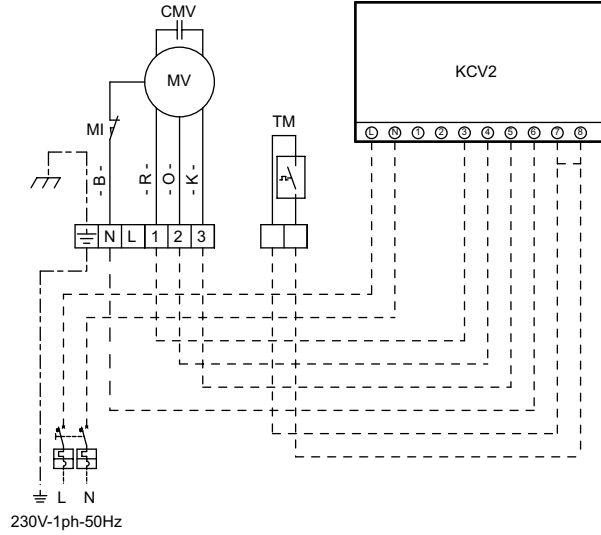

KCV2	Control panel
CMV	Fan motor condenser
M	Terminal board
MV	Fan motor
SVV	Fan speed selector
KTM	Minimum thermostat (accessory)
---	Connection by installer

COM	MIN	MED	MAX
- B -	- R -	- O -	- K -
Blu	Red	Orange	Black
	- A -	- M -	
	Grey	Brown	

- **KTCV2-KBTCV2** (supplied separately)
- **TCV2-TCV2TM** (factory fitted)

Control and adjustment panel including: off/continuous ventilation/thermostat ventilation switch; room thermostat; summer/winter switch; speed switch; auxiliary contacts (230 Vac) for On/Off valve control in 2-pipe systems, with 2 pipes with electrical resistance (KRER) or 4 pipes, with the possibility of connecting the minimum thermostat externally. Installed on board the machine (KBTCV2) or on the wall (KTCV2).

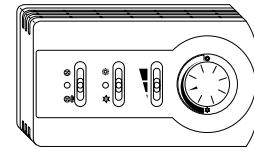

(dimensions 145 x 82 x 40 mm)

The TCV2TM control is supplied complete with the minimum thermostat.

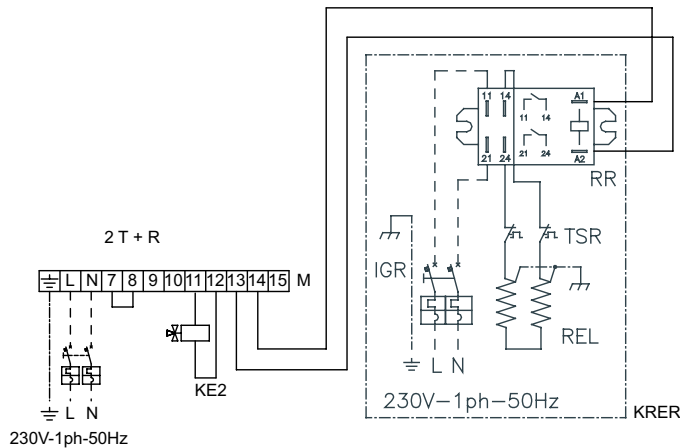
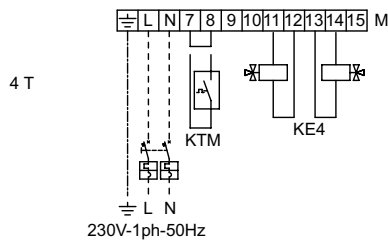
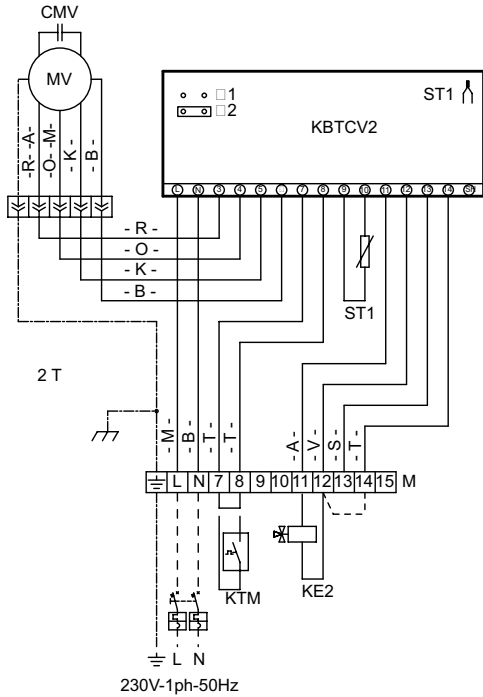

KBTCV2	Control panel
CMV	Fan motor condenser
M	Terminal board
MV	Fan motor
ST1	Air temperature probe
KTM	Minimum thermostat (accessory)
KE2	Hot/cold valve (accessory)
KE4	Hot/cold valve (accessory)
KRER	Electric heater + relais (accessory)
---	Connection by installer

COM	MIN	MED	MAX
- B -	- R -	- O -	- K -
Blu	Red	Orange	Black
	- A -	- M -	
	Grey	Brown	

- T -	White
- S -	Pink
- V -	Violet
- A -	Grey
- M -	Brown
- O -	Orange
- B -	Blu
- R -	Red
- K -	Black

NOTE

Jumper J1 closed = Internal Air Probe ST1
 Jumper J2 Closed = Air probe ST1 External
 In the presence of the electrical resistance, do not mount the TM.

2T = 2 pipes
 4T = 4 pipes
 2T + R = 2 pipes + cable

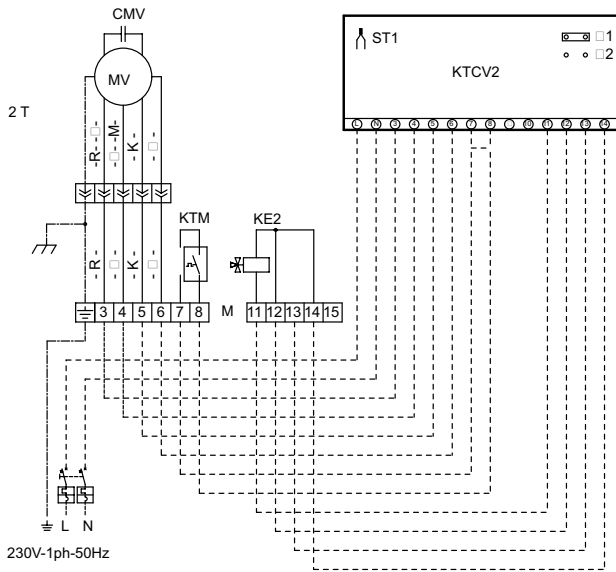

KTCV2	Control panel
CMV	Fan motor condenser
M	Terminal board
MV	Fan motor
ST1	Air temperature probe
KTM	Minimum thermostat (accessory)
KE2	Hot/cold valve (accessory)
KE4	Hot/cold valve (accessory)
KRER	Electric heater + relais (accessory)
----	Connection by installer

COM	MIN	MED	MAX
- B -	- R -	- O -	- K -
Blu	Red	Orange	Black
	- A -	- M -	
	Grey	Brown	

- T -	White
- S -	Pink
- V -	Violet
- A -	Grey
- M -	Brown
- O -	Orange
- B -	Blu
- R -	Red
- K -	Black

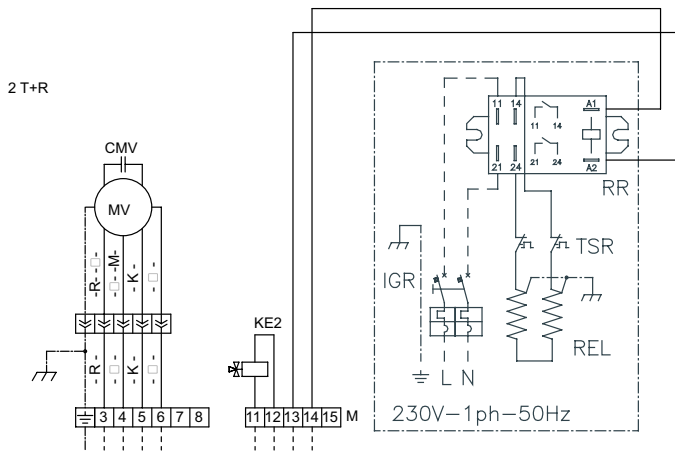

NOTE

Jumper J1 closed = Internal Air Probe ST1

Jumper J2 Closed = Air probe ST1 External

In the presence of the electrical resistance, do not mount the TM.

2T = 2 pipes

4T = 4 pipes

2T + R = 2 pipes + cable

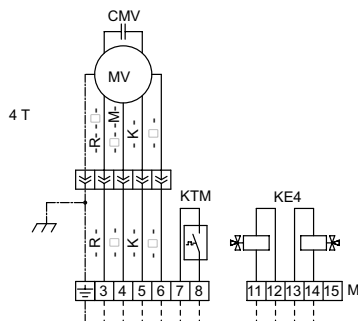

- **KTCVA-KBTCVA** (supplied separately)
- **TCVA** (factory fitted)

Electronic control panel including: continuous ventilation/off/thermostat ventilation switch; 3- speed switch; room thermostat; automatic summer/winter switch; red/green heating/cooling mode signal LED; auxiliary contact (230 Vac) for ON/OFF valve control in 2-pipe systems.

Installed on board the machine (KBTCVA) or on the wall (KTCVA).

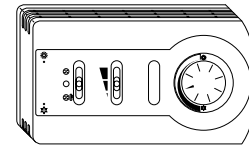

(dimensions 145 x 82 x 40 mm)

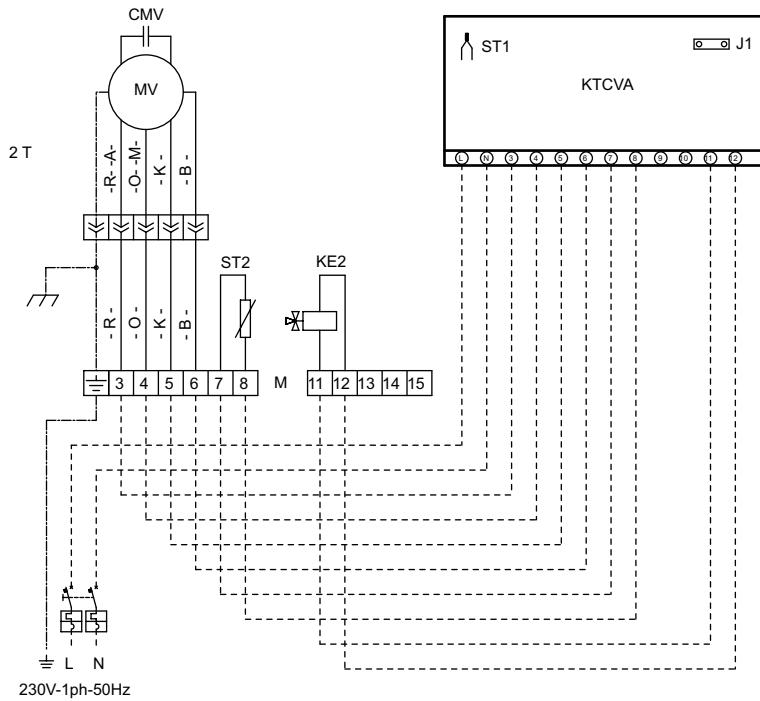

KTCVA	Control panel mounted on the wall
KBTCVA	Control panel mounted on the machine
CMV	Fan motor condenser
M	Terminal board
MV	Fan motor
ST1	Air temperature probe
ST2	Water temperature probe
KE2	Hot/cold valve (accessory)
---	Connection by installer

COM	MIN	MED	MAX
- B -	- R -	- O -	- K -
Blu	Red	Orange	Black
	- A -	- M -	
	Grey	Brown	

2T = 2 pipes

- T -	White
- S -	Pink
- V -	Violet
- A -	Grey
- M -	Brown
- O -	Orange
- B -	Blu
- R -	Red
- K -	Black

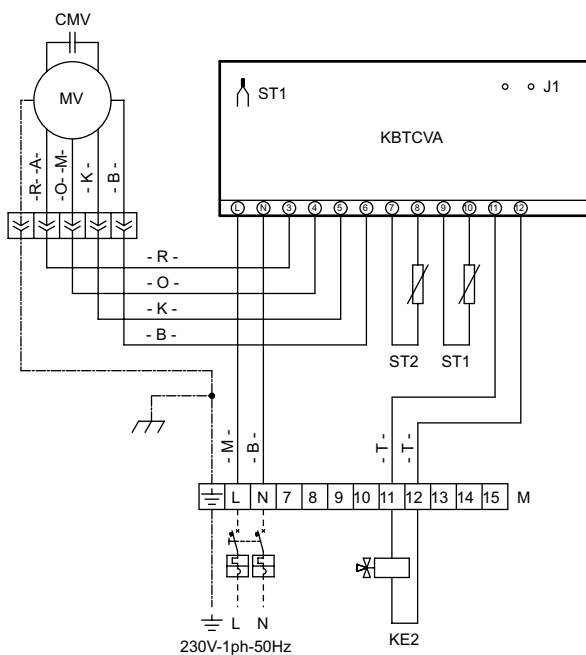

NOTE

Jumper 1 closed = Internal Air Probe ST1

Jumper J1 open = External Air Probe ST1

The ST2 water probe is included in the thermostat packaging.

If the 3-way ON / OFF valve is present, the water probe ST2 must be placed upstream of the valve itself.

NOTE: the control does not work with a 2-way valve.

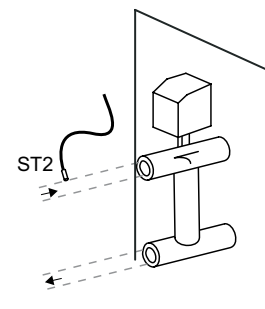

- **KTCVR-KBTCVR** (supplied separately)
- **TCVR** (factory fitted)

Electronic control panel including: on/off/electrical resistance switch; automatic summer/winter switch; automatic/minimum speed switch; $\pm 5^{\circ}\text{C}$ comfort adjustment knob; auxiliary contacts (230 Vac) for ON/OFF valve control in 2-pipe systems, with 2 pipes with electrical resistance or 4 pipes. Minimum thermostat function, destratification cycle and dirty filter signal.

Installed on board the machine (KBTCVR) or on the wall (KTCVR).

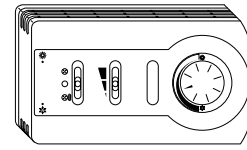

(dimensions 145 x 82 x 40 mm)

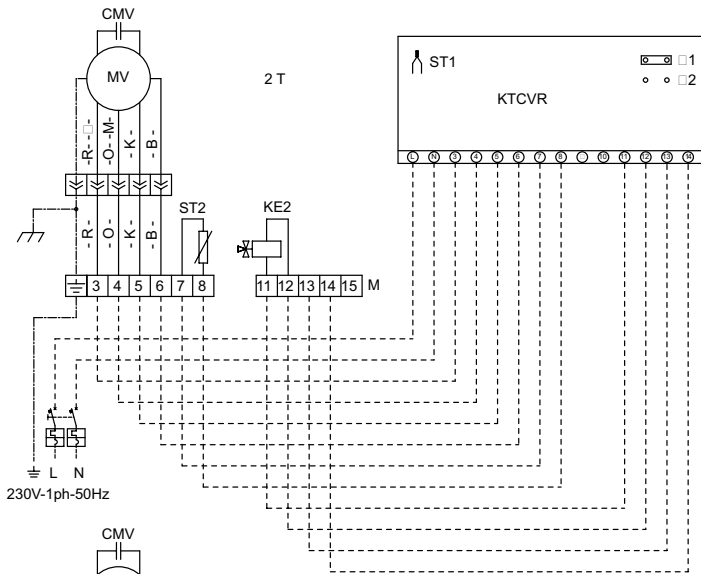

KTCVR	Control panel mounted on the wall
CMV	Fan motor condenser
M	Terminal board
MV	Fan motor
ST1	Air temperature probe
ST2	Water temperature probe
KE2	Hot/cold valve (accessory)
KE4	Hot/cold valve (accessory)
KRER	Electric heater + relais (accessory)
---	Connection by installer

COM	MIN	MED	MAX
- B -	- R -	- O -	- K -
Blu	Red	Orange	Black
	- A -	- M -	
	Grey	Brown	

- T -	White
- S -	Pink
- V -	Violet
- A -	Grey
- M -	Brown
- O -	Orange
- B -	Blu
- R -	Red
- K -	Black

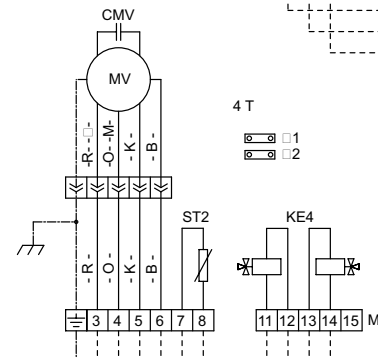

NOTE

Jumper J1 closed = Internal Air Probe ST1

Jumper J1 open = External Air Probe ST1

Jumper J2 closed = 4-pipe system

Open Jumper J2 = 2-pipe system (2 pipes + resistor)

The ST2 water probe is included in the thermostat packaging.

2-pipe system (2 pipes + resistor) Jumper J2 open and water probe ST2 upstream of the valve (if present)

4-pipe system, Jumper J2 closed and water probe ST2 positioned on the hot battery (with or without valve)

NOTE: the control does not work with a 2-way valve.

2T = 2 pipes

4T = 4 pipes

2T + R = 2 pipes + cable

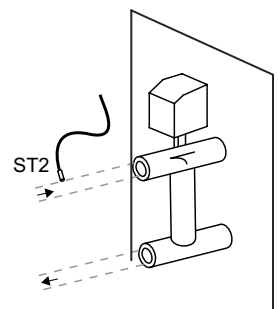
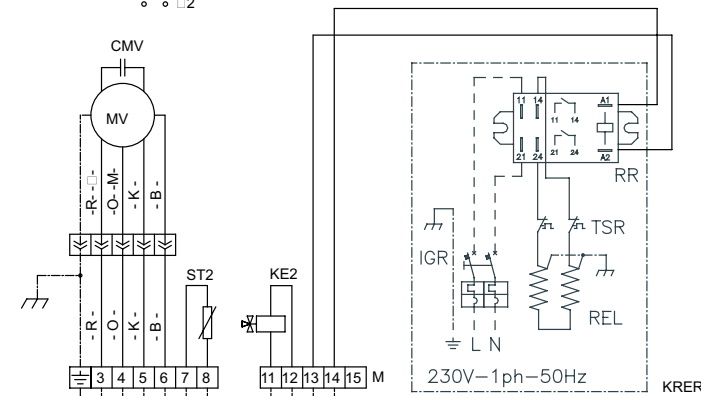

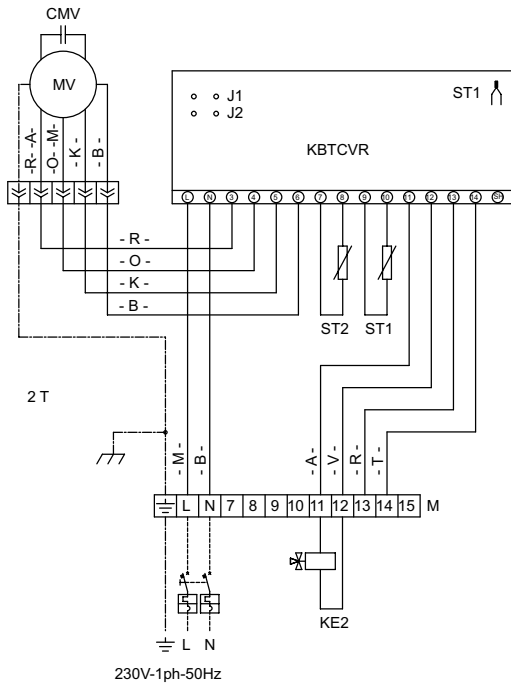

KBTCVR	Control panel mounted on the machine
CMV	Fan motor condenser
M	Terminal board
MV	Fan motor
ST1	Air temperature probe
ST2	Water temperature probe
KE2	Hot/cold valve (accessory)
KE4	Hot/cold valve (accessory)
KRER	Electric heater + relays (accessory)
- - -	Connection by installer

COM	MIN	MED	MAX
- B -	- R -	- O -	- K -
Blu	Red	Orange	Black
	- A -	- M -	
	Grey	Brown	

- T -	White
- S -	Pink
- V -	Violet
- A -	Grey
- M -	Brown
- O -	Orange
- B -	Blu
- R -	Red
- K -	Black

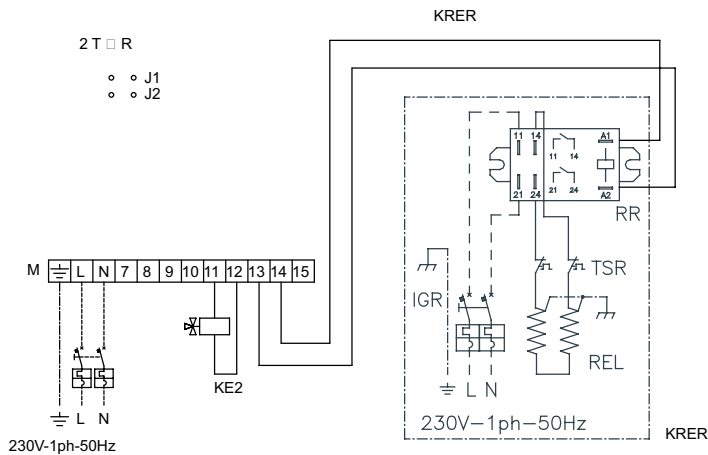

NOTE

Jumper J1 closed = Internal Air Probe ST1
 Jumper J1 open = External Air Probe ST1
 Jumper J2 closed = 4-pipe system
 Open Jumper J2 = 2-pipe system (2 pipes + resistor)
 2-pipe system (2 pipes + resistor) Jumper J2 open and water probe ST2 upstream of the valve (if present)
 4-pipe system, Jumper J2 closed and water probe ST2 positioned on the hot battery (with or without valve)
NOTE: the control does not work with a 2-way valve.

2T = 2 pipes
 4T = 4 pipes
 2T + R = 2 pipes + cable

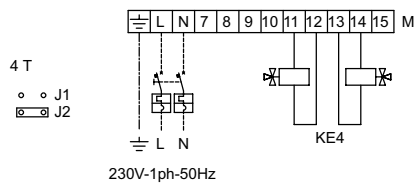

- **KTM** (supplied separately)

Minimum temperature thermostat for winter operation (for KTA - KCV2 - KTCV2 - KBTCV2).

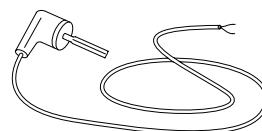

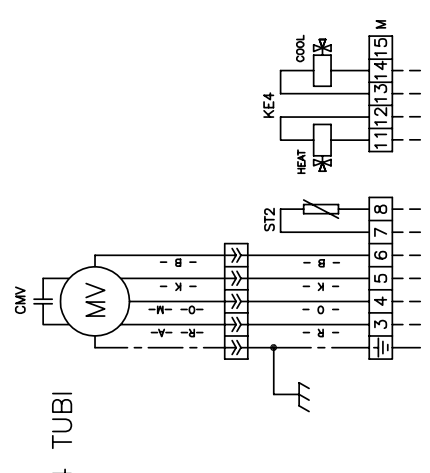
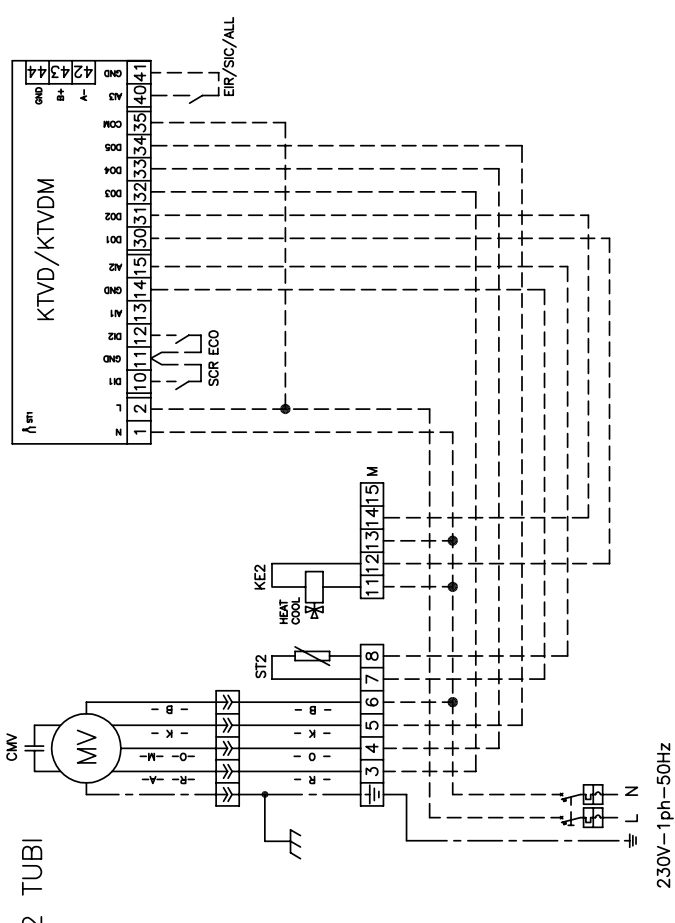
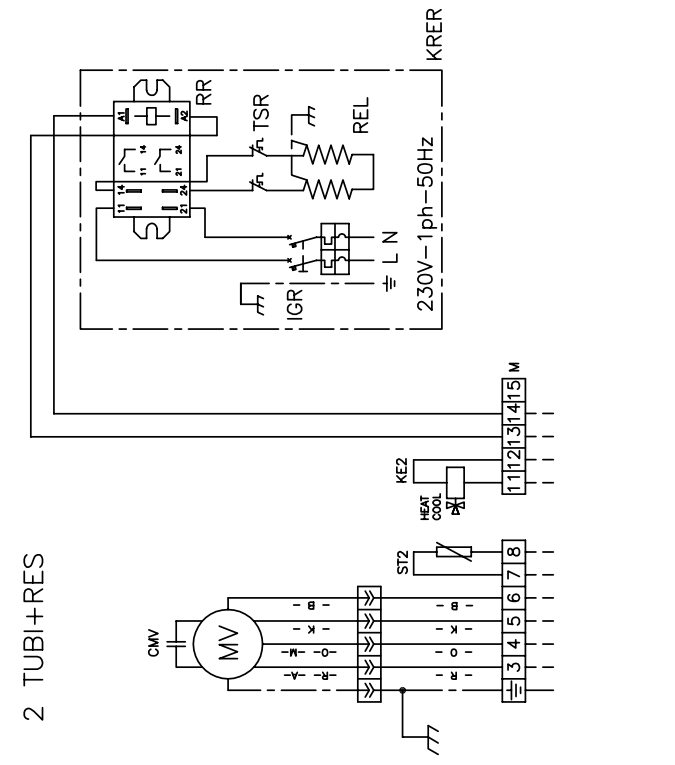

2 TUBI+RES

2 TUBI

4 TUBI

- LEGENDA**
- KTVD Accessorio Termostato
 - CMV Condensatore motore ventilatore
 - M Morsetteria
 - MV Motore ventilatore
 - W1 Sonda temperatura aria
 - ST2 Sonda temperatura acqua
 - KE2 Accessorio Valvola calda/fredda
 - KE4 Accessorio Valvola calda + valvola fredda
 - KRER Accessorio Resistenza elettrica + relais
 - SCR Comando on/off remoto
 - ECO Economy
 - EIR Estate/inverno remoto
 - SIC Sicurezza esterna
 - ALL Allarme esterno
 - Collegamento a cura dell'installatore

Com	Min	Med	Max
-B-	R-	-O-	-K-
Blu	Rosso	Arancio	Nero
	-A-	-M-	
	Grigio	Marrone	

Descrizione/Description	Modelli/Models	Data/Date	Codice
SCHEMA ELETTRICO KTVD-KTVDM ELECTRICAL WIRING KTVD-KTVDM	YARDY 15+88	07-06-18	

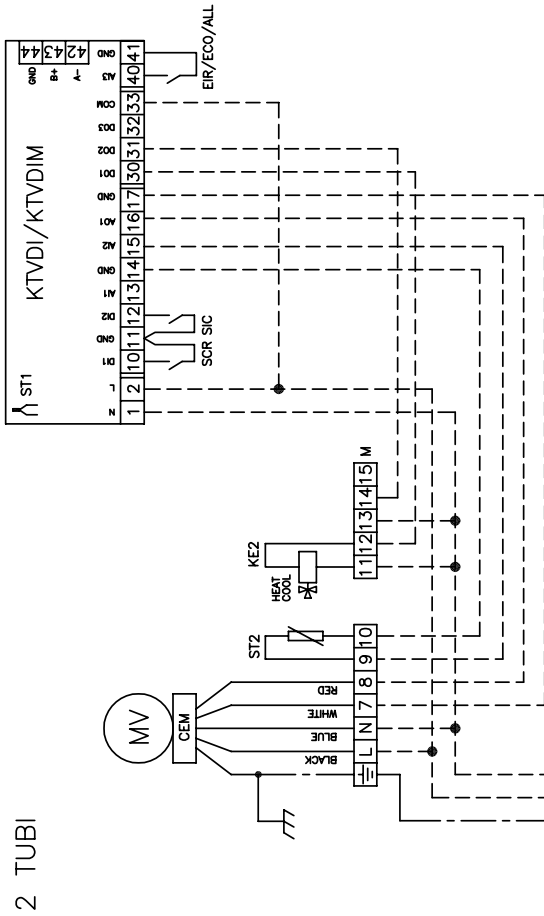
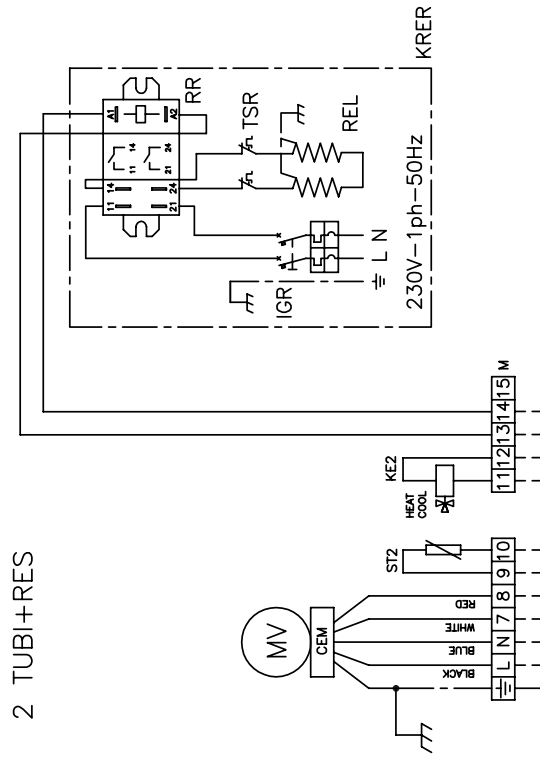

230V-1ph-50Hz

4 TUBI

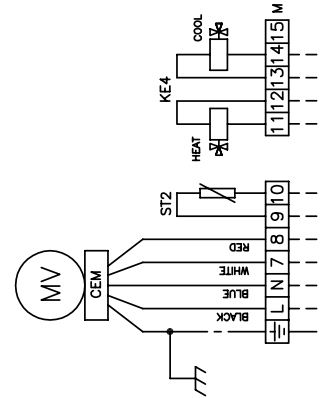

LEGENDA

- KTVDI/KTVDIM Accessorio Termostato
- CEM Controllo elettronico motore
- M Moltiplicatore
- MV Motorizzatore
- ST1 Sonda temperatura aria
- ST2 Sonda minima temperatura acqua (acc. KSO)
- KE2 Accessorio Valvola calda + valvola fredda
- KE4 Accessorio Valvola calda + valvola fredda
- KRER Accessorio Resistenza elettrica + relais
- SCR Comando on/off remoto
- ECO Economy
- EIR Estate/inverno remoto
- SIC Sicurezza esterna
- ALL Allarme esterno
- Collegamento a cura dell'installatore

Descrizione/Description
SCHEMA ELETTRICO KTVDI-KTVDIM
ELECTRICAL WIRING KTVDI-KTVDIM

Modelli/Models
YARDY-I 15+88

Data/Date
07-06-18

Codice

6.2 Advanced controls LIT-TOUCH

System scheme KCF/B, KCF/P+KPLT

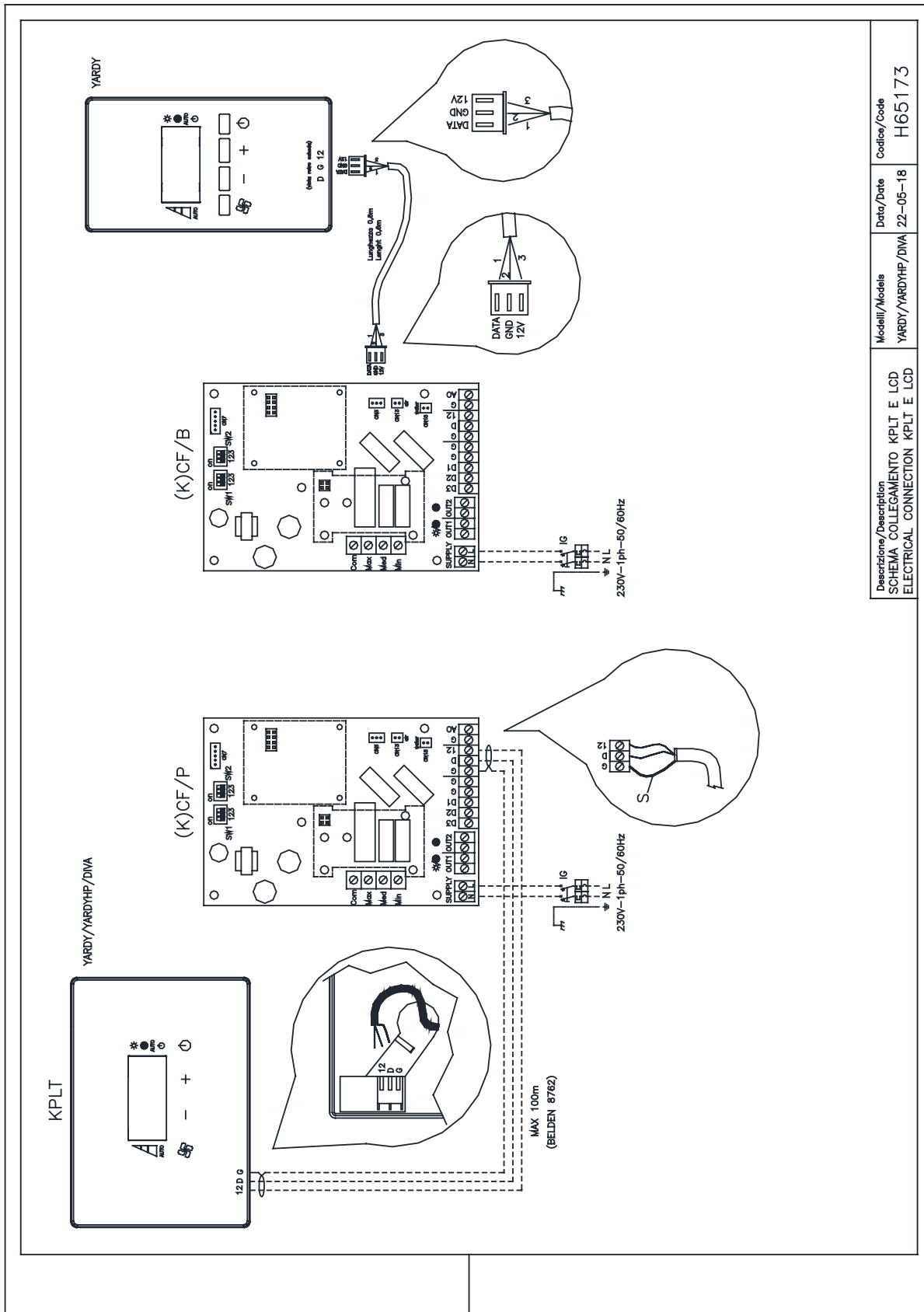

Descrizione/Description SCHEMA COLLEGAMENTO KPLT E LCD ELECTRICAL CONNECTION KPLT E LCD	Model/Models YARDY/YARDHP/DVA	Date/Date 22-05-18	Code/Code H65173
---	----------------------------------	-----------------------	---------------------

KCF	Electronic controls
KPLT	Control panel
KTLT	Remote control
KRLT	Receiver card
IG	General switch
S	Shield of the shielded cable
---	Connection by installer

System scheme KCF/P+KRLT

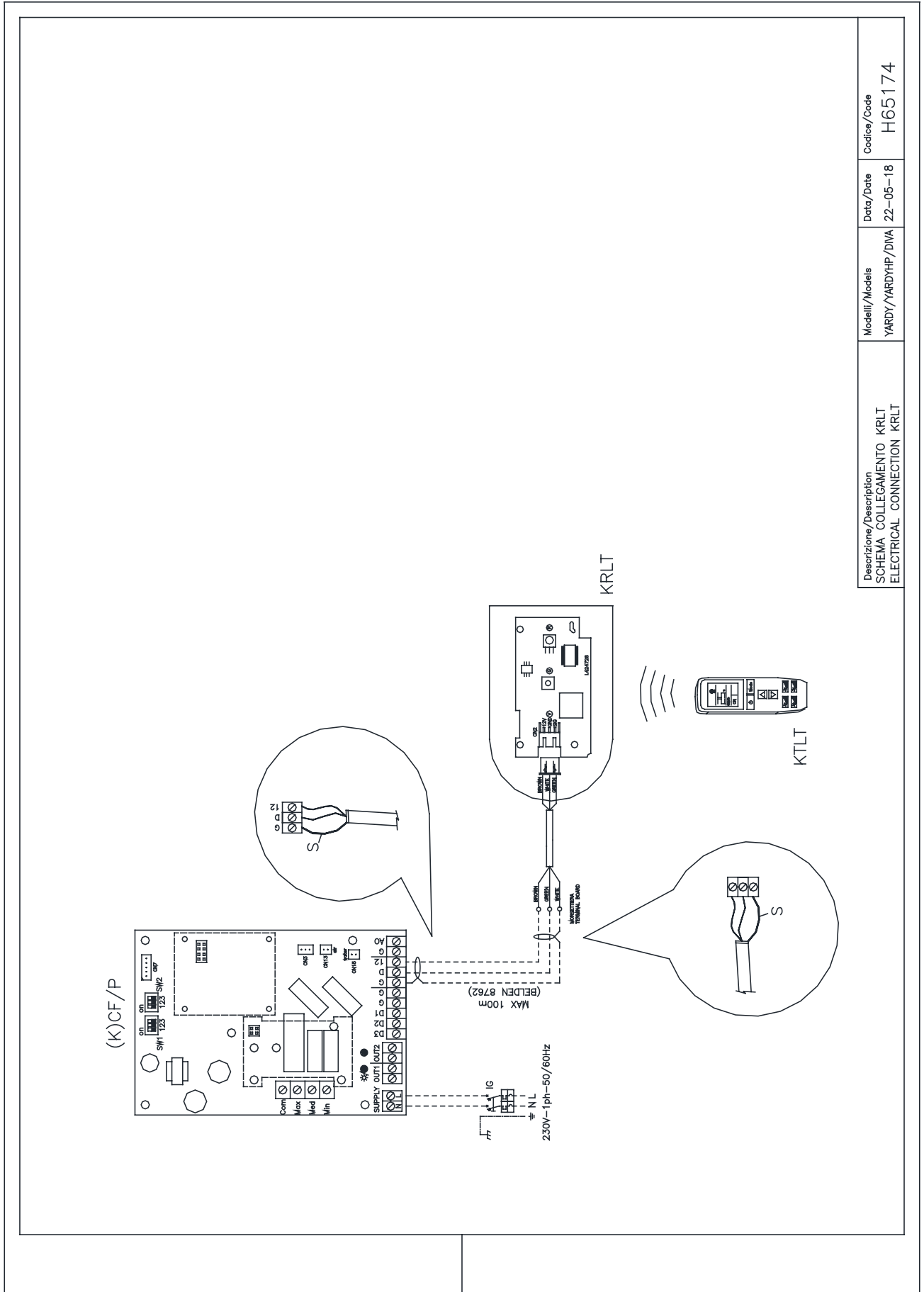

Descrizione/Description	Modelli/Models	Data/Date	Codice/Code
SCHEMA COLLEGAMENTO ELECTRICAL CONNECTION	YARDY/YARDYHP/DIVA	22-05-18	H65174

System scheme KCF/B, KCF/P

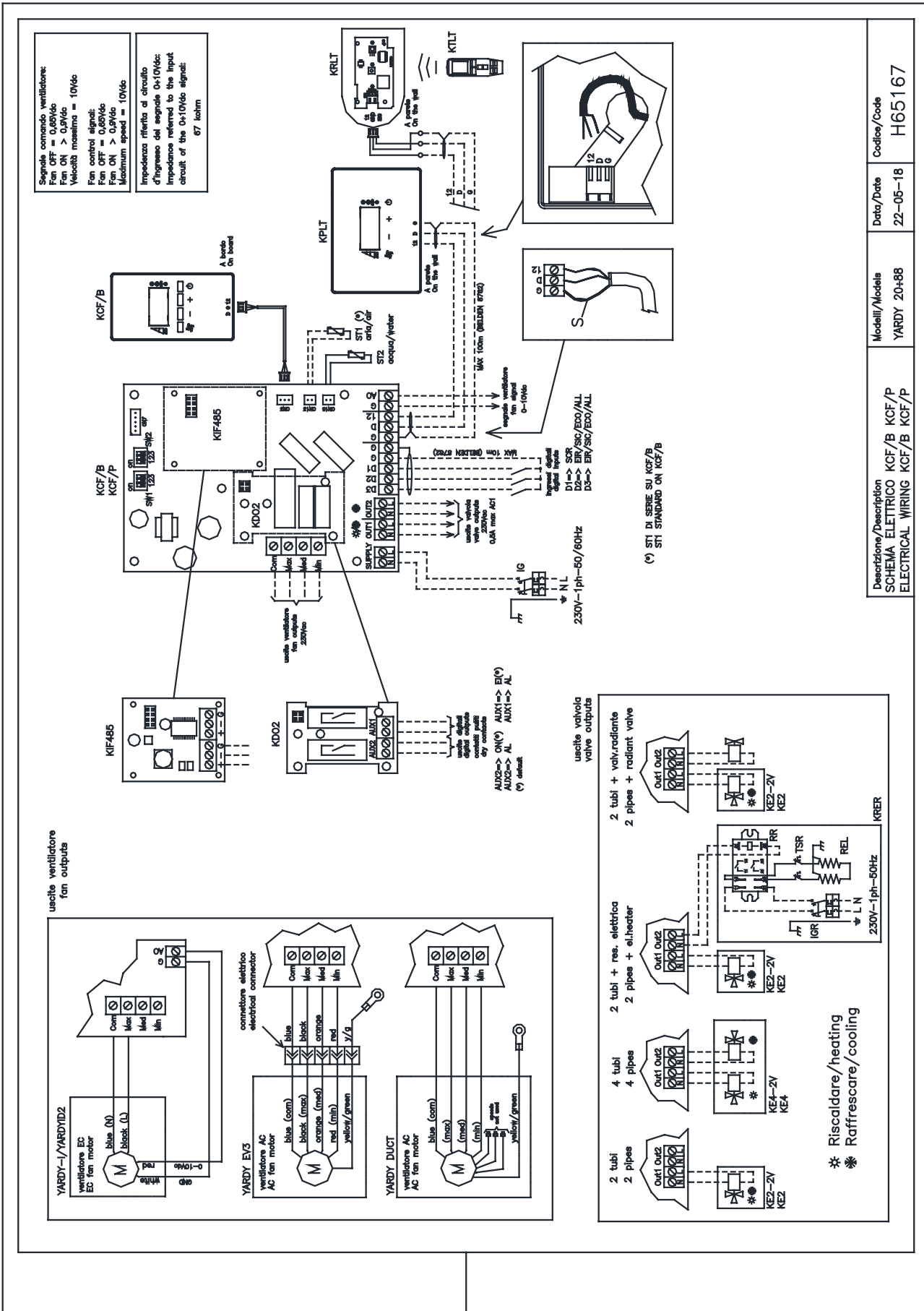

Descrizione/Description SCHEMA ELETTRICO ELECTRICAL WIRING	Modelli/Models YARDY 20+88	Data/Date 22-05-18	Code/Code H65167
--	-------------------------------	-----------------------	---------------------

LEGENDA – LEGEND

YARDY	– Unità base/Base unit
KCF/.	– Controllo elettronico/Electronic control
KPLT	– Pannello comando/Control panel
KTLT	– Telecomando/Remote control
KRLT	– Scheda ricevitore/IR receiver
KDO2	– Scheda uscite digitali/Digital output card
KIF485	– Scheda interfaccia seriale RS485/RS485 serial interface card
KE2..	– Valvola fredda/calda / Cold/hot valve
KE4..	– Valvola calda+fredda/Hot+cold valve
KRER	– Modulo resistenza elettrica/Electrical heater coil module
M	– Motore ventilatore/Fan motor
RR	– Relè resistenza elettrica/Electrical heater relay
REL	– Resistenza elettrica/Electrical heater
TSR	– Termostato sicurezza resistenza elettrica/Electrical heater safety thermostat
IG	– Interruttore generale/General switch
IGR	– Interruttore generale/General switch
L	– Linea/Phase
N	– Neutro/Neutral
SCR	– Selettore comando remoto/Remote control selector
EIR	– Selettore estate/inverno remoto/Summer/winter remote control selector
SIC	– Sicurezza esterna/External safety
ECO	– Selettore funzione economy/Economy function selector
ALL	– Allarme esterno/External alarm
EI	– Uscita modo estate–inverno/Summer–winter mode output
ON	– Uscita richiesta on–off/On–off unit request output
AL	– Uscita allarme/Alarm output
ST1	– Sonda temperatura aria/Air temperature probe
ST2	– Sonda temperatura acqua/Water temperature probe
-----	– Collegamento a cura dell'installatore/Connection by the installer

MASTER / SLAVE connection diagram with on-board control panel

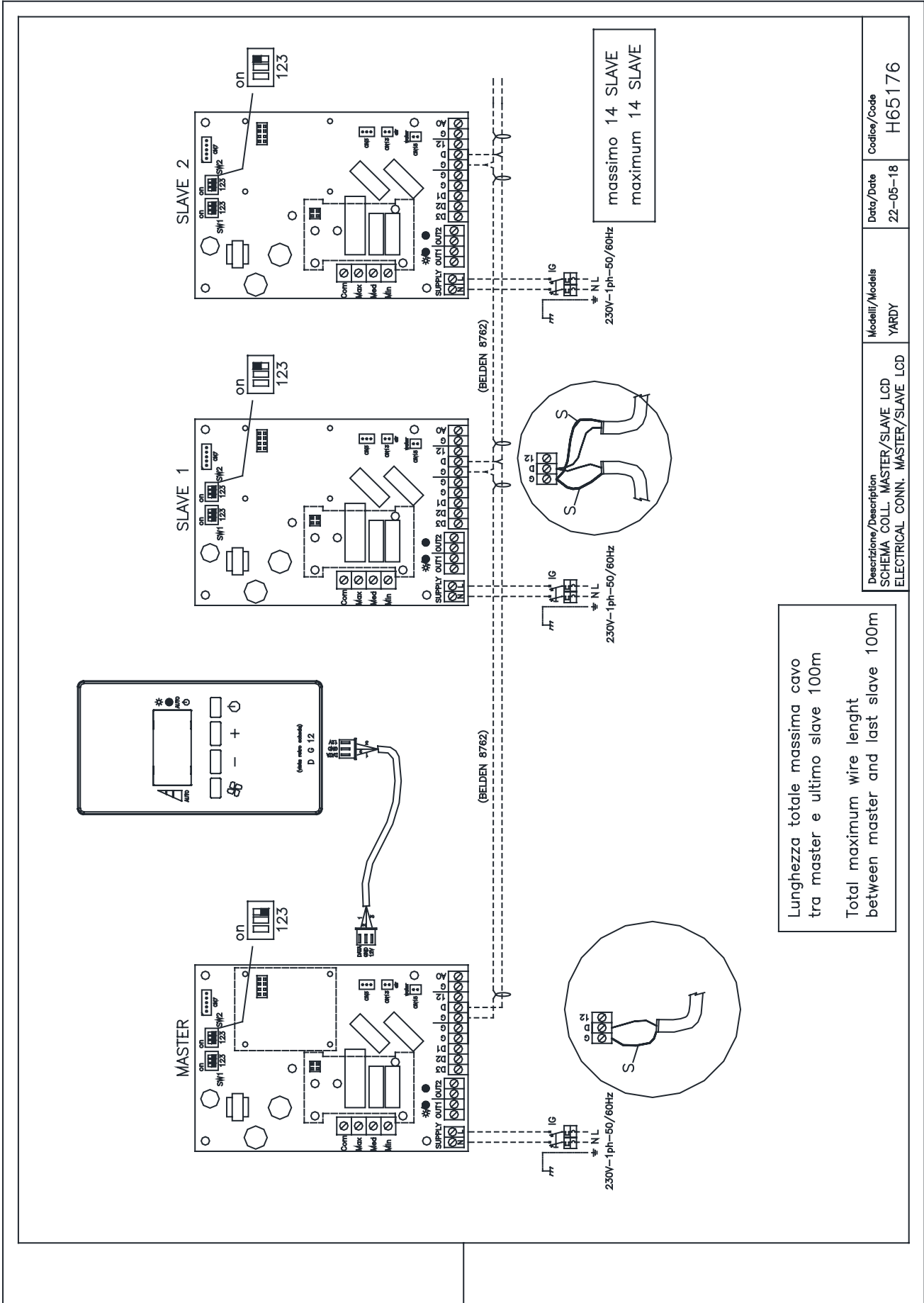

Description/Description	Modelli/Models	Data/Date	Code/Code
SCHEMA COLL. MASTER/SLAVE LCD ELECTRICAL CONN. MASTER/SLAVE LCD	YARDY	22-05-18	H65176

Lunghezza totale massima cavo
tra master e ultimo slave 100m
Total maximum wire length
between master and last slave 100m

massimo 14 SLAVE
maximum 14 SLAVE

MASTER / SLAVE connection diagram with wall control panel (KPLT)

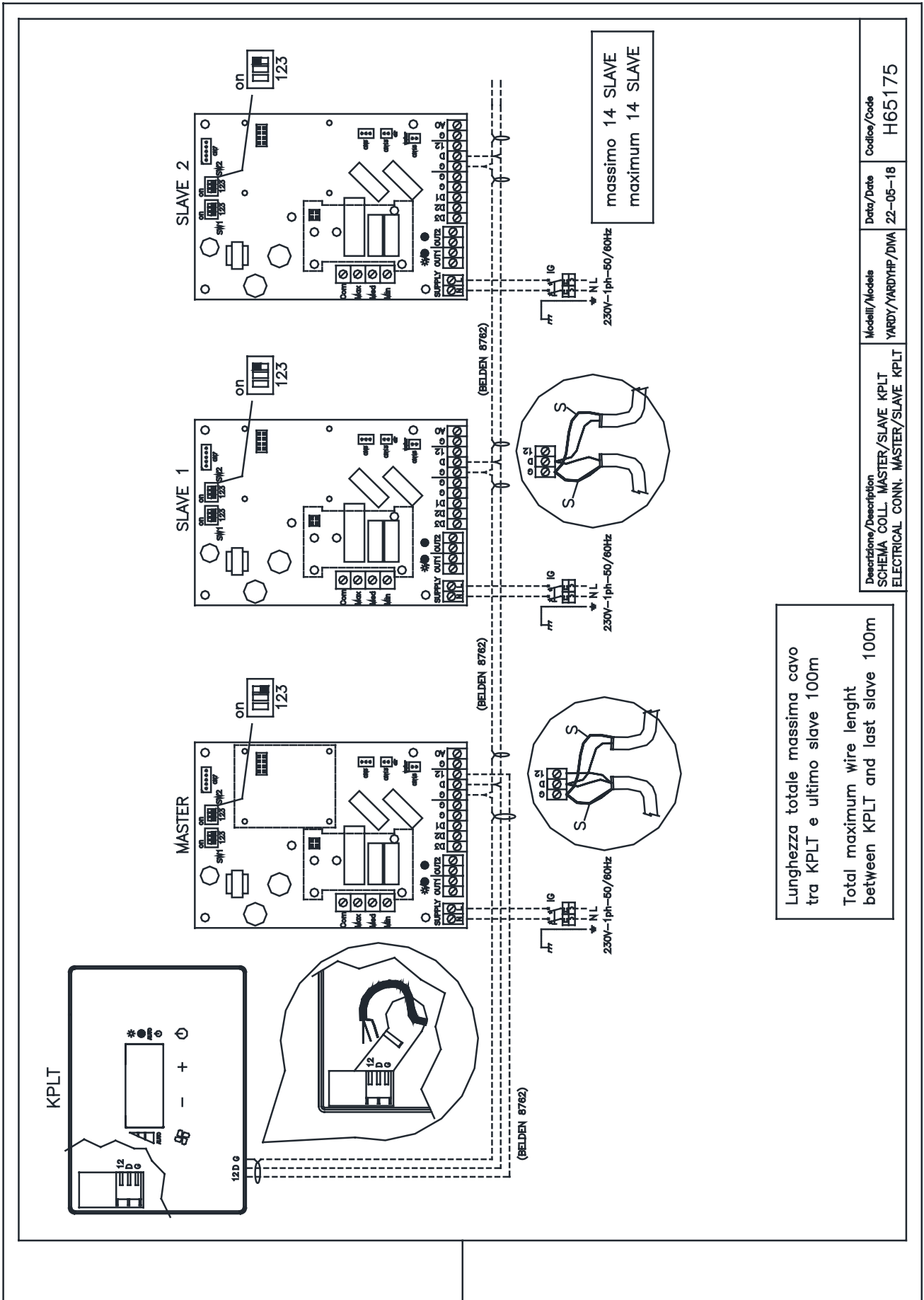

Descrizione/Description	Modello/Model	Data/Date	Codice/Code
SCHEMA COLL. MASTER/SLAVE KPLT ELECTRICAL CONN. MASTER/SLAVE KPLT	YARDY/YARDYHP/DIVA	22-05-18	H65175

MASTER / SLAVE connection diagram with remote control

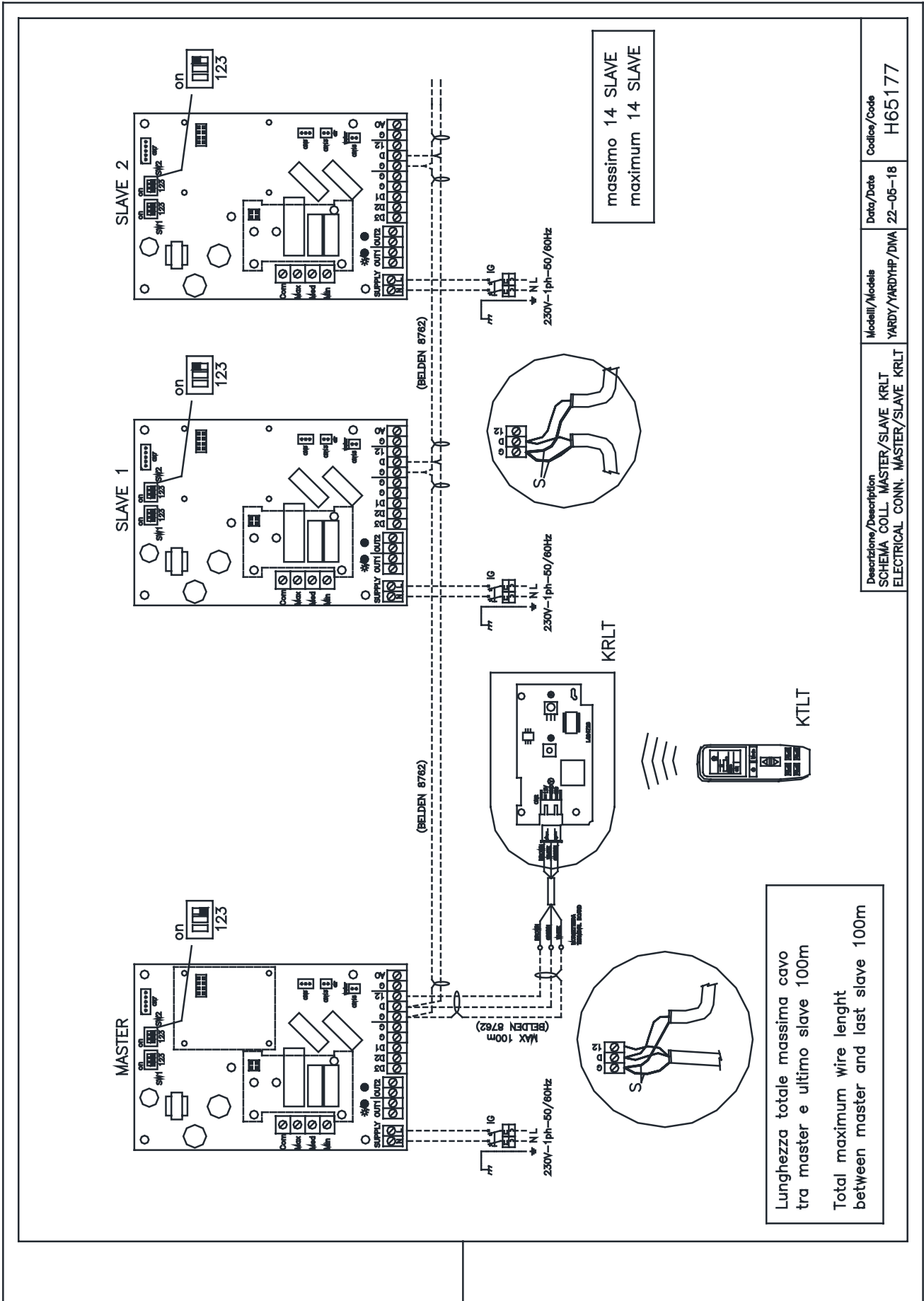

Model/Models	YARDY/YARDYHP/DIVA	Code/Code	H65177
Date/Date	22-05-18		
Description/Description	SCHEMA COLL. MASTER/SLAVE KRLT ELECTRICAL CONN. MASTER/SLAVE KRLT		

Centralized digital input connection scheme

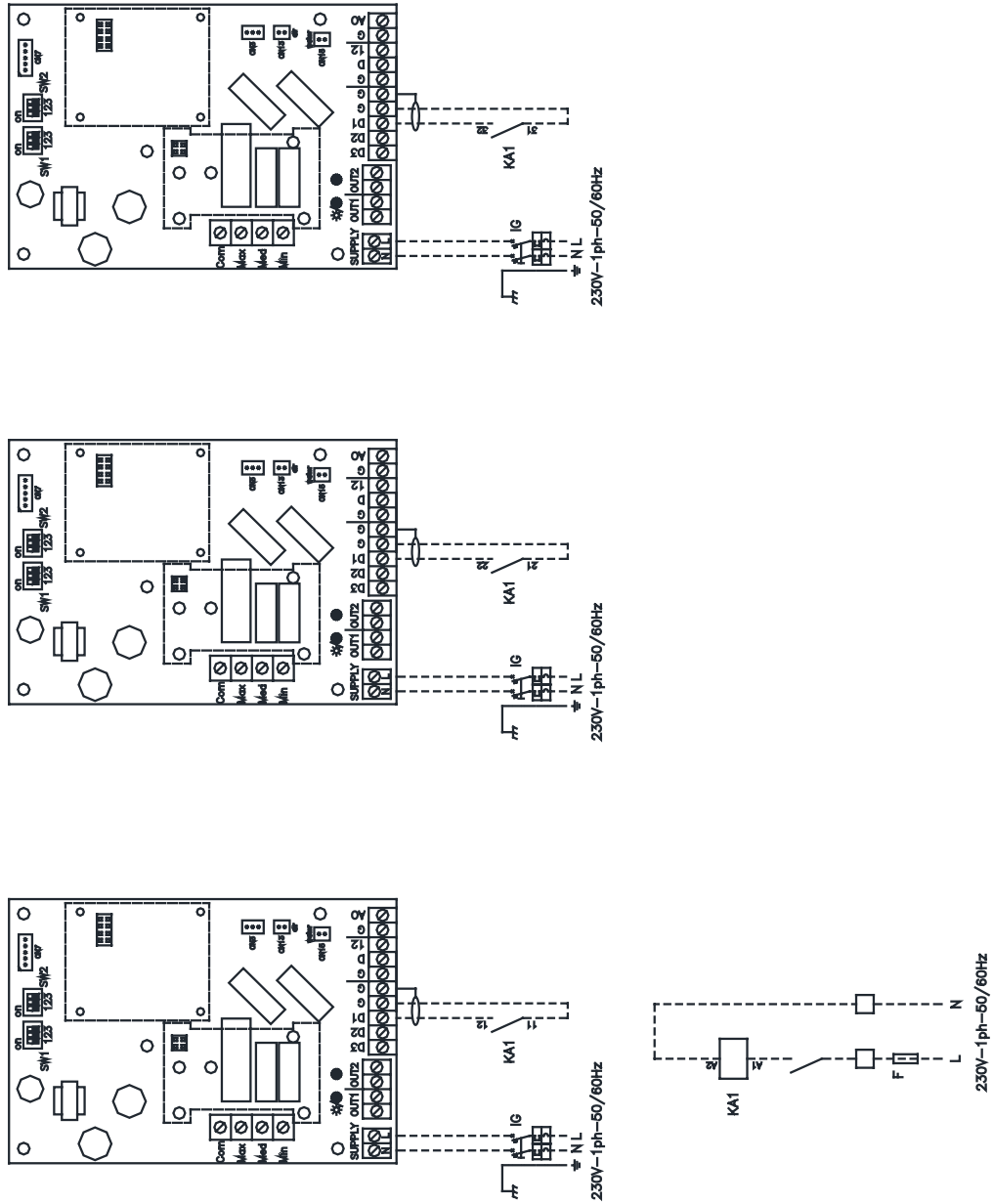

NOTE

Same connection type for SIC, EIR and ECO

Descrizione/Description SCHEMA COLLEGAMENTO INGRESSI DIGITALI ELECTRICAL CONNECTION DIGITAL INPUT	Modelli/Models YARDY/YARDYHP/DIVA	Data/Date 22-05-18	Codice/Code H65179
---	--------------------------------------	-----------------------	-----------------------

7. DIVA - DIVA-I connection

DIVA connection (standard electrical connection)

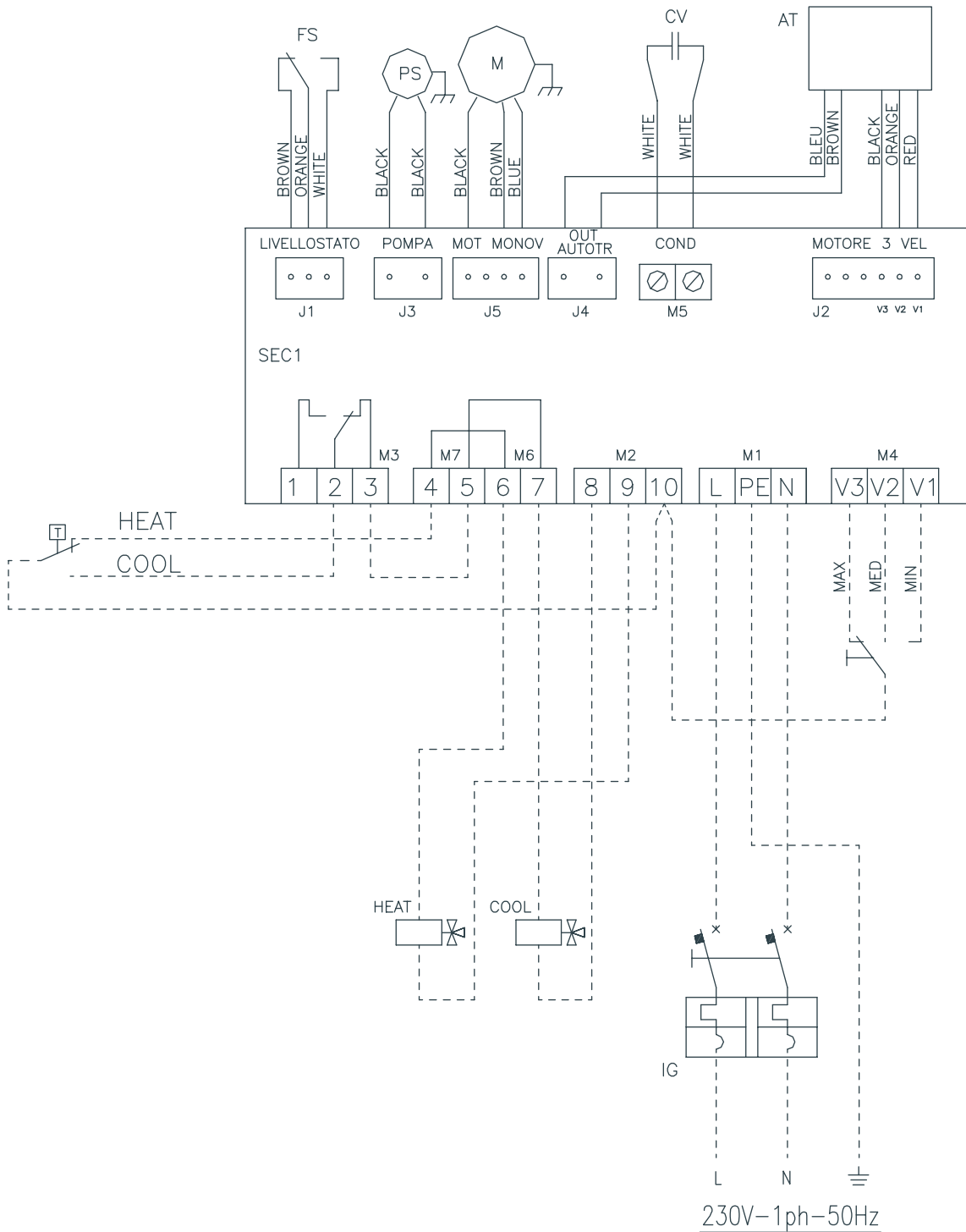

IG	General automatic switch
L	Phase
N	Neutral
----	Connections by installer

DIVA+KCV2

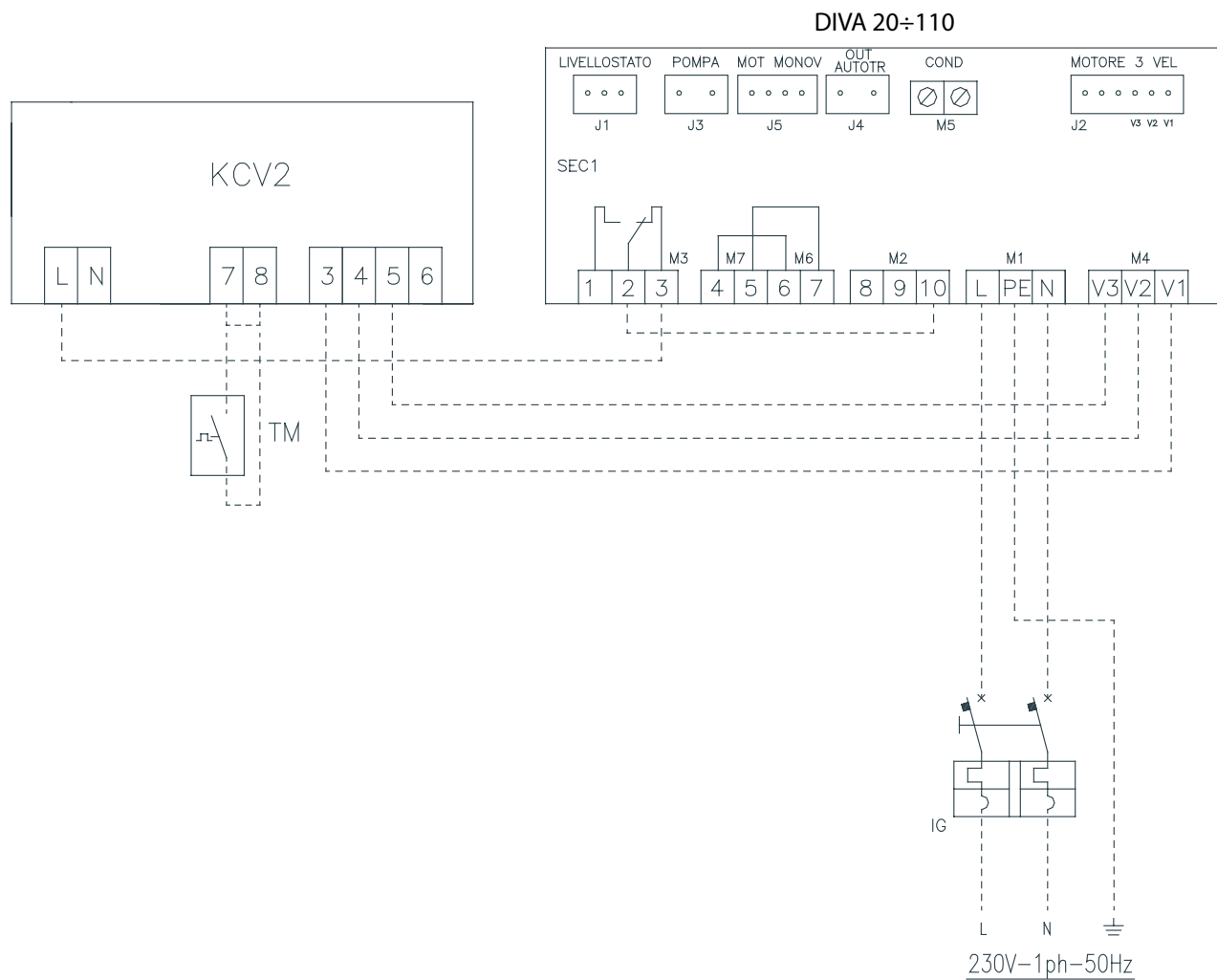

DIVA	Basic unit
KCV2	Control panel
IG	General automatic switch
TM	Minimum thermostat
L	Phase
N	Neutral
---	Connections by installer

DIVA+KTCV2

DIVA 2T 20÷110

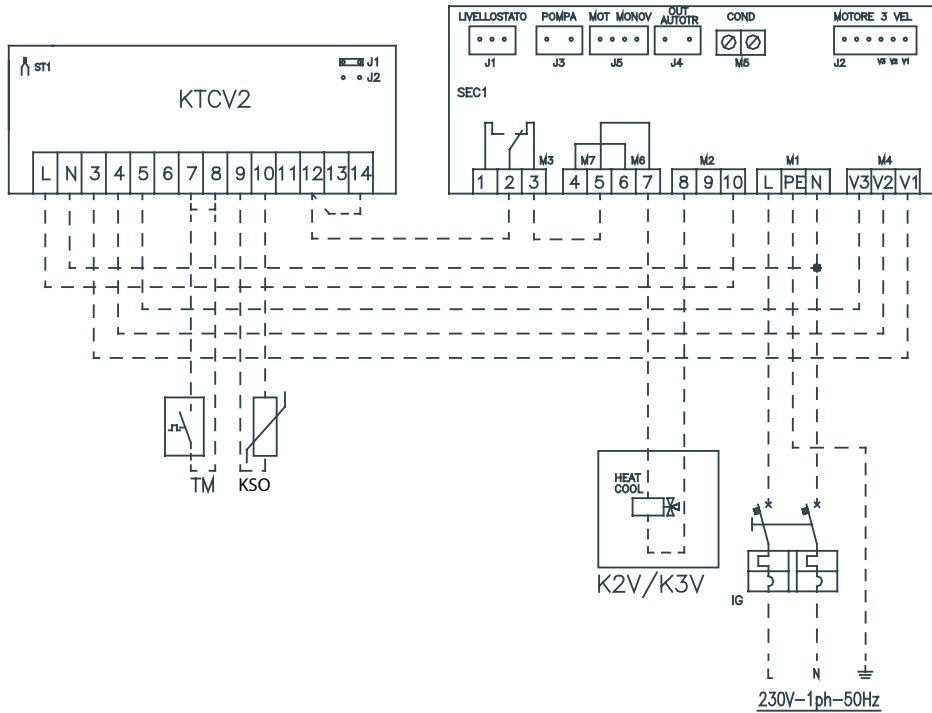

DIVA 4T 20÷110

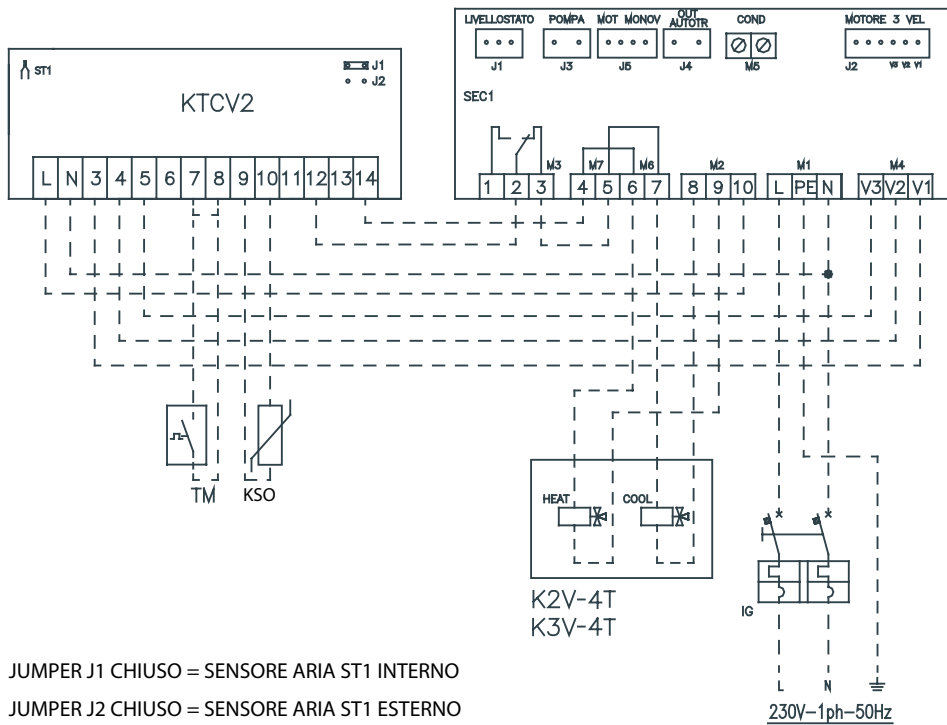

- JUMPER J1 CHIUSO = SENSORE ARIA ST1 INTERNO
- JUMPER J2 CHIUSO = SENSORE ARIA ST1 ESTERNO
- JUMPER J1 CLOSED = ST1 AIR PROBE INTERNAL
- JUMPER J2 CLOSED = ST1 AIR PROBE EXTERNAL

DIVA RE 2T+R 30±110

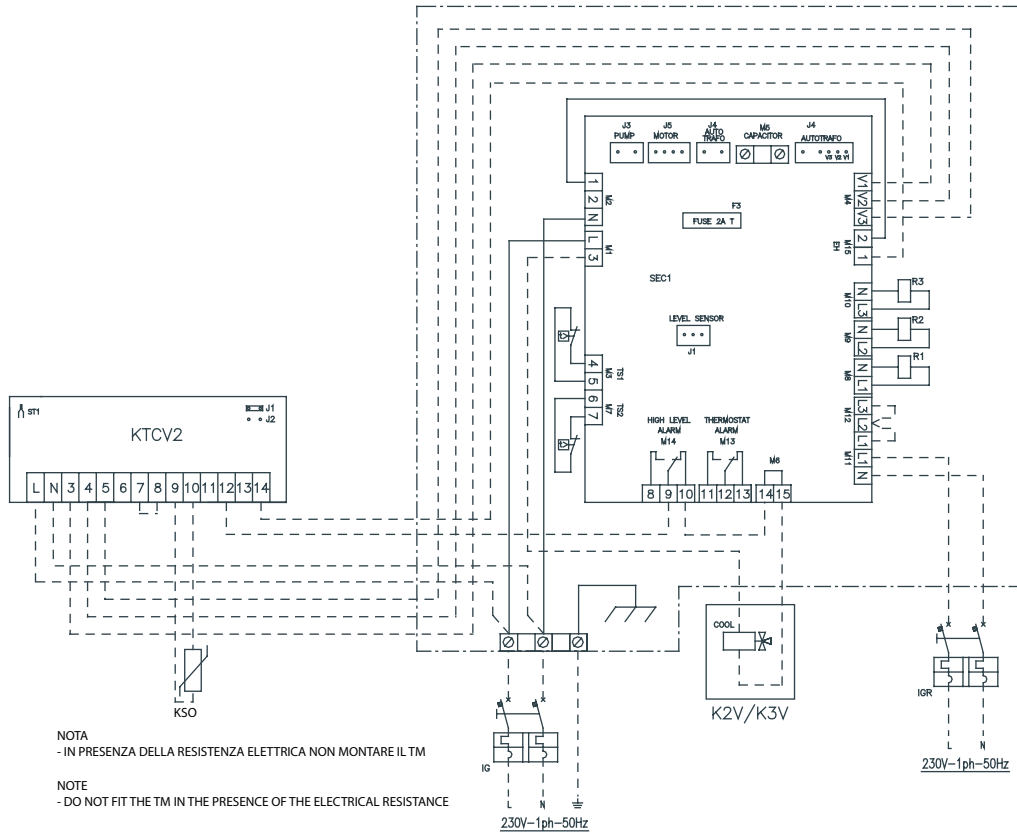

LEGENDA/LEGEND

- DIVA - Unità base/Base unit
- KTCV2 - Pannello comando/Control panel
- K2V /K3V - Valvola calda-fredda/Hot-cold valve
- K2VB4-K3VB4 - Valvola calda+fredda/Hot+cold valve
- R1-2-3 - Relè resistenza elettrica/Electrical heater contactor
- TS1-2 - Termostato sicurezza resistenza/Electrical heater safety thermostat
- ST1 - Sonda temperatura aria/Air temperature probe
- KSO - Sonda temperatura aria remota/Remote air temperature probe
- IG - Interruttore automatico generale/General automatic switch
- IGR - Interruttore automatico resistenza/El. heater automatic switch
- TM - Termostato di minima/Minimum temp. thermostat
- L - Fase/Phase
- N - Neutro/Neutral
- - Collegamento a cura dell'installatore/Connection by installer

JUMPER J1 CHIUSO = SENSORE ARIA ST1 INTERNO

JUMPER J2 CHIUSO = SENSORE ARIA ST1 ESTERNO

JUMPER J1 CLOSED = ST1 AIR PROBE INTERNAL

JUMPER J2 CLOSED = ST1 AIR PROBE EXTERNAL

DIVA+KTCVA

DIVA 2T 20÷110

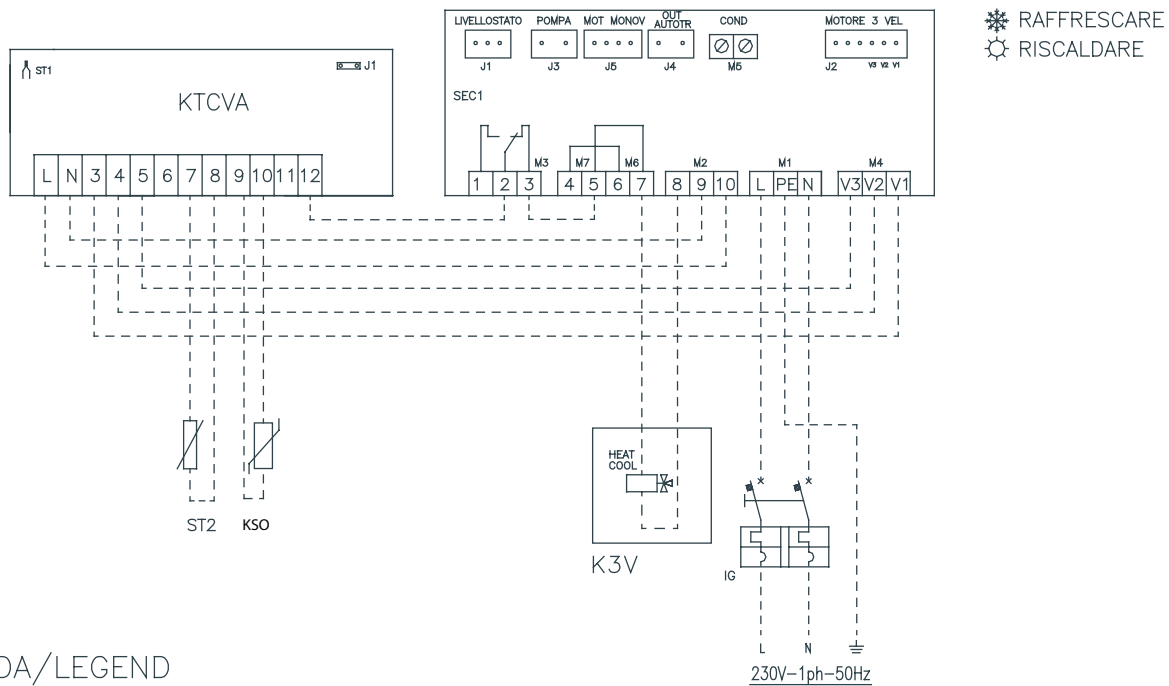

LEGENDA/LEGEND

- DIVA – Unità base/Base unit
- KTCVA – Pannello comando/Control panel
- K3V – Valvola calda-fredda/Hot-cold valve
- ST1 – Sonda temperatura aria/Air temperature probe
- ST2 – Sonda temperatura acqua/Water temperature probe
- KSO – Sonda temperatura aria remota/Remote air temperature probe
- IG – Interruttore automatico generale/General automatic switch
- L – Fase/Phase
- N – Neutro/Neutral
- – Collegamento a cura dell'installatore/Connection by installer

- JUMPER J1 CHIUSO = SENSORE ARIA ST1 INTERNO
- JUMPER J1 APERTO = SENSORE ARIA ST1 ESTERNO
- JUMPER J1 CLOSED = ST1 AIR PROBE INTERNAL
- JUMPER J1 OPENED = ST1 AIR PROBE EXTERNAL

- NOTA
- LA SONDA ACQUA ST2 È COMPRESA NELL'IMBALLO DEL TERMOSTATO
 - IN CASO DI PRESENZA DELLA VALVOLA 3 VIE ON/OFF, LA SONDA ACQUA ST 2 DEVE ESSERE POSTA A MONTE DELLA VALVOLA STESSA
 - THE ST2 WATER PROBE IS INCLUDED IN THE THERMOSTAT PACKAGE
 - THE ST2 WATER PROBE MUST BE FITTED UPSTREAM THE ON/OFF 3-WAY VALVE IF THIS IS PRESENT

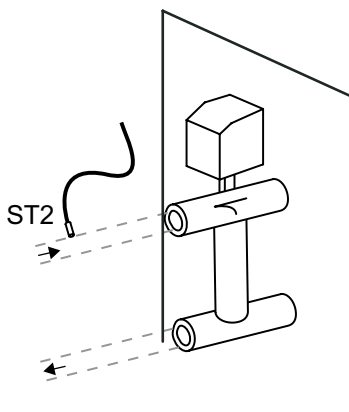
NOTE: the control does not work with a 2-way valve



DIVA+KTCVR (2T+R)

❄️ RAFFRESCARE
☀️ RISCALDARE

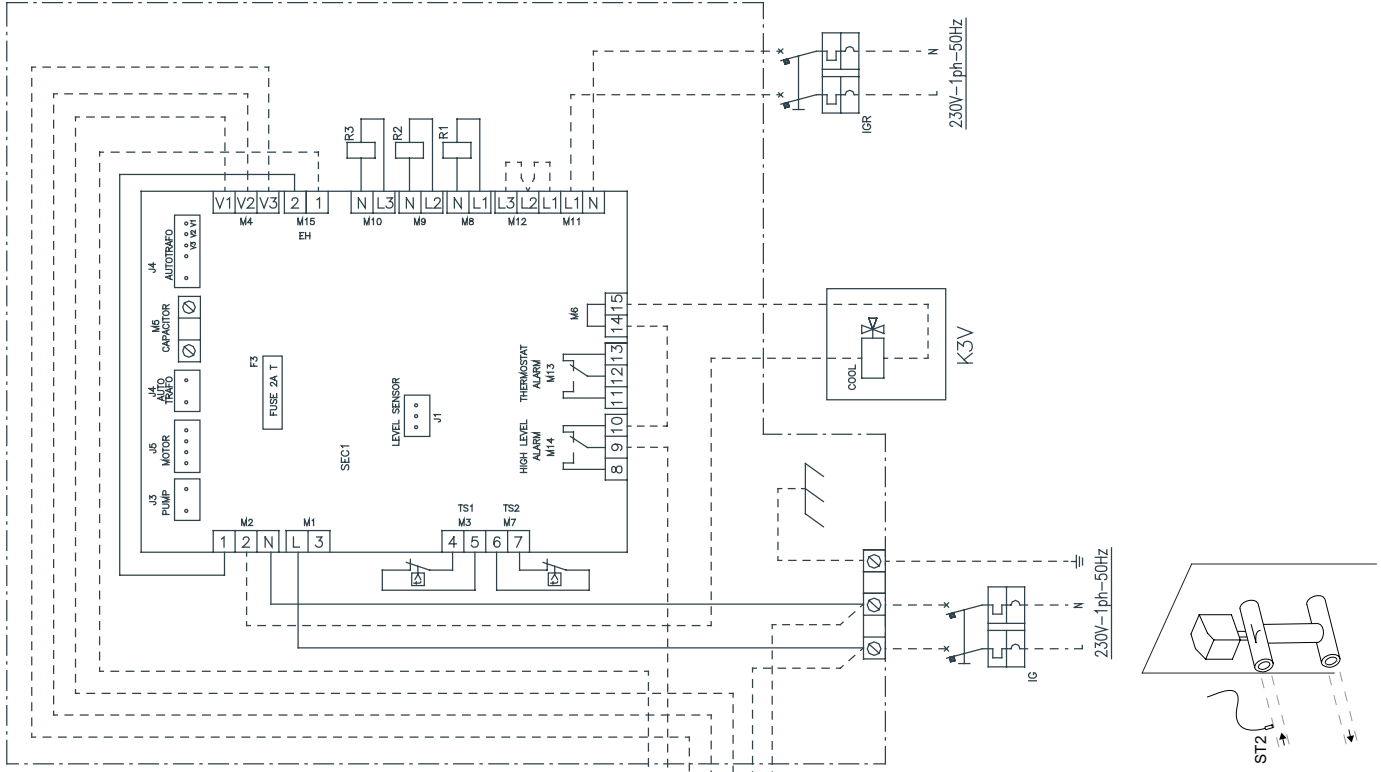

DIVA RE 2T+R 30÷110

- JUMPER J1 CHIUSO = SONDA ARIA ST1 INTERNA
- JUMPER J1 APERTO = SONDA ARIA ST1 ESTERNA
- JUMPER J2 CHIUSO = IMPIANTO A 4 TUBI
- JUMPER J2 APERTO = IMPIANTO A 2 TUBI (2 TUBI+ RESISTENZA)

- JUMPER J1 CHIUSO = INTERNAL ST1 AIR PROBE
- JUMPER J1 APERTO = EXTERNAL ST1 AIR PROBE
- JUMPER J2 CHIUSO = 4 PIPE SYSTEM
- JUMPER J2 APERTO = 2 PIPE SYSTEM (2 PIPES + RESISTANCE)

NOTA

LA SONDA ACQUA ST2 È COMPRESA NELL'IMBALLO DEL TERMOSTATO.
IMPIANTO A 2 TUBI (2 TUBI + RE) JUMPER J2 APERTO E SONDA ACQUA ST2 A MONTE VALVOLA 3VIE (SE PRESENTE) *
IMPIANTO A 4 TUBI JUMPER J2 CHIUSO E SONDA ACQUA ST2 POSIZIONATA SULLA BATTERIA CALDA (CON O SENZA VALVOLA)

THE ST2 WATER PROBE IS INCLUDED IN THE THERMOSTAT PACKAGE.
2-PIPE SYSTEM (2 PIPES + RE) JUMPER J2 OPEN AND ST2 WATER PROBE UPSTREAM THE 3-WAY VALVE (IF PRESENT) *
4-PIPE SYSTEM JUMPER J2 CLOSED AND ST2 WATER PROBE PLACED ON THE HOT COIL (WITH OR WITHOUT THE VALVE)

NOTE: the control does not work with a 2-way valve

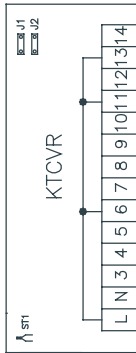

LEGENDA/LEGEND

- DIVA - Unità base/Base unit
- KTCVR - Pannello comando/Control panel
- K3V - Valvola calda-fredda/Hot-cold valve
- R1-2-3 - Relè resistenza elettrica/Electrical heater safety thermostat
- TS1-2 - Termostato sicurezza resistenza/Electrical heater safety thermostat
- ST1 - Sonda temperatura aria/Air temperature probe
- ST2 - Sonda temperatura acqua/Water temperature probe
- KSO - Sonda temperatura aria remota/Remote air temperature probe
- IG - Interruttore automatico generale/General automatic switch
- IGR - Interruttore automatico resistenza/El. heater automatic switch
- L - Fase/Phase
- N - Neutro/Neutral
-
- Collegamento a cura dell'installatore/Connection by installer

DIVA+KTVD/KTVDM

DIVA 4T 20÷110

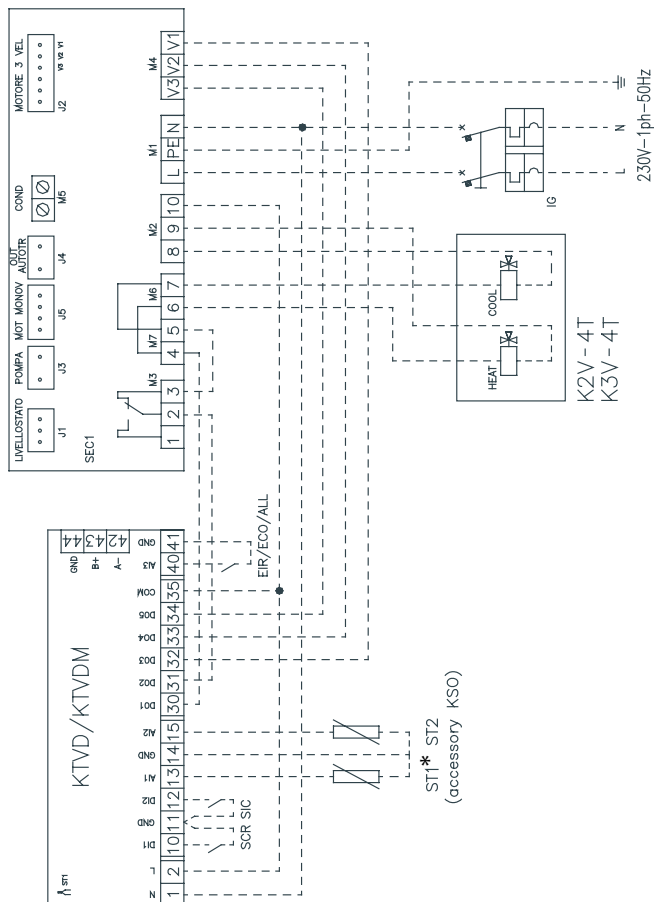

DIVA 2T 20÷110

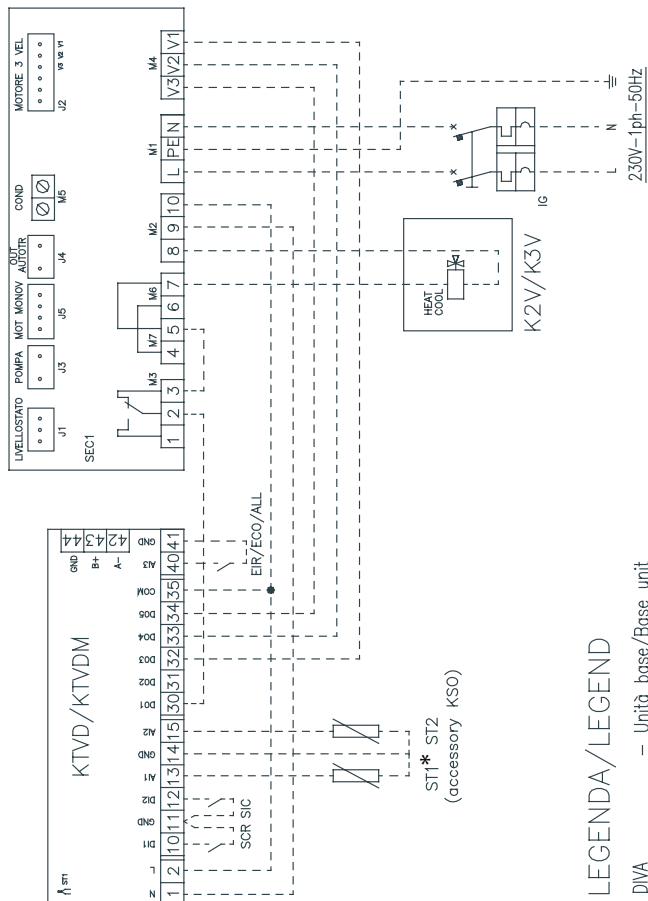

LEGENDA/LEGEND

- DIVA – Unità base/Base unit
- KTVD/KTVDM – Pannello comando/Control panel
- K2V/K3V – Valvola calda-fredda/Hot-cold valve
- K2V-4T/K3V-4T – Valvola calda+fredda/Hot+cold valve
- SCR – Selettore comando remoto/Remote control selector
- SIC – Sicurezza esterna/External safety
- EIR – Selettore estate/inverno remoto/Summer/winter remote selector
- ECO – Selettore funzione economy/Economy function selector
- ALL – Ingresso allarme/Alarm input
- ST1 – Sonda temperatura aria/Air temperature probe
- ST1* – Sonda temperatura aria remota (KSO)/Remote air temperature probe (KSO)
- ST2 – Sonda temperatura acqua calda (KSO)/Hot water temperature probe (KSO)
- IG – Interruttore automatico generale/General automatic switch
- L – Fase/Phase
- N – Neutro/Neutral
- Collegamento a cura dell'installatore/Connection by installer

DIVA+KTVD/KTVDM

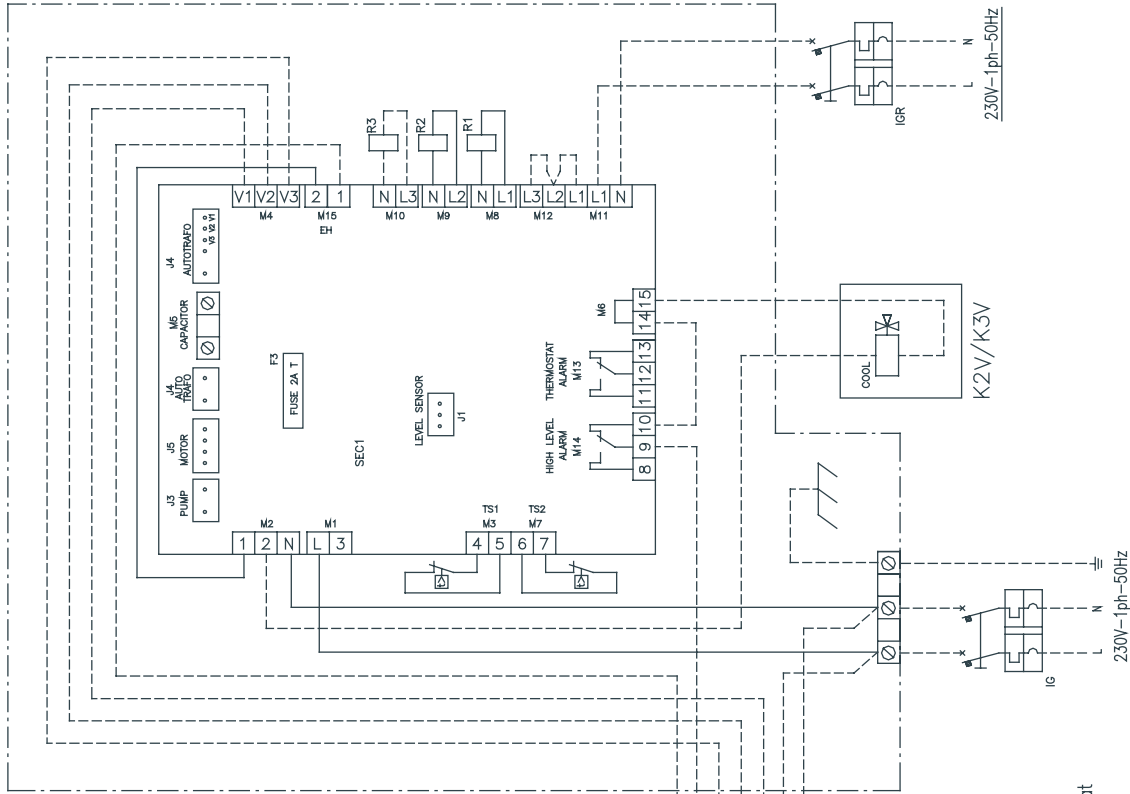

DIVA RE 2T+R 30÷110

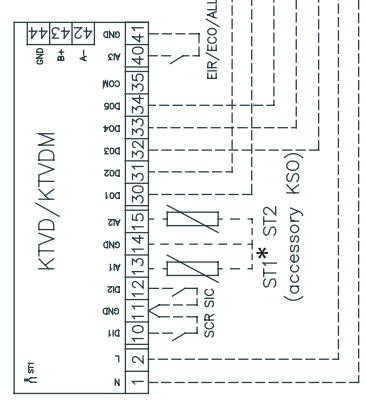

LEGENDA/LEGEND

- DIVA - Unità base/Base unit
- KTVD/KTVDM - Pannello comando/Control panel
- K2V/K3V - Valvola fredda/Cold valve
- R1-2-3 - Relè resistenza elettrica/Electrica heater contactor
- TS1/TS2 - Termostato sicurezza resistenza/Electrical heater safety thermostat
- SCR - Selettore comando remoto/Remote control selector
- SIC - Sicurezza esterna/External safety
- EIR - Selettore estate/inverno remoto/Summer/winter remote selector
- ECO - Selettore funzione economy/Economy function selector
- ALL - Ingresso allarme/Alarm input
- ST1 - Sonda temperatura aria/Air temperature probe
- ST1* - **Sonda temperatura aria remota (KSO)/Remote air temperature probe (KSO)**
- ST2 - Sonda temperatura acqua calda (KSO)/Hot water temperature probe (KSO)
- IG - Interruttore automatico generale/General automatic switch
- IGR - Interruttore automatico resistenza/El. heater automatic switch
- L - Fase/Phase
- N - Neutro/Neutral
- Collegamento a cura dell'installatore/Connection by installer

Electrical connection of advanced controls DIVA: KCF / P

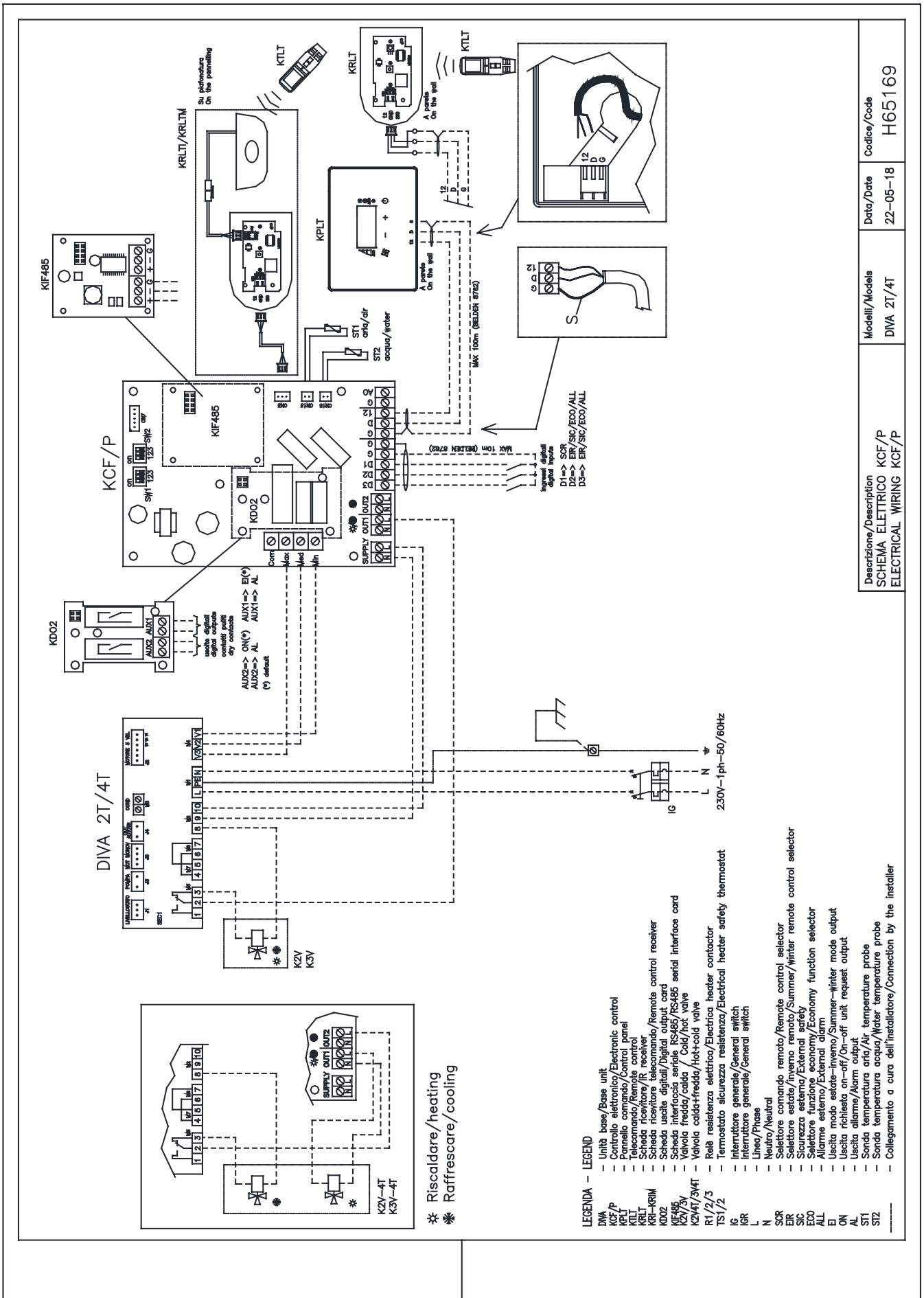

Descrizione/Description SCHEMA ELETTRICO KCF/P ELECTRICAL WIRING KCF/P	Modelli/Models DIVA 2T/4T	Data/Date 22-05-18	Codice/Code H65169
--	------------------------------	-----------------------	-----------------------

Electrical connection of advanced controls DIVA RE: KCF/P

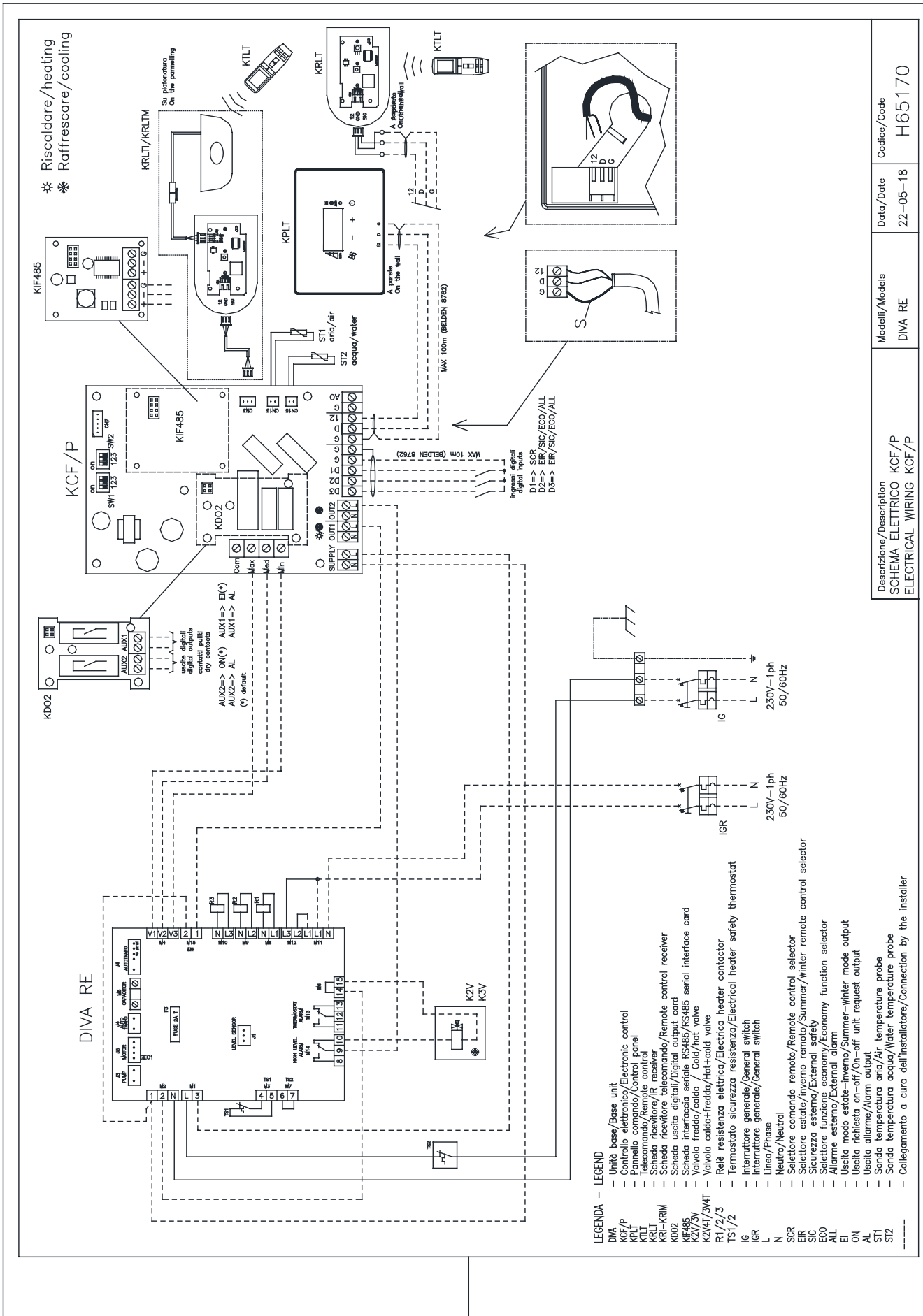

Descrizione/Description	SCHEMA ELETTRICO KCF/P ELECTRICAL WIRING KCF/P
Modelli/Models	DIVA RE
Data/Date	22-05-18
Code/Code	H65170

DIVA-I

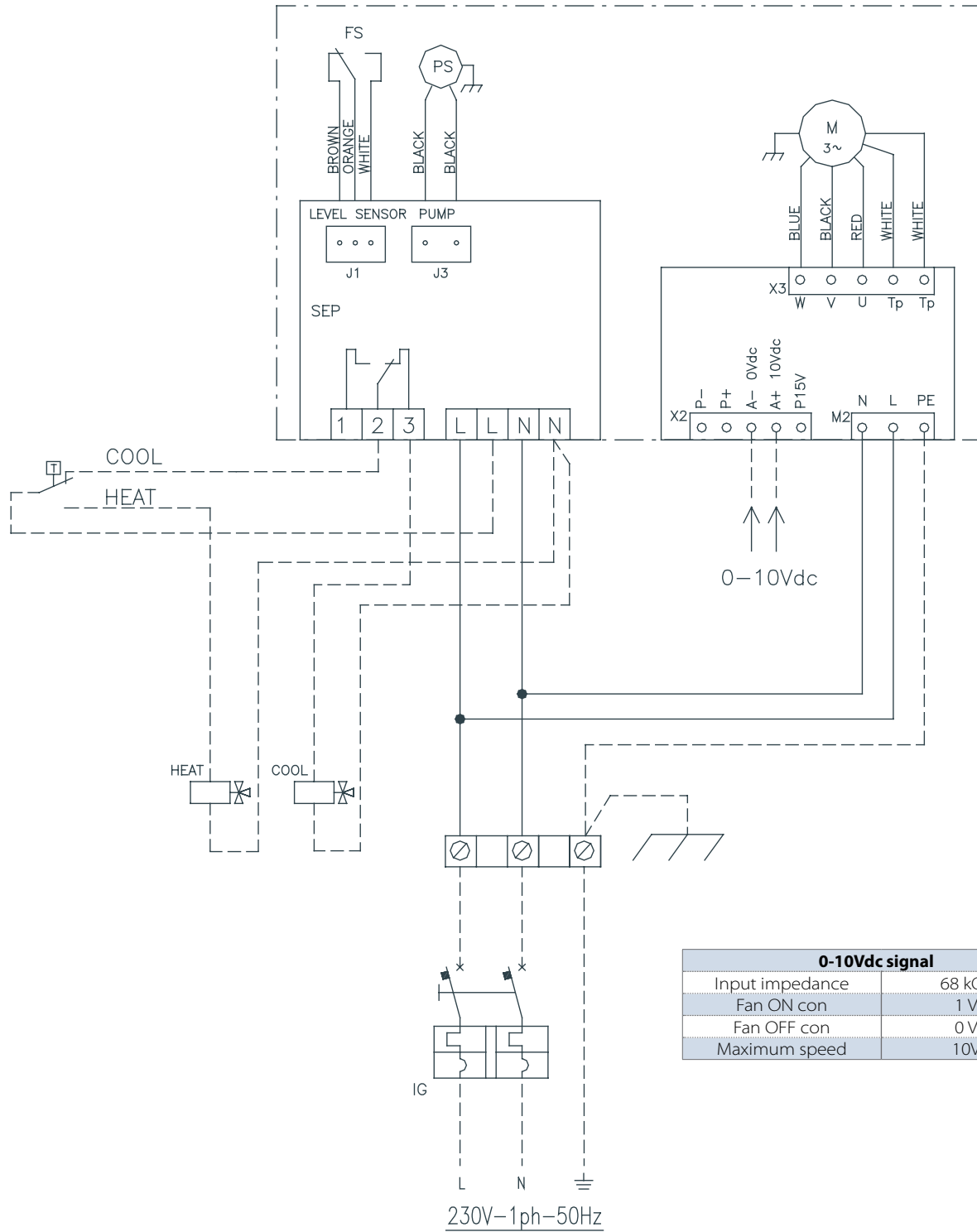

0-10Vdc signal	
Input impedance	68 kOhm
Fan ON con	1 Vdc
Fan OFF con	0 Vdc
Maximum speed	10Vdc

IG	General automatic switch
L	Phase
N	Neutral
----	Connections by installer

DIVA-I + KTVDI/KTVDIM

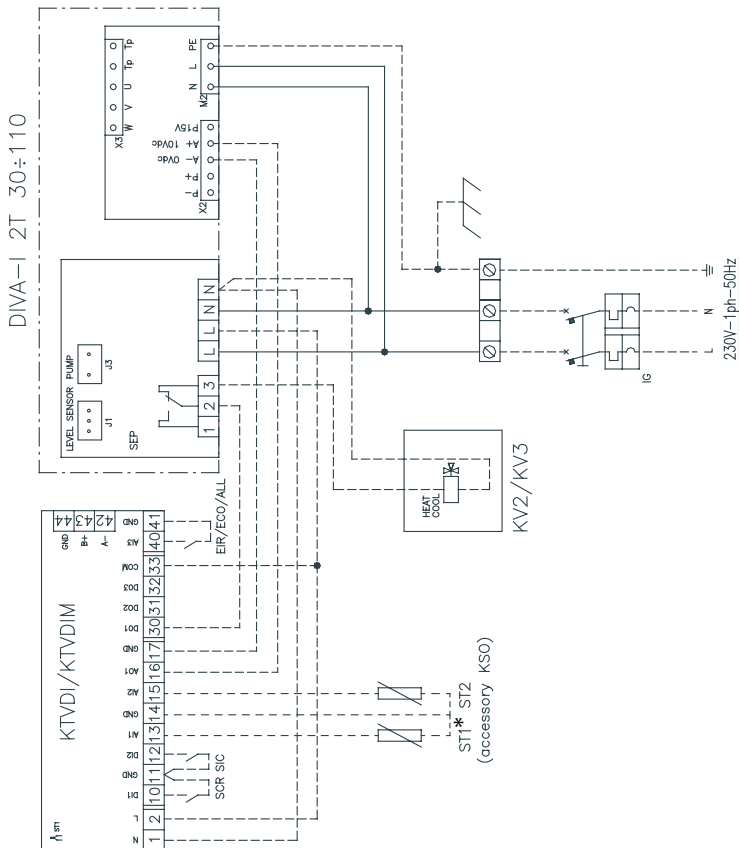
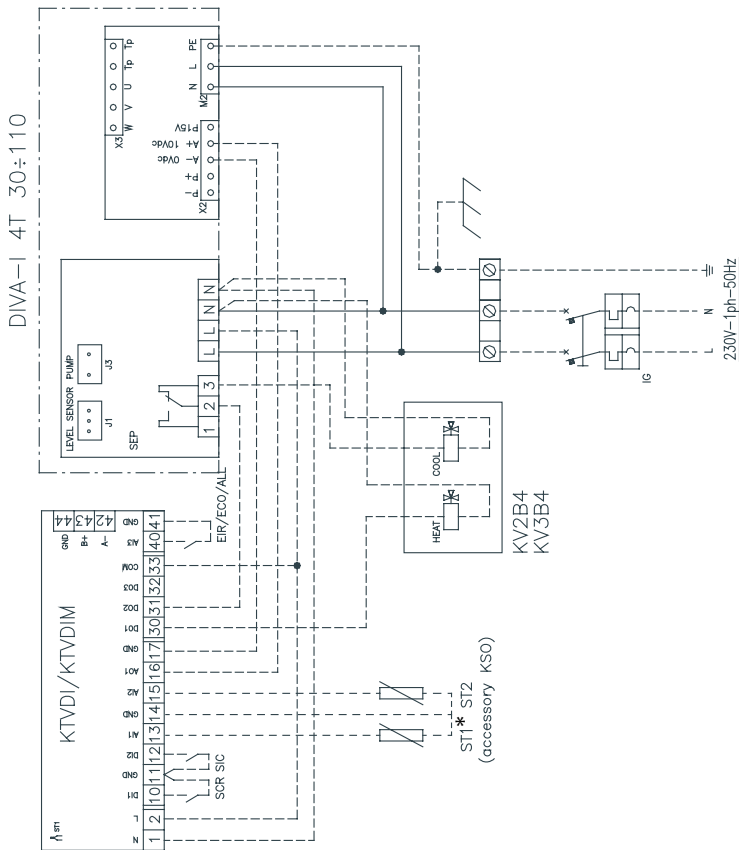

DIVA-I	Basic unit
KTVDI/KTVDIM	Control panel
KV2/KV3	Hot-cold valve
KV2B4/KV3B4	Hot + cold valve
SCR	Remote control selector
SIC	External security
EIR	Remote Summer/Winter
ECO	Economy function selector
ALL	Alarm input
ST1	Air temperature probe
ST1 *	Remote air temperature probe (KSO)
ST2	Hot water temperature probe
IG	General automatic switch
L	Phase
Water outlet	Neutral
----	Connections by installer

Electrical connection of advanced controls DIVA - DIVA-I: KC/P + KRLT

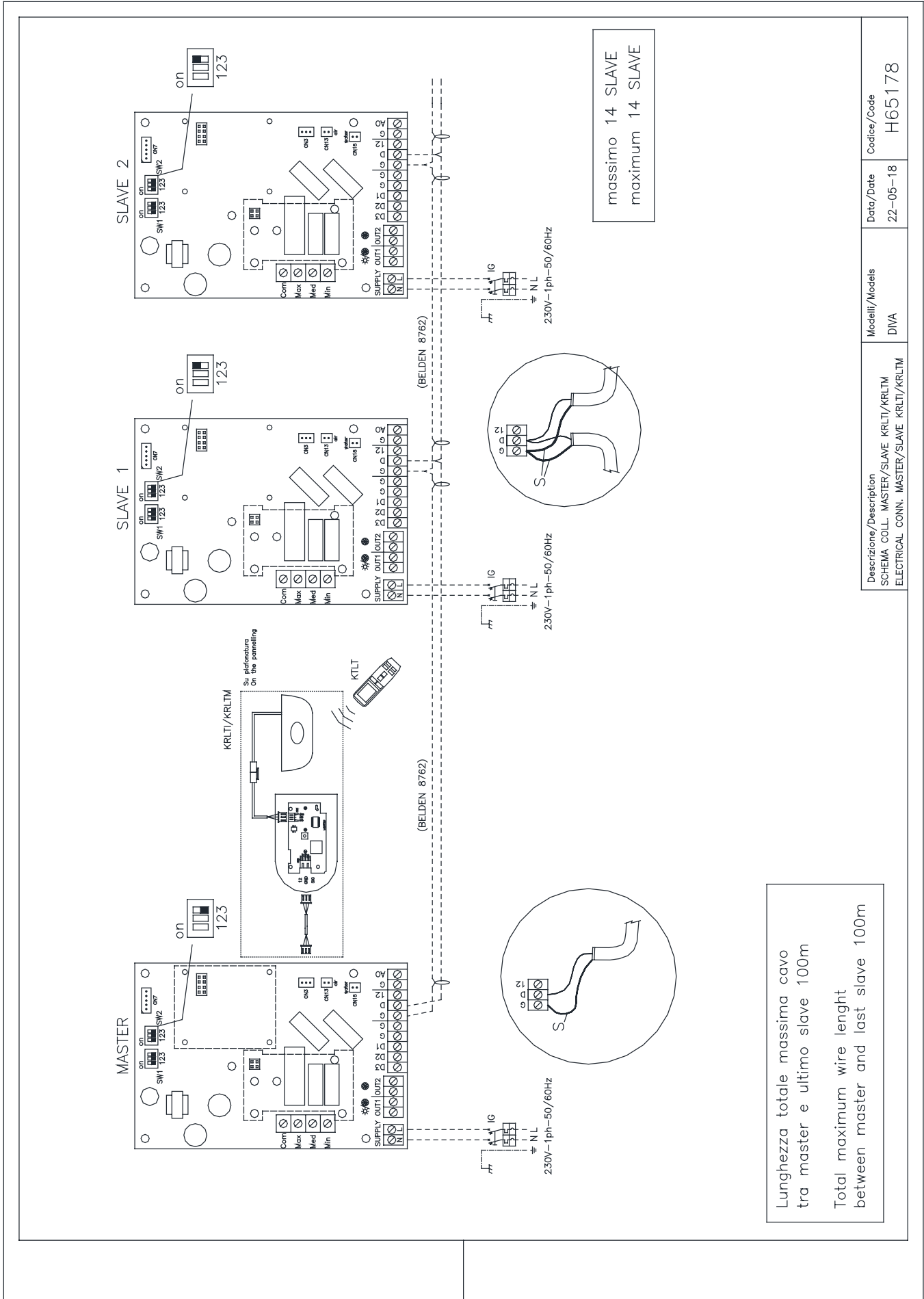

8. Connection diagrams Brio-I SLIM

CS.M/B, KCS.M/B

H2*	water temperature probe 10 k Ω
H4*	cold water temperature probe 10 k Ω - only (K)CS.M/B 4 pipes -
AIR	air temperature probe 10 k Ω
M1	fan motor DC inverter
Y1	water electrovalve (output at 230V/50Hz/1A voltage)
Y2	cold water solenoid valve (only (K) CS.M / B 4 pipes). Voltage output at 230V / 50Hz 1A
L-N	electrical supply connection 230V/50Hz

BO	boiler consent output (clean contact max 1A)
CH	chiller consent output (dry contact max 1A)
CP	Presence sensor input (if closed, the fan coil is put in standby)
HRS	water probe MVR (2k Ω) (only for (K)CS.M/B 2 pipes)
RS	MVR version wiring (only for (K) CS.M / B 2 pipes)
*	If after powering up the board detects the probe, the start-up takes place under normal conditions with minimum temperature functions of the acquau in heating (30 °C) and maximum in cooling mode (20 °C). The board also provides probe-free operation in which case the minimum and maximum thresholds are ignored.

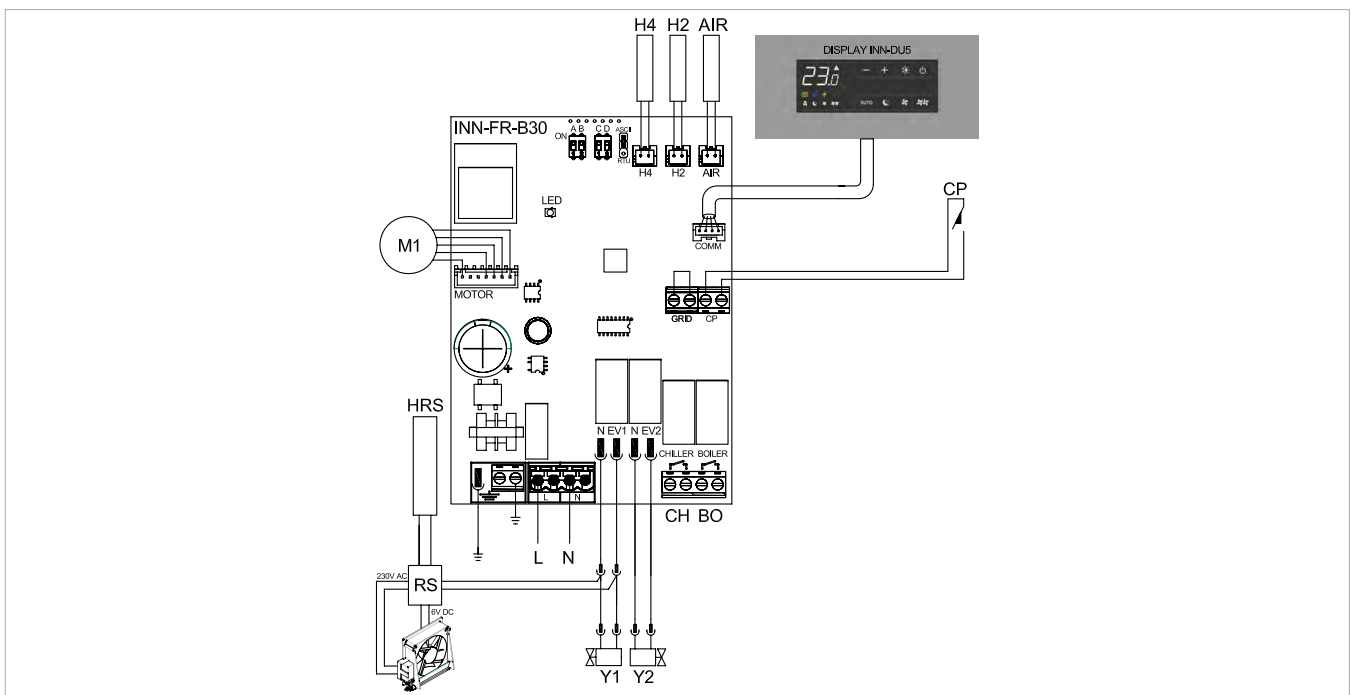

CS.M/P, KCS.M/P

-AB+	serial connection for KPST remote control (respect AB bias)
H2**	hot water temperature probe 10 kΩ
H4**	cold water temperature probe 10 kΩ - only (K)CS.M/P 4 pipes -
M1	fan motor DC inverter
Y1	hot water solenoid valve (voltage output at 230V / 50Hz 1A)
Y2	cold water solenoid valve ((K)CS.M/P 4 pipes). (voltage output at 230V / 50Hz 1A)
L-N	electrical supply connection 230V/50Hz
BO	boiler consent output (clean contact max 1A)
CH	chiller consent output (dry contact max 1A)

CP	not used in this version
HRS	water probe MVR (2kΩ) - only for (K)CS.M/P 2 pipes -
AIR	Optional air probe (*)
RS	MVR version wiring - only for (K)CS.M/P 2 pipes -
*	Connect as an alternative to the KPST wall control air probe
**	If after powering up the board detects the probe, the start-up takes place under normal conditions with minimum temperature functions of the acqau in heating (30 °C) and maximum in cooling mode (20 °C). The board also provides probe-free operation in which case the minimum and maximum thresholds are ignored.

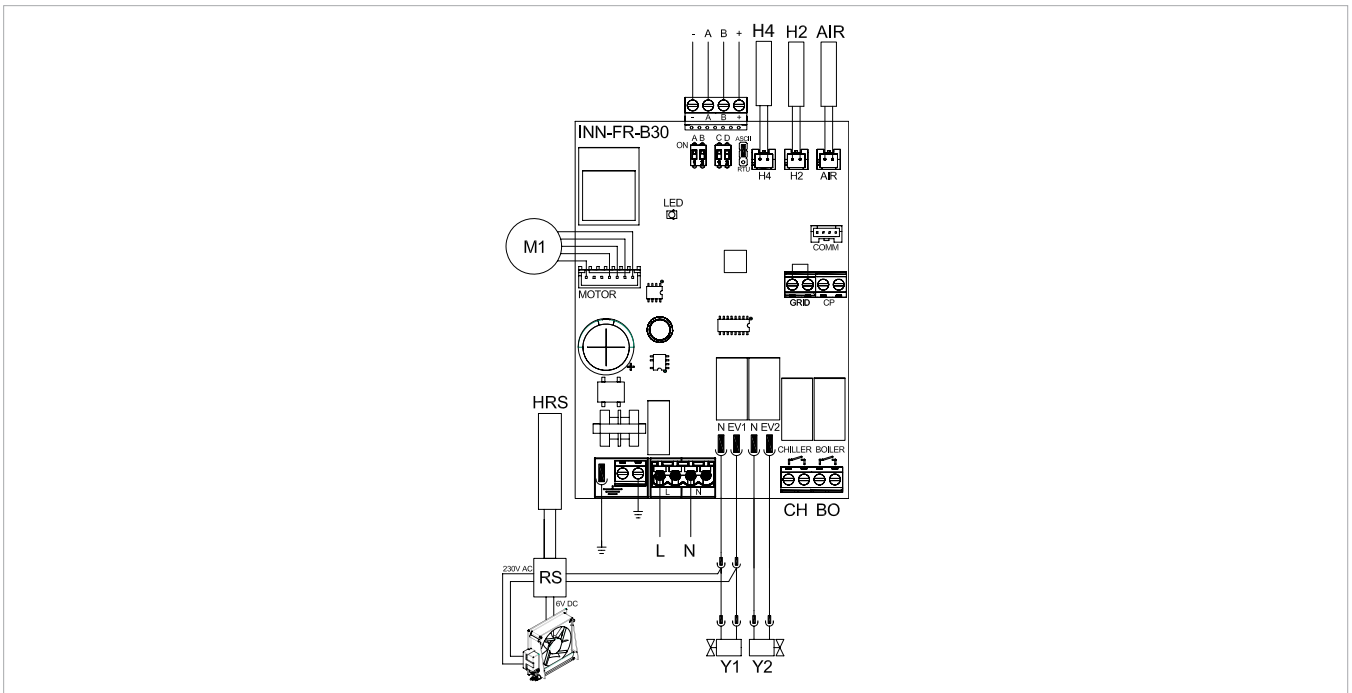

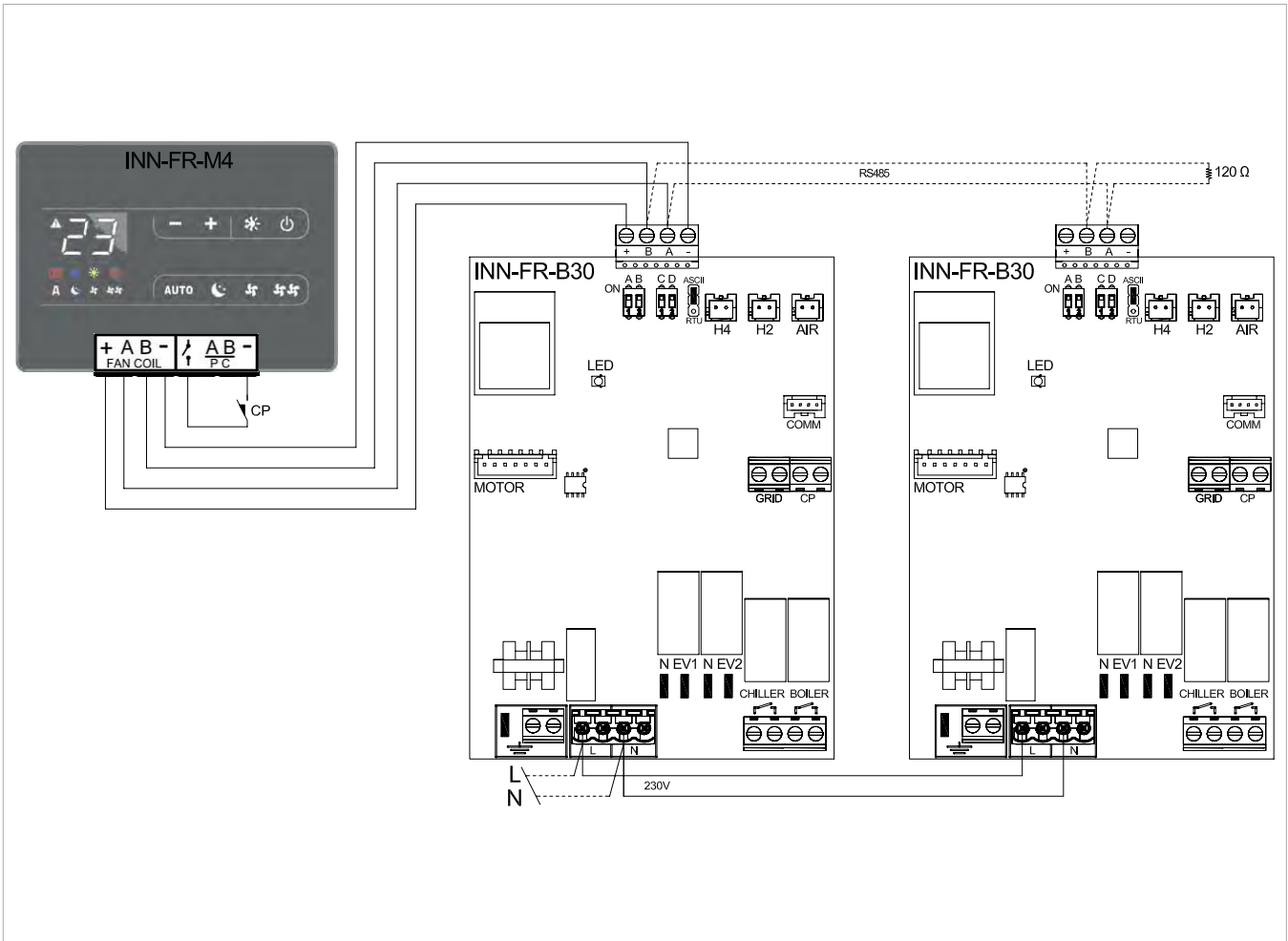

H2	water temperature probe 10 kΩ
M1	fan motor DC inverter
Y1	water electrovalve (output at 230V/50Hz/1A voltage)
L-N	electrical supply connection 230V/50Hz
RS	MVR version wiring

HRS	water probe MVR (2kΩ)
AIR	air temperature probe 10 kΩ
FF	output for servomotors mobile suction panel (voltage output at 230V / 50Hz 1A)

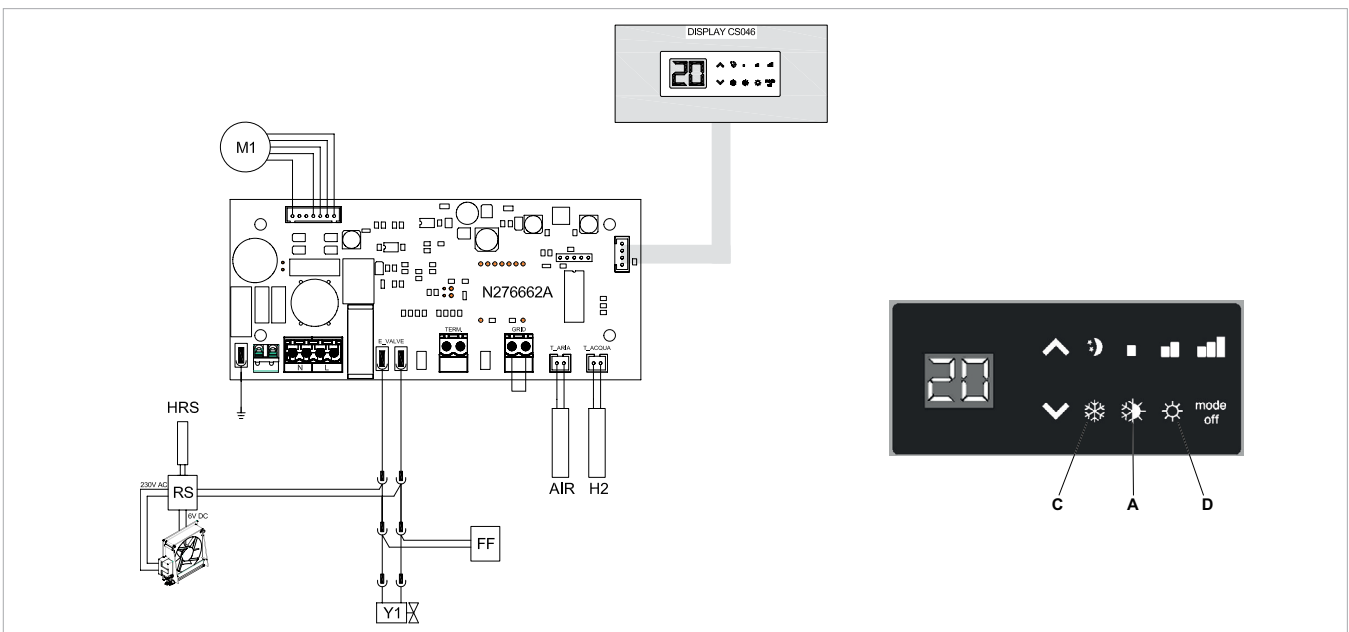

L-N	electrical supply 230V-50Hz
EV	electrovalve consent input
V1	maximum fan speed
V2	medium fan speed
V3	minimum fan speed
V4	supersilent speed
E	heating, cooling input selection See paragraph Water probe management
Y2	output for servomotors mobile suction panel (voltage output at 230V / 50Hz 1A)
Y1	water electrovalve (output at 230 V / 50 Hz / 1A voltage)

RS	MVR version wiring
HRS	water probe MVR (2 kΩ)
M1	fan motor DC inverter
Ta	3-speed room thermostat (to be bought, installed and connected by the installer)
CV	thermostat consent
SV	speed selector
H2*	water temperature probe (10 kΩ)
*	placed in the battery on board the machine. See paragraph Water probe management

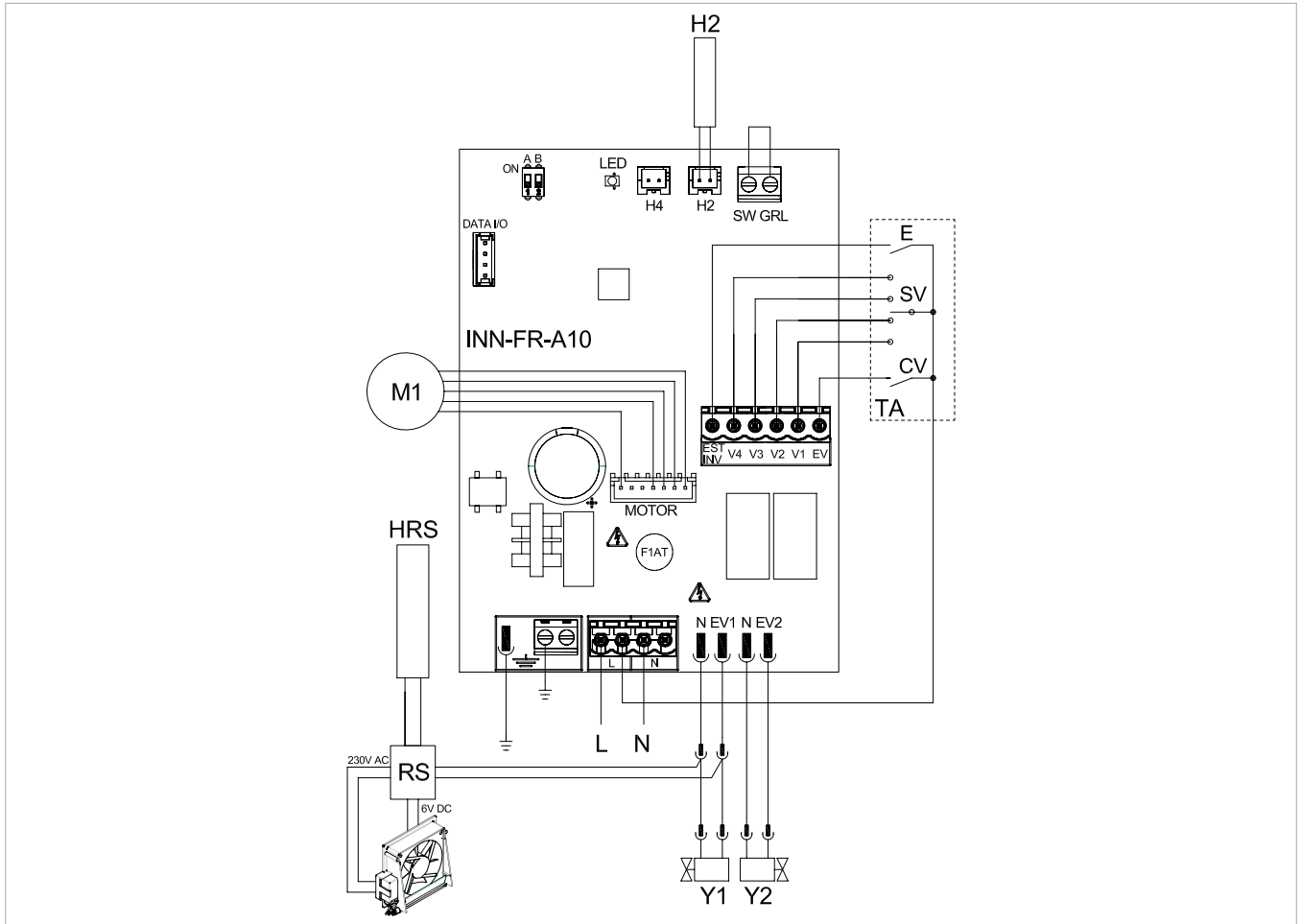

L-N	Electrical supply 230V-50 Hz
EV	Consent input
V1	Maximum fan speed (1.400 rpm)
V2	Medium fan speed (1.100 rpm)
V3	Minimum fan speed (680 rpm)
V4	Supersilent speed (400 rpm).
Y1	Hot water solenoid valve (voltage output at 230 V / 50 Hz 1A)
Y2	Cold water solenoid valve (voltage output at 230 V / 50 Hz 1A)

RS	MVR version wiring
HRS	water probe MVR (2 kΩ)
M1	Fan motor DC inverter
Y12	Water electrovalve (output at 230 V / 50 Hz / 1A voltage)
AIR	Air temperature probe (10K)
H2*	water temperature probe (10 kΩ)
H4*	cold water temperature probe (10 kΩ)
*	placed in the battery on board the machine. See paragraph Water probe management

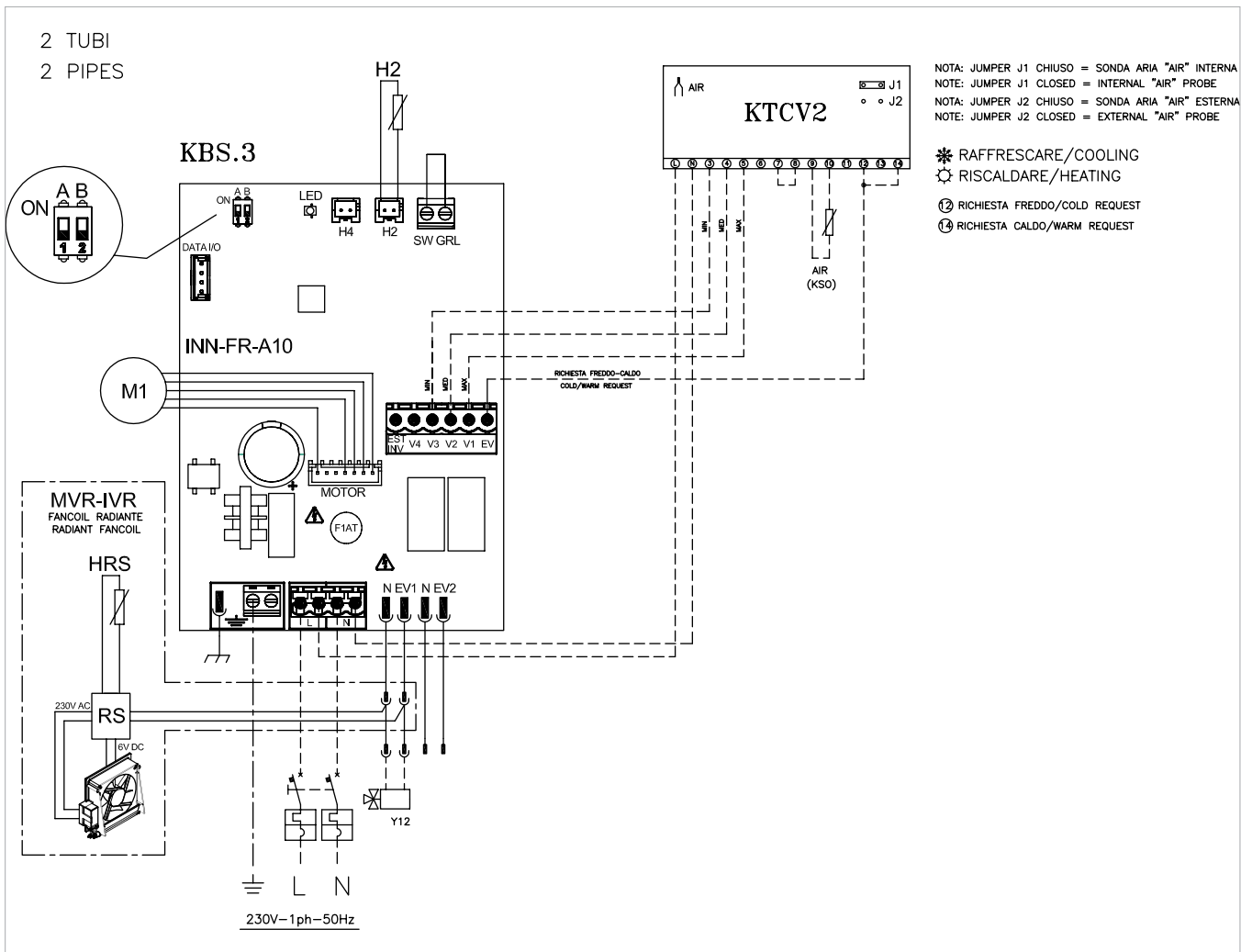

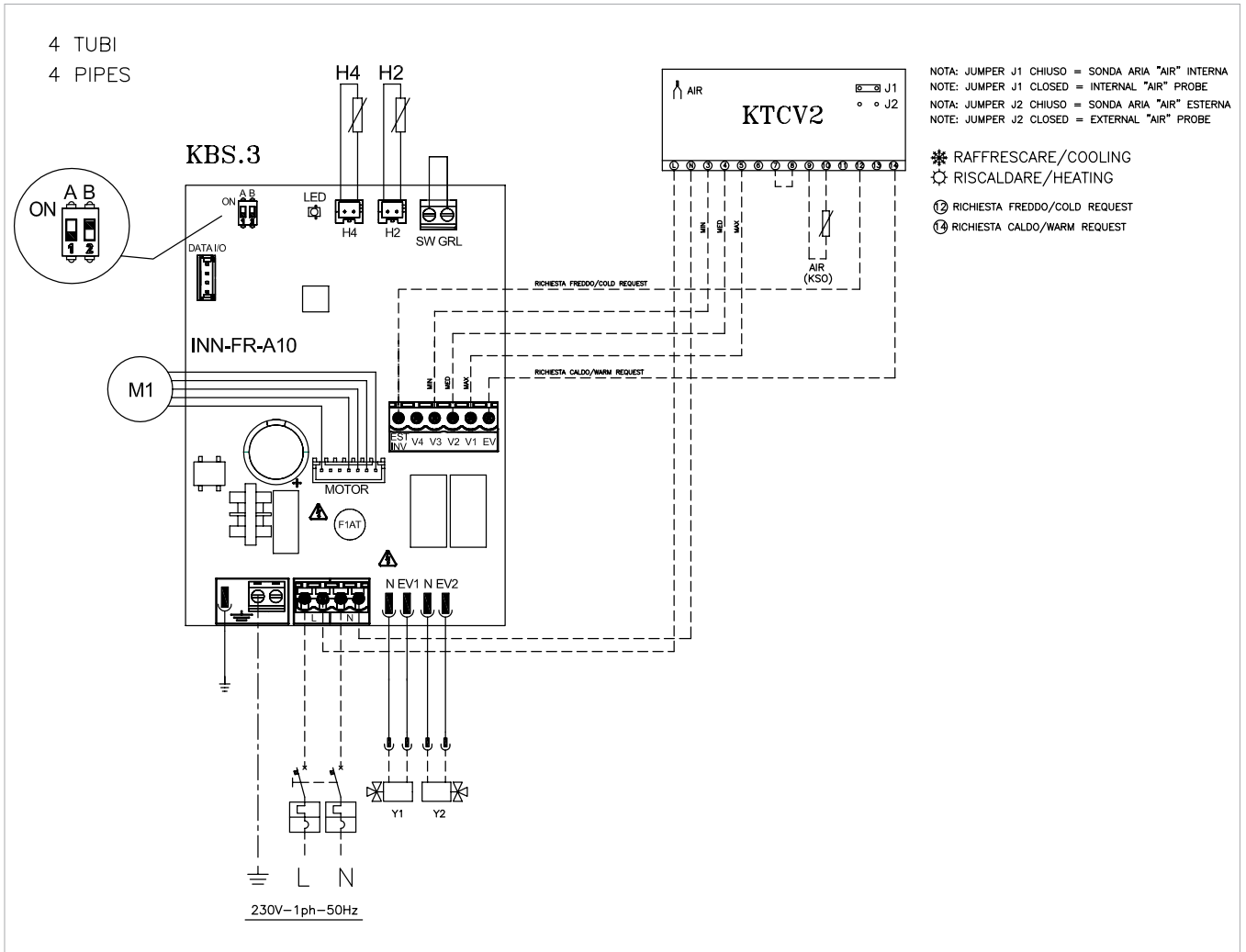

L-N	Electrical supply 230V-50 Hz
EV	Consent input
V1	Maximum fan speed (1.400 rpm)
V2	Medium fan speed (1.100 rpm)
V3	Minimum fan speed (680 rpm)
V4	Supersilent speed (400 rpm).
RS	MVR version wiring
HRS	water probe MVR (2 kΩ)

M1	Fan motor DC inverter
Y12	Water electrovalve (output at 230 V / 50 Hz / 1A voltage)
AIR	Air temperature probe (10K)
H2*	water temperature probe (10 kΩ)
ST2	Water temperature probe (season change)
*	placed in the battery on board the machine. See paragraph Water probe management

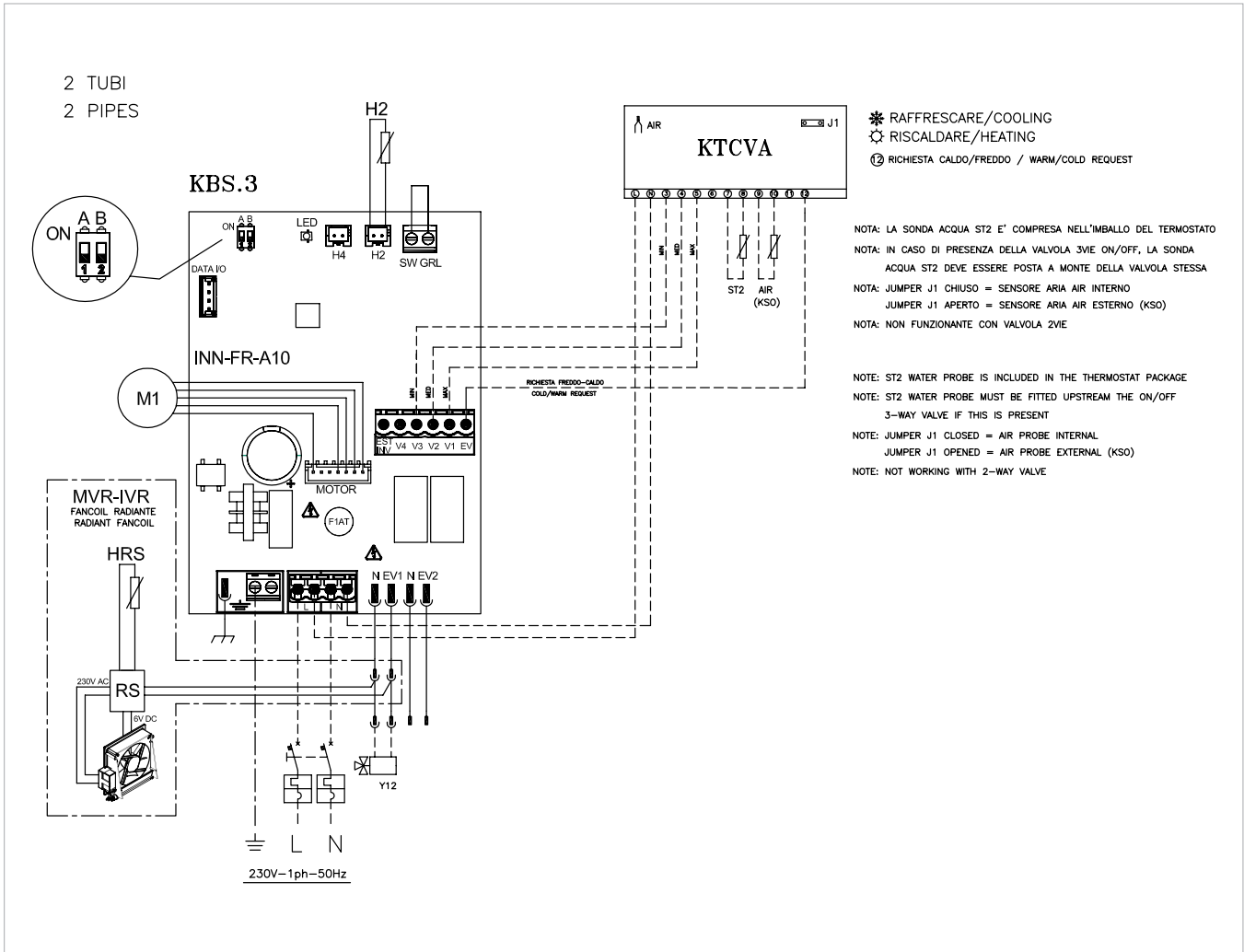

L-N	electrical supply 230V-50 Hz
10V	pilot input 0÷10 V
Y1	water electrovalve (output at 230V/50Hz/1A voltage)
Y2	output for servomotors mobile suction panel (voltage output at 230 V/ 50Hz 1A)

RS	RS version wiring
HRS	water probe RS (2 kΩ)
M1	fan motor DC inverter

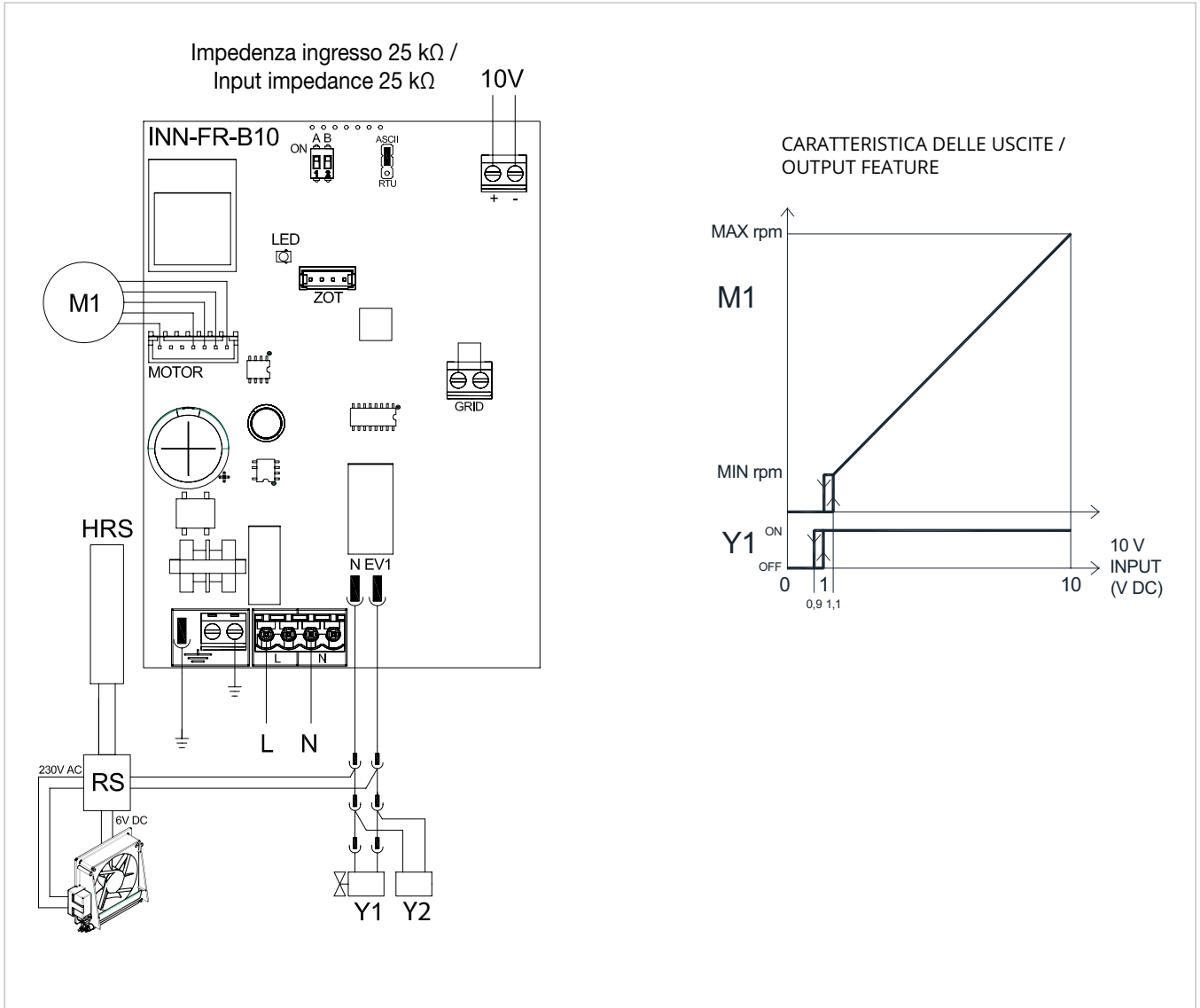

9. Yardy HP connections

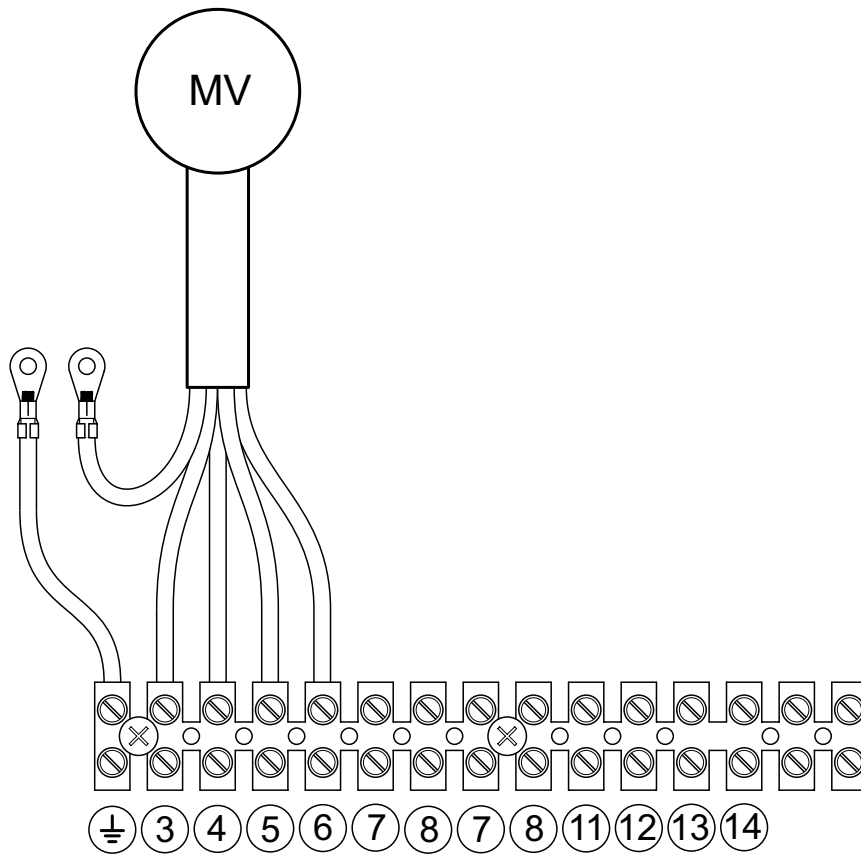

		Model			
		100	150	200-250	300
3	Minimum	Red	Orange	Red	Red
4	Medium	Orange	Black	Orange	Orange
5	Maximum	Black	Brown	Brown	Black
6	Common	Blu	Blu	Blu	Blu
⊕	Earth	Yellow/Green	Yellow/Green	Yellow/Green	Yellow/Green

Yardy HP	Basic unit
KCV2- KTCV2-KCTVA-KTCVR	Control panel
IG	General automatic switch
TM	Minimum thermostat
EV	Solenoid valve for summer / winter
EV1 / EV2	Summer solenoid valve / winter solenoid valve
ST1 / ST2	Air probe / water probe
L	Line
Water outlet	Neutral
---	Connections by installer
☉ / ❄	Heat / Cool

	Model			
	100	150	200-250	300
Min	Red	Orange	Red	Red
Med	Orange	Black	Orange	Orange
Max	Black	Brown	Brown	Black
Com	Blu	Blu	Blu	Blu

Yardy HP + KCV2 (2 pipes)

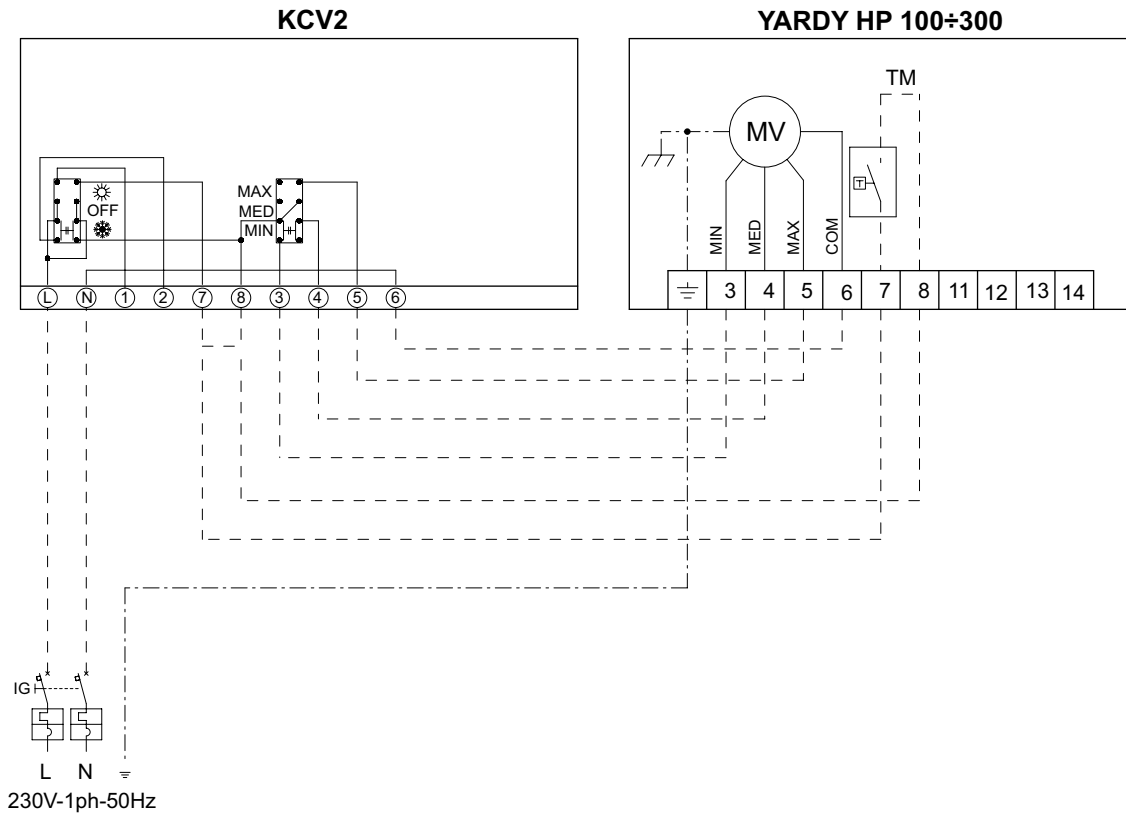

TM not supplied

Yardy HP + KTCV2 (2 pipes)

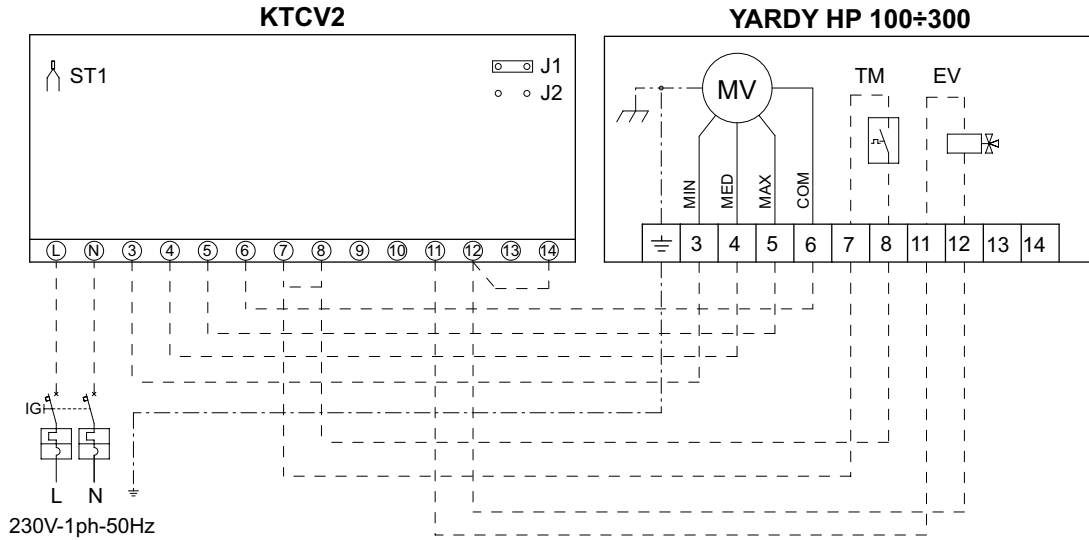

Yardy HP + KTCV2 (4 pipes)

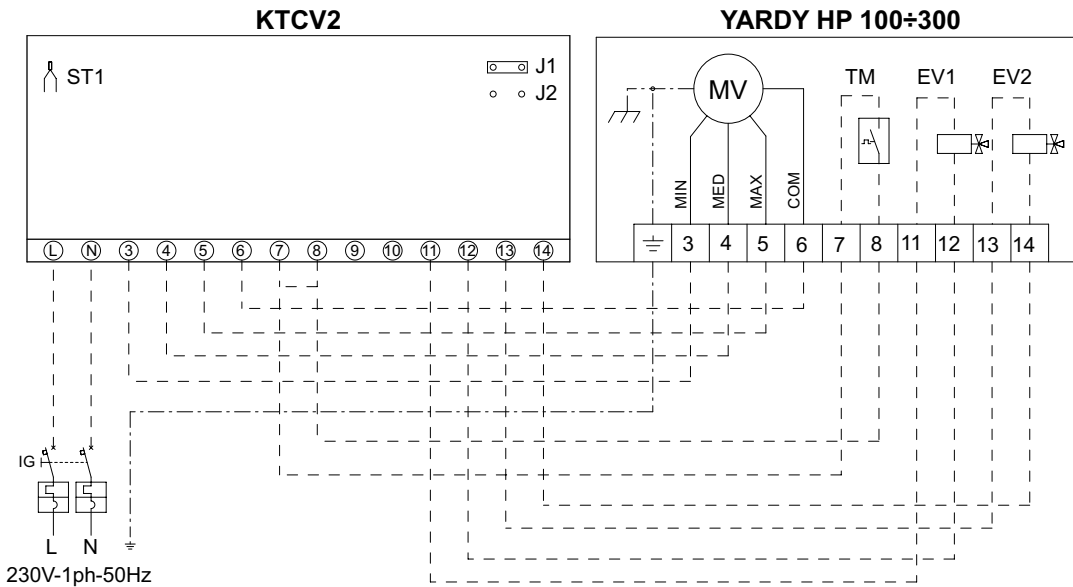

TM not supplied

Jumper J1 closed = Internal Air Probe ST1

Jumper J2 Closed = Air probe ST1 External

Yardy HP + KTCVA (2 pipes)

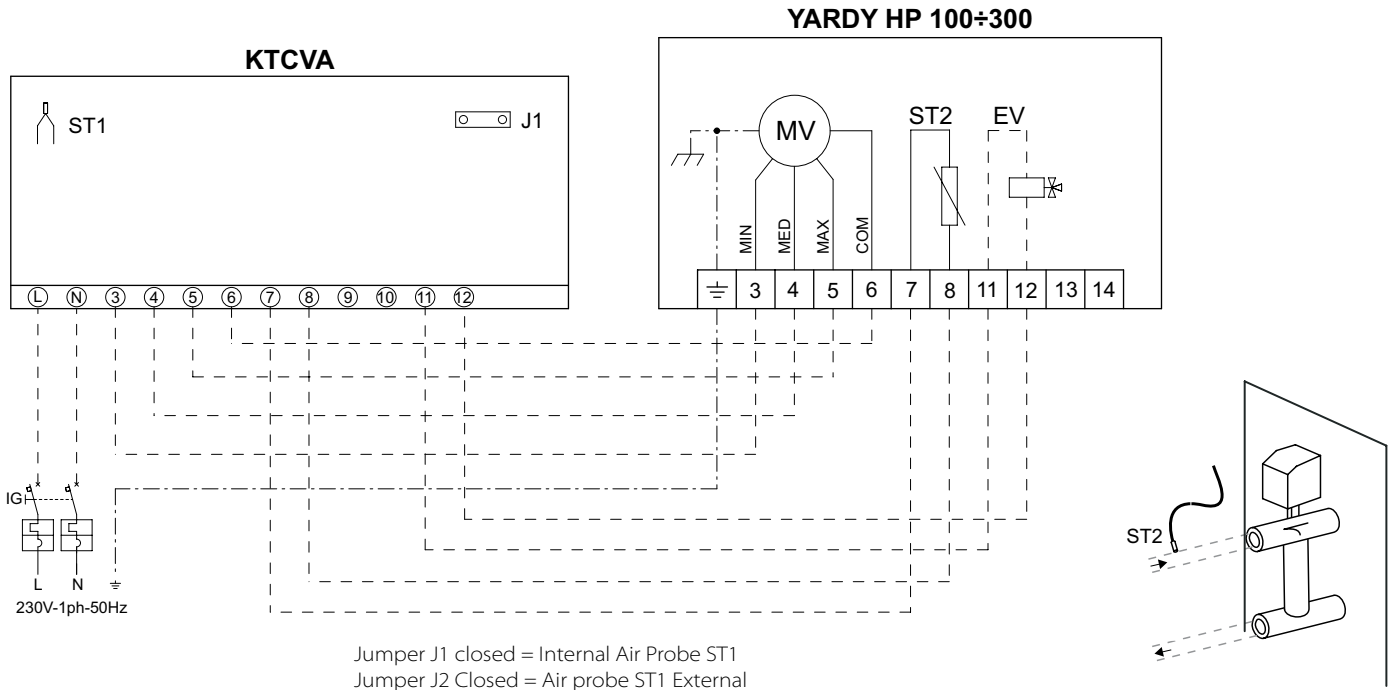

Jumper J1 closed = Internal Air Probe ST1
 Jumper J2 Closed = Air probe ST1 External

The ST2 water probe is included in the thermostat packaging.
 If the 3-way ON / OFF valve is present, the water probe ST2 must be placed upstream of the valve itself.

NOTE: the control does not work with a 2-way valve

Yardy HP + KTCVR (2 pipes)

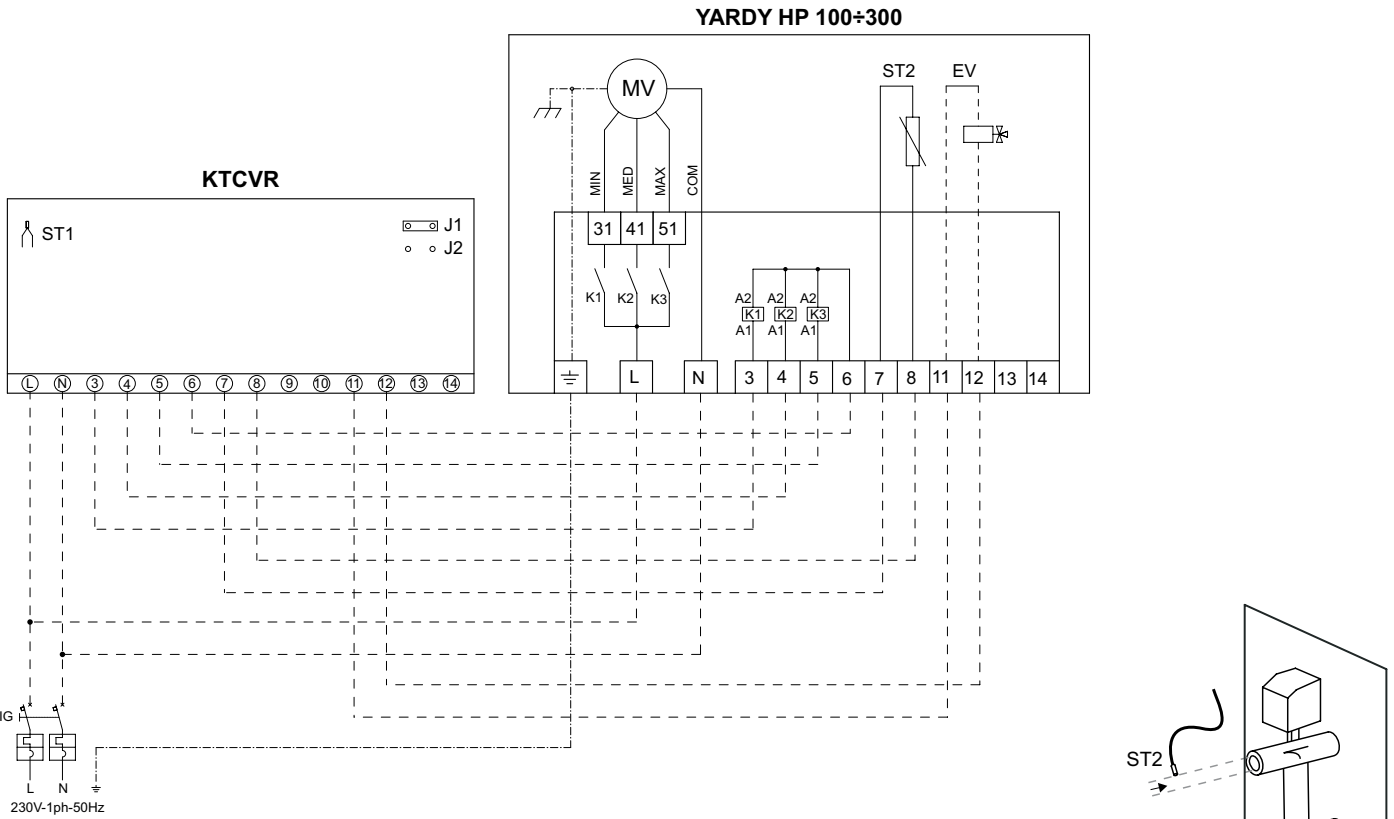

Jumper J1 closed = Internal Air Probe ST1
 Jumper J1 open = External Air Probe ST1
 Jumper J2 Closed = 4 pipes
 Jumper J2 open = 2 pipes (2 pipes + RE)

The ST2 water probe is included in the thermostat packaging.
 2-pipe system (2 pipes + resistor) Jumper J2 open and water probe ST2 upstream of the valve (if present).

NOTE: the control does not work with a 2-way valve

Yardy HP + KTCVR (4 pipes)

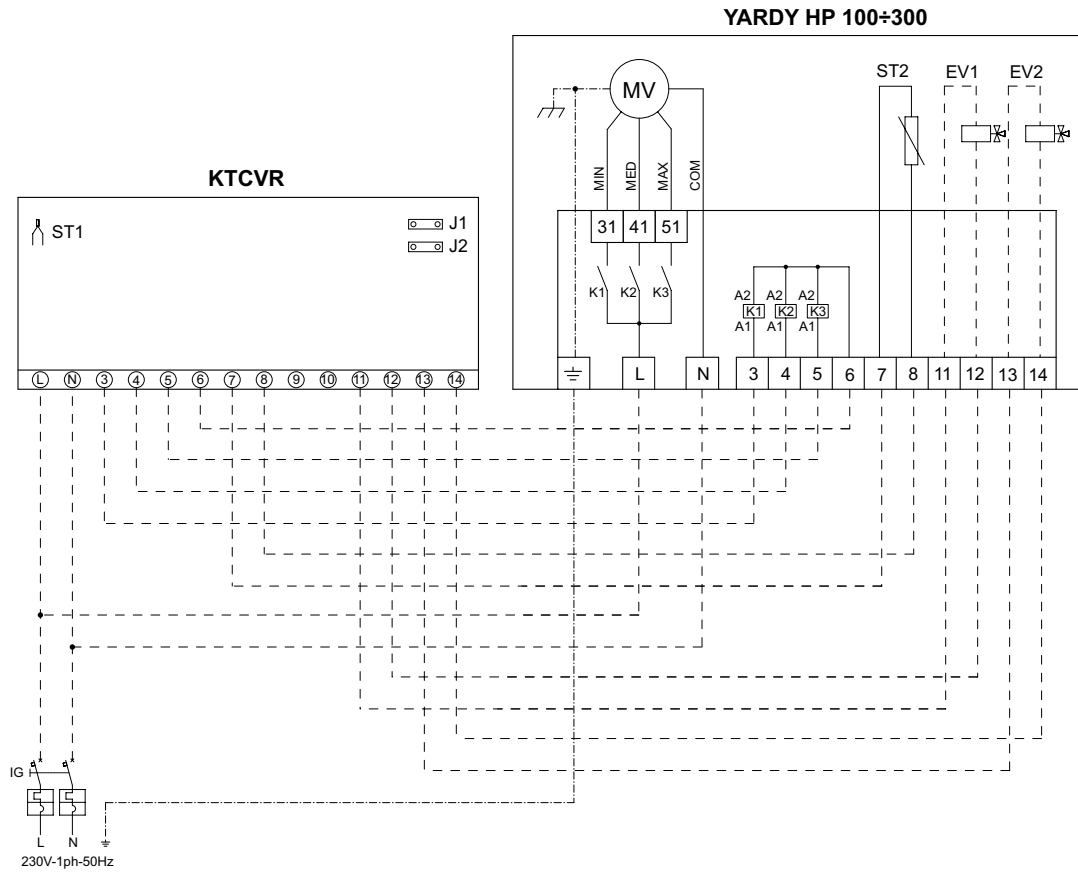

- Jumper J1 closed = Internal Air Probe ST1
- Jumper J1 open = External Air Probe ST1
- Jumper J2 Closed = 4 pipes
- Jumper J2 open = 2 pipes (2 pipes + RE)

The ST2 probe is included in the thermostat packaging.
4-pipe system, Jumper J2 closed and water probe ST2 positioned on the hot battery (with or without valve).

NOTE: the control does not work with a 2-way valve

Electrical connection of advanced controls LIT-TOUCH – Yardy HP

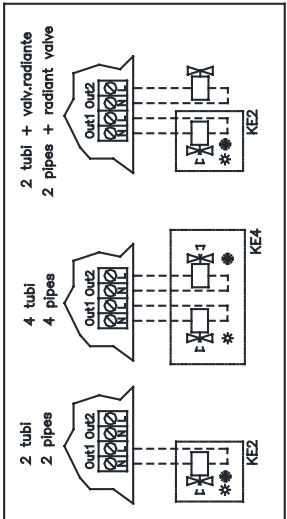
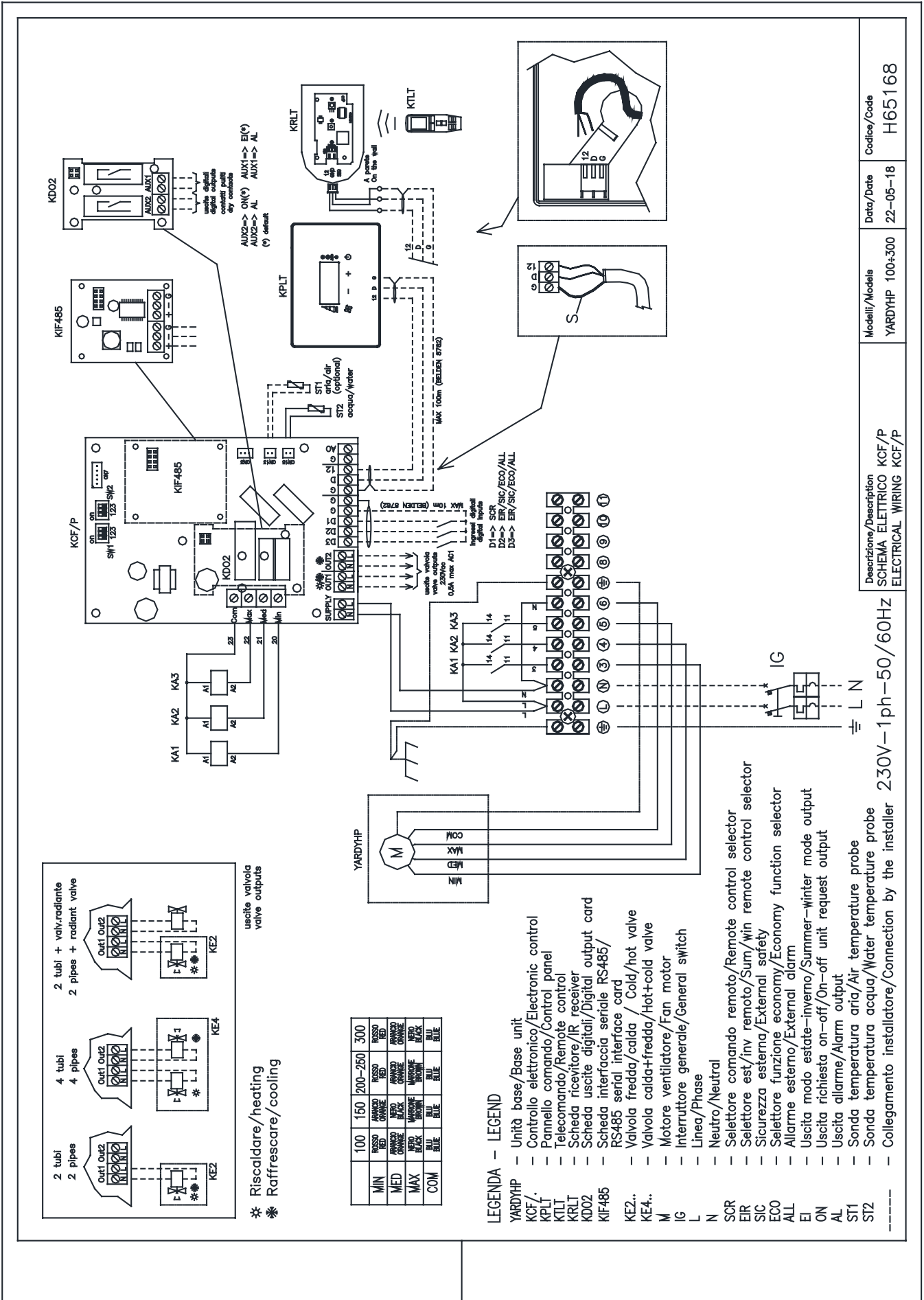

* Riscaldare/heating
* Raffrescare/cooling

	100	150	200-250	300
MIN	RUSO	AVANZO	RUSO	RUSO
	NERO	GRANDE	NERO	NERO
MED	RUSO	GRANDE	NERO	NERO
	NERO	GRANDE	NERO	NERO
MAX	NERO	GRANDE	NERO	NERO
	NERO	GRANDE	NERO	NERO
COM	NERO	GRANDE	NERO	NERO
	NERO	GRANDE	NERO	NERO

LEGENDA -- LEGEND

- YARDYHP - Unità base/Base unit
- KCF/. - Controllo elettronico/Electronic control
- KPL/. - Pannello comando/Control panel
- KTLT - Telecomando/Remote control
- KRLT - Scheda ricevitore/IR receiver
- KDO2 - Scheda uscite digitali/Digital output card
- KIF485 - Scheda interfaccia seriale RS485/RS485 serial interface card
- KE2.. - Valvola fredda/calda / Cold/hot valve
- KE4.. - Valvola calda+fredda/Hot+cold valve
- M - Motore ventilatore/Fan motor
- IG - Interruttore generale/General switch
- L - Linea/Phase
- N - Neutro/Neutral
- SCR - Selettore comando remoto/Remote control selector
- EIR - Selettore est./inv remoto/Sum/win remote control selector
- SIC - Sicurezza esterna/External safety
- ECC - Selettore funzione economy/Economy function selector
- ALL - Allarme esterno/External alarm
- EI - Uscita modo estate-inverno/Summer-winter mode output
- ON - Uscita richiesta on-off/On-off unit request output
- AL - Uscita allarme/Alarm output
- ST1 - Sonda temperatura aria/Air temperature probe
- ST2 - Sonda temperatura acqua/Water temperature probe
- - Collegamento installatore/Connection by the installer

Descrizione/Description	Modelli/Models	Data/Date	Codice/Code
SCHEMA ELETTRICO KCF/P ELECTRICAL WIRING KCF/P	YARDYHP 100+300	22-05-18	H65168

10. Connection INT and KADC

Connection INT

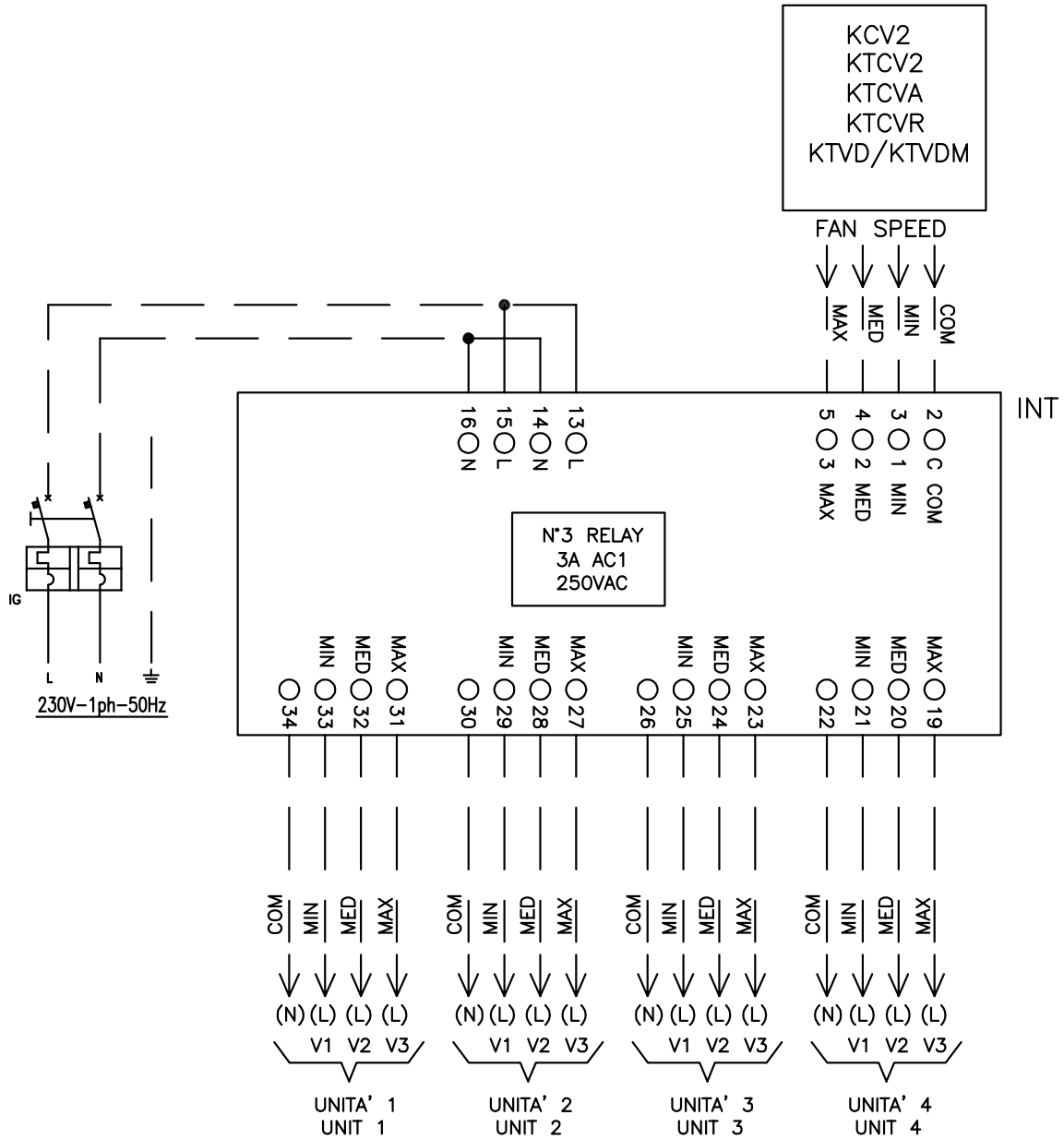

LEGENDA/LEGEND

- IG - Interruttore automatico generale/General automatic switch
- L - Fase/Phase
- N - Neutro/Neutral
- - Collegamento a cura dell'installatore/Connection by installer

Connection KADC

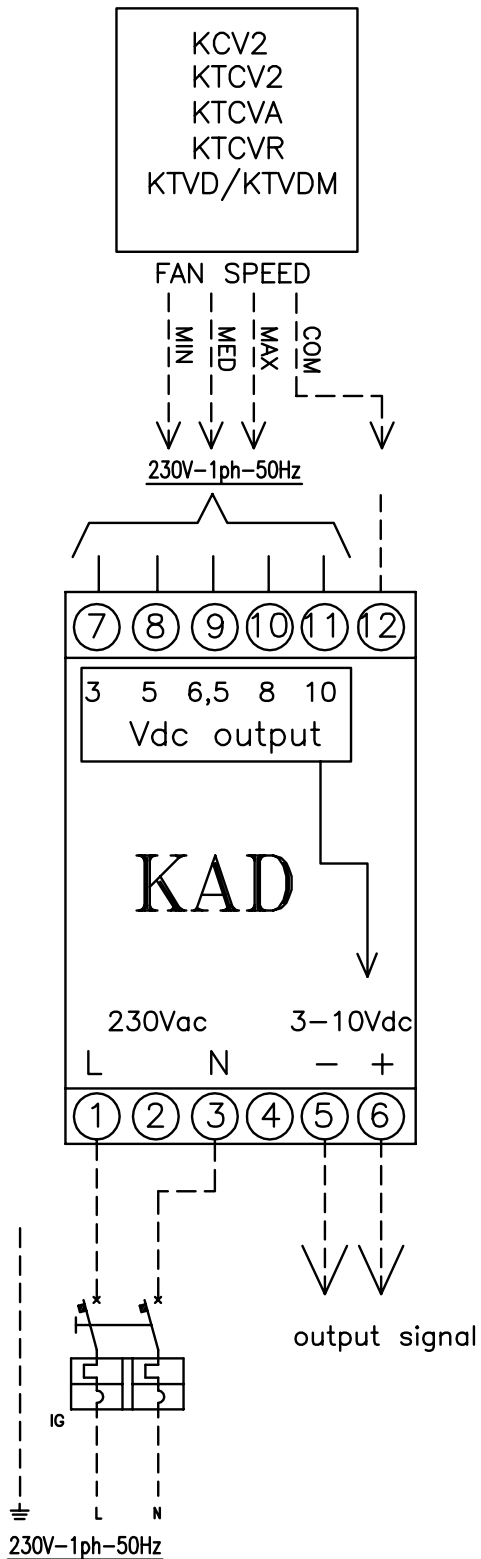

LEGENDA/LEGEND

- IG - Interruttore automatico generale/General automatic switch
- L - Fase/Phase
- N - Neutro/Neutral
- - Collegamento a cura dell'installatore/Connection by installer

10. SYS-TO System Touch Manager & Web App

System management solutions for small and medium tertiary, trade and services applications.
Touch interface with Web APP for remote control and monitoring.

SYS-TO System Touch Manager & Web APP

The entire system
at your fingertips

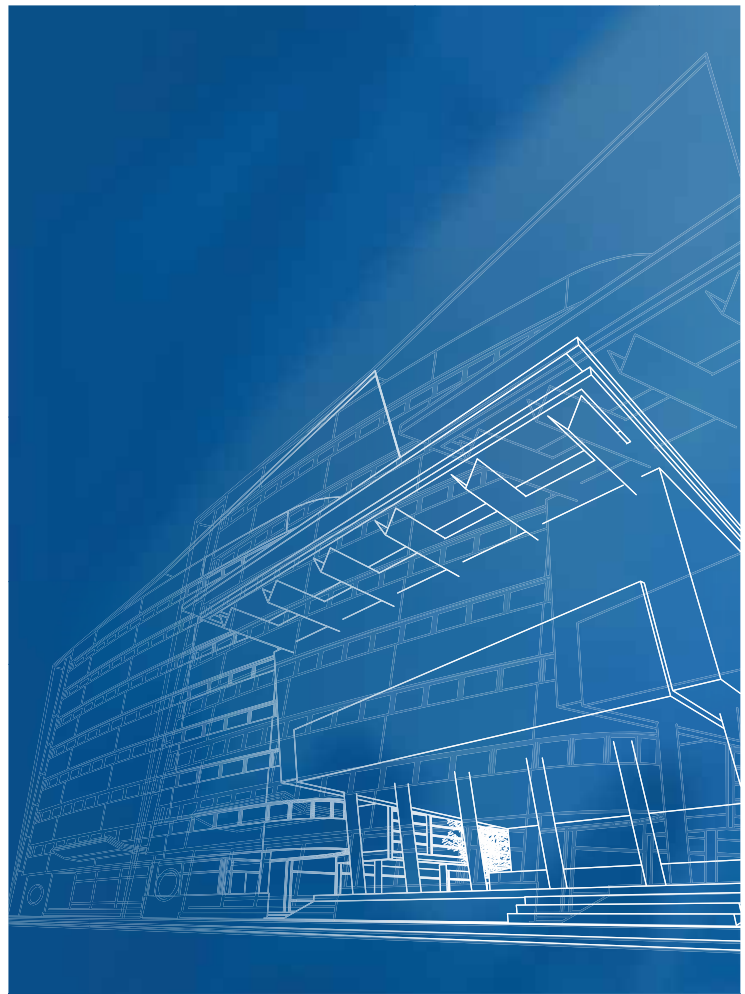

System Touch Manager offers a simple and effective interface to control and program the climate of the individual rooms of a building, manage the main system components and the environment terminals from a single point, as required in the tertiary, trade and services installations, such as offices, hotels, shops and multi-purpose centres.

The system offers a series of energy saving functions for the management of generators, the production of domestic hot water, the distribution network and the terminal units such as, management with time bands that allows 10 summer/winter bands to be programmed at 2 temperature levels.

It is also possible to manage via the local network and remote monitoring via the web.

The SYS-TO

solution is an integrated management system that manages the system's main components via the electronic System Manager regulator.

User interaction with the management program is very easy; it can be managed via a simple and user-friendly touch screen display or interface.

SYS-TO enables centralised management of up to maximum 64 areas made up of fan coils with relative temperature control. It is also possible to manage a cooling unit-chiller, a RHOSS multi-purpose heat pump with integrated boiler- and up to 5 VMC units, heat recovery units or air handling units.





Functions

System manager, which is available in a small or medium version, enables you to:

- control the temperature detected in the various areas
- set the area set-point and limit the change
- limit user interaction with the area control
- control the fan coil with time bands (stop or start with two comfort levels)
- adjust the water temperature sent to the radiant panels in heating mode, with a mixing valve and climate compensation
- adjust the water temperature in the system side tank with 2 levels, comfort and economy, with climate compensation
- adjust the water temperature in the DHW tank
- manage the DHW side diverter valve
- communicate the set-point to the primary generator
- select the summer/winter operating mode manually, by date, outdoor temperature or digital input
- select the most convenient heat generator between the heat pump and boiler
- manage an integrative heat source - electrical resistance - or auxiliary - boiler, system side or DHW side
- manage the DHW recirculation pump and anti-legionella sanitisation
- manage the area pumps, based on the start status or effective call in the single areas
- start the VMC/primary air units
- send an email alarm in real time



System management solutions for small and medium tertiary, trade and services applications.

Touch interface with Web APP for remote control and monitoring.

SYS-TO System Touch Manager & Web APP

The entire system
at your fingertips

System management

SYS-TO allows for integrated management of the following components in 2-pipe systems and 2-pipe systems with domestic hot water (DHW) production:

Generators

- Rhoss heat pump/chiller or multi-purpose system
- Inertial buffer tank temperature probes on the system side
- Technical tank temperature probes for DHW production
- Integrative heat source - electrical resistance - or auxiliary - boiler.
- Diverter valve for DHW
- Outdoor air temperature probe for climatic compensation or seasonal switching

Distribution network

- Area circulation pumps, for primary or primary/secondary circuit, direct or mixed, at low temperature (up to 5)

System terminals

- Control up to 64 fan coils or terminals with on-board regulation in serial connection, possibility of activating other devices in parallel with the fan coil (radiant panels in heating mode or radiators)
- Fresh air consent for VMC, Heat recovery units and Air handling units (up to 5)

SYS-TO in 4-pipe systems allows system terminals and area pumps to be managed.



Compatible units

Fan coils: Idrowall (with dedicated serial cable), Brio-I Slim with advanced SLIM Touch regulation, Yardy and Diva via advanced LIT-Touch regulation, via bus.

Rhoss chillers, heat pumps and multi-purpose units, via bus.

VMC unit, heat recovery units with KRCA1 regulator, ADV Next Air and CTA ADVR air handling units via bus or digital input.

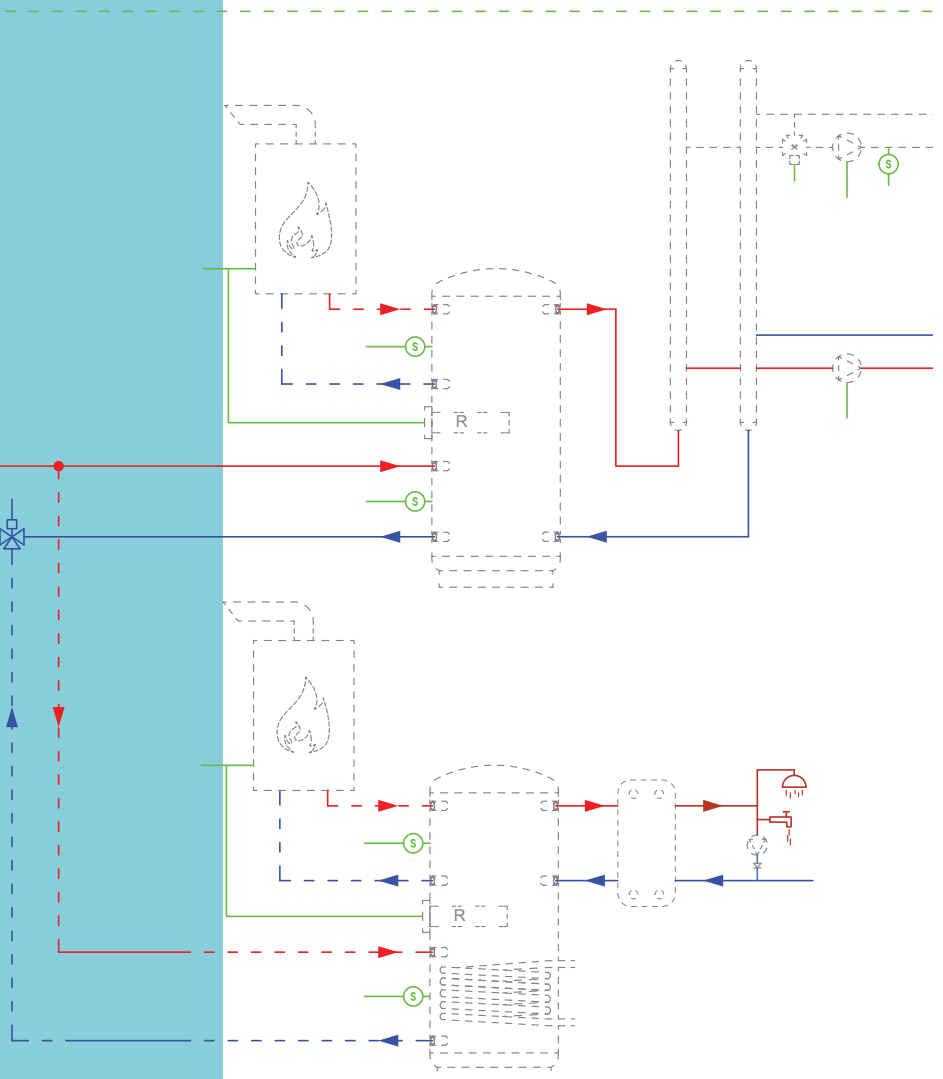

User interfaces and remote control via WEB

SYS-TO consists of a regulator (System Manager) to control room terminals (connected in serial mode) and to manage components in the field (through digital inputs and outputs) and from a user interface (HMI) available in various types.

The simplest interface consists of a semi-graphical LCD integrated in the regulator, to which a remote keypad with a backlit semi-graphical LCD display can be added.

The top of the range is the Touch Panel consisting of a resistive touch screen with a 7" TFT 16:9 -64 K colour recessed display installed on a support or wall-mounted, with a clean and innovative design and a lively and intuitive interface, complete with an Ethernet interface and USB port.

The Touch Panel is available with the Web APP option for remote control and monitoring through any Web browser with HTML5 support.

Solution with:	Integrated semi-graphical interface	Remotable semi-graphical interface	Touch colour interface	Touch colour interface and Web APP
Web APP				
HMI				
System Manager				

Serial network with simplified routing

An RS485 ModBus RTU serial interface is required on each connected device for connection via bus. Configuring serial addresses is extremely easy; it does not require additional devices but can be made directly from the control keypad of each fan coil.

Master/slave management

It is possible to connect multiple slave units with the same ambient set-point for each Master fan coil equipped with a control or receiver.

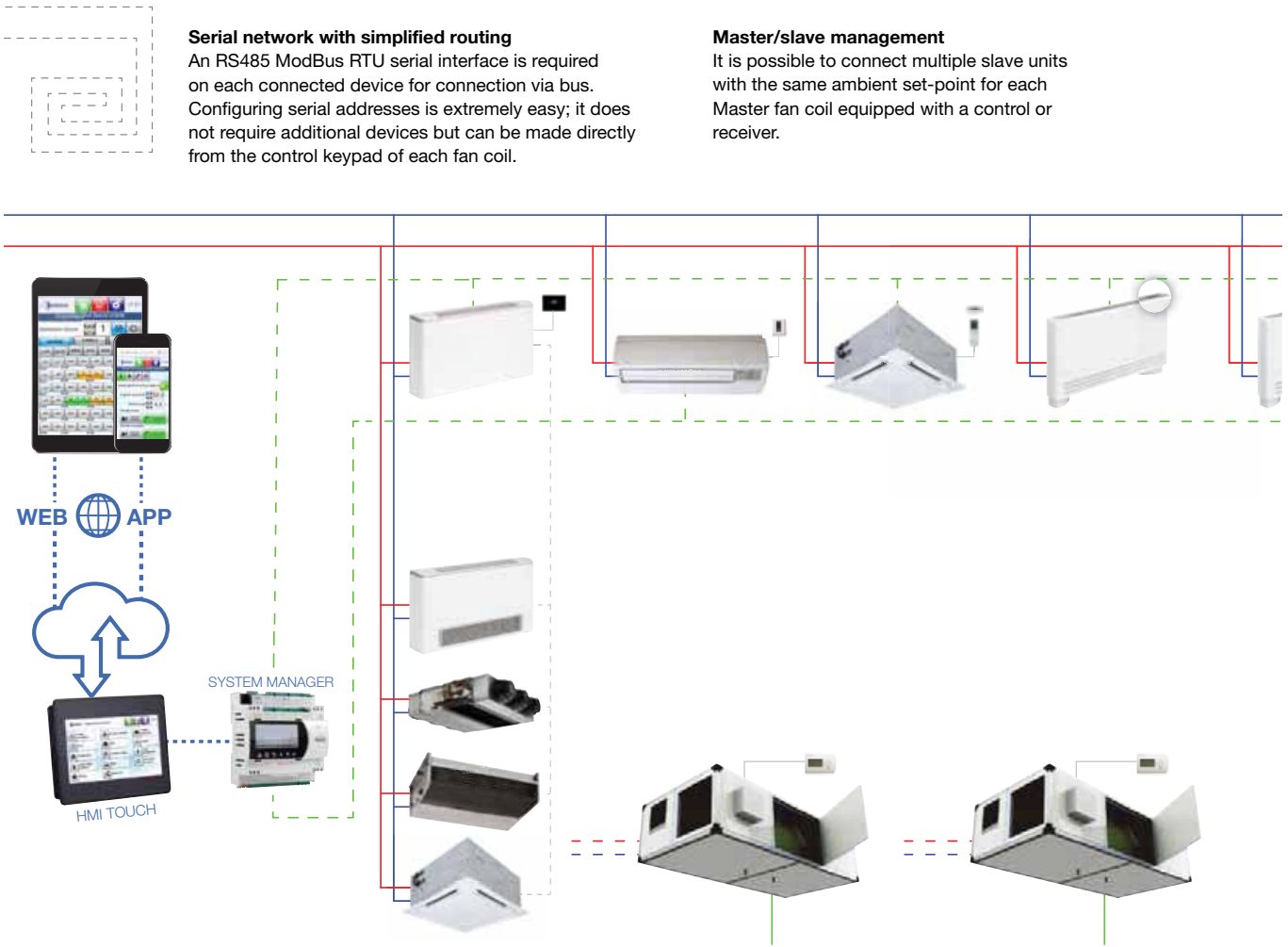





RHOSS S.P.A.

Via Oltre Ferrovia, 32 - 33033 Codroipo (UD) - Italy
tel. +39 0432 911611 - fax +39 0432 911600
rhoss@rhoss.it - www.rhoss.it - www.rhoss.com

IR GROUP SARL

19, chemin de la Plaine - 69390 Vourles - France
tél. +33 (0)4 72 31 86 31 - fax +33 (0)4 72 31 86 30
exportsales@rhoss.it

RHOSS Deutschland GmbH

Hölzlestraße 23, D-72336 Balingen, OT Engstlatt - Germany
tel. +49 (0)7433 260270 - fax +49 (0)7433 2602720
info@rhoss.de - www.rhoss.de

RHOSS GULF JLT

Suite No: 3004, Platinum Tower
Jumeirah Lakes Towers, Dubai - UAE
ph. +971 4 44 12 154 - fax +971 4 44 10 581
e-mail: info@rhoss.gulf.com

Uffici commerciali Italia:

Codroipo (UD)
33033 Via Oltre Ferrovia, 32
tel. +39 0432 911611 - fax +39 0432 911600

Nova Milanese (MB)

20834 Via Venezia, 2 - p. 2
tel. +39 039 6898394 - fax +39 039 6898395

