



- 机床设备上切削液的输送  
Cutting fluid transfer for machine equipment
- 电火花  
Electric spark
- 加工中心  
Machining centre
- 铁屑输送机  
Slag transportation

## 卧式多级离心泵 (LDPB4 系列)

Horizontal Multistage Centrifugal Pump (LDPB4 Series)



外形图 (Outline Drawing)

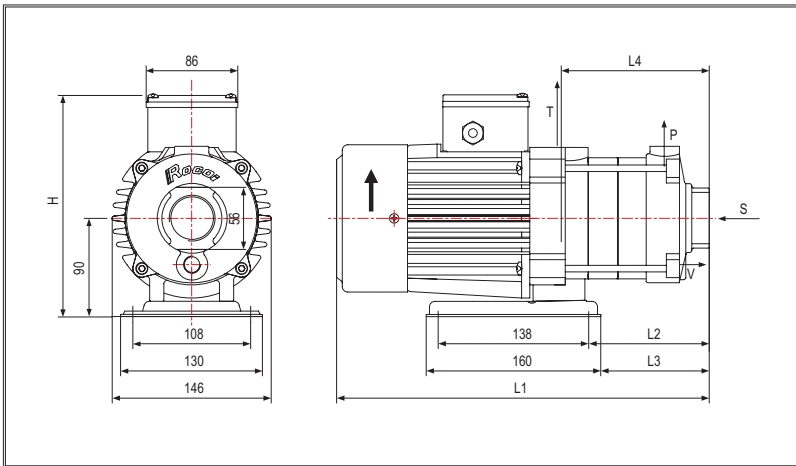

性能曲线图 (Performance Curves)

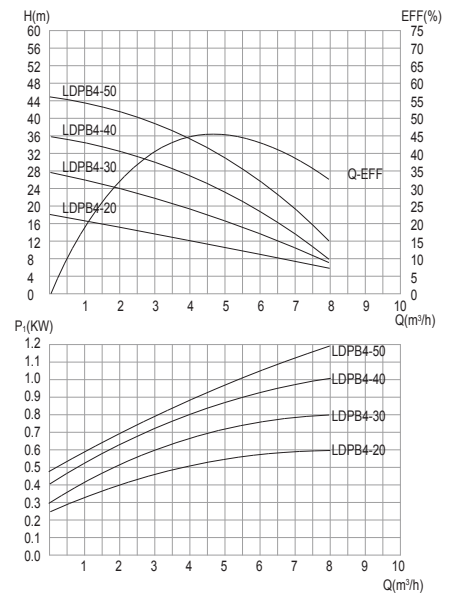

技术参数 (Technical parameters)

水泵型号 Model	1×220-240/50HZ		3×380-420/50HZ		L1 (mm)	L2 (mm)	L3 (mm)	L4 (mm)	P、V	S、T	H(mm)		净重 (Kg)
	功率(W)	电流(A)	功率(W)	电流(A)							单相	三相	
LDPB4-20	500	2.3	550	1.1	314	83	72	108	Rp <sup>3</sup> / <sub>8</sub>	Rp1 <sup>1</sup> / <sub>4</sub> Rp1	212	205	10.0
LDPB4-30	800	3.6	750	1.2	342	110	99	135	Rp <sup>3</sup> / <sub>8</sub>	Rp1 <sup>1</sup> / <sub>4</sub> Rp1	212	205	11.0
LDPB4-40	1100	4.6	920	1.5	395	137	126	163	Rp <sup>3</sup> / <sub>8</sub>	Rp1 <sup>1</sup> / <sub>4</sub> Rp1	212	205	12.5
LDPB4-50			1200	2.3	438	165	153	190	Rp <sup>3</sup> / <sub>8</sub>	Rp1 <sup>1</sup> / <sub>4</sub> Rp1	212	205	14.5