

General information

Hybalans+ Supp/Extr air valve Disc

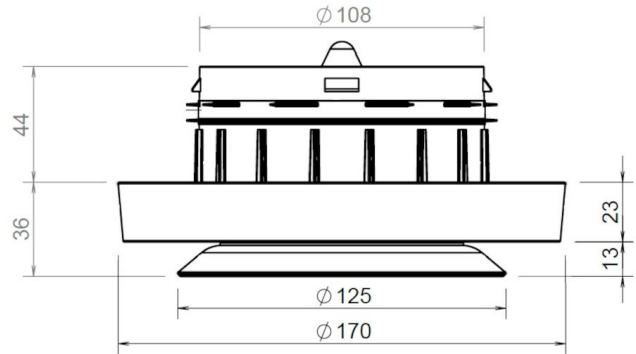

Specifications

Article number	400470418
Product category	Air valves
Material	PP
Colour	RAL-9016
Weight (kg)	0,22

Dimensions

Dimensions (l x w x h mm)	170 x 170 x 80
Connection diameter ridged (mm)	117-125

Application Insights

Application	Air
Supply / Extract	Supply/Extract
Temperature range (°C)	-25 / +80

Technical Specifications

Maximum air flow (m ³ /h)	50
ζ extract	3,10
ζ supply	1,40
Air tightness class (ATC)	-
R-value (m ² K/W)	0
Fire rating EN 13501-1	F
Other specifications	-

Disc valve with valve connection 125 92 90° (400480616)

Pressure loss

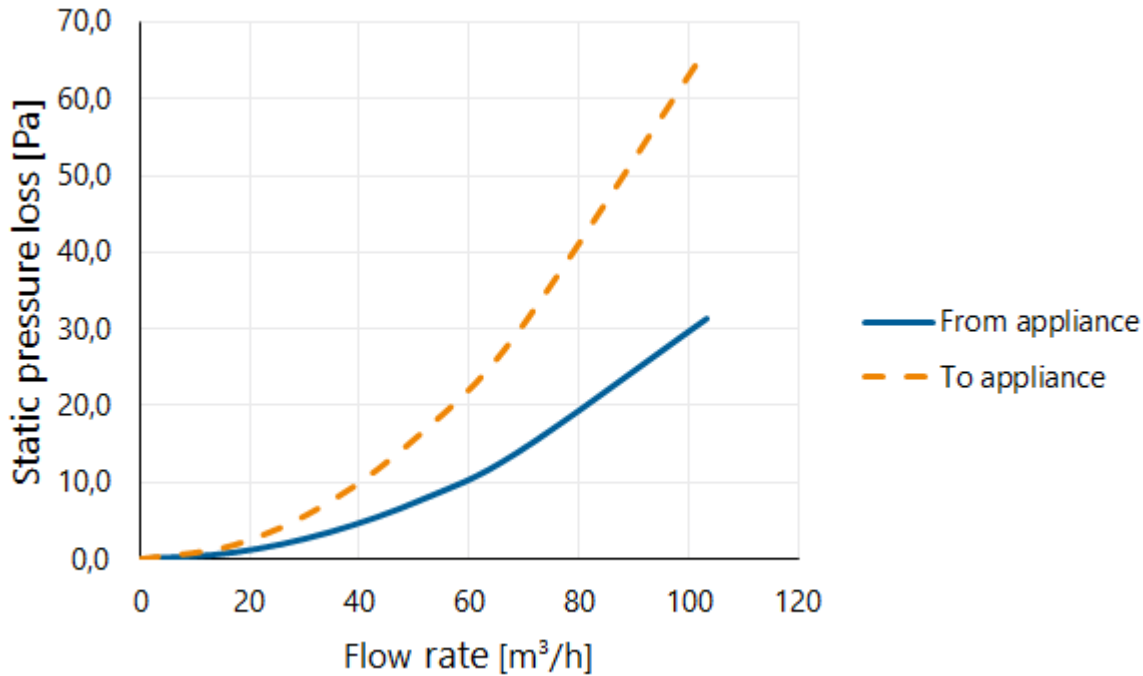

Disc valve with valve connection 125 92 90° (400480616)

Flow velocity pressure table

Flow rate			Static pressure loss		
[m/s]	[m³/h]	[l/s]	From appliance [Pa]	To appliance [Pa]	To app. with filter [Pa]
0	0	0	0,0	0,0	0,0
1	17	5	0,9	1,8	4,8
2	34	10	3,5	7,4	19,3
3	52	14	7,8	16,6	43,3
4	69	19	13,9	29,6	77,0
6	103	29	31,3	66,6	173,3