



Data Sheet 2.07 Issue A

Water Flow Detector Model: WF DEN



General Description

The Rapidrop WF DEN series is compatible with pipe diameters ranging from 50mm through 200mm and can be mounted in a vertical or horizontal position.

Product Description

The WF DEN Series water flow detectors from Rapidrop consists of a rugged, IP56-rated enclosure that is more damage resistant than previous metal designs. The water flow detector is designed for both indoor and outdoor use, with the widest available temperature range, from 0°C to 68°C (32°F to 55°F).

Models are equipped with tamper-resistant cover screws to prevent un-authorized entry. Inside, two sets of SPDT (Form C) synchronized switches are enclosed in a durable terminal block with new layout designed to make wiring easy with wire ready terminals, COM terminals are on a different elevation, large barrier between switches and easy to read raised textured lettering all make wiring easy. An optional cover tamper switch is available, securely snaps into place, no tools required.

The WF DEN series incorporates a mechanical time delay feature, which minimizes the risk of false alarm due to pressure surges or air trapped in the fire sprinkler system. The larger and easy to turn timer dial makes setting the water flow detector easy with high contrast pad printed markings and three tabs to help with turning.

The WF DEN series is designed for accuracy and repeatability. The detector also offers improved performance during vibration in riser applications where detectors are exposed to a large in rush of water.

Engineering Specifications

Vane-type water flow detectors shall be installed on system piping as designated on the drawing and/or as specified herein. Detectors shall mount on any clear pipe span of the appropriate nominal size, either a vertical upflow or horizontal run, at least 15 cm (6 in) from any fittings that may change water direction, flow rate, or pipe diameter or no closer than 61 cm (24 in) from a valve or drain. The detector shall respond to water flow in the specified direction after a preset time delay that is field adjustable. The delay mechanism shall be a sealed mechanical pneumatic unit with visual and audible indication of actuation. The actuation mechanism shall include a ethylene vinyl acetate vane inserted through a hole in the pipe and connected by a mechanical linkage to the delay mechanism. Outputs shall consist of dual SPDT switches (Form C contacts). Two conduit entrances for standard fittings of commonly used electrical conduit shall be provided on the detectors. A grounding provision is provided. Unless noted, enclosures shall be IP56-rated. All detectors shall be Factory Mutual for indoor or outdoor use.

Test/Approvals

FM Approved, LPCB, VdS and CE



Features

- Compliant with Construction Products Regulation
- New directional cover allows installers and inspectors to easily see the direction of flow.
- European models are IP56 rated
- New cover provides a better seal, is lighter weight, not painted and corrosion resistant.
- Sealed retard mechanism immune to dust and other contaminants
- Less exposed metal reduces shock hazard, plastic cover acts as insulator and is resistant to arcing.
- Visual switch activation
- Audible switch activation (73 dBA)
- Field-replaceable timer/switch assembly.
- Accommodates up to 12 AWG wire
- 100 percent synchronization activates both alarm panel and local bell or horn strobe.
- Tamper-resistant cover screws
- Improved water sealing
- Reduced product weight
- Wire-ready terminals
- Improved wiring with new terminal block layout
- Snap-in optional cover tamper switch
- Timer repeatability
- Dial accuracy

Manufactured by System Sensor who have the FM Approval and LPCB, VdS and CE Certification

DS: 2.07
Issue A
15/01/2016
© 2016 Rapidrop

Rapidrop Global Ltd
T: +44 (0) 1733 847 510 F: +44 (0) 1733 553 958
e: rapidrop@rapidrop.com
w: www.rapidrop.com



Data Sheet 2.07 Issue A



Water Flow Detector Model: WFDEN



Standard Specifications

Static Pressure Rating	LPC: 17.25 BAR (250 PSI) VdS: PN16 (16 BAR, 232 PSI)
Maximum Surge	5.5 meters per second (8 ft/s)
Triggering Threshold Bandwidth (Flow Rate)	30-57 litres per minute (6.6-12.5 gpm)
Conduit Entrances	Two openings 22.2 mm (.875 in.) diameter. One open, one knock-out type
Contact Ratings	Two sets of SPDT (Form C) 10.0 A, ½ HP @ 125/250 VAC 2.5 A @ 6/12/24 VDC
Operating Temperature Range	0°C to 49°C (32°F to 120°F)
Enclosure Rating*	IP56
Cover Tamper Switch	Standard with ULC models, optional for UL and European models, part no. CTS

*Maximum pressure rating 400 psi as approved by Factory Mutual.

Dimensions

Model	Pipe Size	Hole Size
WFD20EN	50 mm (2")	31.8 mm (1¼")
WFD25EN	65 mm (2½") (76 mm (2") o.d)	31.8 mm (1¼")
WFD30EN	80 mm (3")	50.8 mm (2")
WFD40EN	100 mm (4")	50.8 mm (2")
WFD60EN	150 mm (6")	50.8 mm (2")
WFD80EN	200 mm (8")	50.8 mm (2")

Delay Adjustment Dial

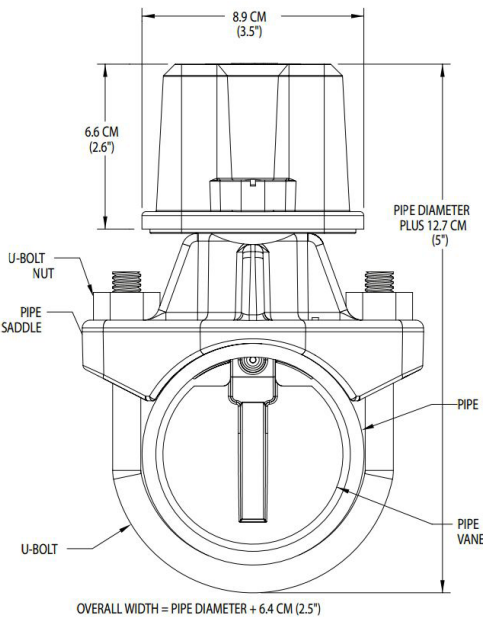
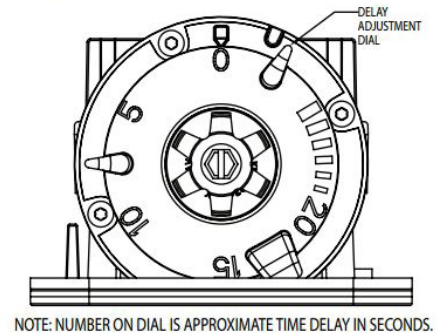

Field Wiring Diagram

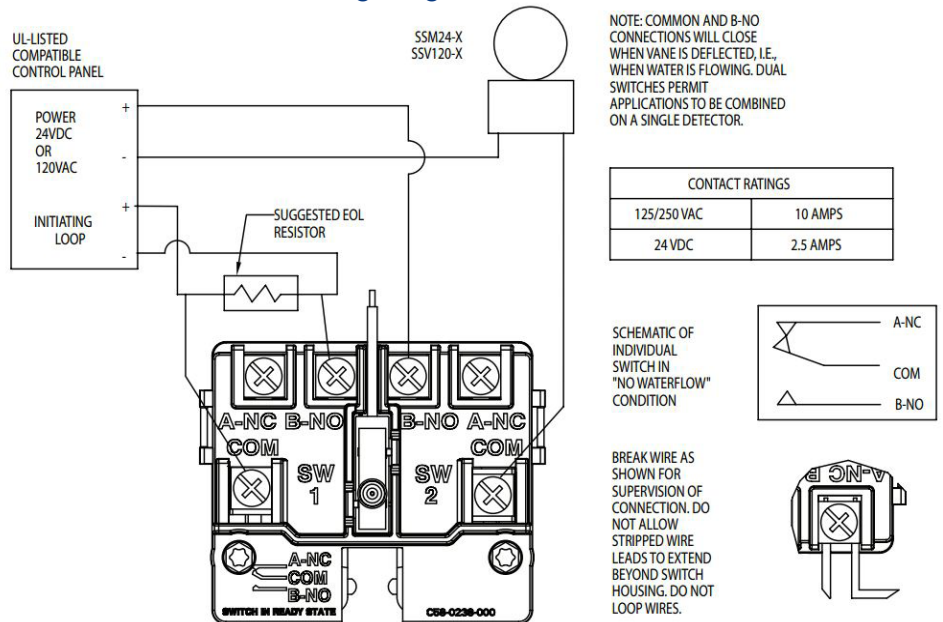

Manufactured by System Sensor who have the FM Approval and LPCB, VdS and CE Certification

DS: 2.07
Issue A
15/01/2016
© 2016 Rapidrop

Rapidrop Global Ltd
T: +44 (0) 1733 847 510 F: +44 (0) 1733 553 958
e: rapidrop@rapidrop.com
w: www.rapidrop.com