

## DI GROOVED FITTINGS-90° ELBOW

Type: 90

Doc No: DS-400-90-01-E

### 1.0 PRODUCT OVERVIEW

The 90° elbow is used for grooved pipe connections for connection at the bend of the pipe and changing the direction of the pipe.



#### Dimensions:

1"(DN25)– 24"(DN600)

#### Design Standard:

ISO6182, AWWA C606, GB 5135.11

#### Connection Standard:

ASME B36.10, ASTM A53-A53M, ISO 4200

#### Working Pressure:

175PSI-500PSI

#### Application:

The 90° elbow is suitable for medium and low pressure pipeline systems with nominal pressure 175-500 PSI, nominal size DN25-DN600, temperature range of -20 °C-+180°C, which are widely applied in water supply and drainage, fire-fighting, air conditioning, etc.

#### Pipe Material:

Welded and seamless rolled steel pipes according to ASME B36.10, ASTM A53-A53M, ISO 4200, GB/T 21835

#### Surface Treatment:

Electrophoretic painting

#### Sign Off:

Owner: \_\_\_\_\_ Contractor: \_\_\_\_\_

Engineer: \_\_\_\_\_

Location: \_\_\_\_\_ Date: \_\_\_\_\_

Approved & Date: \_\_\_\_\_

- Epoxy power painting
- Hot-dip galvanizing
- Black
- Others would be available upon clients' detailed request

## 2.0 APPROVALS



## 3.0 SPECIFICATIONS-MATERIAL

ASTM A536, Ductile iron according to 65-45-12. The nodularity is more than 90%, ensuring excellent physical and mechanical properties

## 4.0 DIMENSIONS AND PERFORMANCE

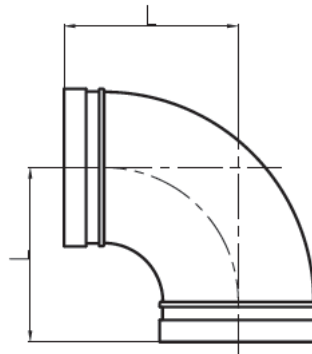

**Sign Off:**

Owner: \_\_\_\_\_ Contractor: \_\_\_\_\_  
 Location: \_\_\_\_\_ Date: \_\_\_\_\_

Engineer: \_\_\_\_\_  
 Approved & Date: \_\_\_\_\_

Nominal Size	Pipe O.D.	Working Pressure	Dimensions L	Nominal Size	Pipe O.D.	Working Pressure	Dimensions L
mm/in	mm/in	PSI/MPa	mm/in	mm/in	mm/in	PSI/MPa	mm/in
25 1	33.7 1.315	500 3.45	57 2.24	200 8	219.1 8.625	500 3.45	197 7.75
32 1¼	42.4 1.66	500 3.45	70 2.75	250 10	267.4 10.528	300 2.07	229 9
40 1½	48.3 1.9	500 3.45	70 2.75	250 10	273 10.75	300 2.07	229 9
50 2	60.3 2.375	500 3.45	82.5 3.25	300 12	318.5 12.539	300 2.07	254 10
65 2½	73 2.875	500 3.45	95 3.74	300 12	323.9 12.75	300 2.07	254 10
65 2½	76.1 3	500 3.45	95 3.74	350 14	355.6 14	300 2.07	280 11.02
80 3	88.9 3.5	500 3.45	108 4.25	350 14	377 14.84	300 2.07	279 10.98
100 4	114.3 4.5	500 3.45	127 5	400 16	406.4 16	300 2.07	305 12
125 5	133 5.25	500 3.45	122 4.8	400 16	426 16.77	300 2.07	305 12
125 5	139.7 5.5	500 3.45	140 5.5	450 18	457.2 18	300 2.07	394 15.5
125 5	141.3 5.563	500 3.45	140 5.5	450 18	480 18.9	300 2.07	335 13.19
150 6	165.1 6.5	500 3.45	165 6.5	500 20	508 20	300 2.07	438 17.25
150 6	168.3 6.625	500 3.45	165 6.5	600 24	609.6 24	300 2.07	508 20

## 5.0 REFERENCE MATERIALS

Approved certification for Grooved Fittings and Couplings

I-JM-Grooved fitting: Installation Instructions for grooved fittings and couplings

**Sign Off:**

Owner: \_\_\_\_\_ Contractor: \_\_\_\_\_

Engineer: \_\_\_\_\_

Location: \_\_\_\_\_ Date: \_\_\_\_\_

Approved & Date: \_\_\_\_\_