



WSAN-YMi

91 - 141



MANUAL

FOR INSTALLATION,
USE AND MAINTENANCE

Cascade unit

Domestic Hot Water

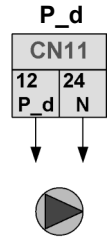
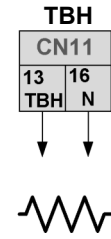
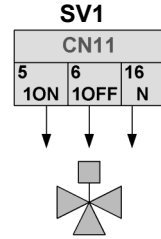
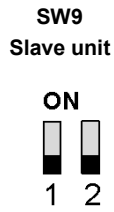
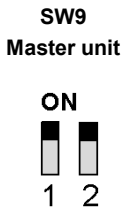
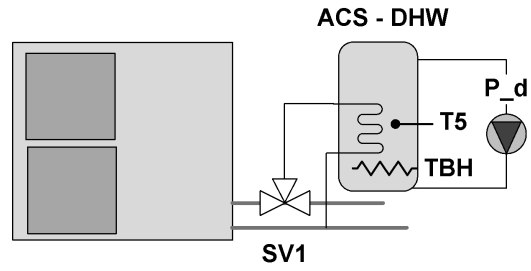
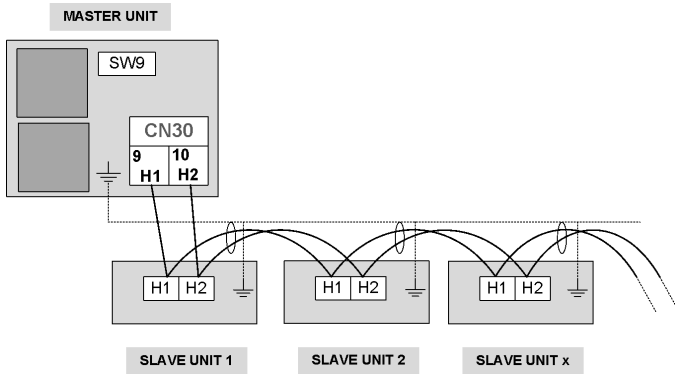

MENU
FOR SERVICEMAN
CASCADE SET



MENU
FOR SERVICEMAN
DHW MODE SETTING



Boiler

Solar panels

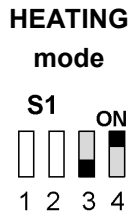
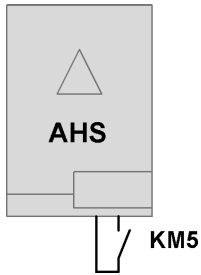

HEATING + DHW mode

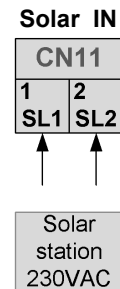
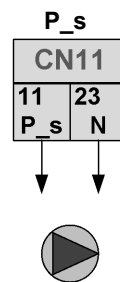
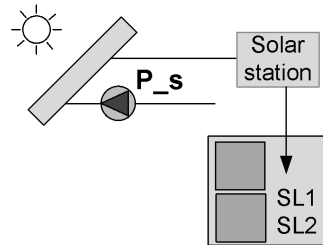
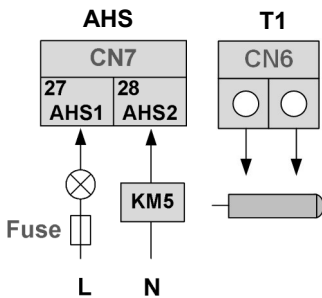
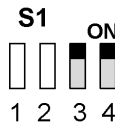

MENU
FOR SERVICEMAN
OTHER HEATING SOURCE



MENU
FOR SERVICEMAN
OTHER HEATING SOURCE



Running signal

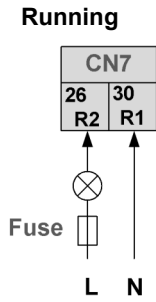

Thermostat

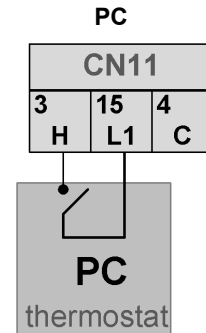

Defrosting signal

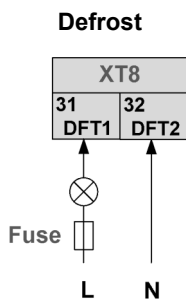

MENU

FOR SERVICEMAN
ROOM THERMOSTAT = YES
MODE SETTING = YES



2-zone system - mixed

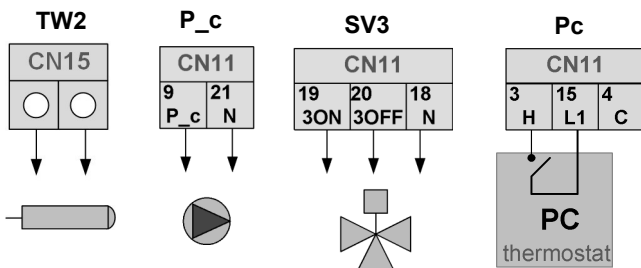
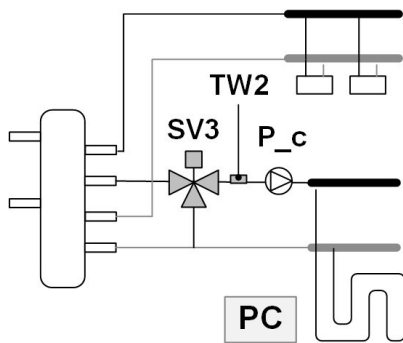

2-zone system - not mixed

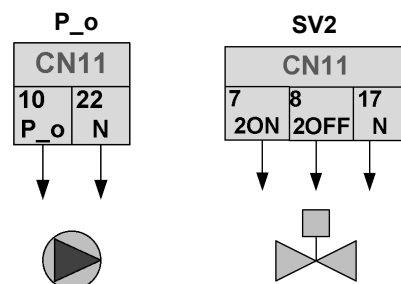
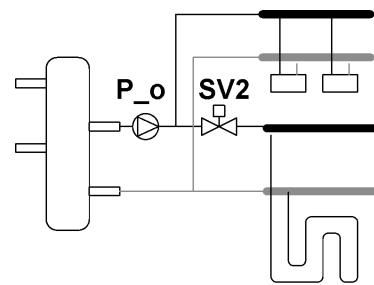

Dear Customer,

We congratulate you on choosing this product

For many years Clivet has been offering systems that provide maximum comfort, together with high reliability, efficiency, quality and safety.

The aim of the company is to offer advanced systems, that assure the best comfort, reduce energy consumption and the installation and maintenance cost for the life cycle of the system.

The purpose of this manual is to provide you with information that is useful from reception of the equipment, through installation, operational usage and finally disposal so that this advanced system offers the best solution.

Yours faithfully.

CLIVET Spa

The data contained in this manual is not binding and may be changed by the manufacturer without prior notice.
Reproduction, even in part, is FORBIDDEN © Copyright - CLIVET S.p.A. - Feltre (BL) - Italia

CONTENTS

1	Product line-up	6
2	Safety considerations	7
3	General information	11
4	Installation	14
5	Water connections	19
6	Electrical connections	27
7	Start-up and configuration	41
8	Service information	61
9	Maintenance	65
10	Trouble shooting	67
11	Controller user manual	78
12	Controller navigation menu	104
13	Cascade function	107
14	Modbus	110
15	General technical data	121
	Dimensional drawings	

Product line-up			
Size	Nominal kW	Power supply	
91	18	400TN	3-phase
101	22	400TN	3-phase
121	26	400TN	3-phase
141	30	400TN	3-phase

2 SAFETY PRECAUTIONS

The precautions listed here are divided into the following types. They are quite important, so be sure to follow them carefully. Meanings of DANGER, WARNING, CAUTION and NOTE symbols.

DANGER

Indicates an imminently hazardous situation which if not avoided, will result in death or serious injury.

WARNING

Indicates a potentially hazardous situation which if not avoided, could result in death or serious injury.

CAUTION

Indicates a potentially hazardous situation which if not avoided, may result in minor or moderate injury. It is also used to alert against unsafe practices.

NOTE

Indicates situations that could only result in accidental equipment or property damage.

WARNING

- Read these instructions carefully before installation. Keep this manual in a handy for future preference.
- Improper installation of equipment or accessories may result in electric shock, short-circuit, leakage, fire or other damage to the equipment. Be sure to only use accessories made by the supplier, which are specifically designed for the equipment and make sure to get installation done by a professional.
- All the activities described in this manual must be carried out by a licensed technician. Be sure to wear adequate personal protection equipment such as gloves and safety glasses while installation the unit or carrying out maintenance activities.
- qualificato devono essere effettuate sotto la supervisione della persona competente per l'uso di refrigeranti infiammabili.
- Servicing shall only be performed as recommended by the equipment manufacturer. Maintenance and repair requiring the assistance of other skilled personnel shall be carried out under the supervision of the person competent in the use of flammable refrigerants.
- Contact your dealer for any further assistance.



Caution: Risk of fire/flammable materials

DANGER

Before touching electric terminal parts, turn off power switch.

When service panels are removed, live parts can be easily touched by accident.

Never leave the unit unattended during installation or servicing when the service panel is removed.

Do not touch water pipes during and immediately after operation as the pipes may be hot and could burn your hands. To avoid injury, give the piping time to return to normal temperature or be sure to wear protective gloves.

Do not touch any switch with wet fingers. Touching a switch with wet fingers can cause electrical shock.

Before touching electrical parts, turn off all applicable power to the unit.

WARNING

- Tear apart and throw away plastic packaging bags so that children will not play with them. Children playing with plastic bags face danger of death by suffocation.
- Safely dispose of packing materials such as nails and other metal or wood parts that could cause injuries.
- Ask your dealer or qualified personnel to perform installation work in accordance with this manual. Do not install the unit yourself. Improper installation could result in water leakage, electric shocks or fire
- Be sure to use only specified accessories and parts for installation work. Failure to use specified parts may result in water leakage, electric shocks, fire, or the unit falling from its mount.
- Install the unit on a foundation that can withstand its weight. Insufficient physical strength may cause the equipment to fall and possible injury.
- Perform specified installation work with full consideration of strong wind, hurricanes, or earthquakes. Improper installation work may result in accidents due to equipment falling.
- Make certain that all electrical work is carried out by qualified personnel according to the local laws and regulations and this manual using a separate circuit. Insufficient capacity of the power supply circuit or improper electrical construction may lead to electric shocks or fire.
- Be sure to install a ground fault circuit interrupter according to local laws and regulations. Failure to install a ground fault circuit interrupter may cause electric shocks and fire.
- Make sure all wiring is secure. Use the specified wires and ensure that terminal connections or wires are protected from water and other adverse external forces. Incomplete connection or affixing may cause a fire.
- When wiring the power supply, form the wires so that the front panel can be securely fastened. If the front panel is not in place there could be overheating of the terminals, electric shocks or fire.
- After completing the installation work, check to make sure that there is no refrigerant leakage.
- Never directly touch any leaking refrigerant as it could cause severe frostbite. Do not touch the refrigerant pipes during and immediately after operation as the refrigerant pipes may be hot or cold, depending on the condition of the refrigerant flowing through the refrigerant piping, compressor and other refrigerant cycle parts. Burns or frostbite are possible if you touch the refrigerant pipes. To avoid injury, give the pipes time to return to normal temperature or, if you must touch them be sure to wear protective gloves.
- Do not touch the internal parts (pump, backup heater, etc.) during and immediately after operation. Touching the internal parts can cause burns. To avoid injury, give the internal parts time to return to normal temperature or, if you must touch them, be sure to wear protective gloves.

2 SAFETY PRECAUTIONS

CAUTION

- Ground the unit.
- Grounding resistance should be according to local laws and regulations.
- Do not connect the ground wire to gas or water pipes, lightning conductors or telephone ground wires.
- Incomplete grounding may cause electric shocks.
 - Gas pipes : Fire or an explosion might occur if the gas leaks.
 - Water pipes : Hard vinyl tubes are not effective grounds.
 - Lightning conductors or telephone ground wires : Electrical threshold may rise abnormally if struck by a lightning bolt.
- Install the power wire at least 3 feet (1 meter) away from televisions or radios to prevent interference or noise. (Depending on the radio waves, a distance of 3 feet (1 meter) may not be sufficient to eliminate the noise.)
- Do not wash the unit. This may cause electric shocks or fire. The appliance must be installed in accordance with national wiring regulations. If the supply cord is damaged, it must be replaced by the manufacturer, its service agent or similarly qualified persons in order to avoid a hazard.
- Do not install the unit in the following places:
 - Where there is mist of mineral oil, oil spray or vapors. Plastic parts may deteriorate, and cause them to come loose or water to leak.
 - Where corrosive gases (such as sulphurous acid gas) are produced. Where corrosion of copper pipes or soldered parts may cause refrigerant to leak.
 - Where there is machinery which emits electromagnetic waves. Electromagnetic waves can disturb the control system and cause equipment malfunction.
 - Where flammable gases may leak, where carbon fiber or ignitable dust is suspended in the air or where volatile flammables such as paint thinner or gasoline are handled. These types of gases might cause a fire.
 - Where the air contains high levels of salt such as near the ocean.
 - Where voltage fluctuates a lot, such as in factories.
 - In vehicles or vessels.
 - Where acidic or alkaline vapors are present.
- This appliance can be used by children 8 years old and above and persons with reduced physical, sensory or mental capabilities or lack of experience and knowledge if they are supervised or given instruction on using the unit in a safe manner and understand the hazards involved. Children should not play with the unit. Cleaning and user maintenance should not be done by children without supervision.
- Children should be supervised to ensure that they do not play with the appliance. If the supply cord is damaged, it must be replaced by the manufacturer or its service agent or a similarly qualified person.
- DISPOSAL: Do not dispose this product as unsorted municipal waste. Collection of such waste separately for special treatment is necessary. Do not dispose of electrical appliances as municipal waste, use separate collection facilities. Contact your local government for information regarding the collection systems available. If electrical appliances are disposed of in landfills or dumps, hazardous substance can leak into the groundwater and get into the food chain, damaging your health and well-being.
- The wiring must be performed by professional technicians in accordance with national wiring regulation and this circuit diagram. An all-pole disconnection device which has at least 3mm separation distance in all pole and a residual current device(RCD) with the rating not exceeding 30mA shall be incorporated in the fixed wiring according to the national rule.

2 SAFETY PRECAUTIONS

- Confirm the safety of the installation area (walls, floors, etc.) without hidden dangers such as water, electricity, and gas. Before wiring/pipes.
- Before installation , check whether the user's power supply meets the electrical installation requirements of unit (including reliable grounding , leakage , and wire diameter electrical load, etc.). If the electrical installation requirements of the product are not met, the installation of the product is prohibited until the product is rectified.
- When installing multiple air conditioners in a centralized manner, please confirm the load balance of the three-phase power supply, and multiple units are prevented from being assembled into the same phase of the three-phase power supply.
- Product installation should be fixed firmly, Take reinforcement measures, when necessary.

NOTE

About Fluorinated Gasses

This air-conditioning unit contains fluorinated gasses. For specific information on the type of gas and the amount, please refer to the relevant label on the unit itself. Compliance with national gas regulations shall be observed.

Installation, service, maintenance and repair of this unit must be performed by a certified technician.

Product uninstallation and recycling must be performed by a certified technician.

If the system has a leak-detection system installed, it must be checked for leaks at least every 12 months. When the unit is checked for leaks, proper record-keeping of all checks is strongly recommended.

REFRIGERANT INFORMATION

This product has the fluorinated gas, it is forbidden to release to air.

Refrigerant type: R32;

Volume of GWP: 675.

GWP=Global Warming Potential

Model	Factory charged refrigerant volume in the unit	
	Refrigerant/kg	Tonnes CO ₂ equivalent
18	5.00	3.38
22	5.00	3.38
26	5.00	3.38
30	5.00	3.38

CAUTION

This unit contains fluorinated greenhouse gases.

Only certificated person is allowed to do installation, operation and maintenance.

Frequency of Refrigerant Leakage Checks

For unit that contains fluorinated greenhouse gases in quantities of 5 tonnes of CO₂ equivalent or more, but of less than 50 tonnes of CO₂ equivalent, at least every 12 months, or where a leakage detection system is installed, at least every 24 months.

Only certificated person is allowed to do installation, operation and maintenance.

3 GENERAL INFORMATION

These units are used for both heating and cooling applications.

They can be combined with fan coil units, floor heating applications, low temperature high efficiency radiators, domestic hot water tanks (not supplied) and solar kits (not supplied).

A wired controller is supplied with the unit .

Antifreeze function

The unit have a freeze prevention function that uses the heat pump and backup heater (option) to keep the water system safe from freezing in all conditions. Since a power failure may happen when the unit is unattended, It's suggested to use anti-freezing flow switch in the water system. (Refer to Water piping).

Backup heater

The backup heater can increase the heating capacity during cold outdoor temperatures.

The backup heater also serves as a backup in case of malfunctioning and for freeze protection of the outside water piping during winter time.

The standard unit is without backup heater.

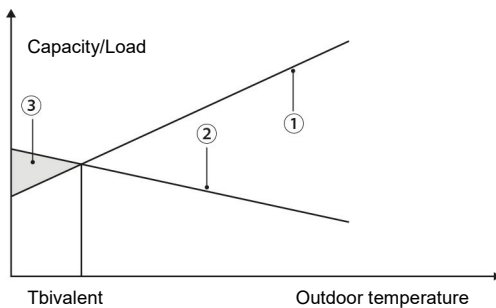

1. Heat pump capacity.
2. Required heating capacity (site dependent).
3. Additional heating capacity provided by backup heater.

Room thermostat

Not supplied

Room thermostat can be connected to the unit(room thermostat should be kept away from heating source when selecting the installation place).

Solar kit for domestic hot water tank

Not supplied

An optional solar kit can be connected to the unit.

Domestic hot water tank

Not supplied.

A domestic hot water tank (with or without booster heater) can be connected to the unit.

See table for specific tank.

If the tank volume is greater than 240L, the temperature probe (T5) should be installed at a position higher than half of the tank's height.

If the tank volume is less than 240L, the temperature probe should be installed at a position higher than 2/3 of the tank's height.

The booster heater should be installed below the temperature probe.

The heat exchanger (coil) should be installed below the temperature probe.

Especially in case of considerable distances between the unit and the DHW storage tank, suitably size the connection pipes and take care of the thermal insulation of the pipes themselves.

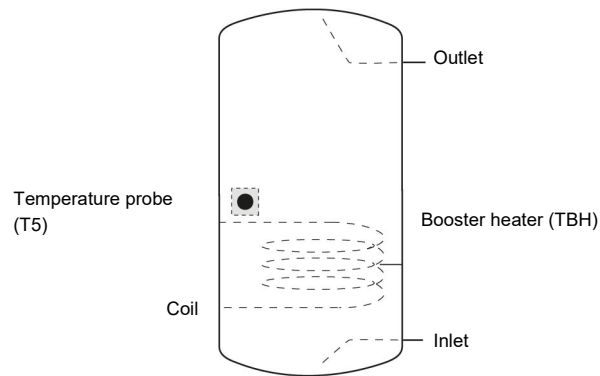

3 GENERAL INFORMATION

Accessories supplied with the unit

Name	Quantity
Adaptor	1
Y-shape filter	1
Water outlet connection pipe assembly	2
Wired controller	1
Tighten belt for customer wiring use	2
Thermistor for domestic hot water tank (T5) *	1
Extension wire for T5	1
Network termination resistor	1

Provided by the customer

Name	Quantity
Thermistor for balance tank (Tbt1)*	1
Thermistor for Zone 2 flow temp. (Tw2)	1
Thermistor for solar temp. (Tsolar)	1

* If the system is installed in parallel, Tbt1 must be connected and installed in the balance tank.

** When the units are connected in parallel, such as when the communication between the unit is unstable (such as an Hd fault code), add a network matching wire between the ports H1 and H2 at the terminal of the communication system;

Sensors Tbt1, T5 and extension wire can be shared, sensors Tw2, Tsolar and extension wire can be shared, if these functions are needed at the same time, please customize these sensors and extension additionally.

Before installation

Be sure to confirm the model name and the serial number of the unit.

Handling

Due to relatively large dimensions and heavy weight, the unit should only be handled using lifting tools with slings. The slings can be fitted into foreseen sleeves at the base frame that are made specifically for this purpose.

CAUTION

To avoid injury, do not touch the air inlet or aluminum fins of the unit.
Do not use the grips in the fan grills to avoid damage.
The unit is top heavy! Prevent the unit from falling due to improper inclination during handling.

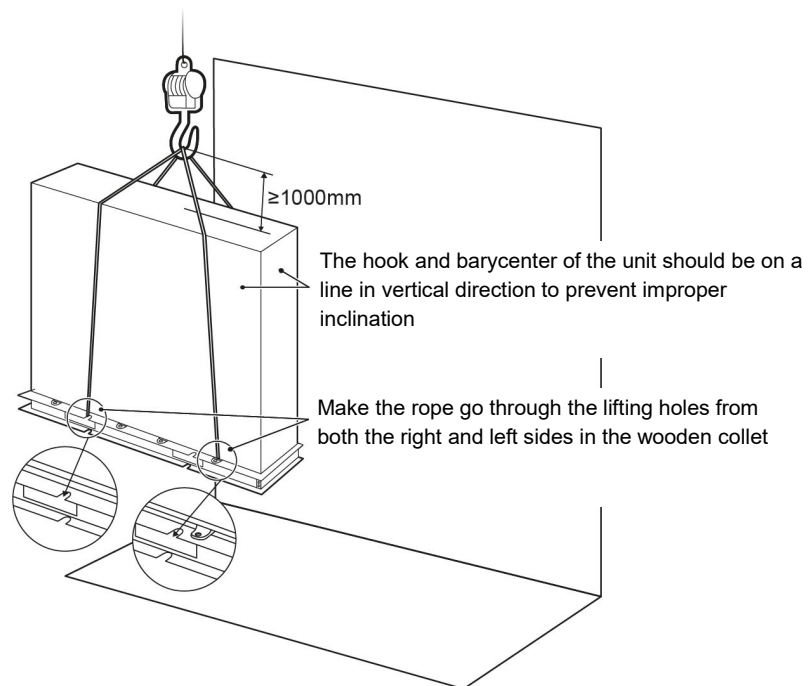

The position of barycenter the unit

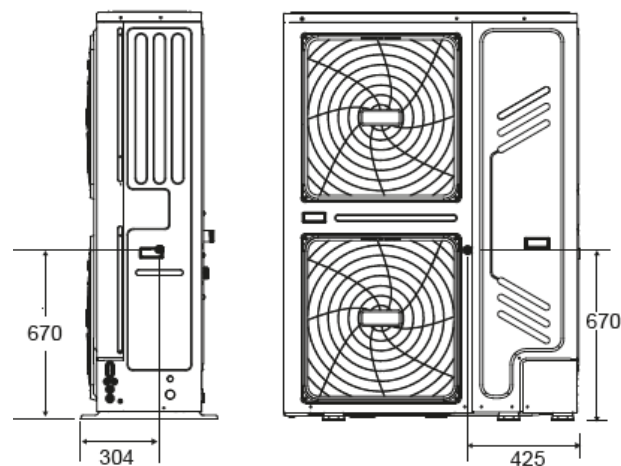

4 INSTALLATION

CAUTION

There is flammable refrigerant in the unit and it should be installed in a well-ventilated site. If the unit is installed inside, an additional refrigerant detection device and ventilation equipment must be added in accordance with the standard EN378.

Be sure to adopt adequate measures to prevent the unit from being used as a shelter by small animals.

Small animals making contact with electrical parts can cause malfunction, smoke or fire.

Please instruct the customer to keep the area around the unit clean.

Select an installation site where the following conditions are satisfied and one that meets with your customer's approval.

- Places that are well-ventilated.
- Places where the unit does not disturb next-door neighbors.
- Safe places which can bear the unit's weight and vibration and where the unit can be installed at an even level.
- Places where there is no possibility of flammable gas or product leak.
- The equipment is not intended for use in a potentially explosive atmosphere.
- Places where servicing space can be well ensured.
- Places where the units' piping and wiring lengths come within the allowable ranges.
- Places where water leaking from the unit cannot cause damage to the location (e.g. in case of a blocked drain pipe).
- Places where rain can be avoided as much as possible.
- Do not install the unit in places often used as a work space. In case of construction work (e.g. grinding etc.) where a lot of dust is created, the unit must be covered.
- Do not place any object or equipment on top of the unit (top plate)
- Do not climb, sit or stand on top of the unit.
- Be sure that sufficient precautions are taken in case of refrigerant leakage according to relevant local laws and regulations.
- Don't install the unit near the sea or where there is corrosion gas.

When installing the unit in a place exposed to strong wind, pay special attention to the following.

Strong winds of 5 m/sec or more blowing against the unit's air outlet causes a short circuit (suction of discharge air), and this may have the following consequences:

- Deterioration of the operational capacity.
- Frequent frost acceleration in heating operation.
- Disruption of operation due to rise of high pressure.
- When a strong wind blows continuously on the front of the unit, the fan can start rotating very fast until it breaks.

In normal condition, refer to the figures below for installation of the unit:

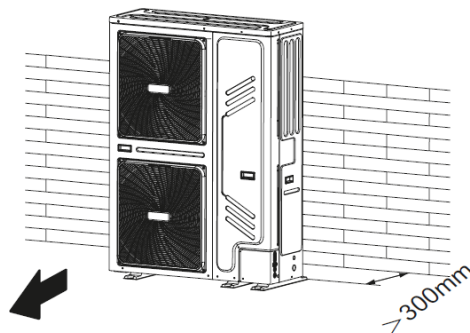

In case of strong wind and the wind direction can be foreseen, refer to the figures below for installation of the unit (any one is OK):

Turn the air outlet side toward the building's wall, fence or screen.

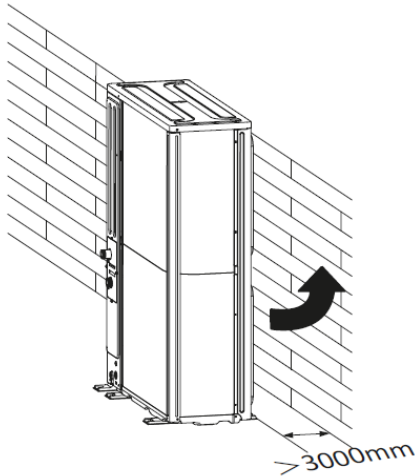

Make sure there is enough room to do the installation.
Set the outlet side at a right angle to the direction of the wind.

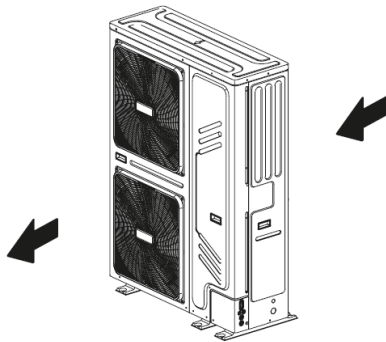

Prepare a water drainage channel around the foundation, to drain waste water from around the unit.

If water does not easily drain from the unit, mount the unit on a foundation of concrete blocks, etc. (the height of the foundation should be about 100 mm (3.93 in)).

If you install the unit on a frame, please install a waterproof plate (about 100 mm) on the underside of the unit to prevent water from coming in from the low side.

When installing the unit in a place frequently exposed to snow, pay special attention to elevate the foundation as high as possible.

If you install the unit on a building frame, please install a waterproof plate (not supplied) (about 100mm, on the underside of the unit) in order to avoid drain water dripping. (See the picture in the right).



NOTE

Unit is top heavy!
Try not to install on the building frame.

Selecting a location in hot climates

As the outdoor temperature is measured via the outdoor unit air thermistor, make sure to install the outdoor unit in the shade or a canopy should be constructed to avoid direct sunlight, so that it is not influenced by the sun's heat, otherwise protection may be possible to the unit.

Selecting a location in cold climates

To prevent exposure to wind, install the unit with its suction side facing the wall.

Never install the unit at a site where the suction side may be exposed directly to wind.

To prevent exposure to wind, install a baffle plate on the air discharge side of the unit.

In heavy snowfall areas, it is very important to select an installation site where the snow will not affect the unit. If lateral snowfall is possible, make sure that the heat exchanger coil is not affected by the snow (if necessary construct a lateral canopy).

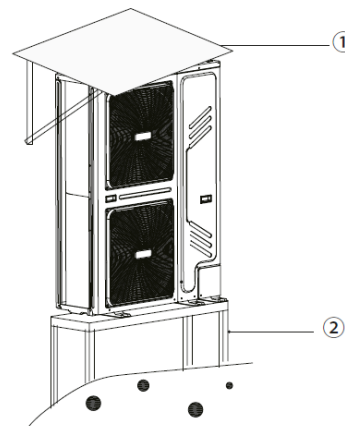

1. Construct a large canopy.
2. Construct a pedestal.

Install the unit high enough off the ground to prevent it from being buried in snow.

4 INSTALLATION

Installation requirements

Check the strength and level of the installation ground so that the unit may not cause any vibrations or noise during its operation. In accordance with the foundation drawing in the figure, fix the unit securely by means of foundation bolts. (Prepare four sets each of $\Phi 10$ Expansion bolts, nuts and washers which are readily available in the market.)
Screw in the foundation bolts until their length is 20 mm from the foundation surface.

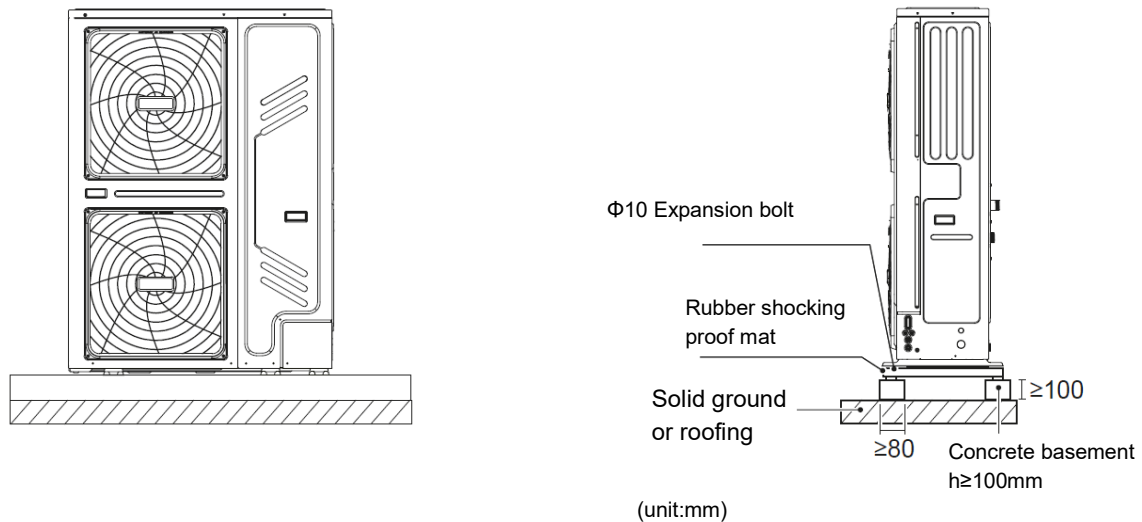

Drain hole position

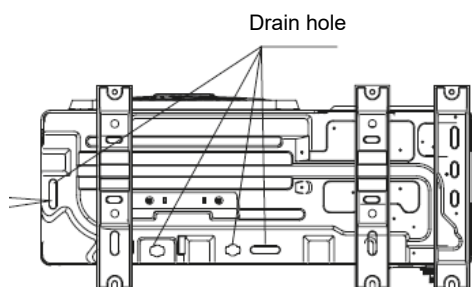

This drain hole is covered by rubber plug. If the small drain hole can not meet the drainage requirements, the big drain hole can be used at the same time.

NOTE

It's necessary to install an electrical heating belt if water can't drain out in cold weather even the big drain hole has opened.

Servicing space requirements

Single unit

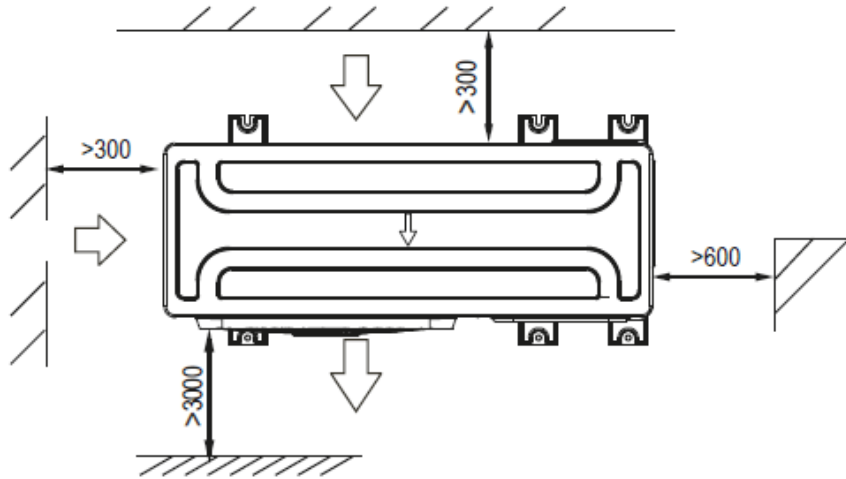

Lateral units in row

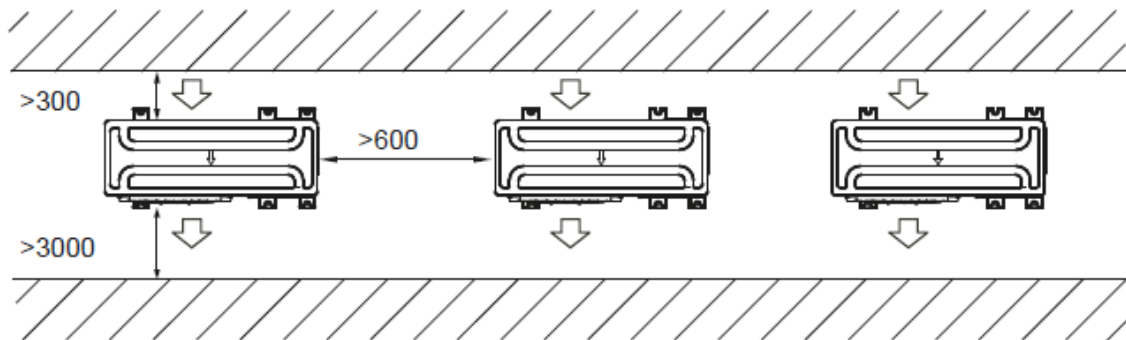

Front units in row

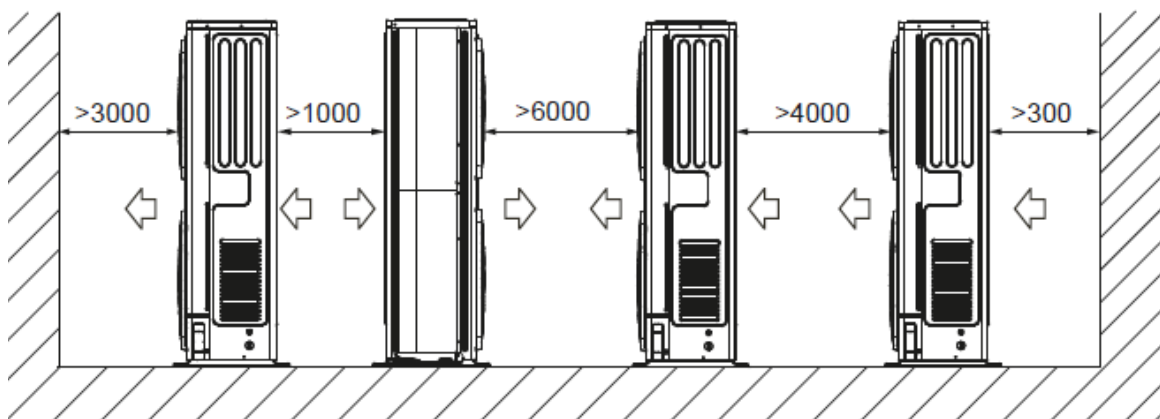

5 WATER CONNECTIONS

Water features

- confirming to local regulations
 - Langelier (IL) index between 0 and +0.4
 - within the limits indicated by table
- The water quality must be checked by qualified personnel.

Water component for corrosion limit on Copper		
PH	7,5 ÷ 9,0	
SO ₄ ²⁻	< 100	
HCO ₃ ⁻ / SO ₄ ²⁻	> 1	
Total Hardness	8 ÷ 15	°f
Cl ⁻	< 50	ppm
PO ₄ ³⁻	< 2,0	ppm
NH ₃	< 0,5	ppm
Free Chlorine	< 0,5	ppm
Fe ₃ ⁺	< 0,5	ppm
Mn ⁺⁺	< 0,05	ppm
CO ₂	< 50	ppm
H ₂ S	< 50	ppb
Temperature	< 65	°C
Oxygen content	< 0,1	ppm
Sand	10 mg/L 0.1 to 0.7mm max diameter	
Ferrite hydroxide Fe ₃ O ₄ (black)	Dose < 7.5 mg/L 50% of mass with diameter < 10 µm	
Iron oxide Fe ₂ O ₃ (red)	Dose < 7.5mg/L	

CAUTION

Circulators operate best with clean, good quality tap water. The most frequently occurring factors which may have a negative effect on heating water can be oxygen, lime, sludge, acidity level and other substances (including chlorides and minerals). In addition to the heating water quality, the installation also plays a significant part.

Hardness

If the water hardness is high install a system suitable to preserve the unit from harmful deposits and limestone formations.

If necessary, fit a water softener to reduce water hardness.

Cleaning

Before making the water connections to unit clean carefully the system with specific and effective products for removing residues or impurities that could affect the operation. The existing systems must be free from sludges, contaminants and protected against foulings.

New heating systems

In the case of new installations, it is first of all crucial to flush the entire installation thoroughly (without the circulator mounted) before the central installation is commissioned. This will remove residues from the installation process (weld, slag, fitting products...) and preservatives (including mineral oil). The system shall then be filled with clean, good quality tap water.

Existing heating systems

If a new boiler or heat pump is being installed in an existing heating system, the system must be flushed to avoid particles presence, sludge and other problems in the installation. Where applicable, flushing shall be done before the new application is installed. Loose dirt can only be removed where there is sufficient flow. Flushing will therefore take place section by section. Special attention must also be paid to "blind spots", where there is only a small amount of flow and where a lot of dirt can be accumulated. The system shall then be filled with clean, good quality tap water. If after the flushing the quality of the water in an existing installation still proves to be inadequate, certain measures must be taken to avoid circulator problems. One option for removing pollution is to install a filter. Various kinds of filters are available for this. A screen filter is designed to trap large dirt particles. This filter is usually placed in the full flow part of the system. A fabric filter on the other hand, is designed to trap finer particles.

Exclusions

The warranty does not cover damages caused by limestone formations, deposits and impurities from the water supply and / or failure from failed system clearing to clean system.

5 WATER CONNECTIONS

Hydraulic module

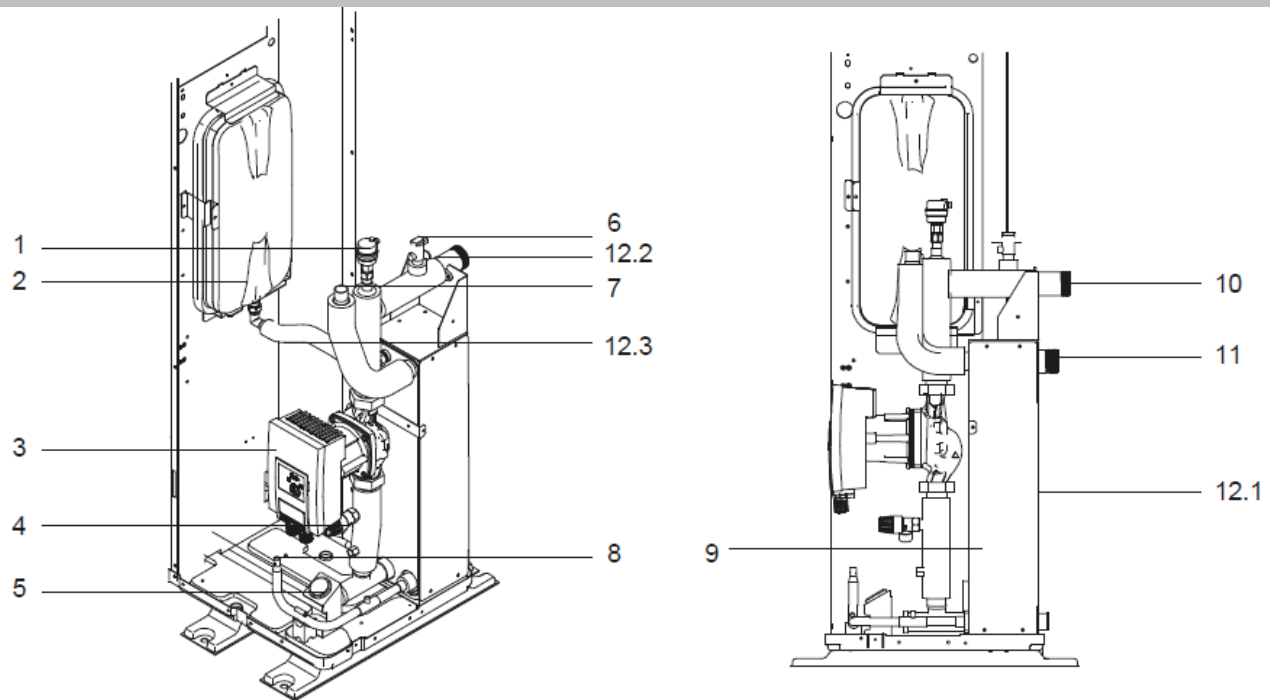

1	Air purge valve
2	Expansion vessel
3	Pump
4	Safety valve
5	Manometer
6	Flow switch
7	Refrigerant gas connection
8	Refrigerant liquid connection
9	Plate heat exchanger
10	Water outlet connection
11	Water inlet connection
12.1	Electrical resistance
12.2	Electrical resistance
12.3	Electrical resistance
TW_out TW_in	Water temperature sensors
T2B T2	Refrigerant temperature sensors

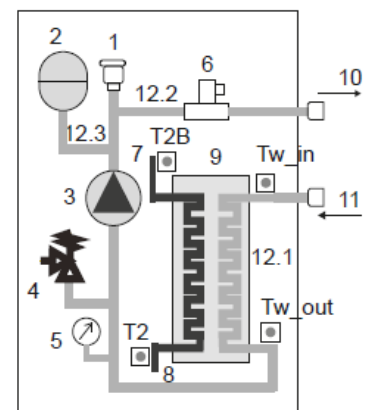

5 WATER CONNECTIONS

Water piping

NOTE

If the installation is equipped with a domestic hot water tank (optional), please refer to the domestic hot water tank Installation And Owner's Manual. If there is no glycol (anti-freeze) in the system there is a power supply or pump failure, drain the system (as shown in the figure below).

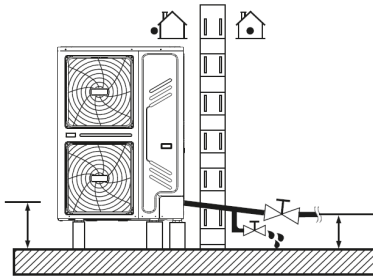

NOTE

If water is not removed from the system in freezing weather when unit is not used. The frozen water may damage the water circle parts.

Check the water circuit

The units are equipped with a water inlet and outlet for connection to a water circuit.

The units should only be connected to closed water circuits.

Connection to an open water circuit would lead to excessive corrosion of the water piping.

Only materials complying with all applicable legislation should be used.

Before continuing installation of the unit, check the following:

- The maximum water pressure ≤ 3 bar.
- The maximum water temperature $\leq 70^{\circ}\text{C}$ according to safety device setting.
- Always use materials that are compatible with the water used in the system and with the materials used in the unit.
- Ensure that components installed in the field piping can withstand the water pressure and temperature.
- Drain taps must be provided at all low points of the system to permit complete drainage of the circuit during maintenance.
- Air vents must be provided at all high points of the system.

The vents should be located at points that are easily accessible for service.

An automatic air purge is provided inside the unit.

Check that this air purge valve is not tightened so that automatic release of air in the water circuit is possible.

Water volume and expansion vessel pre-pressure checks

The units are equipped with an expansion vessel that has a default pre-pressure (see table).

To assure proper operation of the unit, the pre-pressure of the expansion vessel might need to be adjusted.

- 1) Check that the total water volume in the installation, excluding the internal water volume of the unit, is at least 40L . Refer to General technical data to find the total internal water volume of the unit.
- 2) Using the table below, determine if the expansion vessel pre- pressure requires adjustment.
- 3) Using the table and instructions below, determine if the total water volume in the installation is below the maximum allowed water volume.

Installation height difference	Water volume ≤ 230	Water volume > 230
≤ 7	No pre-pressure adjustment required.	Calculate the volume of the expansion vessel based on the height of the system and its actual water content.
$>$	Pre-pressure must be increased, calculate according to "Calculating the pre-pressure of the expansion vessel" below.	Calculate the volume of the expansion vessel based on the height of the system and its actual water content.

NOTE

In most applications this minimum water volume will be satisfactory.

In critical processes or in rooms with a high heat load though, extra water might be required.

When circulation in each space heating loop is controlled by remotely controlled valves, it is important that this minimum water volume is kept even if all the valves are closed.

Height difference is between the highest point of the water circuit and the outdoor unit's expansion tank.

Unless the unit is located at the highest point of the system, in which case the installation height difference is considered to be zero.

Calculating the pre-pressure of the expansion vessel

The pre-pressure (P_g) to be set depends on the maximum installation height difference (H) and is calculated as follows: $P_g(\text{bar}) = (H(\text{m})/10 + 0.3) \text{ bar}$

Checking the maximum allowed water volume

To determine the maximum allowed water volume in the entire circuit, proceed as follows:

- Determine the calculated pre-pressure (P_g) for the corresponding maximum water volume using the graph below.
- Check that the total water volume in the entire water circuit is lower than this value. If this is not the case, the expansion vessel inside the unit is too small for the installation.

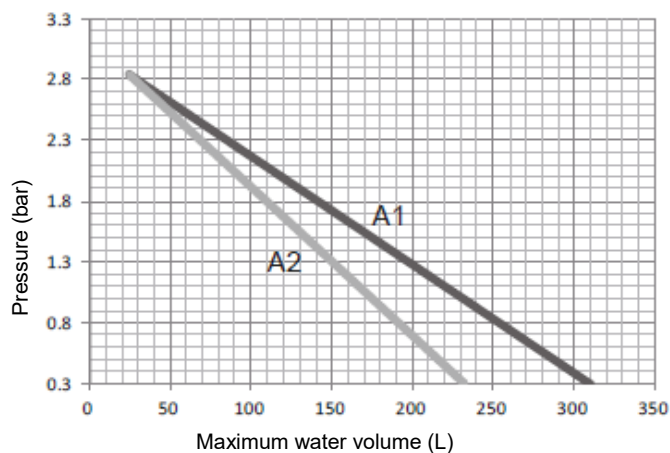

Pre-pressure = pre-pressure of the expansion vessel

Maximum water volume = maximum water volume in the system

A1 System without glycol

A2 System without glycol

5 WATER CONNECTIONS

Example 1 :

The unit (16kW) is installed 5m below the highest point in the water circuit. The total water volume in the water circuit is 100 L. In this example, no action or adjustment is required.

Example 2 :

The unit(16kW) is installed at the highest point in the water circuit. The total water volume in the water circuit is 250 L.

Result:

Since 250 L is more than 230 L, the pre-pressure must be decreased (see table above).

- The required pre-pressure is: $P_g(\text{bar}) = (H(\text{m})/10+0.3) \text{ bar} = (0/10+0.3) \text{ bar} = 0.3 \text{ bar}$
- The corresponding maximum water volume can be read from the graph: approximately 160 L.
- Since the total water volume (250 L) is below the maximum water volume (310 L), the expansion vessel suffices for the installation.

Setting the pre-pressure of the expansion vessel

When it is required to change the default pre-pressure of the expansion vessel (1.5 bar), following guidelines:

- Use only dry nitrogen to set the expansion vessel pre-pressure.
- Inappropriate setting of the expansion vessel pre-pressure will lead to malfunctioning of the system. Pre-pressure should only be adjusted by a licensed installer.

Selecting the additional expansion vessel

If the expansion vessel of the unit is too small for the installation, an additional expansion vessel is needed.

- calculate the pre-pressure of the expansion vessel:

$$P_g(\text{bar})=(H(\text{m})/10+0.3) \text{ bar}$$

the expansion vessel equipped in the unit should adjust the pre- pressure also.

- calculate the volume needed of the additional expansion vessel:

$$V1=0.0693*V_{\text{water}}/(2.5-P_g)-V0$$

V_{water} is volume of water in the system, $V0$ is volume of expansion vessel which the unit is equipped(8L).

CAUTION

Be careful not to deform the unit's piping by using excessive force when connecting the piping. Deforming the piping can cause the unit to malfunction.

If air, moisture or dust gets in the water circuit, problems may occur. Therefore, always take into account the following when connecting the water circuit:

- Use clean pipes only.
- Hold the pipe end downwards when removing burrs.
- Cover the pipe end when inserting it through a wall to prevent dust and dirt entering.
- Use a good thread sealant for sealing the connections. The sealing must be able to withstand the pressures and temperatures of the system.
- When using non-copper metallic piping, be sure to insulate two kind of materials from each other to prevent galvanic corrosion.
- For copper is a soft material, use appropriate tools for connecting the water circuit. Inappropriate tools will cause damage to the pipes.

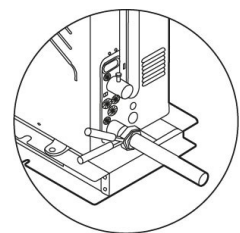

NOTE

The unit is only to be used in a closed water system. Application in an open water circuit can lead to excessive corrosion of the water piping:

- Never use Zn-coated parts in the water circuit. Excessive corrosion of these parts may occur as copper piping is used in the unit's internal water circuit.
- When using a 3-way valve in the water circuit. Preferably choose a ball type 3-way valve to guarantee full separation between the domestic hot water and floor heating water circuit.
- When using a 3-way valve or a 2-way valve in the water circuit. The recommended maximum changeover time of the valve should be less than 60 seconds.

Water circuit anti-freeze protection

Ice formation can cause damage to the hydraulic system. As the outdoor unit may be exposed to sub-zero temperatures, care must be taken to prevent freezing of the system.

All internal hydronic parts are insulated to reduce heat loss. Insulation must also be added to the field piping.

- The software contains special functions using the heat pump to protect the entire system against freezing. When the temperature of the water flow in the system drops to a certain value, the unit will heat the water, either using the heat pump, the electric heating tap, or the backup heater. The freeze protection function will turn off only when the temperature increases to a certain value.

In event of a power failure, the above features would not protect the unit from freezing.

Since a power failure could happen when the unit is unattended, the recommends use anti-freeze fluid to the water system.

Depending on the expected lowest outdoor temperature, make sure the water system is filled with a concentration of glycol as mentioned in the table below.

When glycol is added to the system, the performance of the unit will be affected.

The correction factor of the unit capacity, flow rate and pressure drop of the system is listed in the table below.

Ethylene Glycol

Quality of glycol/%	Modification coefficient				Freezing point/°C
	Cooling capacity modification	Power modification	Water resistance	Water flow modification	
0	1.000	1.000	1.000	1.000	0
10	0.984	0.998	1.118	1.019	-5
20	0.973	0.995	1.268	1.051	-15
30	0.965	0.992	1.482	1.092	-25

Propylene Glycol

Quality of glycol/%	Modification coefficient				Freezing point/°C
	Cooling capacity modification	Power modification	Water resistance	Water flow modification	
0	1.000	1.000	1.000	1.000	0
10	0.976	0.996	1.071	1.000	-4
20	0.961	0.992	1.189	1.016	-12
30	0.948	0.988	1.380	1.034	-20

If no glycol is added, the water must be drained out when there is a power failure.

Water may enter into the flow switch and cannot be drained out and may freeze when the temperature is low enough.

The flow switch should be removed and dried, then can be reinstalled in the unit.

WARNING

Ethylene Glycol and Propylene Glycol are TOXIC

The concentrations mentioned in the table above will not prevent freezing, but will prevent the hydraulics from bursting.

5 WATER CONNECTIONS

NOTE

Counterclockwise rotation, remove the flow switch.
Drying the flow switch completely.

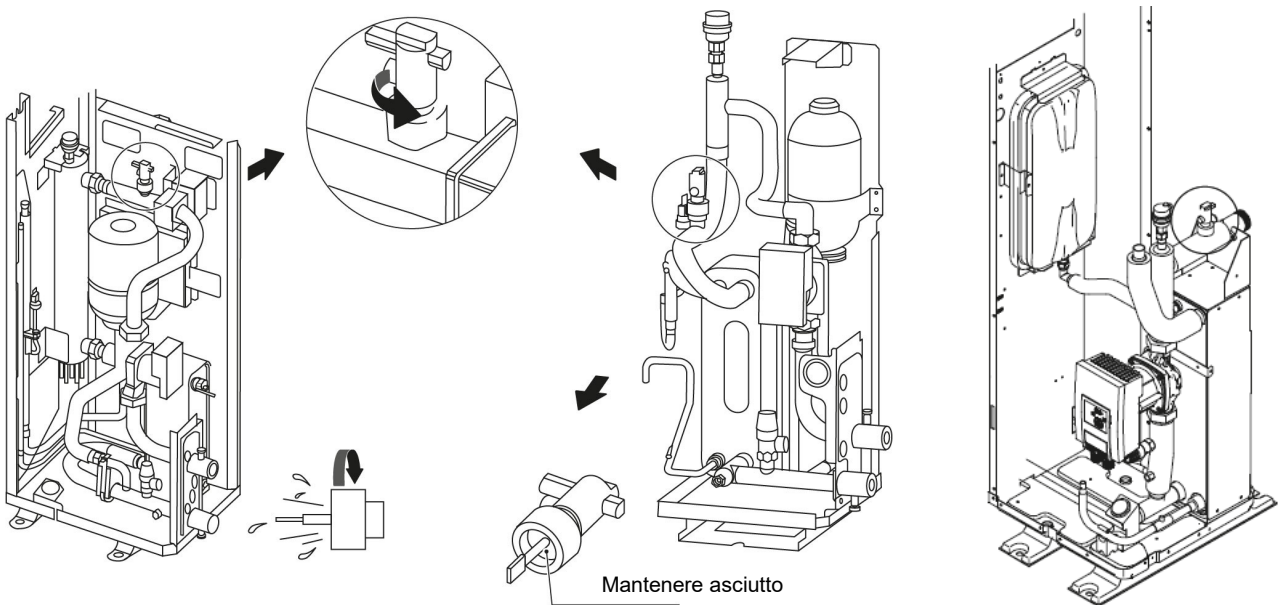

CAUTION

Use of glycol

Glycol use for installations with a domestic hot water tank: Only propylene glycol having a toxicity rating or class of 1, as listed in "Clinical Toxicology of Commercial Products, 5th edition" may be used. The maximum allowed water volume is then reduced according to the figure on page 45.

If there is too much pressure when using glycol, connect the safety valve to a drain pan to recover the glycol.

NOTE

Be aware of the hygroscopic property of glycol. It absorbs moisture from the environment.

Leaving the cap off the glycol container causes the concentration of water to increase. The glycol concentration is then lower and the water could freeze.

Preventive actions must be taken to ensure minimal exposure of the glycol to air.

Corrosion in the system due to glycol

Uninhibited glycol will turn acidic under the influence of oxygen. This process is accelerated by presence of copper and at higher temperatures. The acidic uninhibited glycol attacks metal surfaces and forms galvanic corrosion cells that cause severe damage to the system.

- It is of extreme importance:
- That the water treatment is correctly executed by a qualified water specialist.
- That a glycol with corrosion inhibitors is selected to counteract acids formed by the oxidation of glycols.
- That in case of an installation with a domestic hot water tank, only the use of propylene glycol is allowed. In other installations the use of ethylene glycol is fine.
- That no automotive glycol is used because their corrosion inhibitors have a limited lifetime and contain silicates that can foul or plug the system.
- That galvanized piping is not used in glycol systems since it may lead to the precipitation of certain elements in the glycol's corrosion inhibitor.
- To ensure that the glycol is compatible with the materials used in the system.

Adding water

- Connect the water supply to the fill valve and open the valve.
- Make sure the automatic air purge valve is open (at least 2 turns).
- Fill with water until the manometer indicates a pressure of approximately 2.0 bar. Remove air in the circuit as much as possible using the air purge valves. Air in the water circuit could lead to malfunction of the backup electric heater.

Do not fasten the black plastic cover on the vent valve at the top side of the unit when the system is running.
Open air purge valve, turn anticlockwise at least 2 full turns to release air from the system.

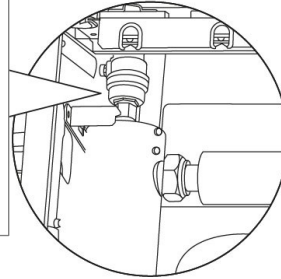

NOTE

During filling, it might not be possible to remove all air in the system.

Remaining air will be removed through the automatic air purge valves during the first operating hours of the system.

Topping up the water afterwards might be required.

The water pressure indicated on the manometer will vary depending on the water temperature (higher pressure at higher water temperature).

However, at all times water pressure should remain above 0.3 bar to avoid air entering the circuit.

The unit might drain-off too much water through the pressure relief valve.

Water quality must be according to "Safe Drinking water Act".

Piping insulation

The complete water circuit including all piping, must be insulated to prevent:

- condensation during cooling operation
- reduction of the heating and cooling capacity
- freezing of the outside water piping during winter.

The thickness of the sealing materials must be at least 13 mm with $\lambda = 0.039$ W/mK in order to prevent freezing on the outside water piping.

If the temperature is higher than 30°C and the humidity is higher than RH 80%, then the thickness of the sealing materials should be at least 20 mm in order to avoid condensation on the surface of the seal.

6 ELECTRICAL CONNECTIONS

WARNING

A main switch or other means of disconnection, having a contact separation in all poles, must be incorporated in the fixed wiring in accordance with relevant local laws and regulations.

Switch off the power supply before making any connections.

Use only copper wires. Never squeeze bundled cables and make sure they do not come in contact with the piping and sharp edges. Make sure no external pressure is applied to the terminal connections.

All field wiring and components must be installed by a licensed electrician and must comply with relevant local laws and regulations.

The field wiring must be carried out in accordance with the wiring diagram supplied with the unit and the instructions given below.

Be sure to use a dedicated power supply.

Never use a power supply shared by another appliance.

Be sure to establish a ground.

Do not ground the unit to a utility pipe, surge protector, or telephone ground. Incomplete grounding may cause electrical shock.

Be sure to install a ground fault circuit interrupter (30 mA).

Failure to do so may cause electrical shock.

Be sure to install the required fuses or circuit breakers.

Precautions on electrical wiring work

- Fix cables so that cables do not make contact with the pipes (especially on the high pressure side).
- Secure the electrical wiring with cable ties as shown in figure so that it does not come in contact with the piping, particularly on the high-pressure side.
- Make sure no external pressure is applied to the terminal connectors.
- When installing the ground fault circuit interrupter make sure that it is compatible with the inverter (resistant to high frequency electrical noise) to avoid unnecessary opening of the ground fault circuit interrupter.

NOTE

The ground fault circuit interrupter must be a high- speed type breaker of 30 mA (<0.1 s).

This unit is equipped with an inverter.

Installing a phase advancing capacitor not only will reduce the power factor improvement effect, but also may cause abnormal heating of the capacitor due to high-frequency waves. Never install a phase advancing capacitor as it could lead to an accident.

Overview

The illustration below gives an overview of the required field wiring between several parts of the installation.

6 ELECTRICAL CONNECTIONS

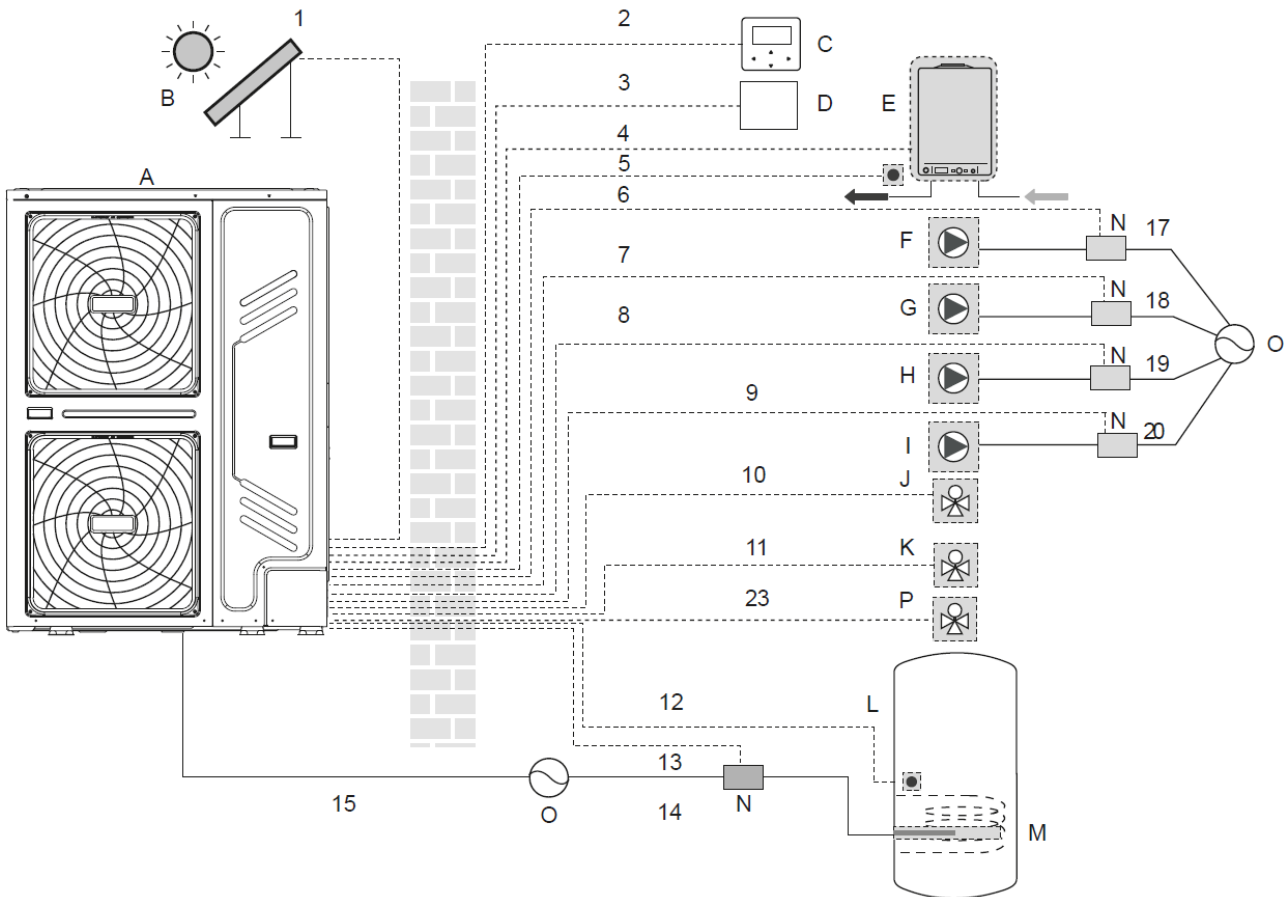

A	Outdoor unit	I	P_d: DHW pump (not supplied)
B	Solar energy kit (not supplied)	J	SV2: 2-way valve (not supplied)
C	User interface	K	SV1: 3-way valve for domestic hot water tank (not supplied)
D	Room thermostat (not supplied)	L	Domestic hot water tank
E	Boiler (not supplied)	M	Booster heater
F	P_s: Solar pump (not supplied)	N	Contactors
G	P_c: Mixing pump (not supplied)	O	Power supply
H	P_o: Outside circulation pump (not supplied)	P	SV2: zone 2 3-way valve (not supplied)

6 ELECTRICAL CONNECTIONS

N.	Description	AC/ DC	N. conductors	Maximum running current
1	Solar energy kit signal cable	AC	2	200mA
2	User interface cable	AC	5	200mA
3	Room thermostat cable	AC	2 or 3	200mA (a)
4	Boiler control cable	/	2	200mA
5	Thermistor cable for Tw2	DC	2	(b)
9	DHW pump control cable	AC	2	200mA (a)
10	2-way valve control cable	AC	2	200mA (a)
10 11 23	3-way valve control cable	AC	2 or 3	200mA (a)
12	Thermistor cable T5	DC	2	(b)
13	Booster heater control cable	AC	2	200mA (a)
15	Power supply cable for unit	AC	3+GND	15A

(a) Minimum cable section AWG18 (0.75 mm²)

(b) The thermistor cable (10m) are delivered with the unit

(c) See SPECIFIC ELECTRICAL CONNECTIONS

NOTE

All the cables are connected to high voltage except for thermistor cable and cable for user interface.

Equipment must be grounded.

All high-voltage external load, if it is metal or a grounded port, must be grounded.

All external load current is needed less than 0.2A, if the single load current is greater than 0.2A, the load must be controlled through AC contactor.

AHS1" "AHS2", "A1" "A2", "R1" "R1" and "DTF1" "DTF2" wiring terminal ports provide only the switch signal.

Expansion valve E-Heating tape, Plate heat exchanger E-Heating tape and Flow switch E-Heating tape share a control port.

Electronic control box

The picture is for reference only

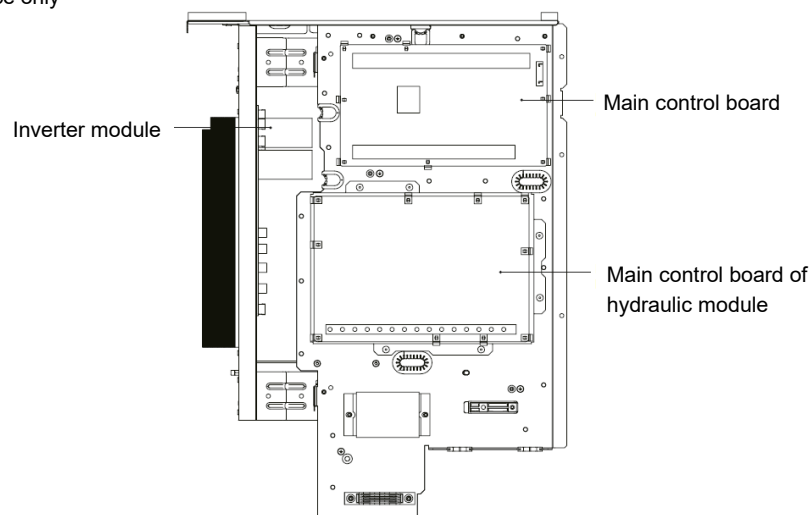

Position connections

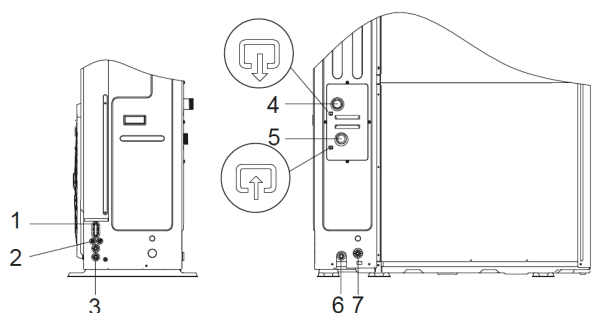

Coding	Assembly unit
1	High voltage wire hole
2	Low voltage wire hole
3	High voltage wire hole / low voltage
4	Water outlet
5	Water inlet
6	Drainage pipe hole
7	Safety valve drainage pipe hole

Field wiring guidelines

- Most field wiring on the unit is to be made on the terminal block inside the switch box. To gain access to the terminal block, remove the switch box service panel (door 2).

WARNING

Switch off all power including the unit power supply and backup heater and domestic hot water tank power supply (if applicable) before removing the switch box service panel.

- Fix all cables using cable ties.
- A dedicated power circuit is required for the backup heater.
- Installations equipped with a domestic hot water tank (field supply) require a dedicated power circuit for the booster heater. Please refer to the domestic hot water tank Installation & Owner's Manual. Secure the wiring in the order shown below.
- Lay out the electrical wiring so that the front cover does not rise up when doing wiring work and attach the front cover securely.
- Follow the electric wiring diagram for electrical wiring works (the electric wiring diagrams are located on the rear side of door 2).
- Install the wires and fix the cover firmly so that the cover may be fit in properly.

Signals / data lines

Do not overpass the maximum power allowed, which varies, according to the type of signal.

Lay the cables far from power cables or cables having a different tension and that are able to emit electromagnetic disturbances.

Do not lay the cable near devices which can generate electromagnetic interferences.

Do not lay the cables parallel to other cables; cable crossings are possible, only if laid at 90°.

Connect the screen to the ground, only if there aren't disturbances.

Guarantee the continuity of the screen during the entire extension of the cable.

Respect impedance, capacity and attenuation indications.

6 ELECTRICAL CONNECTIONS

Precautions on wiring of power supply

- Use a round crimp-style terminal for connection to the power supply terminal board. In case it cannot be used due to unavoidable reasons, be sure to observe the following instructions.
- Do not connect different gauge wires to the same power supply terminal. (Loose connections may cause overheating.)
- When connecting wires of the same gauge, connect them according to the figure below.

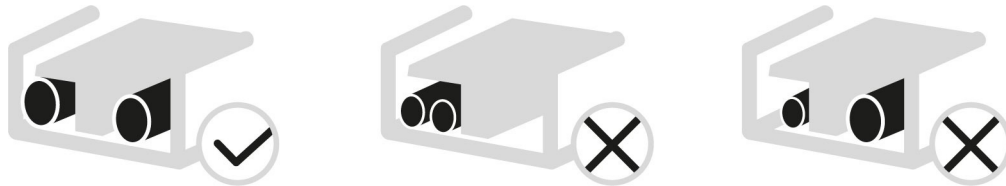

- Use the correct screwdriver to tighten the terminal screws. Small screwdrivers can damage the screw head and prevent appropriate tightening.
- Over-tightening the terminal screws can damage the screws.
- Attach a ground fault circuit interrupter and fuse to the power supply line.
- In wiring, make certain that prescribed wires are used, carry out complete connections, and fix the wires so that outside force cannot affect the terminals.

Specifications of standard wiring components

Door 1: compressor compartment and electrical parts: XT1

Unit (kW)	3-phase			
	18	22	26	30
Maximum overcurrent protector (MOP)	37.8	44.1	48.6	51.3
Wiring size (mm ²)	6	6	10	10

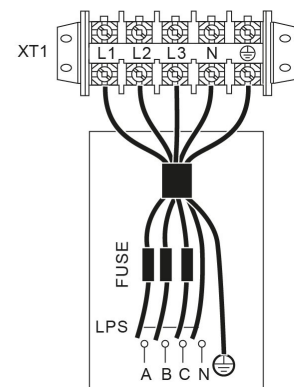

Stated values are maximum values (see electrical data for exact values).

NOTE

The ground fault circuit interrupter must be a high-speed type breaker of 30 mA (<0.1 s).

Procedure for all connections

- Connect the cable to the appropriate terminals as shown in the picture.
- Fix the cable with cable ties to the cable tie mountings to ensure stress relief.

6 ELECTRICAL CONNECTIONS

Connection terminal block

1	2	3	4	5	6	7	8	9	10	11	12		25	26	27	28		1	2	3	4	5	
SL1	SL2	H	C	1ON	1OFF	2ON	2OFF	P_c	P_o	P_s	P_d		HT	R2	ASH1	ASH2		A	B	X	Y	E	
	13	14	15	16	17	18	19	20	21	22	23	24		29	30	31	32		6	7	8	9	10
	TBH	IBH1	L1	N	N	N	3ON	3OFF	N	N	N	N		N	R1	DFT2	DFT1		P	Q	E	H1	H2

CN11

CN7

CN30

CN11			
1	1	SL1	Solar input
	2	SL2	
2	3	H	Room thermostat
	4	C	
	15	L1	
3	5	1ON	SV1 - 3-way valve
	6	1OFF	
	16	N	
4	7	2ON	SV2 - 3-way valve
	8	2OFF	
	17	N	
5	9	P_c	pump P_c (zone 2)
	21	N	
6	10	P_o	pump P-o (zone 1)
	22	N	
7	11	P_s	solar pump
	23	N	
8	12	P_d	HW PUMP
	24	N	
9	13	TBH	resistance TBH
	16	N	
10	14	IBH1	backup heater
	17	N	
11	18	N	SV3- 3-way valve
	19	3ON	
	20	3OFF	

CN11			
1	1	A	Wired Controller
	2	B	
	3	X	
	4	Y	
	5	E	
2	6	P	Outdoor unit
	7	Q	
3	9	H1	System parallel
	10	H2	

CN7			
1	26	R2	Unit signal in operation
	30	R1	
	31	DFT2	Defrosting prompt signal
	32	DFT1	
2	25	HT	Antifreeze resistance
	29	N	
3	27	AHS1	Additional heat source
	28	AHS2	

6 ELECTRICAL CONNECTIONS

Port provide the control signal to the load. Two kind of control signal port:

Type 1

Dry connector without voltage.

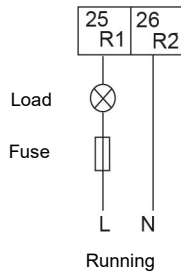

Type 2:

Port provide the signal with 220V voltage.

Cable section: 0,75 mm²

If the current of load is <0.2A, load can connect to the port directly.

If the current of load is >=0.2A, the AC connector is required to connected for the load.

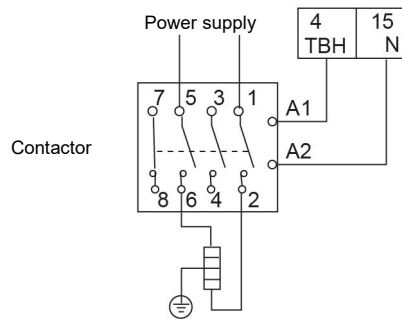

Operation signalling

Type 2

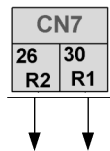

Antifreeze resistance

Type 2

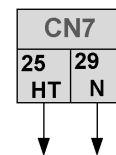
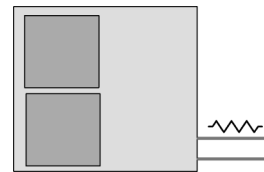

Defrosting signalling

Type 1

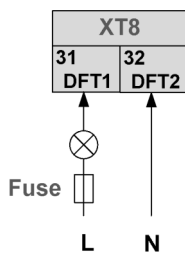

Domestic Hot Water (DHW)

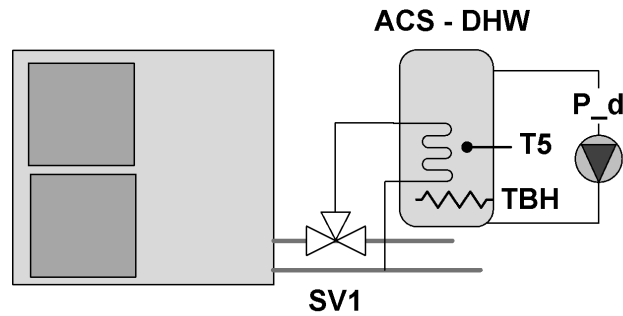

3-way valve SV1

Type 2

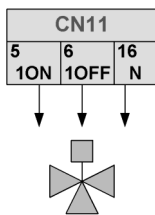

NOTE

Wiring of the 3-way valve is different for NC (normal close) and NO (normal open).
 Before wiring, read the Installation & Owner's manual for the 3-way valve carefully and install the valve as showed in the picture.
 Make sure to connect it to the correct terminal numbers.

Tank booster heater

Type 2

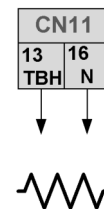

TBH tank boost heater

Connection of the booster heater cable depends on the application.

Only when the domestic hot water tank is installed will this wiring be needed.

The unit only sends a turn on/off signal to the booster heater.

An additional circuit breaker is needed and a dedicated terminal is needed to supply power to the booster heater.

Tank loop pump P_d

Type 2

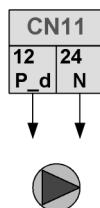

6 ELECTRICAL CONNECTIONS

2-zone system

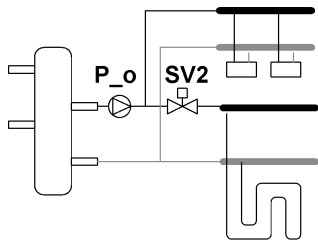

2-zone system mixed

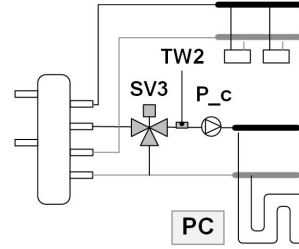

Outside circulation pump P_o

Type 2

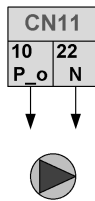

Mix pump P_c

Type 2

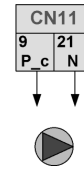

2-way valve SV2

Type 2

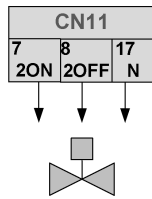

3-way valve SV3

Type 2

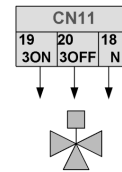

Thermostat

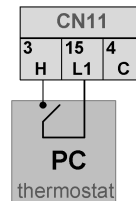

TW2 probe

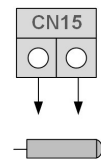

Condensate drain heating cable (performed by customer)

Electrical panel

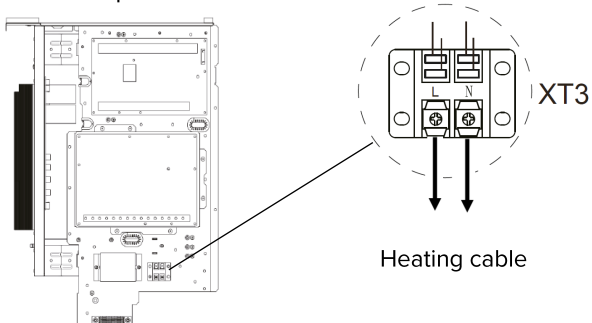

Maximum power 40W/200mA
Supply voltage 230V C.A.

6 ELECTRICAL CONNECTIONS

Additional heat source

Type 2

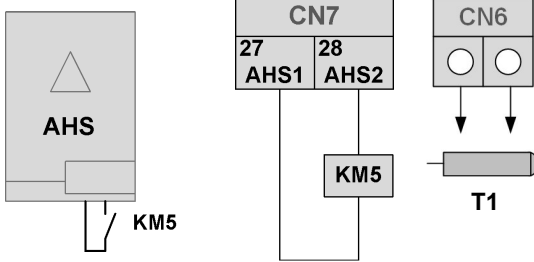

Solar kit

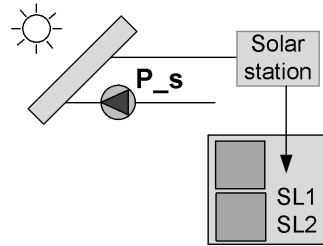

HEATING mode

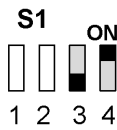

Pump solar P_s

Control from solar control unit

HEATING + DWH mode

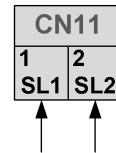
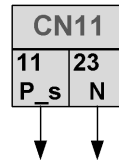
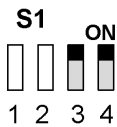

Solar station
230VAC

SMART GRID management - Photovoltaic

	EVU Photovoltaic signal	SG Smart grid
Unit is turned off.	OFF	OFF
Unit works normally	OFF	ON
Forced unit in DHW, even if it was off, with temperature increased to 70 °C	ON	ON
Forced unit in DHW	ON	OFF

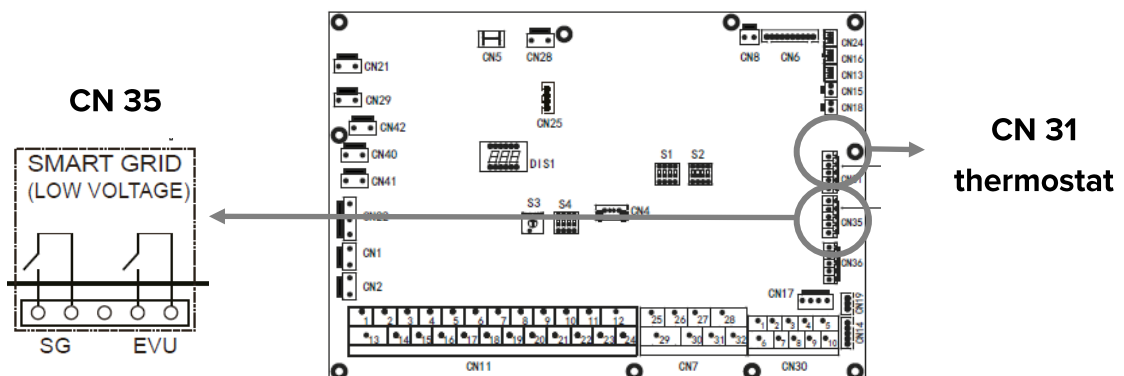

6 ELECTRICAL CONNECTIONS

User interface

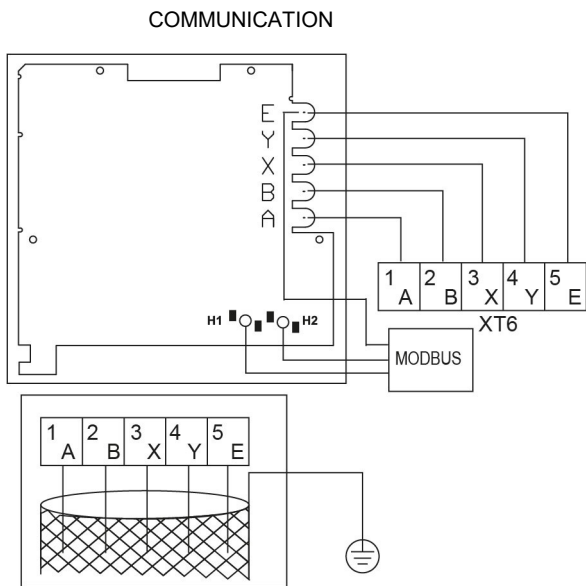

NOTE
 Use shielded wire and earth the wire.
 This equipment supports MODBUS RTU communication protocol. - See ATTACHMENTS

Wire type	5 wire shielded cable
Wire section (mm ²)	0.75~1.25
Maximum wire length (m)	50
Input voltage (A/B)	13.5VAC

Installation

- Do not install the unit in a place with much oil, steam, sulfide gas. Otherwise, the product may deform and fail.
- 2) Check that all the components listed below are present.
 - 3) Circuit of Wired Remote Controller is low voltage circuit. Never connect it with a standard 220V/380V circuit or put it into a same Wiring Tube with the circuit.
 - 4) The shielded cable must be connected stable to the ground, or transmission may fail.
 - 5) Do not attempt to extend the shielded cable by cutting, if it is necessary, use Terminal Connection Block to connect.
 - 6) After finishing connection, do not use Megger to have the insulation check for the signal wire

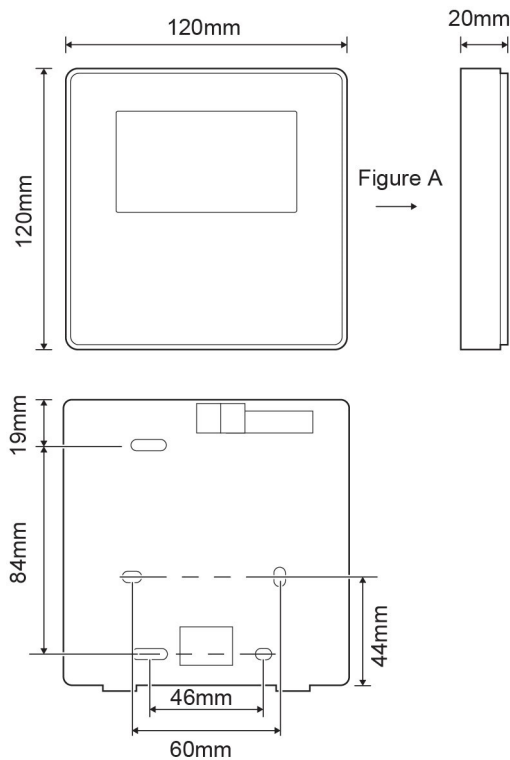

No.	Name	Qty.	Remarks
1	Wired Controller	1	
2	Cross round head wood mounting screw	3	For Mounting on the Wall
3	Cross round head mounting screw	2	For Mounting on the Electrical Switch Box
4	Installation and Owner's Manual	1	
5	Plastic bolt	2	This accessory is used when install the centralized control inside the electric cabinet
6	Plastic expansion pipe	3	For mounting on the Wall

Back cover installation

- 1) Use straight head screwdriver to insert in the buckling position in the bottom of wired controller, and spin the screwdriver to take down the back cover. (Pay attention to spinning direction, otherwise will damage the back cover!)
- 2) Use three M4X20 screws to directly install the back cover on the wall.
- 3) Use two M4X25 screws to install the back cover on the 86 electrician box, and use one M4X20 screws for fixing on the wall.
- 4) Adjust the length of two plastic screw bars in the accessory to be standard length from the electrical box screw bar to the wall. Make sure while installing the screw bar to the wall, making it as flat as the wall.
- 5) Use cross head screws to fix the wired controller bottom cover in the wall through the screw bar. Make sure the wired controller bottom cover is on the same level after installation, and then install the wired controller back to the bottom cover.
- 6) Over fastening the screw will lead to deformation of back cover.

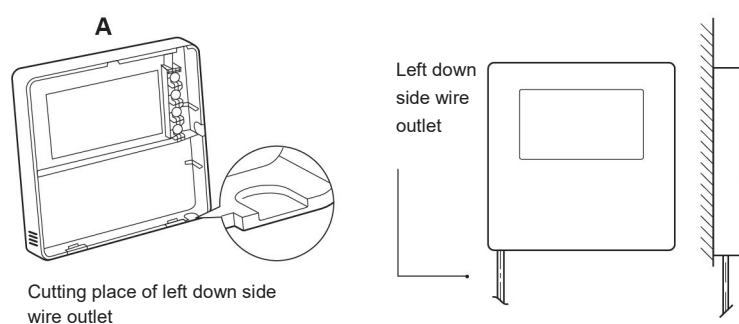

Wall installation

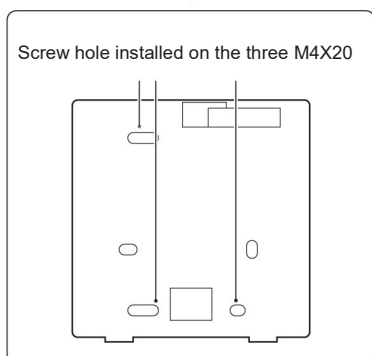
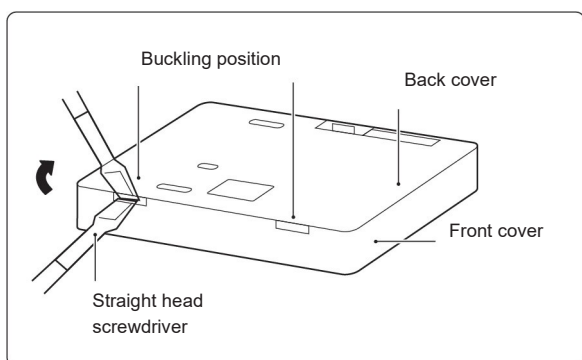

Installation in electrical box 86

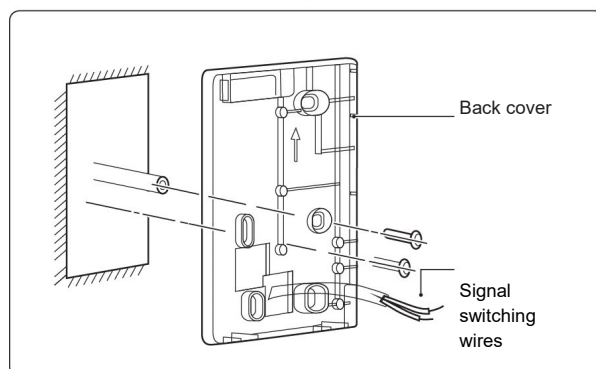
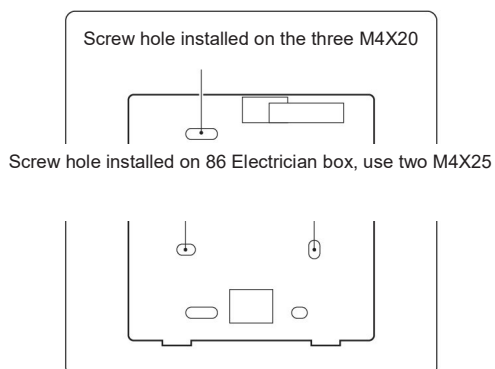

6 ELECTRICAL CONNECTIONS

Avoid the water enter into the wired remote controller, use trap and putty to seal the connectors of wires during wiring installation.

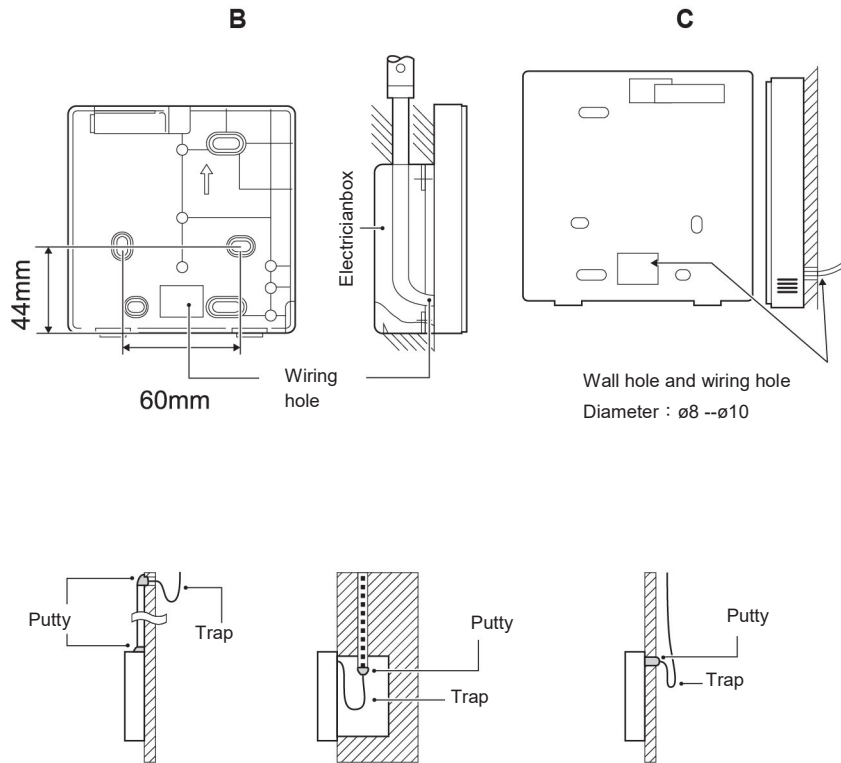

Front cover installation

After adjusting the front cover and then buckle the front cover; avoid clamping the communication switching wire during installation.

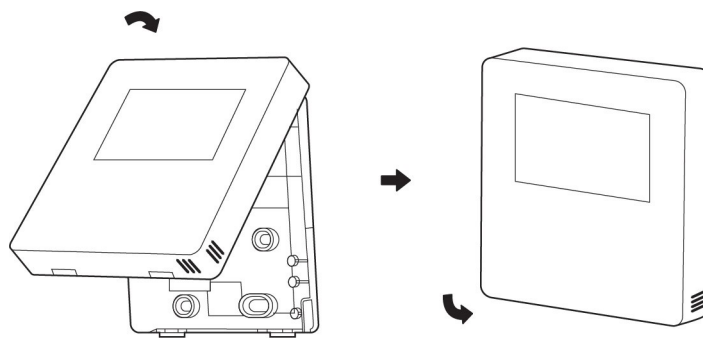

Sensor can not be affected with damp.

Correct install the back cover and firmly buckle the front cover and back cover, otherwise will make the front cover drop off.

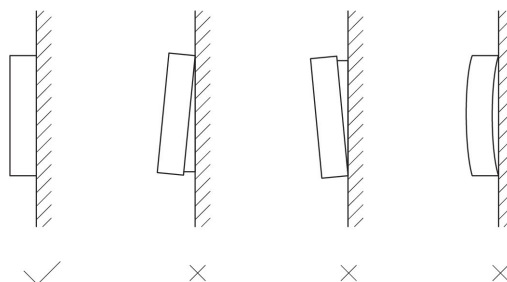

Room thermostat - Not supplied

There are three methods for connecting the thermostat cable and it depends on the application.

Method A

- On-Off + Heat from input H - L1
- On-Off + Cool from input C - L1

User interface setting:

ROOM THERMOSTAT and ROOM THERMOSTAT to MODE SET

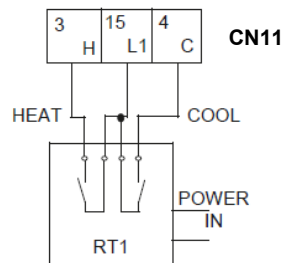

Method B

- On-Off from input H - L1
- Heat-Cool from user interface

User interface setting:

ROOM THERMOSTAT and ROOM THERMOSTAT to ONE ZONE,

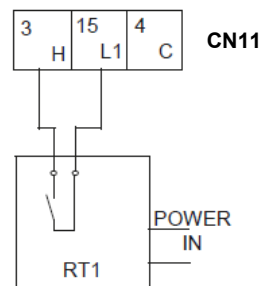

NOTE

When ROOM THERMOSTAT is set , the indoor temperature sensor Ta can't be set to valid, unit running only according to T1.

Method C

Hydraulic module is connected with two external temperature..

- On-Off zone 1 from input H - L1
- On-Off zone 1 from input C - L1
- Heat-Cool from user interface

User interface setting:

ROOM THERMOSTAT and ROOM THERMOSTAT to DOUBLE ZONE

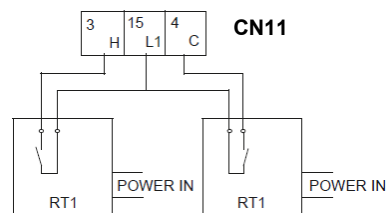

NOTE

The wiring of the thermostat should correspond to the settings of the user interface.

See chapter START-UP AND CONFIGURATION - ROOM THERMOSTAT.

Power supply of machine and room thermostat must be connected to the same Neutral Line and (L2) Phase Line(for 3-phase unit only).

7 START-UP AND CONFIGURATION

The unit should be configured by the installer to match the installation environment (outdoor climate, installed options, etc.) and user expertise.

CAUTION

It is important that all information in this chapter is read sequentially by the installer and that the system is configured as applicable.

Description of terms

The terms related to this unit are shown in the table below.

Parameter	Description
AHS	Additional heating source
DHW	Domestic hot water
IBH1	The first backup heater
IBH2	The second backup heater
Pe	Evaporate/condense pressure in cooling/ heating mode
T1	Water outlet temperature from the additional heat source (backup heater or boiler)
TW2	Mixed circuit temperature
T1S	Setpoint per la temperatura di uscita dell'acqua
T2	Temperature of refrigerant at let outlet /inlet of plate heat exchanger when in heating mode/ cooling mode
T2B	Temperature of refrigerant at let outlet /inlet of plate heat exchanger when in heating mode/ cooling mode
T3	Temperature of tube at outlet/inlet of condenser when in cooling/heating mode
T4	Ambient temperature
T5	Temperature of domestic hot water
Th	Suction temperature
Tp	Discharge temperature
TW_in	Inlet water temperature of plate heat exchanger
TW_out	Outlet water temperature of plate heat exchanger
TBH	Backup heater in the domestic hot water tank

Climate related curves

The Climate related curves can be selected in the user interface.

Once the curve is selected, the target outlet temperature. In each mode, user can select one curve from curves in the user interface (curve can't be selected if dual room thermostat function is enabled).

It's possible to select curves even dual room thermostat function is enabled. This function is for customized.

The relationship between outdoor temperature ($T4/^{\circ}\text{C}$) and the target water temperature ($T1S/^{\circ}\text{C}$) is described in the table and picture in the next page.)

NOTE

If dual room thermostat function is enabled, only curve 4 can be used, for customization product, curve selection is possible even dual room thermostat function is enabled.

7 START-UP AND CONFIGURATION

Temperature curves 18-30 kW

Heating mode and ECO heating mode - Low temperature curves

T4	≤-20	-19	-18	-17	-16	-15	-14	-13	-12	-11	-10	-9	-8	-7	-6	-5	-4	-3	-2	-1	0
1-T1S	38	38	38	38	38	37	37	37	37	37	37	36	36	36	36	36	36	35	35	35	35
2-T1S	37	37	37	37	37	36	36	36	36	36	36	35	35	35	35	35	35	34	34	34	34
3-T1S	36	36	36	35	35	35	35	35	35	34	34	34	34	34	34	33	33	33	33	33	33
4-T1S	35	35	35	34	34	34	34	34	34	33	33	33	33	33	33	32	32	32	32	32	32
5-T1S	34	34	34	33	33	33	33	33	33	32	32	32	32	32	32	31	31	31	31	31	31
6-T1S	32	32	32	32	31	31	31	31	31	31	31	31	30	30	30	30	30	30	30	30	29
7-T1S	31	31	31	31	30	30	30	30	30	30	30	30	29	29	29	29	29	29	29	29	28
8-T1S	29	29	29	29	28	28	28	28	28	28	28	28	27	27	27	27	27	27	27	27	26
T4	1	2	3	4	5	6	7	8	9	10	11	12	13	14	15	16	17	18	19	≥20	
1-T1S	35	35	34	34	34	34	34	34	33	33	33	33	33	33	32	32	32	32	32	32	32
2-T1S	34	34	33	33	33	33	33	33	32	32	32	32	32	32	31	31	31	31	31	31	31
3-T1S	32	32	32	32	32	32	31	31	31	31	31	31	30	30	30	30	30	30	29	29	29
4-T1S	31	31	31	31	31	31	30	30	30	30	30	30	29	29	29	29	29	29	28	28	28
5-T1S	30	30	30	30	30	30	29	29	29	29	29	29	28	28	28	28	28	28	27	27	27
6-T1S	29	29	29	29	29	29	28	28	28	28	28	28	27	27	27	27	27	27	26	26	26
7-T1S	28	28	28	28	28	28	27	27	27	27	27	27	26	26	26	26	26	26	25	25	25
8-T1S	26	26	26	26	26	26	26	25	25	25	25	25	25	25	25	24	24	24	24	24	24

T4: Outdoor Temperatures

T1S: set water temperature

Heating mode and ECO heating mode - High temperature curves

T4	≤-20	-19	-18	-17	-16	-15	-14	-13	-12	-11	-10	-9	-8	-7	-6	-5	-4	-3	-2	-1	0
1-T1S	55	55	55	55	54	54	54	54	54	54	54	54	53	53	53	53	53	53	53	53	52
2-T1S	53	53	53	53	52	52	52	52	52	52	52	52	51	51	51	51	51	51	51	51	50
3-T1S	52	52	52	52	51	51	51	51	51	51	51	51	50	50	50	50	50	50	50	50	49
4-T1S	50	50	50	50	49	49	49	49	49	49	49	49	48	48	48	48	48	48	48	48	47
5-T1S	48	48	48	48	47	47	47	47	47	47	47	47	46	46	46	46	46	46	46	46	45
6-T1S	45	45	45	45	44	44	44	44	44	44	44	44	43	43	43	43	43	43	43	43	42
7-T1S	43	43	43	43	42	42	42	42	42	42	42	42	41	41	41	41	41	41	41	41	40
8-T1S	40	40	40	40	39	39	39	39	39	39	39	39	38	38	38	38	38	38	38	38	37
T4	1	2	3	4	5	6	7	8	9	10	11	12	13	14	15	16	17	18	19	≥20	
1-T1S	52	52	52	52	52	52	52	51	51	51	51	51	51	51	51	50	50	50	50	50	50
2-T1S	50	50	50	50	50	50	50	49	49	49	49	49	49	49	49	48	48	48	48	48	48
3-T1S	49	49	49	49	49	49	49	48	48	48	48	48	48	48	48	47	47	47	47	47	47
4-T1S	47	47	47	47	47	47	47	46	46	46	46	46	46	46	46	45	45	45	45	45	45
5-T1S	45	45	45	45	45	45	45	44	44	44	44	44	44	44	44	43	43	43	43	43	43
6-T1S	42	42	42	42	42	42	42	41	41	41	41	41	41	41	41	40	40	40	40	40	40
7-T1S	40	40	40	40	40	40	40	39	39	39	39	39	39	39	39	38	38	38	38	38	38
8-T1S	37	37	37	37	37	37	37	36	36	36	36	36	36	36	36	35	35	35	35	35	35

Automatic curve HEATING mode

It is curve number 9.

It can be set as shown in the figure.

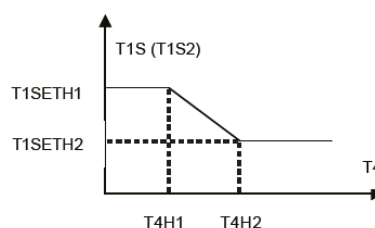

7 START-UP AND CONFIGURATION

COOLING mode - Low temperature curves

T4	$-10 \leq T4 < 15$	$15 \leq T4 < 22$	$22 \leq T4 < 30$	$30 \leq T4$
1-T1S	16	11	8	5
2-T1S	17	12	9	6
3-T1S	18	13	10	7
4-T1S	19	14	11	8
5-T1S	20	15	12	9
6-T1S	21	16	13	10
7-T1S	22	17	14	11
8-T1S	23	18	15	12

T4: Outdoor Temperatures

T1S: set water temperature

COOLING mode - High temperature curves

T4	$-10 \leq T4 < 15$	$15 \leq T4 < 22$	$22 \leq T4 < 30$	$30 \leq T4$
1-T1S	20	18	17	16
2-T1S	21	19	18	17
3-T1S	22	20	19	17
4-T1S	23	21	19	18
5-T1S	24	21	20	18
6-T1S	24	22	20	19
7-T1S	25	22	21	19
8-T1S	25	23	21	20

Automatic curve COOLING mode

It is curve number 9.

It can be set as shown in the figure.

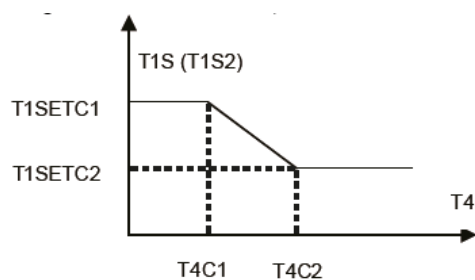

DIP switch settings overview - Function setting

WARNING

Switch off the power supply before opening the switch box service panel and making any changes to the DIP switch settings. Work on the DIP switches with an insulated screwdriver, in order to avoid electrostatic discharges.

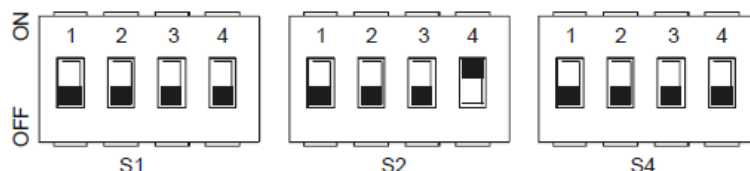

DIP switch		ON = 1	OFF = 0	Factory configuration
S1	1	Reserved	Reserved	Refer to the unit electrical diagram (the number of the diagram is shown on the serial number label).
	2	Reserved	Reserved	
	3 / 4	0/0 = IBH and AHS not present 0/1 = IBH present 1/0 = AHS present (heating mode) 1/1 = AHS present (heating and DHW)		

AHS additional heating source

IBH external backup heater (optional)

DIP switch		ON = 1	OFF = 0	Factory configuration
S2	1	Pump P _o does NOT activate every 24 hours	Pump P _o activates every 24 hours	Refer to the unit electrical diagram (the number of the diagram is shown on the serial number label).
	2	TBH not present	TBH present	
	3 / 4	0/0 = variable speed pump (max 8.5mt) 0/1 = fixed speed pump 1/0 = variable speed pump (max 10.5mt) 1/1 = variable speed pump (max 9mt)		

TBH Storage tank electric heater

P_o external pump

DIP switch		ON = 1	OFF = 0	Factory configuration
S4	1	Master unit:clear address of all slave units Slave unit:clear its own address	Keep the current address	Refer to the unit electrical diagram (the number of the diagram is shown on the serial number label).
	2	Reserved	Reserved	
	3 / 4	Reserved		

7 START-UP AND CONFIGURATION

Maximum operating current setting

On the wired control, access the menu:

FOR SERVICEMAN - POWER INPUT LIMITATION

Initial start-up at low outdoor ambient temperatures

During initial start-up and when water temperature is low, it is important that the water is heated gradually. Failure to do so may result in concrete floors cracking due to rapid temperature change. Please contact the responsible cast concrete building contractor for further details.

To do so, the lowest water flow set temperature can be decreased to a value between 25°C and 35°C by adjusting the FOR SERVICEMAN - SPECIAL FUNCTION - PREHEATING FOR FLOOR

Pre-operation checks

Checks before initial start-up.

DANGER

Switch off the power supply before making any connections.

After the installation of the unit, check the following before switching on the circuit breaker:

- **Field wiring :**
Make sure that the field wiring between the local supply panel and unit and valves (when applicable), unit and room thermostat (when applicable), unit and domestic hot water tank, and unit and backup heater kit have been connected according to the instructions described in the chapter Electrical connections, according to the wiring diagrams and to local laws and regulations.
- **Fuses, circuit breakers, or protection devices:**
Check that the fuses or the locally installed protection devices are of the size and type specified in the page 56,57 on the chapter Electrical connections.
Make sure that no fuses or protection devices have been bypassed.
- **Backup heater circuit breaker :**
Do not forget to turn on the backup heater circuit breaker in the switchbox (it depends on the backup heater type).
Refer to the wiring diagram.
- **Booster heater circuit breaker :** Do not forget to turn on the booster heater circuit breaker (applies only to units with optional domestic hot water tank installed).
- **Ground wiring :**
Make sure that the ground wires have been connected properly and that the ground terminals are tightened.
- **Internal wiring :**
Visually check the switch box for loose connections or damaged electrical components.
- **Mounting :**
Check that the unit is properly mounted, to avoid abnormal noises and vibrations when starting up the unit.
- **Damaged equipment :**
Check the inside of the unit for damaged components or squeezed pipes.
- **Refrigerant leak :**
Check the inside of the unit for refrigerant leakage. If there is a refrigerant leak, call your local dealer.
- **Power supply voltage :**
Check the power supply voltage on the local supply panel.
The voltage must correspond to the voltage on the identification label of the unit.
- **Air purge valve :**
Make sure the air purge valve is open (at least 2 turns).
- **Shut-off valves :**
Make sure that the shut-off valves are fully open.

Powering up the unit

When power to the unit is turned on, "1%~99%" is displayed on the user interface during initialization. During this process the user interface cannot be operated.

Setting the pump speed

The pump speed can be selected by adjusting the red knob on the pump.

The notch point indicates pump speed.

The default setting is the highest speed (III).

If the water flow in the system is too high the speed can be set to low (I).

The available external static pressure function for water flow is shown in the graph below.

DANGER

Operating the system with closed valves will damage the circulation pump!

Available external static pressure VS flowrate

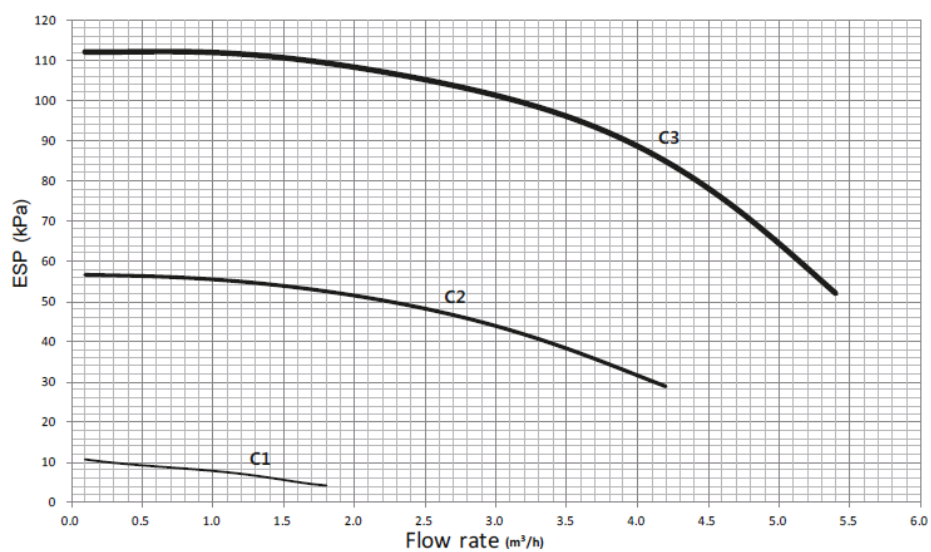
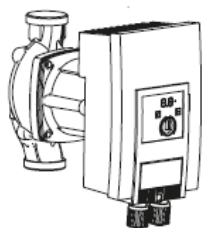

DANGER

If it's necessary to check the running status of the pump when unit power on.

Please do not touch the internal electronic control box components to avoid electric shock.

7 START-UP AND CONFIGURATION

Pump LED diagnosis

Cod	Pump status	Description	Cause	Remendy
E04	OFF	Mains undervoltage	Power supply too low on mains side	Check mains voltage.
E05	OFF	Mains overvoltage	Power supply too high on mains side	Check mains voltage.
E07	ON	Generator operation	Pump hydraulics have fluid running through them.	Check the system
E09	OFF	Turbine operation	The pump is driven in reverse	Check flow, install non-return valves if necessary
E10	OFF	Blocking	The rotor is blocked	Request customer service
E11	ON	Dry running	Air in the pump	Check system charge (pressure and volume)
E21	ON	Overload	Sluggish motor	Request customer service
E23	OFF	Short-circuit	Motor current too high	Request customer service
E25	OFF	Contacting/winding	Defective	Request customer service
E30	OFF	Module overheated		Check operating conditions
E31	OFF	Overheated power section	Ambient temperature too high	Check operating conditions
E36	OFF	Electronic faults		Request customer service

7 START-UP AND CONFIGURATION

The unit shall be configured by the installer to match the installation environment (outdoor climate, installed options, etc.) and user demand.

A number of field settings are available. These settings are accessible and programmable through "FOR SERVICEMAN" in user interface.

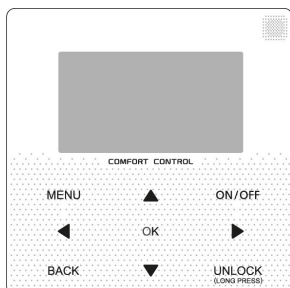

Keys	Function
MENU	Go to the menu structure(on the home page)
LEFT RIGHT UP DOWN	Navigate the cursor on the display Navigate in the menu structure Adjust settings
ON/OFF	Turn on/off the space heating/cooling operation or DHW mode Turn on/or off functions in the menu structure
BACK	Come back to the up level
UNLOCK	Long press for unlock /lock the controller Unlock /lock some functions such as "DHW temperature adjusting "
OK	Go to the next step when programming a schedule in the menu structure; and confirm a selection to enter in the submenu of the menu structure.

FOR SERVICEMAN

FOR SERVICEMAN is designed for the installer to set the parameter.

- Setting the composition of equipment.
- Setting the parameter.

How to go to FOR SERVICEMAN

Go to MENU> FOR SERVICEMAN.

Press OK

Use LEFT RIGHT UP DOWN to navigate and to adjust the numerical value.

Press OK.

The password is 234.

Use UP DOWN to scroll and use "ok" to enter submenu for setting the parameters.

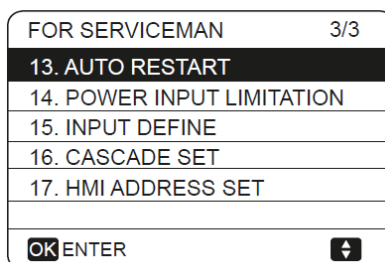
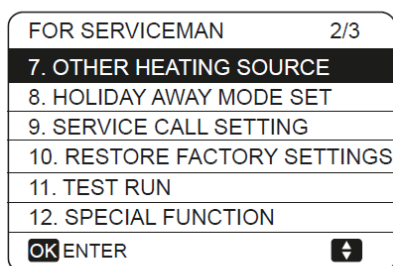
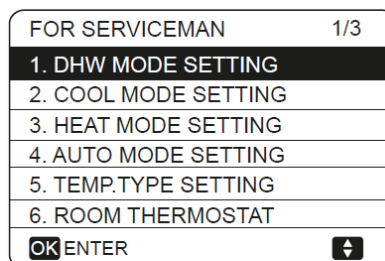

NOTE

The parameters relating to the functions reserved for technicians are shown at the end of the chapter.

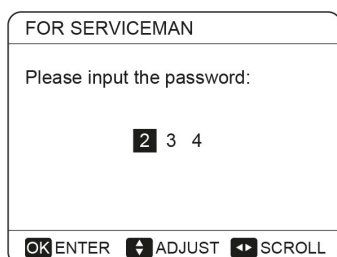

7 START-UP AND CONFIGURATION

DHW mode

How to set the DHW mode

To determine whether the DHW mode is effective.
Go to MENU> FOR SERVICEMAN> DHW MODE SETTING. Press OK. The following page is displayed:

1 DHW MODE SETTING	1/5
1.1 DHW MODE	YES
1.2 DISINFECT	YES
1.3 DHW PRIORITY	YES
1.4 DHW PUMP	YES
1.5 DHW PRIORITY TIME SET	NON
ADJUST	

1 DHW MODE SETTING	2/5
1.6 dT5_ON	5 °C
1.7 dT1S5	10 °C
1.8 T4DHWMAX	43 °C
1.9 T4DHWMIN	-10 °C
1.10 t_INTERVAL_DHW	5 MIN
ADJUST	

1 DHW MODE SETTING	3/5
1.11 dT5_TBH_OFF	5 °C
1.12 T4_TBH_ON	5 °C
1.13 t_TBH_DELAY	30 MIN
1.14 T5S_DI	65 °C
1.15 t_DI HIGHTEMP.	15MIN
ADJUST	

1 DHW MODE SETTING	4/5
1.16 t_DI_MAX	210 MIN
1.17 t_DHWHP_RESTRICT	30 MIN
1.18 t_DHWHP_MAX	120 MIN
1.19 DHWPUMP TIME RUN	YES
1.20 PUMP RUNNING TIME	5 MIN
ADJUST	

1 DHW MODE SETTING	5/5
1.21 DHW PUMP DI RUN	NON
ADJUST	

Cooling mode setting

How to set the Cooling mode

To determine whether the COOLING mode is effective, go to MENU> FOR SERVICEMAN> COOL MODE SETTING. Press OK.

The following page will be displayed:

2 COOL MODE SETTING	1/3
2.1 COOL MODE	YES
2.2 t_T4_FRESH_C	2.0HRS
2.3 T4CMAX	43 °C
2.4 T4CMIN	20 °C
2.5 dT1SC	5 °C
ADJUST	

2 COOL MODE SETTING	2/3
2.6 dTSC	2 °C
2.7 t_INTERVAL_C	5MIN
2.8 T1SetC1	10 °C
2.9 T1SetC2	16 °C
2.10 T4C1	35 °C
ADJUST	

2 COOL MODE SETTING	3/3
2.11 T4C2	25 °C
2.12 ZONE1 C-EMISSION	FCU
2.13 ZONE2 C-EMISSION	FLH
ADJUST	

Heating mode

How to set the Heat mode

To determine whether the HEAT mode is effective, go to MENU > FOR SERVICEMAN > HEAT MODE SETTING. Press OK.

The following page be displayed:

3 HEAT MODE SETTING	1/3
3.1 HEAT MODE	YES
3.2 t_T4_FRESH_H	2.0HRS
3.3 T4HMAX	16 °C
3.4 T4HMIN	-15 °C
3.5 dT1SH	5 °C
ADJUST	

3 HEAT MODE SETTING	2/3
3.6 dTSH	2 °C
3.7 t_INTERVAL_H	5MIN
3.8 T1SetH1	35 °C
3.9 T1SetH2	28 °C
3.10 T4H1	-5 °C
ADJUST	

3 HEAT MODE SETTING	3/3
3.11 T4H2	7 °C
3.12 ZONE1 H-EMISSION	RAD.
3.13 ZONE2 H-EMISSION	FLH
3.14 t_DELAY_PUMP	2MIN
ADJUST	

7 START-UP AND CONFIGURATION

Auto mode

How to set the AUTO mode

To determine whether the AUTO mode is effective, go to MENU > FOR SERVICEMAN > AUTO MODE SETTING.

Press OK.

The following page is displayed.

4 AUTO. MODE SETTING	
4.1 T4AUTOCMIN	25°C
4.2 T4AUTOHMAX	17°C
← ADJUST	▶

Temperature type setting

The TEMP. TYPE SETTING is used for selecting whether the water flow temperature or room temperature (detected by the temperature sensor attached in the user interface) is used to control the ON/OFF of the heat pump.

When ROOM TEMP. is enabled, the target outlet water temperature will be calculated from climate-related curves (see chapter Start-up and configuration -Climate related curves").

How to enter the temperature

To enter the TEMP. TYPE SETTING, go to MENU > FOR SERVICEMAN > TEMP. TYPE SETTING.

Press OK.

The following page is displayed:

5 TEMP. TYPE SETTING	
5.1 WATER FLOW TEMP.	YES
5.2 ROOM TEMP.	NON
5.3 DOUBLE ZONE	NON
← ADJUST	▶

Only WATER FLOW TEMP = YES

01-01-2018	23:59	13°
⌵	ON	⌵
Δ 23 °C	☀	38 °C

Only ROOM TEMP = YES

01-01-2018	23:59	13°
⌵	ON	⌵
23.5 °C	☀	38

WATER FLOW TEMP = YES + ROOM TEMP = YES

Zone 1 Zone 2

01-01-2018	23:59	13°	01-01-2018	23:59	13°
⌵	ON	⌵	⌵ ₂	ON	☀
Δ 23 °C	☀	38 °C	23.5 °C	☀	☀

In this case the setpoint for zone 1 is T1S, the setpoint for zone 2 is TS (TIS2 is calculated in accordance with the climatic curve).

DOUBLE ZONE = YES + ROOM TEMP = NO

Zona 1 Zona 2

01-01-2018	23:59	13°	01-01-2018	23:59	13°
⌵	ON	⌵	⌵ ₂	ON	☀
Δ 23 °C	☀	38 °C	Δ 23 °C	☀	☀

DOUBLE ZONE = YES + ROOM TEMP = YES

Zone 1 Zone 2

01-01-2018	23:59	13°	01-01-2018	23:59	13°
⌵	ON	⌵	⌵ ₂	ON	☀
Δ 23 °C	☀	38 °C	23.5 °C	☀	☀

In this case the setpoint for zone 1 is T1S, the setpoint for zone 2 is TS (TIS2 is calculated in accordance with the climatic curve).

7 START-UP AND CONFIGURATION

Room thermostat

About room thermostat

The ROOM THERMOSTAT is used to set whether the room thermostat is available.

How to set the room thermostat

To set the ROOM THERMOSTAT, go to MENU > FOR SERVICEMAN > ROOM THERMOSTAT.

Press OK.

The following page is displayed:

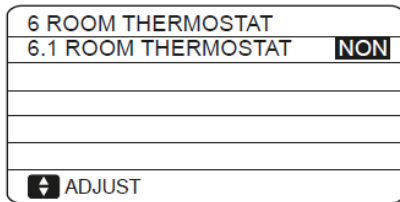

NOTE

The setting in the user interface should correspond to the wiring of thermostat.

If ROOM THERMOSTAT = MODE SET, the wiring of thermostat should follow method A.

If ROOM THERMOSTAT = ONE ZONE, the wiring of thermostat should follow method B.

If ROOM THERMOSTAT = DOUBLE ZONE, the wiring of thermostat should follow method C.

See chapter Electrical connections - Thermostat")

Other heating source

The OTHER HEATING SOURCE is used to set whether the backup heater, and additional heating sources like a boiler or solar energy kit is available.

Configuration

To set the OTHER HEATING SOURCE, go to MENU > FOR SERVICEMAN > OTHER HEATING SOURCE.

Press OK.

The following page will appear:

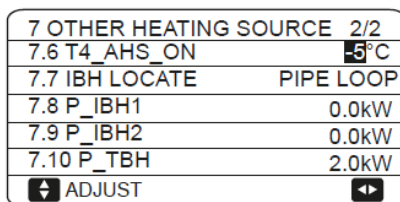
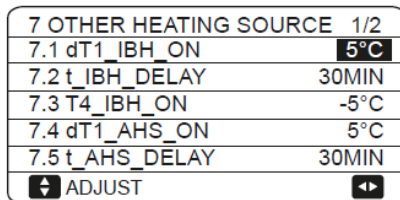

HOLIDAY AWAY setting

About setting

The HOLIDAY AWAY SETTING is used to set the outlet water temperature to prevent freezing when away for holiday..

How to enter the setting

To enter the HOLIDAY AWAY SETTING, go to MENU > FOR SERVICEMAN > HOLIDAY AWAY SETTING.

Press OK.

The following page is displayed:

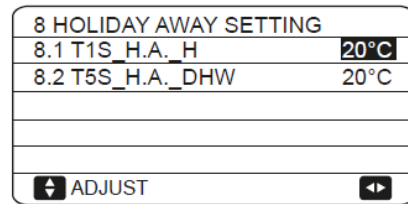

Service call setting

The installers can set the phone number of the local dealer in SERVICE CALL.

If the unit doesn't work properly, call this number for help.

Configuration

To set the SERVICE CALL, go to MENU > FOR SERVICEMAN > SERVICE CALL. Press OK.

The following page is displayed:

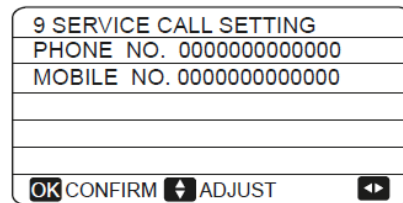

Use UP DOWN to scroll and set the phone number.

The maximum length of the phone number is 13 digits, if the length of phone number is short than 12, please input *, as shown below:

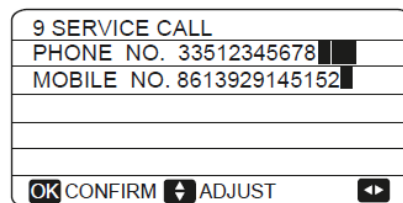

The number displayed on the user interface is the phone number of your local dealer.

7 START-UP AND CONFIGURATION

Restore factory settings

The RESTORE FACTORY SETTING is used to restore all the parameters set in the user interface to the factory setting.

To restore factory settings, go to MENU > FOR SERVICEMAN > RESTORE FACTORY SETTINGS.

Press OK.

The following page is displayed:

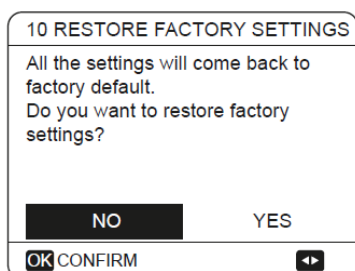

Use LEFT RIGHT to scroll the cursor to YES and press OK.

The following page will be displayed:

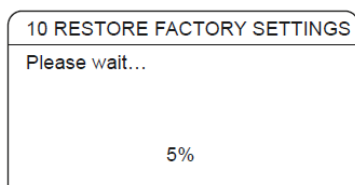

After a few seconds, all the parameters set in the user interface will be restored to factory settings.

Test run

TEST RUN is used to check correct operation of the valves, air purge, circulation pump operation, cooling, heating and domestic water heating.

How to enter test run

To enter test run, go to MENU > FOR SERVICEMAN > TEST RUN.

Press OK.

The following page is displayed:

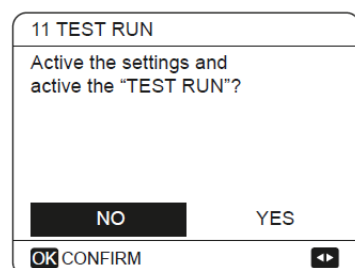

If YES is selected, the following page is displayed:

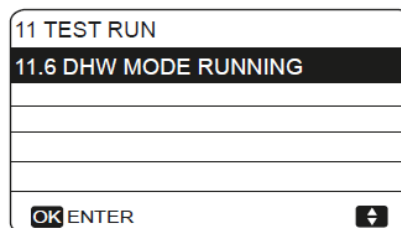
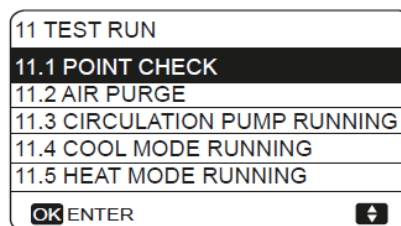

Use UP DOWN to scroll to the mode you want to run and press OK.

The unit will run as selected.

If POINT CHECK is selected, the following page will appear:

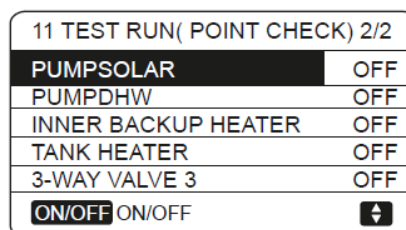
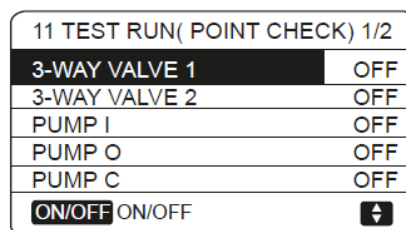

Use UP DOWN to scroll to the components you want to check and press ON/OFF. For example, when 3-WAY VALVE is selected and ON/OFF is pressed, if the 3-way valve is open/close, then the operation of 3-way valve is normal, and so are other components.

NOTE

Before the test run, make sure that the system is filled and vented.

Otherwise the pump and the backup resistor can be damaged.

7 START-UP AND CONFIGURATION

If you select AIR PURGE :

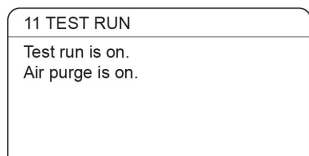

When in air purge mode, the 3-way valve will open, the 2-way valve will close.

60s later the pump in the unit (PUMPI) will operate for 10min during which the flow switch will not work.

After the pump stops, the 3-way valve will close and the 2-way valve will open.

60s later both the PUMPI and PUMPO will operate until the next command is received.

When CIRCULATION PUMP RUNNING is selected, the page will displayed as follows:

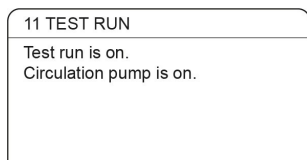

When CIRCULATION PUMP RUNNING is turned on, all running components will stop.

60 minutes later, the 3-way valve will open, the 2-way valve will close, 60 seconds later PUMPI will operate.

30s later, if the flow switch checked normal flow, PUMPI will operate for 3min, after the pump stops, the 3-way valve will close and the 2-way valve will open.

60s later the both PUMPI and PUMPO will operate, 2 mins later, the flow switch will check the water flow.

If the flow switch closes for 15s, PUMPI and PUMPO will operate until the next command is received.

When the COOL MODE RUNNING is selected, the page will displayed as follows:

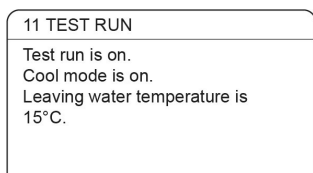

During COOL MODE test running, the default target outlet water temperature is 7°C.

The unit will operate until the water temperature drops to a certain value or the next command is received.

When the HEAT MODE RUNNING is selected, the page will displayed as follows:

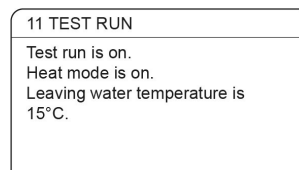

During HEAT MODE test running, the default target outlet water temperature is 35°C.

The first backup heater will turn on after the compressor runs for 10 min, 60s later the second backup heater will turn on.

After the two backup heater runs for 3 min, both backup heaters will turn off, the heat pump will operate until the water temperature increase to a certain value or the next command is received.

When the DHW MODE RUNNING is selected, the page will displayed as follows:

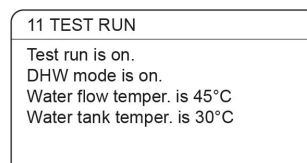

During DHW MODE test running, the default target temperature of the domestic water is 55°C.

The booster heater will turn on after the compressor runs for 10min.

The booster heater will turn off 3 min later, the heat pump will operate until the water temperature increase to a certain value or the next command is received.

During test run, all buttons except OK are invalid.

If you want to turn off the test run, please press OK.

For example ,when the unit is in air purge mode, after you press OK, the page will displayed as follows:

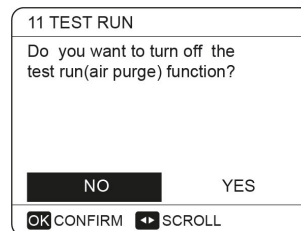

Use LEFT RIGHT to scroll the cursor to YES and press OK. The test run will turn off.

7 START-UP AND CONFIGURATION

Special functions

When special functions are active, the wired controller cannot operate, it is not possible to return to the homepage and the screen shows the page where the specific function is running.

NOTE

The special functions can be used by service man only, during special function operating other functions (SCHEDULE , HOLIDAY AWAY, HOLIDAY HOME) can't be used.

Go to MENU> FOR SERVICEMAN> SPECIAL FUNCTION. Before activating the underfloor heating, it is necessary to gradually heat it to remove the water contained, otherwise there is a risk of breakage.

12 SPECIAL FUNCTION	
Active the settings and active the "SPECIAL FUNCTION"?	
NO	YES
OK CONFIRM	▶

12 SPECIAL FUNCTION	
12.1 PREHEATING FOR FLOOR	
12.2 FLOOR DRYING UP	
OK ENTER	▶

Use LEFT RIGHT to scroll and use OK to confirm. If PREHEATING FOR FLOOR is selected, after press OK ,the page will displayed as follows:

12.1 PREHEATING FOR FLOOR	
T1S	30°C
t_fristFH	72 HOURS
ENTER	EXIT
ADJUST	▶

When the cursor is on OPERATE PREHEATING FOR FLOOR, use LEFT RIGHT to scroll to YES and press OK. The page will be displayed as follows:

12.2 PREHEATING FOR FLOOR
Preheat for floor is running for 25 minutes. Water flow temperature is 20°C.

During preheating for floor, all the buttons except OK are invalid.

If you want to turn off the preheating for floor, please press OK. The following page will be displayed:

12.2 PREHEATING FOR FLOOR	
Do you want to turn off the preheating for floor function?	
NO	YES
OK CONFIRM	▶ SCROLL

The operation of the unit during preheating for floor described in the picture below:

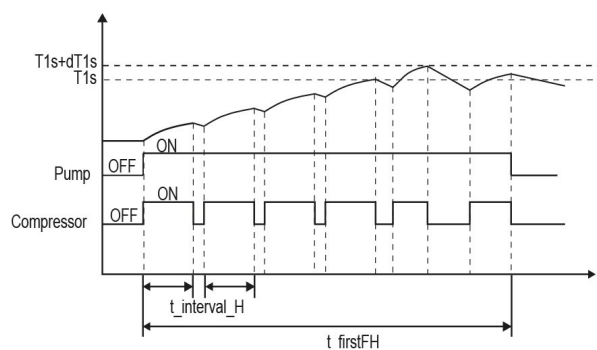

If FLOOR DRYING UP is selected, after press OK ,the page will displayed as follows:

12.2 FLOOR DRYING UP	
t_DRYUP	8 days
t_HIGHPEAK	5 days
t_DRYDOWN	5 days
T_DRYPEAK	45°C
START TIME	15:00
ADJUST	▶

12.2 FLOOR DRYING UP	
START DAY	01-01-2019
ENTER	EXIT
ADJUST	▶

7 START-UP AND CONFIGURATION

When the cursor is on OPERATE FLOOR DRYING?
Use UP/DOWN to scroll to YES and press OK.
The page will be displayed as follows:

12.2 FLOOR DRYING UP	
DO YOU WANT TO TURN OFF THE	
FLOOR DRYING UP FUNCTION?	
NO	YES
OK CONFIRM	

During floor drying, all the buttons except OK are invalid.
When the heat pump malfunctions, the floor drying mode will turn off when the backup heater and additional heating source is unavailable.
If you want to turn off floor drying up, please press OK.
The following page will be displayed:

12.3 FLOOR DRYING UP	
THE UNIT WILL OPERATE FLOOR	
DRYING UP ON 09:00 01-03-2018.	
OK CONFIRM	

The target outlet water temperature during floor drying up described in the picture below:

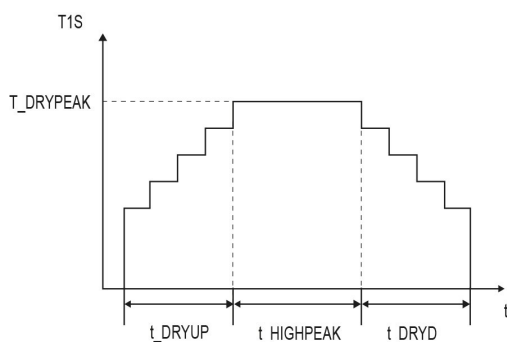

Auto restart

The AUTO RESTART function is used to select whether the unit reapplies the user interface settings at the time when power returns after a power supply failure.

How to set the auto restart

Go to MENU > FOR SERVICEMAN > AUTO RESTART

13 AUTO RESTART	
13.1 COOL/HEAT MODE	YES
13.2 DHW MODE	NON
ADJUST	

If the auto restart function is enabled, when power returns after a power supply failure, the AUTO RESTART function reapplies the user interface settings at the time of the power supply failure.

Power input limitation

14 POWER INPUT LIMITATION	
14.1 POWER INPUT LIMITATION	0
ADJUST	

Input define

15 INPUT DEFINE	
15.1 ON/OFF(M1M2)	REMOTE
15.2 SMART GRID	NO
15.3 T1B(Tw2)	NO
15.4 Tbt1	NO
ADJUST	

15 INPUT DEFINE	
15.6 Ta	HMI
15.7 Ta-adj	-2°C
15.8 SOLAR INPUT	NON
15.9 F-PIPE LENGTH	<10m
15.10 RT/Ta_PCB	NON
ADJUST	

15 INPUT DEFINE	
15.11 PUMPI SILENT MODE	NON
ADJUST	

Cascade set

16 CASCADE SET	
16.1 PER_START	20%
16.2 TIME_ADJUST	5 MIN
16.3 ADDRESS RESET	FF
← ADJUST	

After setting the address, you need to press the “UNLOCK” key to confirm.

The address “FF” is an invalid address code.

HMI address set

17 HMI ADDRESS SET	
HMI SET	MASTER
HMI ADDRESS FOR BMS	0
← ADJUST →	

When HMI SET is set to SLAVE, the controller can only switch the operation mode, turn on or off, set the temperate, and cannot set other paramters and functions.

The address “FF” is an invalid address code.

Test run and final check

The installer is obliged to verify correct operation of unit after installation.

Final check

Before switching on the unit, read following recommendations:

- When the complete installation and all necessary settings have been carried out, close all front panels of the unit and refit the unit cover.
- The service panel of the switch box may only be opened by a licensed electrician for maintenance.

NOTE

That during the first running period of the unit, required power input may be higher than stated on the nameplate of the unit.

This phenomenon originates from the compressor that needs elapse of a 50 hours run in period before reaching smooth operation and stable power consumption.

Test run operation (manual)

If required, the installer can perform a manual test run operation at any time to check correct operation of air purge, heating, cooling and domestic water heating, refer to TEST RUN.

7 START-UP AND CONFIGURATION

Parameters relating to functions reserved for technicians.

	Code	State	Default	Min	max	setting interval	unit
1.1	DHW MODE	Enable or disable the DHW mode:0=NON,1=YES	1	0	1	1	/
1.2	DISINFECT	Enable or disable the disinfect mode:0=NON,1=YES	1	0	1	1	/
1.3	DHW PRIORITY	Enable or disable the DHW priority mode:0=NON,1=YES	1	0	1	1	/
1.4	DHW PUMP	Enable or disable the DHW pump mode:0=NON,1=YES	0	0	1	1	/
1.5	DHW PRIORITY TIME SET	Enable or disable the DHW priority time set:0=NON,1=YES	0	0	1	1	/
1.6	dT5_ON	The temperature difference for starting the heat pump	5	2	10	1	°C
1.7	dT1S5	The difference value between Twout and T5 in DHW mode	10	5	40	1	°C
1.8	T4DHWMAX	The maximum ambient temperature that the heat pump can operate at for domestic water heating	43	35	43	1	°C
1.9	T4DHWMIN	The minimum ambient temperature that the heat pump can operate for domestic water heating	-10	-25	30	1	°C
1.10	t_INTERVAL_DHW	the start time interval of the compressor in DHW mode.	5	5	30	1	MIN
1.11	dT5_TBH_OFF	the temperature difference between T5 and T5S that turns the booster heater off.	5	0	10	1	°C
1.12	T4_TBH_ON	the highest outdoor temperature the TBH can operate.	5	-5	50	1	°C
1.13	t_TBH_DELAY	the time that the compressor has run before starting the booster heater	30	0	240	5	MIN
1.14	T5S_DI	the target temperature of water in the domestic hot water tank in the DISINFECT function.	65	60	70	1	°C
1.15	t_DI_HIGHTEMP.	the time that the highest temperature of water in the domestic hot water tank in the DISINFECT function will last	15	5	60	5	MIN
1.16	t_DI_MAX	the maximum time that disinfection will last	210	90	300	5	MIN
1.17	t_DHWHP_RESTRICT	the operation time for the space heating/cooling operation.	30	10	600	5	MIN
1.18	t_DHWHP_MAX	the maximum continuous working period of the heat pump in DHW PRIORITY mode.	90	10	600	5	MIN
1.19	PUMP RUNNING TIME	the certain time that the DHW pump will keep running for	5	5	120	1	MIN
1.20	DHW PUMP TIME RUN	Enable or disable the DHW pump run as timed and keeps running for PUMP RUNNING TIME:0=NON,1=YES	1	0	1	1	/
1.21	DHW PUMP DISINFECT	Enable or disable the DHW pump operate when the unit is in disinfect mode and $T5 \geq T5S_DI-2$:0=NON,1=YES	1	0	1	1	/
2.1	COOL MODE	Enable or disable the cooling mode:0=NON,1=YES	1	0	1	1	/
2.2	t_T4_FRESH_C	The refresh time of climate related curves for cooling mode	0.5	0.5	6	0.5	hours
2.3	T4CMAX	The highest ambient operation temperature for cooling mode	52	35	52	1	°C
2.4	T4CMIN	the lowest ambient operating temperature for cooling mode	10	-5	25	1	°C
2.5	dT1SC	the temperature difference for starting the heat pump(T1)	5	2	10	1	°C
2.6	dTSC	the temperature difference for starting the heat pump(Ta)	2	1	10	1	°C
2.7	t_INTERVAL_C	the start time interval of the compressor in cooling mode.	5	5	30	1	MIN
2.8	T1SETC1	The setting temperature 1 of climate related curves for cooling mode.	10	5	25	1	°C
2.9	T1SETC2	The setting temperature 2 of climate related curves for cooling mode.	16	5	25	1	°C

Default: factory value

Setting interval: adjustment range

7 START-UP AND CONFIGURATION

	Code	State	Default	Min	max	setting interval	unit
2.10	T4C1	The ambient temperature 1 of climate related curves for cooling mode.	35	-5	46	1	°C
2.11	T4C2	The ambient temperature 1 of climate related curves for cooling mode.	25	-5	46	1	°C
2.12	ZONE1 C-EMISSION	The type of zone1 end for cooling mode : 0=FCU(fan coil unit) · 1=RAD.(radiator) · 2=FLH(floor heating)	0	0	2	1	/
2.13	ZONE2 C-EMISSION	The type of zone2 end for cooling mode : 0=FCU(fan coil unit) · 1=RAD.(radiator) · 2=FLH(floor heating)	0	0	2	1	/
3.1	HEAT MODE	Enable or disable the heating mode	1	0	1	1	/
3.2	t_T4_FRESH_H	The refresh time of climate related curves for heating mode	0.5	0.5	6	0.5	hours
3.3	T4HMAX	The maximum ambient operating temperature for heating mode	25	20	35	1	°C
3.4	T4HMIN	The minimum ambient operating temperature for heating mode	-15	-25	30	1	°C
3.5	dT1SH	The temperature difference for starting the unit (T1)	5	2	20	1	°C
3.6	dTSH	The temperature difference for starting the unit (Ta)	2	1	10	1	°C
3.7	t_INTERVAL_H	The compressor start time interval	5	5	60	1	MIN
3.8	T1SETH1	The setting temperature 1 of climate related curves for heating mode	35	25	65	1	°C
3.9	T1SETH2	The setting temperature 2 of climate related curves for heating mode	28	25	65	1	°C
3.10	T4H1	The ambient temperature 1 of climate related curves for heating mode	-5	-25	35	1	°C
3.11	T4H2	The ambient temperature 2 of climate related curves for heating mode	7	-25	35	1	°C
3.12	ZONE1 H-EMISSION	The type of zone1 end for heating mode : 0=FCU(fan coil unit) · 1=RAD.(radiator) · 2=FLH(floor heating)	1	0	2	1	/
3.13	ZONE2 H-EMISSION	The type of zone2 end for heating mode : 0=FCU(fan coil unit) · 1=RAD.(radiator) · 2=FLH(floor heating)	2	0	2	1	/
3.14	t_DELAY_PUMP	the time that the compressor has run before starting the pump.	2	0.5	20	0.5	MIN
4.1	T4AUTOCMIN	The minimum operating ambient temperature for cooling in auto mode	25	20	29	1	°C
4.2	T4AUTOHMAX	The maximum operating ambient temperature for heating in auto mode	17	10	17	1	°C
5.1	WATER FLOW TEMP.	Enable or disable the WATER FLOW TEMP.:0=NON,1=YES	1	0	1	1	/
5.2	ROOM TEMP.	Enable or disable the ROOM TEMP.:0=NON,1=YES	0	0	1	1	/
5.3	DOUBLE ZONE	Enable or disable the ROOM THERMOSTAT DOUBLE ZONE:0=NON,1=YES	0	0	1	1	/
6.1	ROOM THERMOSTAT	The style of room thermostat : 0=NON,1=MODE SET,2=ONE ZONE,3=DOUBLE ZONE	0	0	3	1	/

7 START-UP AND CONFIGURATION

	Code	State	Default	Min	max	setting interval	unit
7.1	dT1_IBH_ON	The temperature difference between T1S and T1 for starting the backup heater.	5	2	10	1	°C
7.2	t_IBH_DELAY	The time that the compressor has run before the first backup heater turns on	30	15	120	5	MIN
7.3	T4_IBH_ON	The ambient temperature for starting the backup heater	-5	-15	30	1	°C
7.4	dT1_AHS_ON	The temperature difference between T1S and TW2 for turning the additional heating source on	5	2	10	1	°C
7.5	t_AHS_DELAY	The time that the compressor has run before starting the additional heating source	30	5	120	5	MIN
7.6	T4_AHS_ON	The ambient temperature for starting the additional heating source	-5	-15	30	1	°C
7.7	IBH_LOCATE	IBH/AHS installation location PIPE LOOP=0; BUFFER TANK=1	0	0	0	0	°C
7.8	P_IBH1	Power input of IBH1	0	0	20	0.5	kW
7.9	P_IBH2	Power input of IBH2	0	0	20	0.5	kW
7.10	P_TBH	Power input of TBH	2	0	20	0.5	kW
8.1	T1S_H.A_H	The target outlet water temperature for space heating when in holiday away mode	25	20	25	1	°C
8.2	T5S_H.A_DHW	The target outlet water temperature for domestic hot water heating when in holiday away mode	25	20	25	1	°C
12.1	PREHEATING FOR FLOOR T1S	The setting temperature of outlet water during first preheating for floor	25	25	35	1	□
12.3	t_FIRSTFH	The time last for preheating floor	72	48	96	12	HOURL
12.4	t_DRYUP	The day for warming up during floor drying up	8	4	15	1	DAY
12.5	t_HIGHPEAK	The continue days in high temperature during floor drying up	5	3	7	1	DAY
12.6	t_DRYD	The day of dropping temperature during floor drying up	5	4	15	1	DAY
12.7	T_DRYPEAK	The target peak temperature of water flow during floor drying up	45	30	55	1	□
12.8	START TIME	The start time of floor drying up	*	0:00	23:30	1/30	h/min
12.9	START DATE	The start date of floor drying up	The present date	1-1-2000	31-12-2099	1-1-2001	d/m/y
13.1	AUTO RESTART COOL/HEAT MODE	Enable or disable the auto restart cooling/heating mode. 0=NON , 1=YES	1	0	1	1	/
13.2	AUTO RESTART DHW MODE	Enable or disable the auto restart DHW mode. 0=NON , 1=YES	1	0	1	1	/
14.1	POWER INPUT LIMITATION	The type of power input limitation, 0=NON, 1~8=TYPE 1~8	0	0	8	1	/

* Hour : the present time (not on the hour +1, on the hour +2) Minute:00

7 START-UP AND CONFIGURATION

	Code	State	Default	Min	max	setting interval	unit
15.1	CN12 ON/OFF	Define the CN12 port,0= REMOTE ON/OFF,1= TBH ON/OFF 2= AHS ON/OFF	0	0	1	1	/
15.2	SMART GRID	Enable or disable the SMART GRID. 0=NON 1=YES	0	0	1	1	/
15.3	T1b (Tw2)	Enable or disable the T1b (Tw2) 0=NON,1=YES	0	0	1	1	/
15.4	Tbt1	Enable or disable the Tbt1; 0=NON,1=YES	0	0	1	1	/
15.6	Ta	Enable or disable the Ta; 0=NON,1=YES	0	0	1	1	/
15.7	Ta-adj	The corrected value of Ta on wired controller	-2	-10	1	1	°C
15.8	SOLAR INPUT	Choose the SOLAR INPUT; 0=NON,1=CN18Tsolar,2=CN11SL1SL2	0	0	2	1	/
15.9	F-PIPE LENGTH	Choose the total length of the liquid pipe(F-PIPE LENGTH);	0	0	1	1	/
15.10	RT/Ta_PCB	Enable or disable the RT/Ta_PCB; 0=NON,1=YES	0	0	1	1	/
15.11	PUMPI SILENT MODE	Enable or disable PUMPI SILENT MODE 0=NON, 1=YES	0	0	1	1	/
16.1	PER_START	Start-up percentage of multiple units	10	10	100	10	%
16.2	TIME_ADJUST	Adjustment time of adding and subtracting units	10	0	60	1	MIN
16.3	ADDRESS RESET	Reset the address code of the unit	FF	FF +0	-F	1	/
17.1	HMI SET	Choose the HMI; 0=MASTER,1=SLAVE	0	0	1	1	/
17.2	HMI ADDRESS FOR BMS	Set the HMI address code for BMS	0	0	15		

8 SERVICE INFORMATION

DANGER

Risk of fire / flammable materials



- 1) Checks to the area
Prior to beginning work on systems containing flammable refrigerants, safety checks are necessary to ensure that the risk of ignition is minimised. For repair to the refrigerating system, the following precautions shall be complied with prior to conducting work on the system.
- 2) Work procedure
Works shall be undertaken under a controlled procedure so as to minimise the risk of a flammable gas or vapour being present while the work is being performed.
- 3) General work area
All maintenance staff and others working in the local area shall be instructed on the nature of work being carried out. Work in confined spaces shall be avoided. The area around the work space shall be sectioned off. Ensure that the conditions within the area have been made safe by control of flammable material.
- 4) Checking for presence of refrigerant
The area shall be checked with an appropriate refrigerant detector prior to and during work, to ensure the technician is aware of potentially flammable atmospheres. Ensure that the leak detection equipment being used is suitable for use with flammable refrigerants, i.e. no sparking, adequately sealed or intrinsically safe.
- 5) Presence of fire extinguisher
If any hot work is to be conducted on the refrigeration equipment or any associated parts, appropriate fire extinguishing equipment shall be available to hand. Have a dry power or CO2 fire extinguisher adjacent to the charging area.
- 6) No ignition sources
No person carrying out work in relation to a refrigeration system which involves exposing any pipe work that contains or has contained flammable refrigerant shall use any sources of ignition in such a manner that it may lead to the risk of fire or explosion. All possible ignition sources, including cigarette smoking, should be kept sufficiently far away from the site of installation, repairing, removing and disposal, during which flammable refrigerant can possibly be released to the surrounding space. Prior to work taking place, the area around the equipment is to be surveyed to make sure that there are no flammable hazards or ignition risks. NO SMOKING signs shall be displayed.
- 7) Ventilated area
Ensure that the area is in the open or that it is adequately ventilated before breaking into the system or conducting any hot work. A degree of ventilation shall continue during the period that the work is carried out. The ventilation should safely disperse any released refrigerant and preferably expel it externally into the atmosphere.
- 8) Checks to the refrigeration equipment
Where electrical components are being changed, they shall be fit for the purpose and to the correct specification. At all times the manufacturer's maintenance and service guidelines shall be followed. If in doubt consult the manufacturer's technical department for assistance. The following checks shall be applied to installations using flammable refrigerants:
 - The charge size is in accordance with the room size within which the refrigerant containing parts are installed;
 - The ventilation machinery and outlets are operating adequately and are not obstructed;
 - If an indirect refrigerating circuit is being used, the secondary circuits shall be checked for the presence of refrigerant; marking to the equipment continues to be visible and legible.
 - Marking and signs that are illegible shall be corrected;
 - Refrigeration pipe or components are installed in a position where they are unlikely to be exposed to any substance which may corrode refrigerant containing components, unless the components are constructed of materials which are inherently resistant to being corroded or are suitably protected against being so corroded.
- 9) Checks to electrical devices
Repair and maintenance to electrical components shall include initial safety checks and component inspection procedures. If a fault exists that could compromise safety, then no electrical supply shall be connected to the circuit until it is satisfactorily dealt with. If the fault cannot be corrected immediately but it is necessary to continue operation, and adequate temporary solution shall be used. This shall be reported to the owner of the equipment so all parties are advised.

Initial safety checks shall include:

- That capacitors are discharged: this shall be done in a safe manner to avoid possibility of sparking;
- That there no live electrical components and wiring are exposed while charging, recovering or purging the system;
- That there is continuity of earth bonding.

10) Repairs to sealed components

a) During repairs to sealed components, all electrical supplies shall be disconnected from the equipment being worked upon prior to any removal of sealed covers, etc. If it is absolutely necessary to have an electrical supply to equipment during servicing, then a permanently operating form of leak detection shall be located at the most critical point to warn of a potentially hazardous situation.

b) Particular attention shall be paid to the following to ensure that by working on electrical components, the casing is not altered in such a way that the level of protection is affected. This shall include damage to cables, excessive number of connections, terminals not made to original specification, damage to seals, incorrect fitting of glands, etc.

- Ensure that apparatus is mounted securely.
- Ensure that seals or sealing materials have not degraded such that they no longer serve the purpose of preventing the ingress of flammable atmospheres. Replacement parts shall be in accordance with the manufacturer s specifications.

NOTE

The use of silicon sealant may inhibit the effectiveness of some types of leak detection equipment. Intrinsically safe components do not have to be isolated prior to working on them.

11) Repair to intrinsically safe components

Do not apply any permanent inductive or capacitance loads to the circuit without ensuring that this will not exceed the permissible voltage and current permitted for the equipment in use. Intrinsically safe components are the only types that can be worked on while live in the presence of a flammable atmosphere.

The test apparatus shall be at the correct rating. Replace components only with parts specified by the manufacturer. Other parts may result in the ignition of refrigerant in the atmosphere from a leak.

12) Cabling

Check that cabling will not be subject to wear, corrosion, excessive pressure, vibration, sharp edges or any other adverse environmental effects.

The check shall also take into account the effects of aging or continual vibration from sources such as compressors or fans.

13) Detection of flammable refrigerants Under no circumstances shall potential sources of ignition be used in the searching for or detection of refrigerant leaks. A halide

14) Leak detection methods

The following leak detection methods are deemed acceptable for systems containing flammable refrigerants.

Electronic leak detectors shall be used to detect flammable refrigerants, but the sensitivity may not be adequate, or may need re-calibration.(Detection equipment shall be calibrated in a refrigerant-free area.)

Ensure that the detector is not a potential source of ignition and is suitable for the refrigerant.

Leak detection equipment shall be set at a percentage of the LFL of the refrigerant and shall be calibrated to the refrigerant employed and the appropriate percentage of gas (25% maximum) is confirmed.

Leak detection fluids are suitable for use with most refrigerants but the use of detergents containing chlorine shall be avoided as the chlorine may react with the refrigerant and corrode the copper pipe-work.

If a leak is suspected ,all naked flames shall be removed or extinguished. If a leakage of refrigerant is found which requires brazing, all of the refrigerant shall be recovered from the system, or isolated(by means of shut off valves) in a part of the system remote from the leak .

Oxygen free nitrogen(OFN) shall then be purged through the system both before and during the brazing process.

8 SERVICE INFORMATION

14) Removal and evacuation

When breaking into the refrigerant circuit to make repairs or for any other purpose conventional procedures shall be used, However, it is important that best practice is followed since flammability is a consideration. The following procedure shall be

- Remove refrigerant;
- Purge the circuit with inert gas; Evacuate;
- Purge again with inert gas;
- Open the circuit by cutting or brazing.
- The refrigerant charge shall be recovered into the correct recovery cylinders. The system shall be flushed with OFN to render the unit safe. This process may need to be repeated several times.
- Compressed air or oxygen shall not be used for this task.
- Flushing shall be achieved by breaking the vacuum in the system with OFN and continuing to fill until the working pressure is achieved, then venting to atmosphere, and finally pulling down to a vacuum. This process shall be repeated until no refrigerant is within the system.
- When the final OFN charge is used, the system shall be vented down to atmospheric pressure to enable work to take place. This operation is absolutely vital if brazing operations on the pipe-work are to take place.
- Ensure that the outlet for the vacuum pump is not closed to any ignition sources and there is ventilation available.

16) Charging procedures

In addition to conventional charging procedures, the following requirements shall be followed:

- Ensure that contamination of different refrigerants does not occur when using charging equipment. Hoses or lines shall be as short as possible to minimize the amount of refrigerant contained in them.
- Cylinders shall be kept upright.
Ensure that the refrigeration system is earthed prior to charging the system with refrigerant.
Label the system when charging is complete(if not already).
Extreme care shall be taken not to overfill the refrigeration system.
- Prior to recharging the system it shall be pressure tested with OFN. The system shall be leak tested on completion of charging but prior to commissioning. A follow up leak test shall be carried out prior to leaving the site.

17) Decommissioning

Before carrying out this procedure, it is essential that the technician is completely familiar with the equipment and all its detail. It is recommended good practice that all refrigerants are recovered safely. Prior to the task being carried out, an oil and refrigerant sample shall be taken.

In case analysis is required prior to re-use of reclaimed refrigerant. It is essential that electrical power is available before the task is commenced.

- a) Become familiar with the equipment and its operation.
- b) Isolate system electrically
- c) Before attempting the procedure ensure that:
 - Mechanical handling equipment is available, if required, for handling refrigerant cylinders;
 - All personal protective equipment is available and being used correctly;
 - The recovery process is supervised at all times by a competent person;
 - Recovery equipment and cylinders conform to the appropriate standards.
- d) Pump down refrigerant system, if possible.
- e) If a vacuum is not possible, make a manifold so that refrigerant can be removed from various parts of the system.
- f) Make sure that cylinder is situated on the scales before recovery takes place.
- g) Start the recovery machine and operate in accordance with manufacturer's instructions.
- h) Do not overfill cylinders. (No more than 80% volume liquid charge).
- i) Do not exceed the maximum working pressure of the cylinder, even temporarily.
- j) When the cylinders have been filled correctly and the process completed, make sure that the cylinders and the equipment are removed from site promptly and all isolation valves on the equipment are closed off.
- k) Recovered refrigerant shall not be charged into another refrigeration system unless it has been cleaned and checked.

18) Labelling

Equipment shall be labelled stating that it has been de-commissioned and emptied of refrigerant. The label shall be dated and signed. Ensure that there are labels on the equipment stating the equipment contains flammable refrigerant.

19) Recovery

- When removing refrigerant from a system, either for service or decommissioning, it is recommended good practice that all refrigerants are removed safely.
- When transferring refrigerant into cylinders, ensure that only appropriate refrigerant recovery cylinders are employed. Ensure that the correct numbers of cylinders for holding the total system charge are available.
- All cylinders to be used are designated for the recovered refrigerant and labelled for that refrigerant (i.e special cylinders for the recovery of refrigerant). Cylinders shall be complete with pressure relief valve and associated shut-off valves in good working order.
- Empty recovery cylinders are evacuated and, if possible, cooled before recovery occurs.
- The recovery equipment shall be in good working order with a set of instructions concerning the equipment that is at hand and shall be suitable for the recovery of flammable refrigerants. In addition, a set of calibrated weighing scales shall be available and in good working order.
- Hoses shall be complete with leak-free disconnect couplings and in good condition. Before using the recovery machine, check that it is in satisfactory working order, has been properly maintained and that any associated electrical components are sealed to prevent ignition in the event of a refrigerant release. Consult manufacturer if in doubt.
- The recovered refrigerant shall be returned to the refrigerant supplier in the correct recovery cylinder, and the relevant Waste Transfer Note arranged. Do not mix refrigerants in recovery units and especially not in cylinders.
- If compressors or compressor oils are to be removed, ensure that they have been evacuated to an acceptable level to make certain that flammable refrigerant does not remain within the lubricant. The evacuation process shall be carried out prior to retraining the compressor to the suppliers. Only electric heating to the compressor body shall be employed to accelerate this process. When oil is drained from a system, it shall be carried out safely.

20) Transportation, marking and storage for units

- Transport of equipment containing flammable refrigerants Compliance with the transport regulations
- Marking of equipment using signs Compliance with local regulations
- Disposal of equipment using flammable refrigerants Compliance with national regulations
- Storage of equipment/appliances
- The storage of equipment should be in accordance with the manufacturer's instructions.
- Storage of packed (unsold) equipment
- Storage package protection should be constructed such that mechanical damage to the equipment inside the package will not cause a leak of the refrigerant charge.
- The maximum number of pieces of equipment permitted to be stored together will be determined by local regulations.

9 MAINTENANCE

In order to ensure optimal availability of the unit, a number of checks and inspections on the unit and the field wiring have to be carried out at regular intervals.

This maintenance has to be carried out by your local Clivet technician.

DANGER

ELECTRIC SHOCK

- Before carrying out any maintenance or repair activity, always switch off the circuit breaker on the supply panel, remove the fuses (or switch off the circuit breakers) or open protection devices of the unit.
- Make sure that before starting any maintenance or repair activity that the power supply to the outdoor unit is switched off.
- Do not touch live parts for 10 minutes after the power supply is turned off because of high voltage risk.
- The heater for the compressor may operate even in stop mode.
- Please note that some sections of the electric component box are hot.
- Make sure you do not touch a conductive section.
- Do not rinse the unit. This may cause electric shocks or fire.
- When service panels are removed, live parts can be easily touched by accident.
- Never leave the unit unattended during installation or servicing when service panel is removed.

- Backup heater vessel insulation cover
Check that the backup heater insulation cover is fastened tightly around the backup heater vessel.
- Domestic hot water tank pressure relief valve (field supply).
Applies only to installations with a domestic hot water tank.
Check for correct operation of the pressure relief valve on the domestic hot water tank.
- Domestic hot water tank booster heater.
Applies only to installations with a domestic hot water tank. It is advisable to remove lime buildup on the booster heater to extend its life span, especially in regions with hard water.
To do so, drain the domestic hot water tank, remove the booster heater from the domestic hot water tank and immerse in a bucket (or similar) with lime-removing product for 24 hours.
- Unit switch box
Carry out a thorough visual inspection of the switch box and look for obvious defects such as loose connections or defective wiring.
Check for correct operation of contactors with an ohm meter. All contacts of these contactors must be in open position.
- Use of glycol
Refer to chapter WATER CONNECTIONS - Use of glycol
Document the glycol concentration and the pH-value in the system at least once a year.
A PH-value below 8.0 indicates that a significant portion of the inhibitor has been depleted and that more inhibitor needs to be added.
When the PH-value is below 7.0 then oxidation of the glycol occurred, the system should be drained and flushed thoroughly before severe damage occurs.
Make sure that the disposal of the glycol solution is done in accordance with relevant local laws and regulations.

The described checks must be executed at least once a year by qualified personnel.

- Water pressure
Check if the water pressure is above 1 bar. If necessary add water.
- Water filter
Clean the water filter.
- Water pressure relief valve
Check for correct operation of the pressure relief valve by turning the black knob on the valve counter-clockwise:
If you do not hear a clacking sound, contact your local dealer.
In case the water keeps running out of the unit, close both the water inlet and outlet shut-off valves first and then contact your local dealer.
- Pressure relief valve hose
Check that the pressure relief valve hose is positioned appropriately to drain the water.

Disassembling the unit

WARNING

Switch off all power i.e. unit power supply and backup heater and domestic hot water tank power supply before removing doors 1 and 2.

Parts inside the unit may be hot.

Push the grill to the left until it stops, then pull its right edge, so you can removed the grill.
You can also reverse the procedure. Be careful to avoid hand injury.

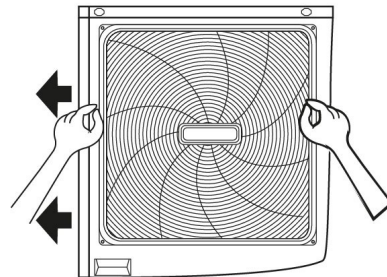
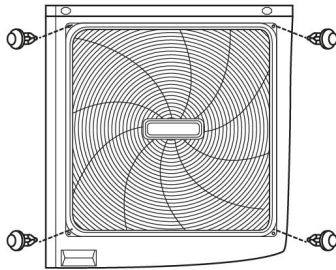

10 TROUBLE SHOOTING

This section provides useful information for diagnosing and correcting certain troubles which may occur in the unit. This troubleshooting and related corrective actions may only be carried out by your local technician.

General guidelines

Before starting the troubleshooting procedure, carry out a thorough visual inspection of the unit and look for obvious defects such as loose connections or defective wiring.

WARNIG

Quando si ispeziona il quadro elettrico dell'unità, accertarsi sempre che l'interruttore generale sia spento.

When a safety device was activated, stop the unit and find out why the safety device was activated before resetting it.

Under no circumstances can safety devices be bridged or changed to a value other than the factory setting.

If the cause of the problem cannot be found, call your local dealer.

If the pressure relief valve is not working correctly and is to be replaced, always reconnect the flexible hose attached to the pressure relief valve to avoid water dripping out of the unit!

NOTE

For problems related to the optional solar kit for domestic water heating, refer to the troubleshooting in the Installation & Owner's manual for that kit.

General symptoms

The unit is turned on but the unit is not heating or cooling as expected	
POSSIBLE CAUSES	CORRECTIVE ACTION
The temperature setting is not correct.	<p>Check the controller set point.</p> <p>T4HMAX, T4HMIN in heat mode.</p> <p>T4CMAX, T4CMIN in cool mode.</p> <p>T4DHWMAX, T4DHWMIN in DHW mode.</p>
The water flow is too low.	<ul style="list-style-type: none"> • Check that all shut off valves of the water circuit are completely open. • Check if the water filter needs cleaning. • Make sure there is no air in the system (purge air). • Check on the manometer that there is sufficient water pressure. The water pressure must be >1 bar (water is cold). • Make sure that the expansion vessel is not broken. • Check that the resistance in the water circuit is not too high for the pump.
The water volume in the installation is too low.	<p>Make sure that the water volume in the installation is above the minimum required value (refer to WATER CONNECTIONS - Checking the water volume and expansion vessel pre-pressure").</p>

The unit is turned on but the compressor is not starting (space heating or domestic water heating)	
POSSIBLE CAUSES	CORRECTIVE ACTION
The unit must start up out of its operation range (the water temperature is too low).	<p>In case of low water temperature, the system utilizes the backup heater to reach the minimum water temperature first (12°C).</p> <ul style="list-style-type: none"> • Check that the backup heater power supply is correct. • Check that the backup heater thermal fuse is closed. • Check that the backup heater thermal protector is not activated. • Check that the backup heater contactors are not broken.

Pump is making noise (cavitation)	
There is air in the system.	Purge air.
Water pressure at pump inlet is too low.	<ul style="list-style-type: none"> • Check on the manometer that there is sufficient water pressure. The water pressure must be > 1 bar (water is cold). • Check that the manometer is not broken. • Check that the expansion vessel is not broken. • Check that the setting of the pre- pressure of the expansion vessel is correct (refer to WATER CONNECTIONS - Checking the water volume and expansion vessel pre-pressure").

The water pressure relief valve opens	
The expansion vessel is broken.	Replace the expansion vessel.
The filling water pressure in the installation is higher than 0.3MPa.	Make sure that the filling water pressure in the installation is about 0.15~0.20MPa (refer to WATER CONNECTIONS - Checking the water volume and expansion vessel pre-pressure").

The water pressure relief valve leaks	
Dirt is blocking the water pressure relief valve outlet.	<p>Check for correct operation of the pressure relief valve by turning the red knob on the valve counter clockwise:</p> <ul style="list-style-type: none"> • If you do not hear a clacking sound, contact your local dealer. • In case the water keeps running out of the unit, close both the water inlet and outlet shut-off valves first and then contact your local dealer.

10 TROUBLE SHOOTING

Space heating capacity shortage at low outdoor temperatures	
Backup heater operation is not activated.	<p>Check that the "OTHER HEATING SOURCE/ BACKUP HEATER" is enabled, see chapter 9 Start-up and configuration - OTHER HEATING SOURCE.</p> <p>Check whether or not the thermal protector of the backup heater has been activated (see chapter to Electronic board layout - main control board to thermal protector of the backup heater for location of the reset button).</p> <p>Check if booster heater is running, the backup heater and booster heater can't operate simultaneously.</p>
Too much heat pump capacity is used for heating domestic hot water (applies only to installations with a domestic hot water tank).	<p>Check that the 't_DHWHP_MAX' and "t_DHWHP_RESTRICT" are configured appropriately:</p> <ul style="list-style-type: none"> • Make sure that the 'DHW PRIORITY' in the user interface is disabled. • Enable the "T4_TBH_ON" in the user interface/FOR SERVICEMAN to activate the booster heater for domestic water heating.

Heat mode can't change to DHW mode immediately	
Volume of tank is too small and the location of water temperature probe not high enough	<ul style="list-style-type: none"> • Set dT1s5 to 20, and set t_DHWHP_RESTRICT to minimum value. • Set dT1SH to 2. • Enable TBH, and TBH should be controlled by the outdoor unit. • If AHS(boiler) is available, turn boiler on first, if requirement for turn heat pump on is fulfilled, the heat pump will turn on. • If both TBH and AHS are not available, try to change the position of T5 probe

DHW mode can't change to Heat mode immediately	
Heat exchanger for space heating not big enough	<ul style="list-style-type: none"> • Set t_DHWHP_MAX to minimum value, the suggested value is 60min. • If circulating pump out of unit is not controlled by unit, try to connect it to the unit. • Add 3-way valve at the inlet of fan coil to ensure enough water flow.
Space heating load is small	Normal , no need for heating
Disinfect function is enabled but without TBH	<ul style="list-style-type: none"> • Disable disinfect function • add TBH or AHS for DHW mode
Manual activation of the FAST WATER function, after the hot water meets the requirements, the heat pump does not switch to conditioning mode	<ul style="list-style-type: none"> • Manual activation of the FAST WATER function
Ambient temperature is low, AHS does not activate.	<ul style="list-style-type: none"> • Set T4DHWMIN, suggested value ≥ -5 ° C • Set T4_TBH_ON, suggested value ≥ 5 ° C
DHW priority - DHW	<ul style="list-style-type: none"> • If AHS or IBH are present, when the unit is not operating, IBH or AHS must operate in DHW mode until the water temperature reaches the set temperature before entering heating mode.

Operation Parameter

This menu is for installer or service engineer reviewing the operation parameter.

- At home page, go to "MENU">"OPERATION PARAMETER".
- Press "OK".
- There are five pages for the operating parameter as following. Use UP DOWN scroll.

OPERATION PARAMETER	#01
ONLINE UNITS NUMBER	1
OPERATE MODE	COOL
SV1 STATE	ON
SV2 STATE	OFF
SV3 STATE	OFF
PUMP_I	ON
ADDRESS	1/9

OPERATION PARAMETER	#01
PUMP_O	OFF
PUMP_C	OFF
PUMP_S	OFF
PUMP_D	OFF
PIPE BACKUP HEATER	OFF
TANK BACKUP HEATER	ON
ADDRESS	2/9

OPERATION PARAMETER	#01
FAN SPEED	600R/MIN
IDU TARGET FREQUENCY	46Hz
FREQUENCY LIMITED TYPE	5
SUPPLY VOLTAGE	230V
DC GENERATRIX VOLTAGE	420V
DC GENERATRIX CURRENT	18A
ADDRESS	7/9

OPERATION PARAMETER	#01
TW_O PLATE W-OUTLET TEMP.	35°C
TW_I PLATE W-INLET TEMP.	30°C
T2 PLATE F-OUT TEMP.	35°C
T2B PLATE F-IN TEMP.	35°C
Th COMP. SUCTION TEMP.	5°C
Tp COMP. DISCHARGE TEMP.	75°C
ADDRESS	8/9

OPERATION PARAMETER	#01
GAS BOILER	OFF
T1 LEAVING WATER TEMP.	35°C
WATER FLOW	1.72m3/h
HEAT PUMP CAPACTIY	11.52kW
POWER CONSUM	1000kWh
Ta ROOM TEMP.	25°C
ADDRESS	3/9

OPERATION PARAMETER	#01
T5 WATER TANK TEMP.	53°C
Tw2 CIRCUIT2 WATER TEMP.	35°C
TIS' C1 CLI. CURVE TEMP.	35°C
TIS2' C2 CLI. CURVE TEMP.	35°C
TW_O PLATE W-OUTLET TEMP.	35°C
TW_I PLATE W-INLET TEMP.	30°C
ADDRESS	4/9

OPERATION PARAMETER	#01
T3 OUTDOOR EXCHANGE TEMP.	5°C
T4 OUTDOOR AIR TEMP.	5°C
TF MODULE TEMP.	55°C
P1 COMP. PRESSURE	2300kPa
ODU SOFTWARE	01-09-2018V01
HMI SOFTWARE	01-09-2018V01
ADDRESS	9/9

OPERATION PARAMETER	#01
Tbt1 BUFFERTANK_UP TEMP.	35°C
Tbt2 BUFFERTANK_LOW TEMP.	35°C
Tsolar	25°C
IDU SOFTWARE	01-09-2019V01
ADDRESS	5/9

OPERATION PARAMETER	#01
ODU MODEL	6kW
COMP.CURRENT	12A
COMP.FREQUENCY	24Hz
COMP.RUN TIME	54 MIN
COMP.TOTAL RUN TIME	1000Hrs
EXPANSION VALVE	200P
ADDRESS	6/9

INFORMATION

The power consumption parameter is preparatory.
Some parameter is not be activated in the system, the parameter will show "--"

10 TROUBLE SHOOTING

Error codes

When a safety device is activated, an error code will be displayed on the user interface.

A list of all errors and corrective actions can be found in the table below.

Reset the safety by turning the unit OFF and back ON.

In case this procedure for resetting the safety is not successful, contact your local dealer.

ERROR CODE	MALFUNCTION OR PROTECTION	FAILURE CAUSE AND CORRECTIVE ACTION
E0	Flow switch error (E8 displayed 3 times)	<ol style="list-style-type: none"> 1. The wire circuit is short connected or open. Reconnect the wire correctly. 2. Water flow rate is too low. 3. Water flow switch is failed, switch is open or close continuously, change the water flow switch.
E1	Phase sequence fault(only for threephase unit)	<ol style="list-style-type: none"> 1. Check the power supply cables should be connected stable, to avoid phase loss. 2. Check the power supply cables sequence, change any two cables sequence of the three power supply cables.
E2	Communication error between user interface and main control board of hydraulic module	<ol style="list-style-type: none"> 1. wire doesn't connect between wired controller and unit. connect the wire. 2. Communication wire sequence is not right. Reconnect the wire in the right sequence. 3. Whether there is a high magnetic field or high power interfere, such as lifts, large power transformers, etc.. <p>To add a barrier to protect the unit or to move the unit to the other place.</p>
1E3	2The backup heater exchanger outlet water temperature sensor (T1) error	<ol style="list-style-type: none"> 1. The T1 sensor connector is loosen. Reconnect it. 2. The T1 sensor connector is wet or there is water in. remove the water, make the connector dry. Add waterproof adhesive. 3. The T1 sensor failure, change a new sensor.
E4	The domestic hot water temperature sensor (T5) error.	<ol style="list-style-type: none"> 1. The T5 sensor connector is loosen. Reconnect it. 2. The T5 sensor connector is wet or there is water in. remove the water, make the connector dry. Add waterproof adhesive 3. The T5 sensor failure, change a new sensor.
E5	The condenser outlet refrigerant temperature sensor (T3)error.	<ol style="list-style-type: none"> 1. The T3 sensor connector is loosen. Reconnect it. 2. The T3 sensor connector is wet or there is water in. remove the water, make the connector dry. Add waterproof adhesive 3. The T3 sensor failure, change a new sensor.
E6	The ambient temperature sensor (T4) error.	<ol style="list-style-type: none"> 1. The T4 sensor connector is loosen. Reconnect it. 2. The T4 sensor connector is wet or there is water in. remove the water, make the connector dry. Add waterproof adhesive 3. The T4 sensor failure, change a new sensor.

ERROR CODE	MALFUNCTION OR PROTECTION	FAILURE CAUSE AND CORRECTIVE ACTION
E7	Tbt1 sensor error	<ol style="list-style-type: none"> 1. The Tbt1sensor connector is loosen. Re connect it. 2. The Tbt1sensor connector is wet or there is water in. remove the water, make the connector dry. Add waterproof adhesive 3. The Tbt1sensor failure, change a new sensor.
E8	Water flow failure	<p>Check that all shut off valves of the water circuit are completely open.</p> <ol style="list-style-type: none"> 1. Check if the water filter needs cleaning. 2. Refer to chapter WATER CONNECTIONS - Charging water 3. Make sure there is no air in the system(purge air). 4. Check on the manometer that there is sufficient water pressure. The water pressure must be >1 bar. 5. Check that the pump speed setting is on the highest speed. 6. Make sure that the expansion vessel is not broken. 7. Check that the resistance in the water circuit is not too high for the pump (refer to "Setting the pump speed"). 8. If this error occurs at defrost operation (during space heating or domestic water heating), make sure that the backup heater power supply is wired correctly and that fuses are not blown. 9. Check that the pump fuse and PCB fuse are not blown.
E9	Suction temperature sensor (Th) error	<ol style="list-style-type: none"> 1. The Th sensor connector is loosen. Re connect it. 2. The Th sensor connector is wet or there is water in. remove the water, make the connector dry. Add waterproof adhesive 3. The Th sensor failure, change a new sensor.
EA	Discharge temperature sensor (Tp) error	<ol style="list-style-type: none"> 1. The Tp sensor connector is loosen. Re connect it. 2. The Tp sensor connector is wet or there is water in. remove the water, make the connector dry. Add waterproof adhesive 3. The Tp sensor failure, change a new sensor.
Eb	Solar panel sensor error (Tsolar)	<ol style="list-style-type: none"> 1. The sensor connector is loosen. Re connect it. 2. The sensor connector is wet or there is water in. remove the water, make the connector dry. Add waterproof adhesive 3. The sensor failure, change a new sensor.
Ed	Tw_in inlet water temperature sensor error	<ol style="list-style-type: none"> 1. The Tw_in sensor connector is loosen. Re connect it. 2. The Tw_in sensor connector is wet or there is water in. remove the water, make the connector dry. Add waterproof adhesive 3. The Tw_in sensor failure, change a new sensor.

10 TROUBLE SHOOTING

ERROR CODE	MALFUNCTION OR PROTECTION	FAILURE CAUSE AND CORRECTIVE ACTION
EE	The main control board of hydraulic module EEPROM failure	<ol style="list-style-type: none"> 1. The EEPROM parameter is error, rewrite the EEPROM data. 2. EEPROM chip part is broken, change a new EEPROM chip part. 3. main control board of hydraulic module is broken, change a new PCB.
bH	PED board error	<ol style="list-style-type: none"> 1. Remove power supply and turn on again after 5 minutes; check if ok. 2. Replace the card, turn it back on and check if it is ok. 3. Replace the IPM module board.
H0	Communication error between main control board PCB B and main control board of hydraulic module	<ol style="list-style-type: none"> 1. wire doesn't connect between main control board PCB B and main control board of hydraulic module. connect the wire. 2. Communication wire sequence is not right. Reconnect the wire in the right sequence. 3. Whether there is a high magnetic field or high power interfere, such as lifts, large power transformers, etc.. To add a barrier to protect the unit or to move the unit to the other place.
H1	Communication error between inverter module PCB A and main control board PCB B	<ol style="list-style-type: none"> 1. Whether there is power connected to the PCB and driven board. Check the PCB indicator light is on or off. If Light is off, reconnect the power supply wire. 2. if light is on, check the wire connection between the main PCB and driven PCB, if the wire loosen or broken, reconnect the wire or change a new wire. 3. Replace a new main PCB and driven board in turn.
H2	The plate heat exchanger refrigerant inlet(liquid pipe) temperature sensor(T2) error.	<ol style="list-style-type: none"> 1. The T2 sensor connector is loosen. Re connect it. 2. The T2 sensor connector is wet or there is water in. remove the water, make the connector dry. Add waterproof adhesive 3. The T2 sensor failure, change a new sensor.
H3	The plate heat exchanger refrigerant outlet(gas pipe) temperature sensor (T2B) error.	<ol style="list-style-type: none"> 1. The T2B sensor connector is loosen. Re connect it. 2. The T2B sensor connector is wet or there is water in. remove the water, make the connector dry. Add waterproof adhesive 3. The T2B sensor failure, change a new sensor.
H4	Three times P6 protect	Same to P6
H5	The indoor temperature sensor (Ta) error	<ol style="list-style-type: none"> 1. The Ta sensor is in the interface; 2. The Ta sensor failure · change a new sensor or change a new interface.
H6	The DC fan failure	<ol style="list-style-type: none"> 1. Strong wind or typhoon below toward to the fan, to make the fan running in the opposite direction. Change the unit direction or make shelter to avoid typhoon below to the fan. 2. fan motor is broken, change a new fan motor.

10 TROUBLE SHOOTING

ERROR CODE	MALFUNCTION OR PROTECTION	FAILURE CAUSE AND CORRECTIVE ACTION
H7	Main circuit voltage failure	<ol style="list-style-type: none"> 1. Check that the power supply values are in the available range. 2. The unit was turned on and off several times at close intervals. Keep the unit turned off for at least 3 minutes before turning it on again. 3. Defective circuit in the main control board. Replace the main PCB.
H8	Pressure sensor error	<ol style="list-style-type: none"> 1. The pressure sensor connector is loose. Re connect it. 2. The pressure sensor has failed. Replace it.
H9	Tw2 sensor error	<ol style="list-style-type: none"> 1. The sensor connector is loosen. Re connect it. 2. The sensor connector is wet or there is water in. remove the water, make the connector dry. Add waterproof adhesive 3. The sensor failure, change a new sensor.
HA	TW_out plate heat exchanger water outlet temperature sensor error.	<ol style="list-style-type: none"> 1. The TW_out sensor connector is loosen. Re connect it. 2. The TW_out sensor connector is wet or there is water in. remove the water, make the connector dry. Add waterproof adhesive 3. The TW_out sensor failure, change a new sensor.
Hb	the PP protection trips 3 times and Tw_out <7 ° C	<ol style="list-style-type: none"> 1. see PP
Hd	Communication error between master and slave unit	<ol style="list-style-type: none"> 1. incorrect address 2. incorrect wiring 3. check board fuse 4. wiring H1-H2
HE	Communication error between main board and thermostat	The outside ambient temperature is too high(higher than 30°C, the unit still operate heat mode. close the heat mode when the ambient temperature is higher than 30°C
HF	Inverter module EEprom error	<ol style="list-style-type: none"> 1. The EEprom parameter is error, rewrite the EEprom data. 2. EEprom chip part is broken, change a new EEprom chip part. 3. Main PCB is broken, change a new PCB.
HH	H6 displayed 10 times in 2 hours	Refer to H6
HL	PFC module fault	Contact your local dealer
HP	Low pressure protection (Pe<0.6) occurred 3 times in an	Refer to P0

10 TROUBLE SHOOTING

ERROR CODE	MALFUNCTION OR PROTECTION	FAILURE CAUSE AND CORRECTIVE ACTION
P0	Low pressure protection	<ol style="list-style-type: none"> 1. System is lack of refrigerant volume. Charge the refrigerant in right volume. 2. When at heating mode or heat water mode, Heat exchanger is dirty or something is block on the surface. Clean the heat exchanger or remove the obstruction. 3. The water flow is low in cooling mode. 4. Electrical expansion valve locked or winding connector is loosen. Tap-tap the valve body and plug in/ plug off the connector for several times to make sure the valve is working correctly. And install the winding in the right location.
P1	High pressure protection	<p>Heating mode, DHW mode:</p> <ol style="list-style-type: none"> 1. The water flow is low; water temp is high, whether there is air in the water system. Release the air. 2. Water pressure is lower than 0.1Mpa, charge the water to let the pressure in the range of 0.15~0.2Mpa. 3. Over charge the refrigerant volume. Recharge the refrigerant in right volume. 4. Electrical expansion valve locked or winding connector is loosen. Tap-tap the valve body and plug in/ plug off the connector for several times to make sure the valve is working correctly. And install the winding in the right location <p>DHW mode: Water tank heat exchanger is smaller than the required 1.7m². (10-16kW unit) or 1.4m² (5-9kW unit)</p> <p>Cooling mode:</p> <ol style="list-style-type: none"> 1. Heat exchanger cover is not removed. Remove it. 2. Heat exchanger is dirty or something is block on the surface. Clean the heat exchanger or remove the obstruction.
P3	Compressor overcurrent protection.	<ol style="list-style-type: none"> 1. The same reason to P1. 2. Power supply voltage of the unit is low, increase the power voltage to the required range.
P4	High discharge temperature protection.	<ol style="list-style-type: none"> 1. The same reason to P1. 2. System is lack of refrigerant volume. Charge the refrigerant in right volume. 3. TW_out temp sensor is loosen Reconnect it.. 4. T1 temp sensor is loosen. Reconnect it. 5. T5 temp sensor is loosen. Reconnect it.

ERROR CODE	MALFUNCTION OR PROTECTION	FAILURE CAUSE AND CORRECTIVE ACTION
P5	High Temperature difference protection between water inlet and water outlet of the plate heat exchanger.	<ol style="list-style-type: none"> 1. Check that all shut off valves of the water circuit are completely open. 2. Check if the water filter needs cleaning. 3. Refer to chapter WATER CONNECTIONS - Charging water" 4. Make sure there is no air in the system (purge air). 5. Check on the manometer that there is sufficient water pressure. The water pressure must be >1 bar(water is cold). 6. Check that the pump speed setting is on the highest speed. 7. Make sure that the expansion vessel is not broken. 8. Check that the resistance in the water circuit is not too high for the pump. (refer to START-UP AND CONFIGURATION - Setting the pump speed).
P6	Module protection	<ol style="list-style-type: none"> 1. Power supply voltage of the unit is low, increase the power voltage to the required range. 2. The space between the units is too narrow for heat exchange. Increase the space between the units. 3. Heat exchanger is dirty or something is block on the surface. Clean the heat exchanger or remove the obstruction. 4. Fan is not running. Fan motor or fan is broken, Change a new fan or fan motor. 5. Over charge the refrigerant volume. Recharge the refrigerant in right volume. 6. Water flow rate is low, there is air in system, or pump head is not enough. Release the air and reselect the pump. 7. Water outlet temp sensor is loosen or broken, reconnect it or change a new one. 8. water tank heat exchanger is smaller than the required 1.7m².(10-16kW unit) or 1.4m² (5-9kW unit). 9. Module wires or screws are loosen. Reconnect wires and screws. 10. The Thermal Conductive Adhesive is dry or drop.Add some thermal conductive adhesive. 11. The wire connection is loosen or drop. Reconnect the wire. 12. Drive board is defective, replace a new one. 13. If already confirm the control system has no problem, then compressor is defective, replace a new compressor.
P9	DC fan motor protect	Contact your local dealer
Pd	High temperature protection of refrigerant outlet temp of condenser.	<ol style="list-style-type: none"> 1. Heat exchanger cover is not removed. Remove it. 2. Heat exchanger is dirty or something is block on the surface. Clean the heat exchanger or remove the obstruction. 3. There is no enough space around the unit for heat exchanging. 4. fan motor is broken, replace a new one.

10 TROUBLE SHOOTING

ERROR CODE	MALFUNCTION OR PROTECTION	FAILURE CAUSE AND CORRECTIVE ACTION
Pb	Anti-freeze mode protection	Unit will return to the normal operation automatically.
PP	Water inlet temperature is higher than water outlet in heating mode	<ol style="list-style-type: none"> 1. The water inlet/outlet sensor wire connector is loosen. Reconnect it. 2. The water inlet/outlet (TW_in /TW_out) sensor is broken, Change a new sensor. 3. Four-way valve is blocked. Restart the unit again to let the valve change the direction. 4. Four-way valve is broken, change a new valve.
F1	DC generatrix voltage is too low	<ol style="list-style-type: none"> 1. Check the power supply. 2. If the power supply is OK, and check if LED light is OK, check the voltage PN, if it is 380V, the problem usually comes from the main board. And if the light is OFF, disconnect the power, check the IGBT, check those dioxides, if the voltage is not correct, the inverter board is damaged, change it. 3. And if those IGBT are OK, which means the inverter board is OK, power form rectifier bridge is not correct, check the bridge. (Same method as IGBT, disconnect the power, check those dioxides are damaged or not). 4. Usually if F1 exist when compressor start, the possible reason is main board. If F1 exist when fan start, it may be because of inverter board.
L0	Compressor inverter module failure	<ol style="list-style-type: none"> 1. to verify : 2. working pressures of the compressor 3. compressor winding resistances 4. U V W sequence between inverter board and compressor 5. sequence L1 L2 L3 between inverter board and filters board 6. inverter board
L1	Low voltage BUS protection of the inverter module	
L2	High voltage BUS protection of the inverter module	
L4	MCE protection	
L5	Speed protection 0	
L7	Phase sequence error	
L8	Compressor frequency variation greater than 15 Hz in 1 sec.	
L9	Compressor frequency difference with respect to target greater than 15 Hz	

Keys

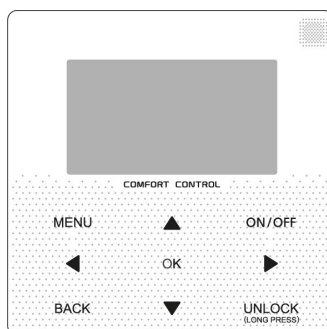

Keys	Function
MENU	Access to the menu structure (from the screen)
LEFT - RIGHT ◀▶ UP DOWN ▲▼	Moving the cursor on the display Movement within the menu structure Adjustment of parameter settings
ON/OFF	Turn on/off the space heating/cooling operation or DHW mode Turn on/or off functions in the menu structure Activation / deactivation of functions in the menu structure
BACK	Come back to the up level
UNLOCK	(Long press) Unlock / lock the control unit Unlocking / locking certain functions, such as the domestic hot water temperature control
OK	Hourly programming progress in the menu structure, confirmation of selections or access to submenus

Auto-restart function

The unit is equipped with an auto-restart function: in the event of a power failure (eg. black-out), when this is restored the unit restarts at the last settings selected.

11 CONTROLLER USER MANUAL



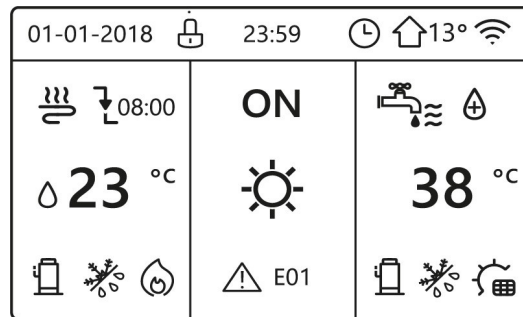









Meaning of icons









	Key lock		The compressor is activated
	At the next scheduled action, the temperature will decrease		Pump active
	The temperature not change		Weekly schedule
	The temperature will decrease		Time schedule
	The temperature will increase		Outdoor temperature
	Fan coil		Wi-Fi
	Radiator		Domestic hot water (DHS)
	Floor heating (radiant panels)		Disinfect function (anti-legionella) active
	System water supply temperature (configurable)	ON OFF	Switch on Switch off
	Ambient temperature set		DHW storage temperature
	Heating mode		Active solar panel
	Cooling mode		Active storage tank electric heater
	Automatic mode		Alarm
	Additional heat source		Smart grid mode
	Electric heater		

11 CONTROLLER USER MANUAL

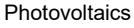
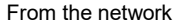
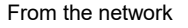
Anti-freeze mode active 	Defrosting mode active 	Away / at home holiday active 	Silent mode active 	ECO mode active 
--	---	--	---	--

	Fan coil 	Radiator 	Radiant panels 	DHW 
ON				
OFF				

Energy cost	Free 	Low 	High 
Smart grid	Photovoltaics 	From the network 	From the network 
Energy absorbed	Average 	Average 	Peak 

Home pages

When you turn on the wired controller, the system will enter the language selection page, You can choose your preferred language, then press OK to enter the home pages.

If you don't press OK in 60 seconds, the system will enter in the currently selected language.



Depending on the system layout, the following home pages may be possible:

- Desired ambient temperature
- Desired water flow temperature
- Actual temperature of the domestic hot water tank (DHW)

Type 1 system diagram

The system includes the floor heating and domestic hot water function.

Type 1 home page appears

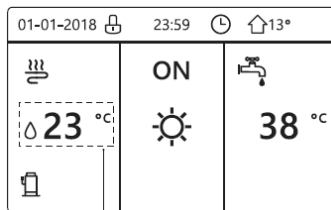

23°C= desired water flow temperature

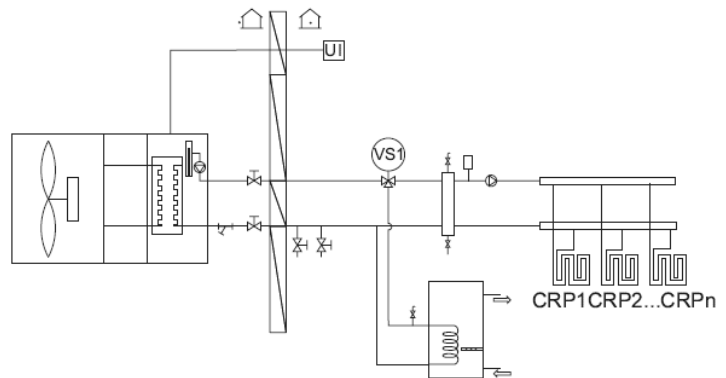

SERVICEMAN menu

Temp type setting

Temp. Water flow YES

Temp. Environment NO

Type 2 system diagram

The system includes the floor heating and domestic hot water function.
Type 2 home page appears

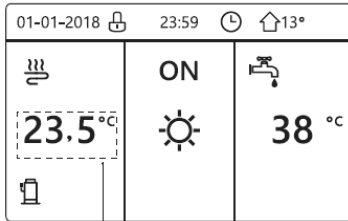

23,5°C= desired ambient temperature

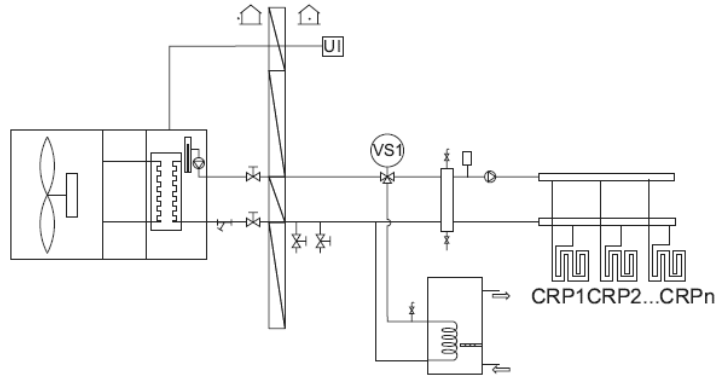

SERVICEMAN menu

Temp type setting

Temp. Water flow NO

Ambient Temp. YES

NOTE

It is necessary to install the wall-mounted control unit in the floor heating room to make it possible to control ambient temperature.

Type 3 system diagram

The system provides floor heating and ambient heating for the fan coil unit.
There is a main page and an additional one.

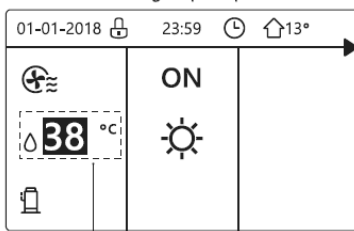

38°C= desired water flow temperature zone 1

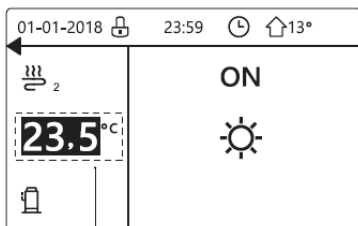

23,5°C= desired ambient temperature in zone 2

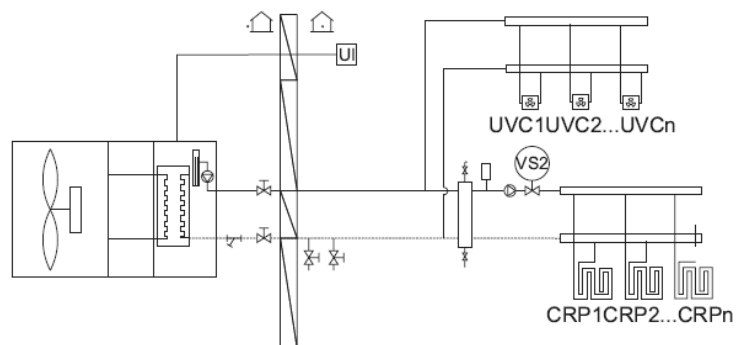

SERVICEMAN menu

Temp type setting

Temp. Water flow YES

DHW mode setting

DHW mode NO

11 CONTROLLER USER MANUAL

Type 4 system diagram

The system includes the cooling, ambient cooling function for the fan coil unit and domestic hot water. There is a main page and an additional one.

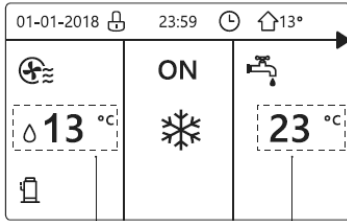

13°C= desired water flow temperature zone 1
23°C= actual DHW tank temperature

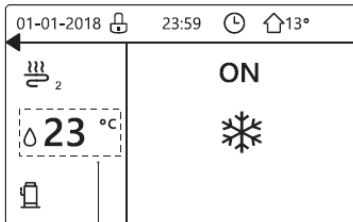

23°C= desired water flow temperature zone 2

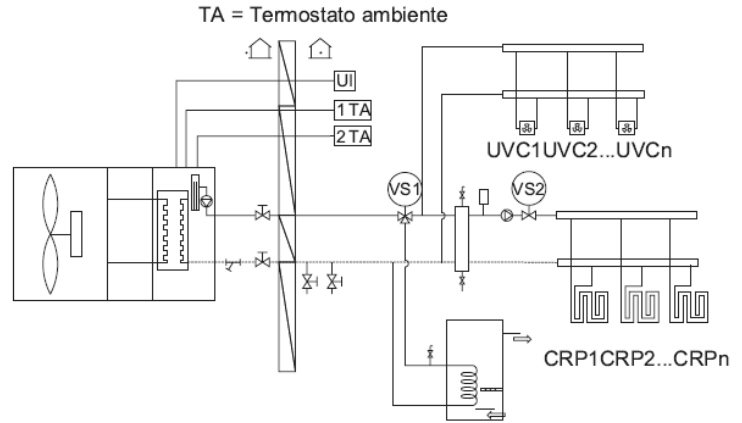

SERVICEMAN menu
Ambient thermostat
TWO ZONES YES

Menu structure

From a home page press MENU
To move use UP and DOWN

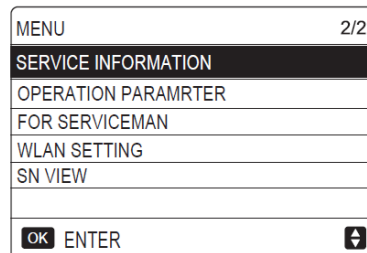
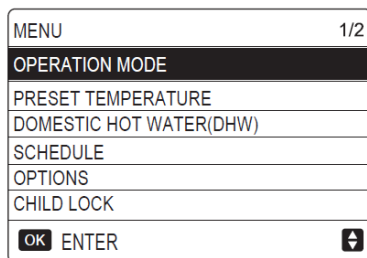

Structure menu

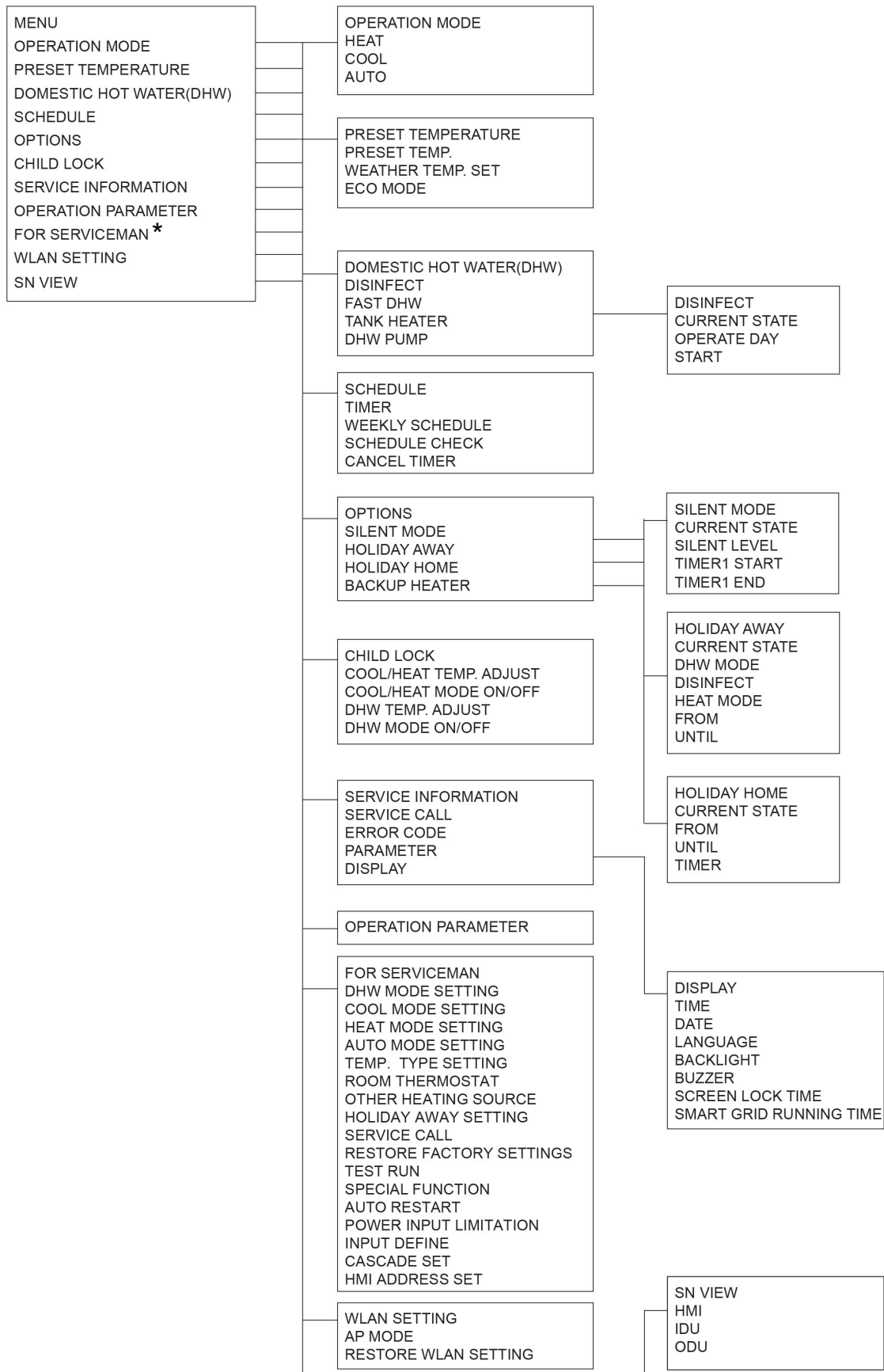

* Access by pwd is reserved to qualified personnel; The parameters changes may cause malfunctions.

Lock - unlock keyboard

If the UNLOCK icon is on the screen, the controller is locked. The following page appears

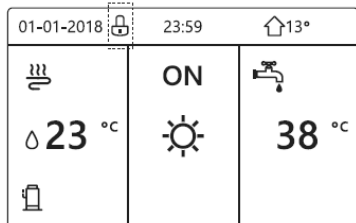

Press any key, the UNLOCK icon will flash. Long press the "UNLOCK" key. The icon will disappear, the interface can be checked. The interface will be locked if there is no handling for a long time (about 120 seconds: it can be set by the interface, see SERVICE INFORMATION).

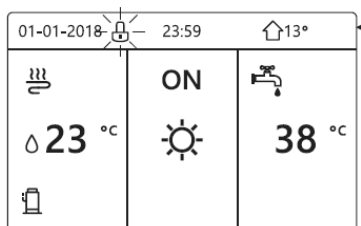

If the interface is unlocked, press and hold UNLOCK to lock it.

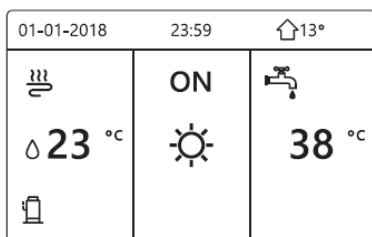

Long press UNLOCK Long press UNLOCK

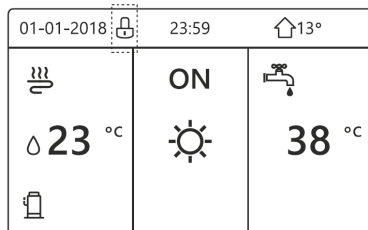

On - Off

Use the UNIT INTERFACE.

It is possible to control the activation / deactivation of the unit via the interface if AMBIENT THERMOSTAT = NO. Press LEFT and UP on the home page, the black cursor appears.

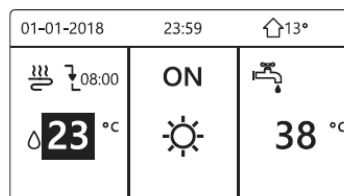

When the cursor is on the temperature of the side of the ambient operating mode (which provides for HEAT mode, COOL mode, AUTO mode), press ON-OFF to activate / deactivate space heating or cooling.

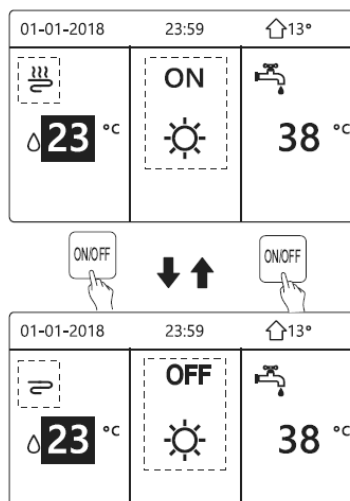

If DHW TYPE = NO, the following pages are displayed:

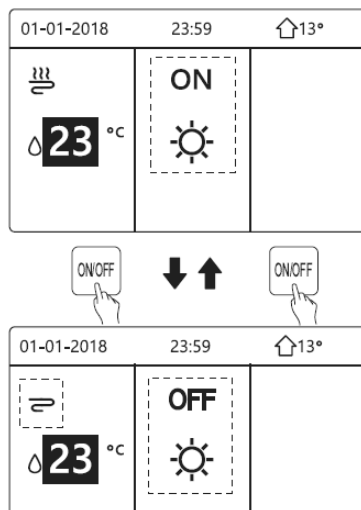

If TYPE TEMP = AMBIENT TEMP. , the following pages are displayed:

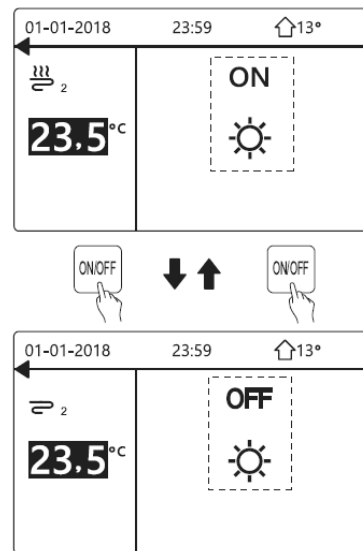
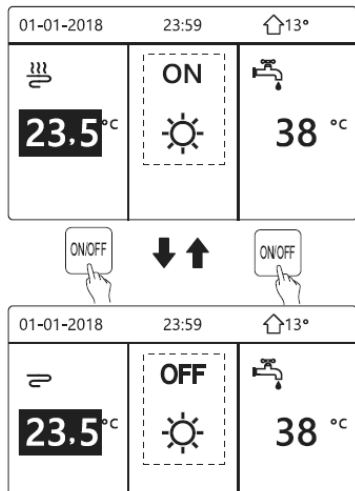

Use the AMBIENT THERMOSTAT.

1 - AMBIENT THERMOSTAT = NO.

Press LEFT and UP on the home page, the black cursor appears.

Press ON-OFF, the following page is displayed:

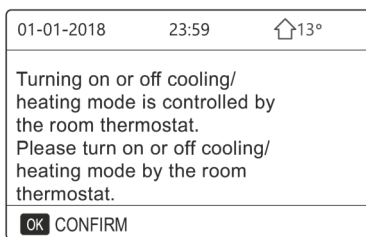

2 - AMBIENT THERMOSTAT = TWO ZONES

The ambient thermostat for the fan coil unit is deactivated, the ambient thermostat for underfloor heating is active and the unit is in operation, but the display is off.

The following page is displayed:

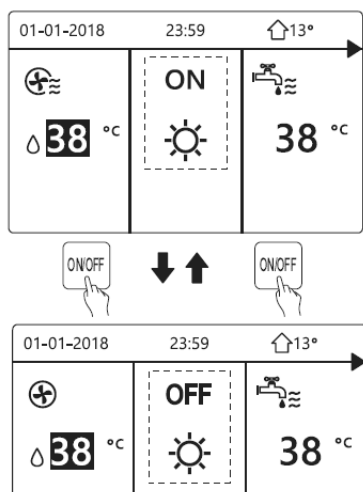

Use the interface to activate / deactivate the unit for the DHS. Press RIGHT and DOWN on the home page, the black cursor appears:

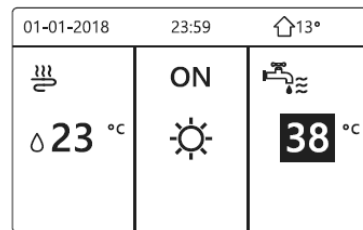

When the cursor is on the DHW mode temperature, press ON -OFF to activate / deactivate it.

If the ambient operation mode is activated (ON), the following pages are displayed:

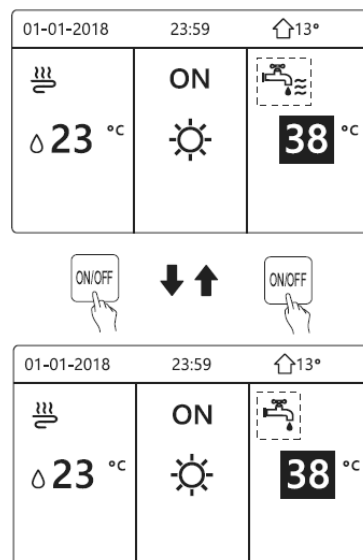

11 CONTROLLER USER MANUAL

If the ambient operation mode is deactivated (OFF), the following pages are displayed:

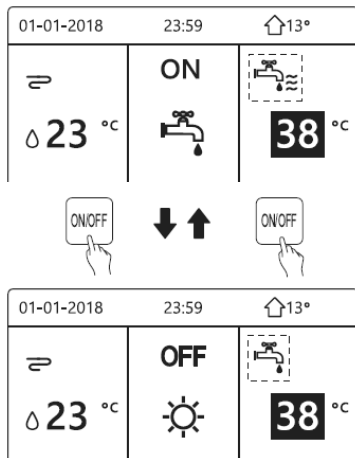

Adjusting the temperature

Press LEFT and UP on the home page, the black cursor appears.
If the cursor is on the temperature, use LEFT and RIGHT to select and use UP and DOWN to adjust the temperature.

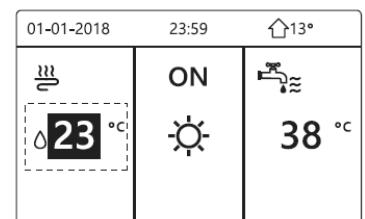
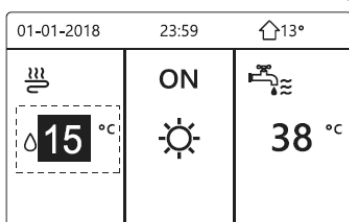
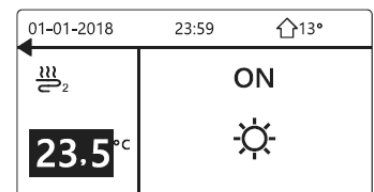
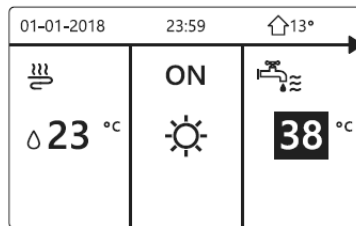
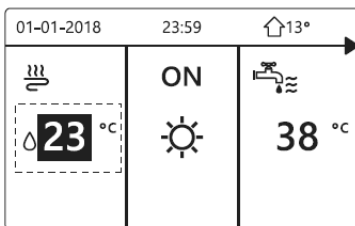
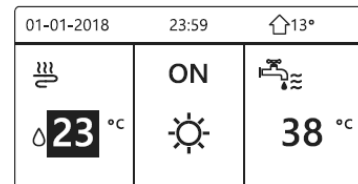

Ambient operating mode adjustment

Via INTERFACE.

Go to MENU > OPERATION MODE - OK
The following page is displayed:

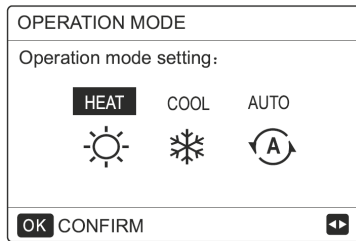

It is possible to select three modes: HEAT mode, COOL mode, AUTO mode.

Use LEFT and RIGHT to scroll, press OK to select.

If you do not press OK and exit the page using the BACK button, the mode remains active if the cursor has been moved to operating mode.

If only the HEAT (COOL) mode is available, the following page is displayed and the operation mode cannot be changed.

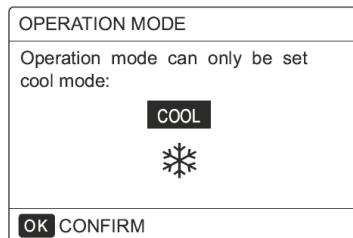
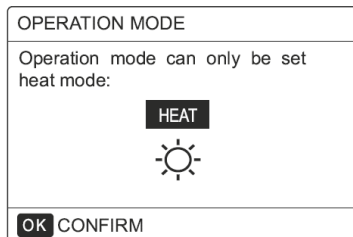

If you select	The ambient operating mode will be:
HEAT	Always HEAT mode
COOL	Always COOL mode
AUTO	Automatic modification of the setting via software based on external temperature (and the external temperature settings configured by the installer) and according to monthly limitations. Automatic modification is only possible under certain conditions

Via AMBIENT THERMOSTAT.

Go to MENU > OPERATION MODE.
If you press any key, the following page is displayed:

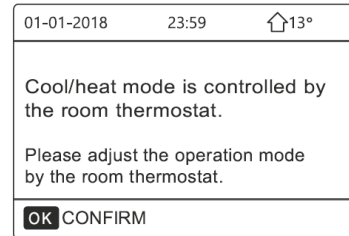

Default temperatures

The DEFAULT TEMP. function allows you to set a different temperature at a different time when the HEAT or COOL mode is active.

The function is disabled under these conditions:

- AUTO mode is active
- TIMER or WEEKLY PROGRAM Are running

Set:

MENU> DEFAULT TEMPERATURE> DEFAULT TEMP. = OK

The following page is displayed:

PRESET TEMPERATURE			1/2
PRESET TEMP.	WEATHER TEMP.SET	ECO MODE	
NO.	TIME	TEMP.	
1	<input type="checkbox"/>	00:00 25°C	
2	<input type="checkbox"/>	00:00 25°C	
3	<input type="checkbox"/>	00:00 25°C	
			⏪ ⏩

PRESET TEMPERATURE			2/2
PRESET TEMP.	WEATHER TEMP.SET	ECO MODE	
NO.	TIME	TEMP.	
4	<input type="checkbox"/>	00:00 25°C	
5	<input type="checkbox"/>	00:00 25°C	
6	<input type="checkbox"/>	00:00 25°C	
			⏪ ⏩

When the TWO ZONED function is activated, DEFAULT TEMP. is active only for zone 1.

11 CONTROLLER USER MANUAL

Use LEFT RIGHT, UP and DOWN to scroll.
 Use UP and DOWN to adjust the time and temperature.
 When the cursor is as shown in the figure, press OK.
 Timer 1 is selected.
 Press OK again, timer 1 is deselected.

PRESET TEMPERATURE 1/2		
PRESET TEMP.	WEATHER TEMP.SET	ECO MODE
NO.	TIME	TEMP.
1	00:00	25°C
2	00:00	25°C
3	00:00	25°C
OK <input checked="" type="checkbox"/> SELECT		

PRESET TEMPERATURE 1/2		
PRESET TEMP.	WEATHER TEMP.SET	ECO MODE
NO.	TIME	TEMP.
1	08:00	35°C
2	12:00	25°C
3	15:00	35°C
OK <input type="checkbox"/> CANCEL		

Use LEFT RIGHT, UP and DOWN to scroll.
 Use UP and DOWN to adjust the time and temperature.
 Six periods and six temperatures can be set.
 For example: Now time is 8.00 and temperature is 30°C.
 Let's set the DEFAULT TEMP.as in the table below.
 The following page is displayed:

01-01-2018 8:00 13°

08:00

25 °C

ON

NO.	TIME	TEMPER
1	8:00	35°C
2	12:00	25°C
3	15:00	35°C
4	18:00	25°C
5	20:00	35°C
6	23:00	25°C

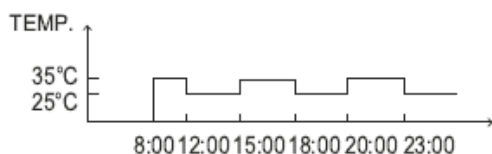

INFORMATION

When the ambient operation mode is changed, DEFAULT TEMP. switches off automatically.
 It is possible to use the DEFAULT TEMP function in HEAT or COOL mode. However, if the operating mode is changed, the DEFAULT TEMP function must be reset again .
 The current temperature is not valid when the unit is turned OFF. It activates at the next default temperature when the unit turns on again.

Weather temperature set

The SET CLIM. TEMP. function Allows you to preset the desired water flow temperature based on the outdoor air temperature.
 When the weather is warmer, the heating decreases.
 To save energy, the desired water flow temperature is decreased when the outdoor temperature increases and the HEAT mode is active.
 MENU> DEFAULT TEMPERATURES> SET CLIM. TEMP. >
 Press OK.
 The following page is displayed:

PRESET TEMPERATURE		
PRESET TEMP.	WEATHER TEMP.SET	ECO MODE
ZONE1 C-MODE LOW TEMP.		OFF
ZONE1 H-MODE LOW TEMP.		OFF
ZONE2 C-MODE LOW TEMP.		OFF
ZONE2 H-MODE LOW TEMP.		OFF
ON/OFF		ON/OFF

INFORMATION

SET. TEMP CLIM. has four types of curves:

1. high temperature curve for heating
2. low temperature curve for heating
3. high temperature curve for cooling
4. low temperature curve for cooling

If the high temperature for heating is set:
 it only has the high temperature setting curve for heating.

If the low temperature for heating is set:
 it only has the low temperature setting curve for heating.

And so on.

See the FOR SERVICEMAN > COOL MODE / HEAT MODE SETTING

The desired temperature T1S cannot be adjusted when the temperature curve is set to ON.

To use the HEAT mode in zone 1, select LOW HOT MODE ZONE 1 TEMP.

To use the COOL mode in zone 1 select LOW COLD MODE ZONE 1 TEMP.

If ON is selected, the following page is displayed:

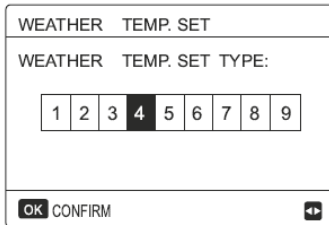

Use LEFT RIGHT to scroll.
Press OK to select.

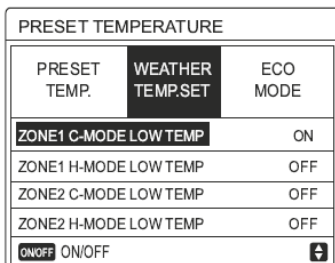

If the CLIM. TEMP SET. is activated, it is not possible to adjust the desired temperature on the interface.
Press UP DOWN to adjust the temperature on the home page.

The following page is displayed:

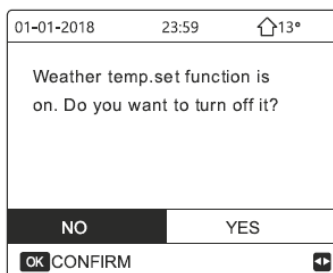

Move to NO, press OK to return to the home page Move to YES, press OK to restore CLIM. TEMP SET.

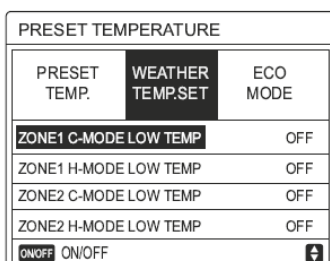

ECO mode

ECO mode saves energy.

MENU > PRESET TEMPERATURE > ECO MODE > Press OK.

The following page is displayed:

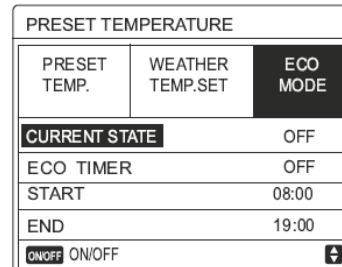

Press ON/OFF.

The following page is displayed:

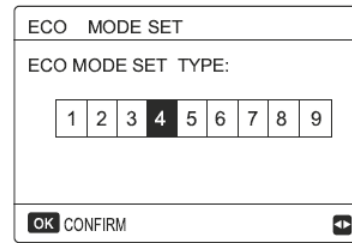

Use LEFT RIGHT to scroll.
Press OK to select.

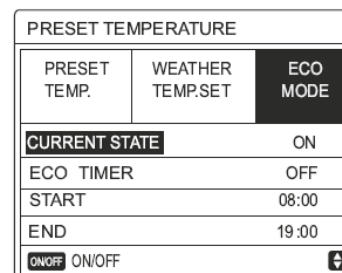

Use ON-OFF to activate / deactivate; use UP and DOWN to scroll.

When the cursor is on START or END, you can use LEFT RIGHT UP DOWN to scroll and UP DOWN to adjust the time.

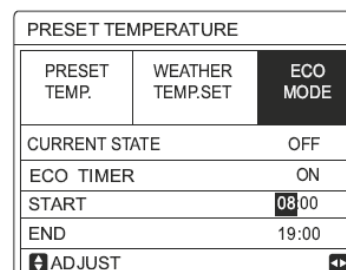

INFORMATION

SET. ECO MODE has two types of curves:

1. the high temperature setting curve for heating
2. the low temperature setting curve for heating

If the high temperature for heating is set:

it only has the high temperature setting curve for heating.

If the low temperature for heating is set:

it only has the low temperature setting curve for heating.

See the FOR SERVICEMAN > HEAT MODE SETTING

It is not possible to adjust the desired temperature T1S when the ECO mode is activated (ON)

It is possible to select the low or high temperature setting for heating: see table 1-2.

If ECO MODE is active (ON) and ECO TIMER is deactivated (OFF), the unit always operates in ECO mode.



If ECO MODE is active (ON) and ECO TIMER is activated (ON), the unit operates in ECO mode according to the start and end times.

DOMESTIC HOT WATER (DHW)			
DIS-INFECT	FAST DHW	TANK HEATER	DHW PUMP
CURRENT STATE			OFF
OPERATE DAY			FRI
START			23:00
ON/OFF ON/OFF			

Use LEFT RIGHT and UP DOWN to scroll and use UP DOWN to adjust the parameters when setting OPERATION DAY and START.

If the OPERATION DAY is set to FRIDAY AND START is set to 23:00, the disinfect function is activated on Friday, at 23:00.

If the disinfect function is active, the following page is displayed:

01-01-2018 23:59 13°		
	ON	
23.5 °C		38 °C

Domestic hot water (DHW)

Il modo ACS include i seguenti elementi:

1. **Disinfect**
2. **FAST DHW**
3. **Heated Tank**
4. **DHW pump**

Disinfect

The DISINFECT function allows you to eliminate Legionella bacteria.

In the disinfect function, the tank temperature reaches 65-70°C.

The disinfect temperature is set in DHW MODE.

See FOR SERVICEMAN. > DHW MODE > DISINFECT.

MENU > DOMESTIC HOT WATER > DISINFECT

Press OK. The following page is displayed:

DOMESTIC HOT WATER (DHW)			
DIS-INFECT	FAST DHW	TANK HEATER	DHW PUMP
CURRENT STATE			ON
OPERATE DAY			FRI
START			23:00
ON/OFF ON/OFF			



FAST DHW

The function allows you to force the system to activate DHW MODE.

The heat pump and the auxiliary or additional heater are activated together for the DHW MODE and the desired DHW temperature goes to 60 °C.

Select MENU> DOMESTIC HOT WATER> FAST DHW and press OK.

Use ON-OFF to select active (ON) or deactivated (OFF)

DOMESTIC HOT WATER (DHW)			
DIS-INFECT	FAST DHW	TANK HEATER	DHW PUMP
CURRENT STATE			ON
ON/OFF ON/OFF			



DOMESTIC HOT WATER (DHW)			
DIS-INFECT	FAST DHW	TANK HEATER	DHW PUMP
CURRENT STATE			OFF
ON/OFF ON/OFF			

INFORMATION

If CURRENT STATUS is deactivated (OFF), the FAST DHW function is not valid, while if it is active (ON) the FAST DHW function is active.

The FAST DHW function is activated once.

Tank heater

This function allows you to force heating of the water in the tank.

In the same situation, cooling or heating is required and the heat pump system is operating to produce cooling or heating. However, hot water is also required.

Furthermore, if the heat pump system is not sufficient, TANK HEATING can be used to heat the water in the tank.

Select MENU> DOMESTIC HOT WATER> TANK HEATER, press OK.

DOMESTIC HOT WATER (DHW)			
DIS-INFECT	FAST DHW	TANK HEATER	DHW PUMP
CURRENT STATE			ON
ON/OFF ON/OFF			



DOMESTIC HOT WATER (DHW)			
DIS-INFECT	FAST DHW	TANK HEATER	DHW PUMP
CURRENT STATE			OFF
ON/OFF ON/OFF			

Use ON-OFF to select active (ON) or deactivated (OFF), BACK to exit.

If TANK HEATER is active, the following page is displayed:

01-01-2018		23:59	↑ 13°
☁	ON	☀	
23 °C	☀	38 °C	
			☀

INFORMATION

If CURRENT STATUS is deactivated (OFF), TANK HEATER cannot be activated.

If the T5 tank sensor is in failure, the tank heater cannot work.

DHW pump

The function allows you to return the water to the water supply. Select MENU> DOMESTIC HOT WATER> DHW PUMP, press OK.

DOMESTIC HOT WATER (DHW) 1/2			
DIS-INFECT	FAST DHW	TANK HEATER	DHW PUMP
NO.	START	NO.	START
T1 <input type="checkbox"/>	00:00	T4 <input type="checkbox"/>	00:00
T2 <input type="checkbox"/>	00:00	T5 <input type="checkbox"/>	00:00
T3 <input type="checkbox"/>	00:00	T6 <input type="checkbox"/>	00:00

DOMESTIC HOT WATER (DHW) 2/2			
DIS-INFECT	FAST DHW	TANK HEATER	DHW PUMP
NO.	START	NO.	START
T7 <input type="checkbox"/>	00:00	T10 <input type="checkbox"/>	00:00
T8 <input type="checkbox"/>	00:00	T11 <input type="checkbox"/>	00:00
T9 <input type="checkbox"/>	00:00	T12 <input type="checkbox"/>	00:00

Move and press OK to select / deselect.

Use LEFT RIGHT and UP and DOWN to scroll and use UP and DOWN to adjust the parameters.

DOMESTIC HOT WATER (DHW) 1/2			
DIS-INFECT	FAST DHW	TANK HEATER	DHW PUMP
NO.	START	NO.	START
T1 <input checked="" type="checkbox"/>	00:00	T4 <input type="checkbox"/>	00:00
T2 <input type="checkbox"/>	00:00	T5 <input type="checkbox"/>	00:00
T3 <input type="checkbox"/>	00:00	T6 <input type="checkbox"/>	00:00

Example: the parameter relating to the DHW PUMP has been set (see FOR THE AFTER-SALES SERVICE> DHW MODE SETTING).

PUMP ACTIVATION TIME is 30 minutes.

11 CONTROLLER USER MANUAL

The setting is the following:

NO.	START
1	6:00
2	7:00
3	8:00
4	9:00

The PUMP activates as follows:

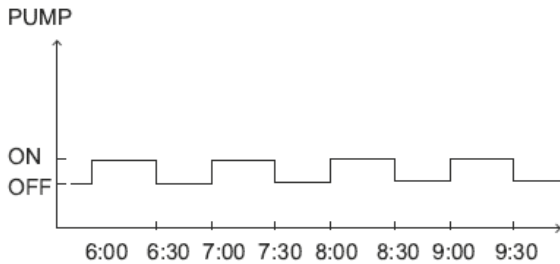

Time schedule

The PROGRAM menu. includes the following elements:

1. **TIMER**
2. **PROGRAM. WEEKLY .**
3. **CONTR. PROGRAM.**
4. **CANCEL TIMER**

TIMER

If the weekly schedule is active and the timer function is deactivated, the most recent setting is valid.

If the timer is activated, the timer icon appears on the home page.

SCHEDULE					1/2
TIMER	WEEKLY SCHEDULE	SCHEDULE CHECK	CANCEL TIMER		
NO.	START	END	MODE	TEMP	
1	<input type="checkbox"/>	00:00	00:00	HEAT	0°C
2	<input type="checkbox"/>	00:00	00:00	HEAT	0°C
3	<input type="checkbox"/>	00:00	00:00	HEAT	0°C

SCHEDULE					2/2
TIMER	WEEKLY SCHEDULE	SCHEDULE CHECK	CANCEL TIMER		
NO.	START	END	MODE	TEMP	
4	<input type="checkbox"/>	00:00	00:00	HEAT	0°C
5	<input type="checkbox"/>	00:00	00:00	HEAT	0°C
6	<input type="checkbox"/>	00:00	00:00	HEAT	0°C

Use LEFT RIGHT and UP DOWN to scroll and UP DOWN to adjust the time, mode and temperature

Use LEFT RIGHT and UP DOWN to scroll and UP DOWN to adjust the time, mode and temperature.

Move and press OK to select / deselect. 6 timers can be set.

To cancel the TIMER, move the cursor and press OK.

If the set start time is later than the end time (or if the temperature is not within mode range), the following page is displayed:

SCHEDULE			
TIMER	WEEKLY SCHEDULE	SCHEDULE CHECK	CANCEL TIMER
Timer1 is useless.			
Please check the timer setting and temperature setting.			
OK CONFIRM			

Example: 6 timers are set as follows.

The unit is activated as shown in figure

NO.	START	END	MODE	TEMP
T1	1: 00	3: 00	DHW	50°C
T2	7: 00	9: 00	HEAT	28°C
T3	11: 30	13: 00	COOL	20°C
T4	14: 00	16: 00	HEAT	28°C
T5	15: 00	19: 00	COOL	20°C
T6	18: 00	23: 30	DHW	50°C

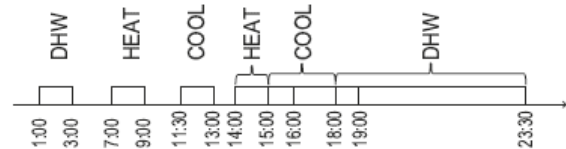

The control unit is activated as follows

TIME	The operatin of the controller
1: 00	DHW mode is turned ON
3: 00	DHW mode is turned OFF
7: 00	HEAT MODE is turned ON
9: 00	HEAT MODE is turned OFF
11: 30	COOL MODE is turned ON
13: 00	COOL MODE is turned OFF
14: 00	HEAT MODE is turned ON
15: 00	COOL MODE is turned ON and HEAT MODE is turned OFF
18: 00	DHW MODE is turned ON and COOL MODE is turned OFF
23: 30	DHW mode is turned OFF

INFORMATION

If the start and end times in a timer coincide, the timer is not valid.

Weekly schedule

If the timer function is on and the weekly schedule is off, the most recent setting is effective.

If the WEEKLY PROGRAM. is activated, the related icon appears on the home page.

Select MENU> PROGRAM. > WEEKLY PROGRAM .

Press OK

The following page is displayed

SCHEDULE						
TIMER	WEEKLY SCHEDULE	SCHEDULE CHECK	CANCLE TIMER			
MON.	TUE.	WED.	THU.	FRI.	SAT.	SUN.
<input checked="" type="checkbox"/>	<input type="checkbox"/>	<input type="checkbox"/>	<input type="checkbox"/>	<input type="checkbox"/>	<input type="checkbox"/>	<input type="checkbox"/>
ENTER		CANCEL				
OK MON SELECT						

First select the days of the week to be programmed.

Use LEFT and RIGHT to scroll, press OK to select / deselect the day.

INFORMATIN

It is necessary to set at least 2 days when the WEEKLY PROGRAM function is activated.

SCHEDULE						
TIMER	WEEKLY SCHEDULE	SCHEDULE CHECK	CANCLE TIMER			
MON.	TUE.	WED.	THU.	FRI.	SAT.	SUN.
<input type="checkbox"/>	<input type="checkbox"/>	<input type="checkbox"/>	<input type="checkbox"/>	<input checked="" type="checkbox"/>	<input type="checkbox"/>	<input type="checkbox"/>
ENTER		CANCEL				
OK MON SELECT						

Use LEFT RIGHT to set, press CONFIRM.

The days from Monday to Friday are selected, which have the same programming.

SCHEDULE						1/2
TIMER	WEEKLY SCHEDULE	SCHEDULE CHECK	CANCLE TIMER			
NO.	START	END	MODE	TEMP		
1	<input type="checkbox"/>	00:00	00:00	HEAT	0°C	
2	<input type="checkbox"/>	00:00	00:00	HEAT	0°C	
3	<input type="checkbox"/>	00:00	00:00	HEAT	0°C	

SCHEDULE						2/2
TIMER	WEEKLY SCHEDULE	SCHEDULE CHECK	CANCLE TIMER			
NO.	START	END	MODE	TEMP		
4	<input type="checkbox"/>	00:00	00:00	HEAT	0°C	
5	<input type="checkbox"/>	00:00	00:00	HEAT	0°C	
6	<input type="checkbox"/>	00:00	00:00	HEAT	0°C	

Use LEFT RIGHT and UP DOWN to scroll and adjust the time, mode and temperature.

It is possible to configure various timer settings, including start and end time, mode and temperature. HEAT mode, COOL mode and DHW mode are included.

The setting method refers to timer setting.

The end time must be later than the start time.

Otherwise, the TIMER NOT REQUIRED indication will appear, or it cannot be activated.

Programming control.

The CONTR. PROGRAM. function can only control the weekly schedule.

Select MENU> PROGRAM. > CONTR. PROGRAM.

Press OK

The following page is displayed:

Press UP DOWN, the timer from Monday to Sunday is displayed

SCHEDULE			
TIMER	WEEKLY SCHEDULE	SCHEDULE CHECK	CANCLE TIMER
WEEKLY SCHEDULE CHECK			
OK ENTER			

WEEKLY SCHEDULE CHECK					
DAY	NO	MODE	SET	START	END
MON	T1	<input type="checkbox"/>	HEAT	0°C	00:00 00:00
	T2	<input type="checkbox"/>	HEAT	0°C	00:00 00:00
	T3	<input type="checkbox"/>	HEAT	0°C	00:00 00:00
	T4	<input type="checkbox"/>	HEAT	0°C	00:00 00:00
	T5	<input type="checkbox"/>	HEAT	0°C	00:00 00:00
	T6	<input type="checkbox"/>	HEAT	0°C	00:00 00:00

Cancel timer

Select MENU> PROGRAM. > CANCEL TIMER.

Press OK

The following page is displayed:

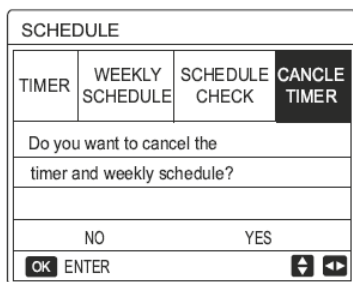

Use LEFT RIGHT and UP DOWN to move to YES, press OK to cancel the timer.

If you want to exit CANCEL TIMER, press "BACK".

If the TIMER or WEEKLY PROGRAM functions are active, the timer and weekly programming icon appear on the home page.

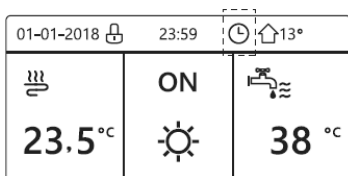

Use LEFT RIGHT and UP DOWN to move to YES, press OK to cancel the timer.

If you want to exit CANCEL TIMER, press "BACK".

If you cancel TIMER or PROGRAM. WEEKLY. The icons disappear from the main page

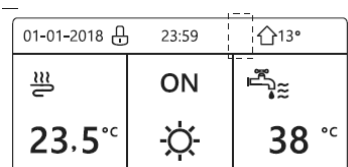

INFORMATION

WEEKLY TIMER / PROGRAM must be reset If you switch from the TEMP. WATER FLOW TEMP. to AMBIENT TEMP. or vice versa.

TIMER or WEEKLY PROGRAM. they are not valid if AMBIENT THERMOSTAT is active.

INFORMATION

- ECO MODE and COMFORT MODE have the highest priority, TIMER or WEEKLY PROGRAM . have an intermediate priority and DEFAULT TEMP. or CLIM. TEMP. SET. have the lowest priority.
- DEFAULT TEMP or CLIM. TEMP. SET. are no longer valid when setting ECO or COMFORT activation. DEFAULT TEMP or CLIM. TEMP. SET. must be reset when you deactivate ECO or COMFORT.

- TIMER or WEEKLY PROGRAM. they are not valid when ECO or COMFORT are activated. TIMER or WEEKLY PROGRAM. . they are activated when ECO or COMFORT are not in operation.
- TIMER or WEEKLY PROGRAM. have the same priority. The function with the most recent setting is valid. DEFAULT TEMP. is no longer valid when TIMER or WEEKLY PROGRAM. have no effect on CLIM. TEMP. SET
- DEFAULT TEMP and CLIM. TEMP. have the same priority. The function with the most recent setting is valid

INFORMATION

It is possible to program all the elements (DEFAULT TEMP., ECO / COMFORT, DISINFECT, DHW PUMP, TIMER, WEEKLY PROGRAM. , SILENT MODE, HOLIDAY AT HOME) by setting the relative function to ON-OFF from the start time to the end time.

Options

The OPTIONS menu includes the following items:

1. SILENT MODE
2. HOLIDAY AWAY
3. HOLIDAY AT HOME
4. BACKUP HEATER

Silent mode

The silent mode allows you to reduce unit noise.

However, this also reduces the heating / cooling capacity of the system.

Silent mode has two levels:

Level 2 has is quieter and the heating / cooling capacity is also lower.

It is possible to use silent mode in the following ways:

1. Silent mode all the time
2. Silent mode based on timer.

Go to the home page to check if silent mode is active. If the related icon appears.

Select MENU> OPTIONS> SILENT MODE

Press OK

The following page is displayed:

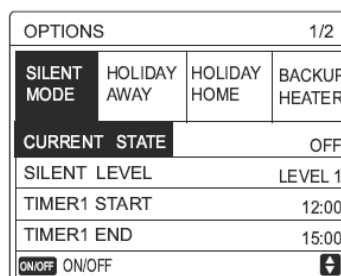

Use ON-OFF to select active (ON) or disabled (OFF).
If CURRENT STATUS is set to OFF, SILENT MODE is invalid.

When you select SILENCE LEVEL and press OK or RIGHT, the following page is displayed:

OPTIONS			
SILENT MODE	HOLIDAY AWAY	HOLIDAY HOME	BACKUP HEATER
CURRENT STATE			ON
SILENT LEVEL			LEVEL 1
TIMER1 START			12:00
TIMER1 END			15:00
ADJUST			

LEVEL 1

OPTIONS			
SILENT MODE	HOLIDAY AWAY	HOLIDAY HOME	BACKUP HEATER
CURRENT STATE			ON
SILENT LEVEL			LEVEL 2
TIMER1 START			12:00
TIMER1 END			15:00
ADJUST			

LEVEL 2

UP and DOWN can be used to select level 1 or level 2. Press OK.

If silent TIMER is selected, press OK to access.

The following page is displayed:

OPTIONS			
SILENT MODE	HOLIDAY AWAY	HOLIDAY HOME	BACKUP HEATER
TIMER1			OFF
TIMER2 START			22:00
TIMER2 END			07:00
TIMER2			OFF
ADJUST			

It is possible to set two timers.

Move and press OK to select / deselect.

If both timers are deselected, the silent mode always remains active.

Otherwise the operation takes place based on the time.

Holiday away.

If the Holiday away mode is active, the corresponding icon appears on the home page.

The Holiday away function allows you to keep the house from freezing in the winter when you are away for the holidays and to reactivate the unit before the end of the holidays.

Go to MENU > OPTIONS > HOLIDAY AWAY.

Press OK.

The following page is displayed:

OPTIONS			
SILENT MODE	HOLIDAY AWAY	HOLIDAY HOME	BACKUP HEATER
CURRENT STATE			OFF
DHW MODE			ON
DISINFECT			ON
HEAT MODE			ON
ON/OFF ON/OFF			

OPTIONS			
SILENT MODE	HOLIDAY AWAY	HOLIDAY HOME	BACKUP HEATER
FROM			00-00-2000
UNTIL			00-00-2000
ADJUST			

Example:

- in two days we leave for 2 weeks during the winter.
- today is 31/01/18 and 02/02/18 the holidays begin.
- you want to save energy, but to make sure the house does not freeze.

Go to MENU > OPTIONS > HOLIDAY AWAY.

Press OK.

Use ON-OFF to select activated (ON), deactivated (OFF) and use LEFT RIGHT UP DOWN to scroll and adjust,

Setting	Value
Holiday away	ON
From	2 February 2018
Until	16 February 2018
Operation mode	Heating
disinfect	ON

INFORMATION

- If the DHW mode is activated in the Holiday away mode, the disinfect function set by the user is not valid.
- If the holiday away mode is active, the timer and the weekly schedule are not valid unless the mode is deactivated.
- If CURRENT STATUS is deactivated (OFF), HOLIDAY AWAY is disabled (OFF).
- If CURRENT STATUS is activated (ON), HOLIDAY AWAY is activated (ON).

INFORMATION

- The remote control does not accept commands when holiday away mode is active (ON).
- Unit disinfecting is completed at 23:00 on the last day, if the related function is activated.
- When the Holiday away mode is active, the previously set climatic curves are invalid and will automatically take effect at the end of the set away Holiday period.
- The default temperature is not valid when Holiday away mode is active, but the default value still appears on the main page.

Holiday at home

The holiday at home function allows you to apply changes to normal schedules without having to change them when you spend your holidays at home,

Period	Then...
Before and after your holiday	Your normal schedules will be used.
During your holiday	The configured holiday settings will be used.

If Holiday at home mode is active, the home icon appears on the home page.

Select MENU> OPTIONS> HOLIDAY AT HOME

Press OK.

The following page is displayed:

OPTIONS			
SILENT MODE	HOLIDAY AWAY	HOLIDAY HOME	BACKUP HEATER
CURRENT STATE			OFF
FROM		00-00-2000	
UNTIL		00-00-2000	
TIMER		ENTER	
ON/OFF		ON/OFF	

Use ON-OFF to select active (ON) or disabled (OFF) and use LEFT RIGHT UP DOWN to scroll and adjust.

If CURRENT STATUS is deactivated (OFF), HOLIDAY AT HOME is deactivated (OFF).

If CURRENT STATUS is active (ON), HOLIDAY HOME is activated (ON).

Use UP DOWN to adjust the date.

- Before and after the holiday, normal schedule will be active.
- During the holiday, you save energy and prevent the house from freezing.

INFORMATION

It is necessary to restore Holiday away or Holiday at home if the operating mode of the unit is changed.

Backup heater.

The function allows you to force activation of the backup heater.

Go to MENU > OPTIONS > BACKUP HEATER.

Press OK.

If IBH and AHS are not set as valid by the DIP switch on the main control panel of the hydraulic module, the following page is displayed:

OPTIONS			
SILENT MODE	HOLIDAY AWAY	HOLIDAY HOME	BACKUP HEATER

IBH: backup heater for indoor unit

AHS= Additional heating source

If IBH and AHS are set as valid, the following page is displayed:

OPTIONS			
SILENT MODE	HOLIDAY AWAY	HOLIDAY HOME	BACKUP HEATER
BACKUP HEATER			ON
ON/OFF		ON/OFF	

Use ON-OFF to select active (ON), deactivated (OFF)

INFORMATION

- If automatic operation mode is set on the ambient heating or cooling side, the backup heater function cannot be selected.
- The BACKUP HEAT function is not valid when only the AMBIENT HEAT MODE is active.

Child lock

This function allows you to prevent children from using the unit incorrectly.

It is possible to lock or unlock the setting of the modes and control temperature regulation using the CHILD LOCK function.

Select MENU> CHILD LOCK.

The following page is displayed:

Enter your current password.

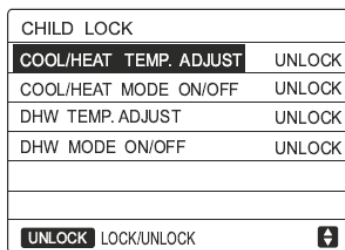
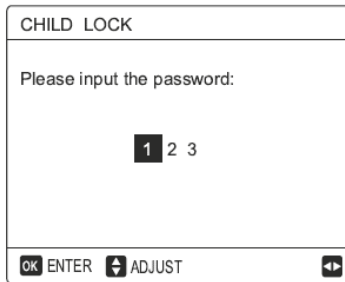

Use UP DOWN to scroll and ON-OFF to select LOCK, UNLOCK.

It is not possible to adjust the cooling / heating temperature when the TEMP ADJ. COOL / HEAT is locked.

If you want to adjust the cooling / heating temperature when it is locked, the following page is displayed:

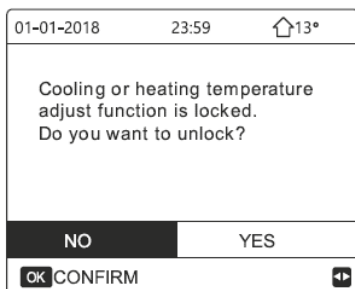

It is not possible to activate or deactivate ON / OFF COOL / HEAT MODE when the function is blocked.

If you want to activate or deactivate COOL / HEAT MODE ON-OFF when the function is locked, the following page is displayed:

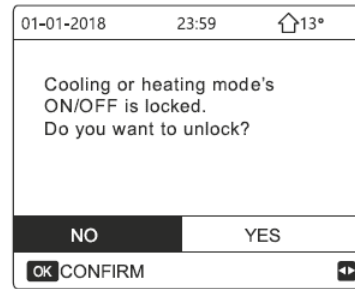

It is not possible to adjust DHW temperature when the DHW TEMP ADJ. is locked.

If you want to adjust DHW temperature when the DHW TEMP ADJ. is locked, the following page is displayed:

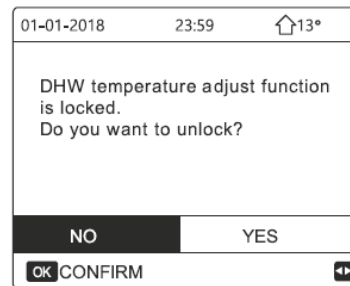

It is not possible to activate or deactivate the DHW mode when the ON-OFF DHW MODE function is locked.

If you want to activate or deactivate the DHW mode when the DHW MODE ON-OFF function is locked, the following page is displayed:

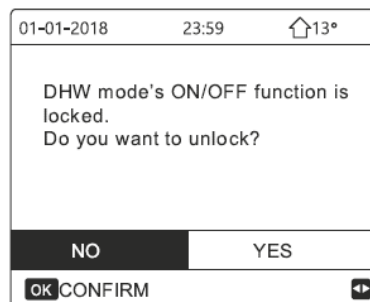

Service information.

The menu includes the following items:

1. SERVICE CALL
2. ERROR CODE
3. PARAMETERS
4. VIEW

How to access the menu

How to access the menu

Select MENU> SERVICE INFORMATION.

Press OK

The following page is displayed:

Service call can contain a phone or mobile phone number.

The installer can enter a phone number.

See FOR SERVICEMAN.

SERVICE INFORMATION			
SERVICE CALL	ERROR CODE	PARAMETER	DISPLAY
PHONE NO.	0000000000000		
MOBILE NO.	0000000000000		
OK COMFIRM			

The error code indicates when a fault or problem occurs and shows the meaning of the error code.

Press OK and the following page is displayed.

SERVICE INFORMATION			
SERVICE CALL	ERROR CODE	PARAMETER	DISPLAY
E2	14:10		01-01-2018
E2	14:00		01-01-2018
E2	13:50		01-01-2018
E2	13:20		01-01-2018
OK ENTER			

SERVICE INFORMATION 1/2			
SERVICE CALL	ERROR CODE	PARAMETER	DISPLAY
E2	14:10		01-01-2018
E2	14:00		01-01-2018
E2	13:50		01-01-2018
E2	13:20		01-01-2018
OK ENTER			

Press OK to show the meaning of the error code.

SERVICE INFORMATION		
SERVICE CALL	ERROR CODE	PARAMETER
	E2	communication fault between controller and indoor unit
Please contact your dealer.		
OK COMFIRM		

INFORMATION

It is possible to record a maximum of 8 error codes

The parameter function allows you to view the main parameters.

Two parameter pages are available:

SERVICE INFORMATION 1/2			
SERVICE CALL	ERROR CODE	PARAMETER	DISPLAY
		ROOM SET TEMP.	26°C
		MAIN SET TEMP.	55°C
		TANK SET TEMP.	55°C
		ROOM ACTUAL TEMP.	24°C

SERVICE INFORMATION 2/2			
SERVICE CALL	ERROR CODE	PARAMETER	DISPLAY
		MAIN ACTUAL TEMP.	26°C
		TANK ACTUAL TEMP.	55°C
		SMART GRID RUNNING TIME	0 Hrs

The DISPLAY function is used to set the interface.

Use OK to access and LEFT RIGHT UP DOWN to scroll.

SERVICE INFORMATION 1/2			
SERVICE CALL	ERROR CODE	PARAMETER	DISPLAY
		TIME	12:30
		DATE	08-08-2018
		LANGUAGE	EN
		BACKLIGHT	ON
OK ENTER			

SERVICE INFORMATION 2/2			
SERVICE CALL	ERROR CODE	PARAMETER	DISPLAY
		BUZZER	ON
		SCREEN LOCK TIME	120SEC
		SMART GRID RUNNING TIME	2 Hrs
ON/OFF ON/OFF			

Operation Parameter

This menu is reserved for the installer or the service technician who checks the operating parameters.

Select MENU> OPERATING PARAMETERS

Press OK.

There are 6 pages relating to the operating parameters.

Use UP DOWN to scroll.

OPERATION PARAMETER	#01
ONLINE UNITS NUMBER	1
OPERATE MODE	COOL
SV1 STATE	ON
SV2 STATE	OFF
SV3 STATE	OFF
PUMP_I	ON
ADDRESS	1/9

OPERATION PARAMETER	#01
PUMP_O	OFF
PUMP_C	OFF
PUMP_S	OFF
PUMP_D	OFF
PIPE BACKUP HEATER	OFF
TANK BACKUP HEATER	ON
ADDRESS	2/9

OPERATION PARAMETER	#01
GAS BOILER	OFF
T1 LEAVING WATER TEMP.	35°C
WATER FLOW	1.72m ³ /h
HEAT PUMP CAPACTIY	11.52kW
POWER CONSUM	1000kWh
Ta ROOM TEMP.	25°C
ADDRESS	3/9

OPERATION PARAMETER	#01
T5 WATER TANK TEMP.	53°C
Tw2 CIRCUIT2 WATER TEMP.	35°C
TIS' C1 CLI. CURVE TEMP.	35°C
TIS2' C2 CLI. CURVE TEMP.	35°C
TW_O PLATE W-OUTLET TEMP.	35°C
TW_I PLATE W-INLET TEMP.	30°C
ADDRESS	4/9

OPERATION PARAMETER	#01
Tbt1 BUFFERTANK_UP TEMP.	35°C
Tbt2 BUFFERTANK_LOW TEMP.	35°C
Tsolar	25°C
IDU SOFTWARE	01-09-2019V01
ADDRESS	5/9

OPERATION PARAMETER	#01
ODU MODEL	6kW
COMP.CURRENT	12A
COMP.FREQUENCY	24Hz
COMP.RUN TIME	54 MIN
COMP.TOTAL RUN TIME	1000Hrs
EXPANSION VALVE	200P
ADDRESS	6/9

OPERATION PARAMETER	#01
FAN SPEED	600R/MIN
IDU TARGET FREQUENCY	46Hz
FREQUENCY LIMITED TYPE	5
SUPPLY VOLTAGE	230V
DC GENERATRIX VOLTAGE	420V
DC GENERATRIX CURRENT	18A
ADDRESS	7/9

OPERATION PARAMETER	#01
TW_O PLATE W-OUTLET TEMP.	35°C
TW_I PLATE W-INLET TEMP.	30°C
T2 PLATE F-OUT TEMP.	35°C
T2B PLATE F-IN TEMP.	35°C
Th COMP. SUCTION TEMP.	5°C
Tp COMP. DISCHARGE TEMP.	75°C
ADDRESS	8/9

OPERATION PARAMETER	#01
T3 OUTDOOR EXCHANGE TEMP.	5°C
T4 OUTDOOR AIR TEMP.	5°C
TF MODULE TEMP.	55°C
P1 COMP. PRESSURE	2300kPa
ODU SOFTWARE	01-09-2018V01
HMI SOFTWARE	01-09-2018V01
ADDRESS	9/9

INFORMATION

Entering the energy consumption parameter is optional.

Parameters not activated in the system are marked with "--".

The capacity of the heat pump is indicated only as a reference and should not be used to evaluate the unit efficiency.

Sensor accuracy is $\pm 1^\circ\text{C}$.

The flow rate parameters are calculated based on pump operating parameters.

The deviation changes according to flow speed.

The maximum deviation is 15%.

For the serviceman.

This menu is reserved for the installer or the service technician.
 Select MENU> FOR SERVICEMAN.
 Press OK.
 Home users must NOT change the settings using this menu.
 For this reason, a password has been set which prevents unauthorized access to the service settings.
 The password is 234

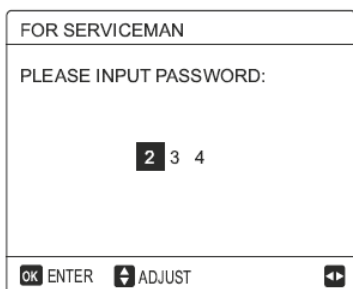

How to exit the FOR SERVICEMAN menu.

If all the parameters have been set, press BACK.
 The following page is displayed:

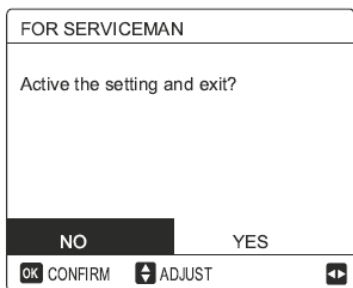

Select YES and press OK to exit the menu.
 After exiting the menu, the unit turns off.

Network configurations.

- The keyboard has an intelligent control system based on a built-in module, which receives control signal from the APP.
- Before connecting to the WLAN, check if your router is active and make sure that the control unit is connected correctly to receive the wireless signal.
- During the wireless connection process, the related icon flashes to indicate that network implementation is in progress.

At the end of the process, the icon always remains on.

Setting the wall control.

The parameters of the wall control include the settings for PA MODE and RESET WLAN SETTINGS.

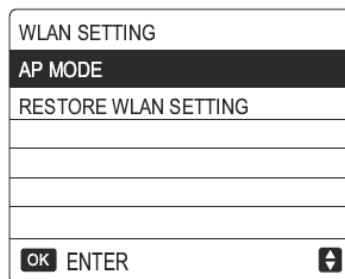

Activate the WLAN interface.
 Select MENU> WLAN SETUP> PA MODE
 Press OK.
 The following page is displayed:

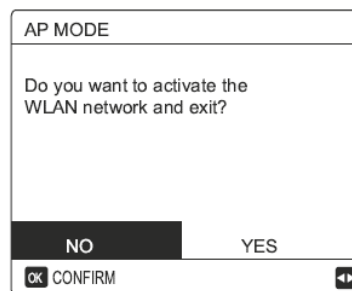

Use LEFT RIGHT to move to YES.
 Press "OK" to select PA MODE.
 Select the corresponding PA Mode on the mobile device and continue with subsequent settings based on APP instructions.

CAUTION

After accessing PA Mode, if connection with the mobile phone has not been established, the Wifi icon flashes for 10 minutes, then disappears.
 If connection with the mobile phone has been established, the icon is always displayed.

Reset the WLAN setting using the interface.
 Select MENU> WLAN SETUP> RESTORE WLAN SETTINGS.
 Press OK.
 The following page is displayed:

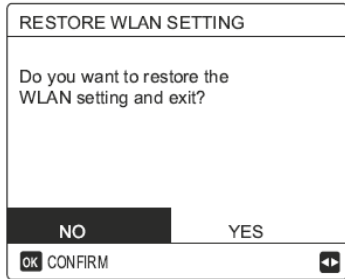

Use LEFT RIGHT to move to YES.
 Press OK to restore the WLAN setting.
 At this point, the wireless configuration has been restored.

Mobile device setting.

PA Mode is available for wireless connection at the mobile device level.

- The APP must be installed.
- Scan the following QR code to install the Smart Home APP or
- Search for MSmartLife in the APP store or
- GOOGLE PLAY to install the APP.

1. Log in / register
 Click on the + button on the right on the home page,
 register the account following the instructions in the guide.



Adding home equipment.

1. Choose the control unit model, then add the device
2. Configure the control unit following APP instructions.

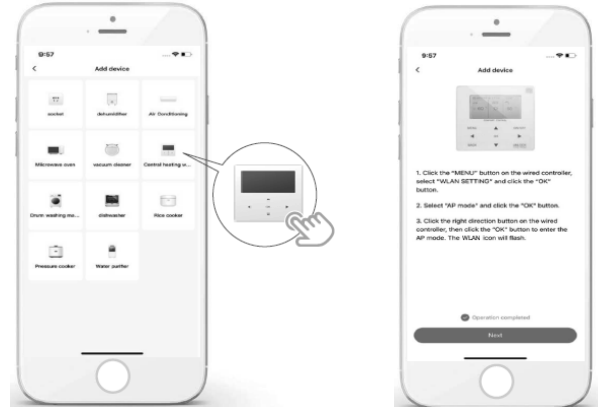

3. Wait for the home appliance to connect, then click on COMPLETE.
4. When the home appliance is connected, the WiFi icon of the control unit always remains on and it is possible to control the air conditioner via the APP.
5. If the network connection process fails or if you need to re-establish and replace the mobile connection, factory reset the WLAN on the control unit and then repeat the previous procedure.

WARNING

Troubleshooting for networking failures.

- When connecting the product to the network, make sure that the phone is in close proximity to the product.
- Currently only routers with 2.4 GHz band are supported.
- We do not recommend using special characters (punctuation marks, spaces, etc.) in the name of the WLAN.
- It is preferable not to connect more than 10 devices to a single router since home appliances are affected by weak or unstable signals.
- If you change the password of the router or WLAN, delete all the settings and reset the appliances.
- The contents of the APP may undergo changes as a result of version updates and in this case this will be based on actual operation.

SN view

SN VIEW
HMI NO. 0000C3111000H120F19A264001320000

SN VIEW	#1
IDU NO. 341140003929C26010005Z	
ODU NO. 31125300Y1286280400029	
	

12 CONTROLLER MENU

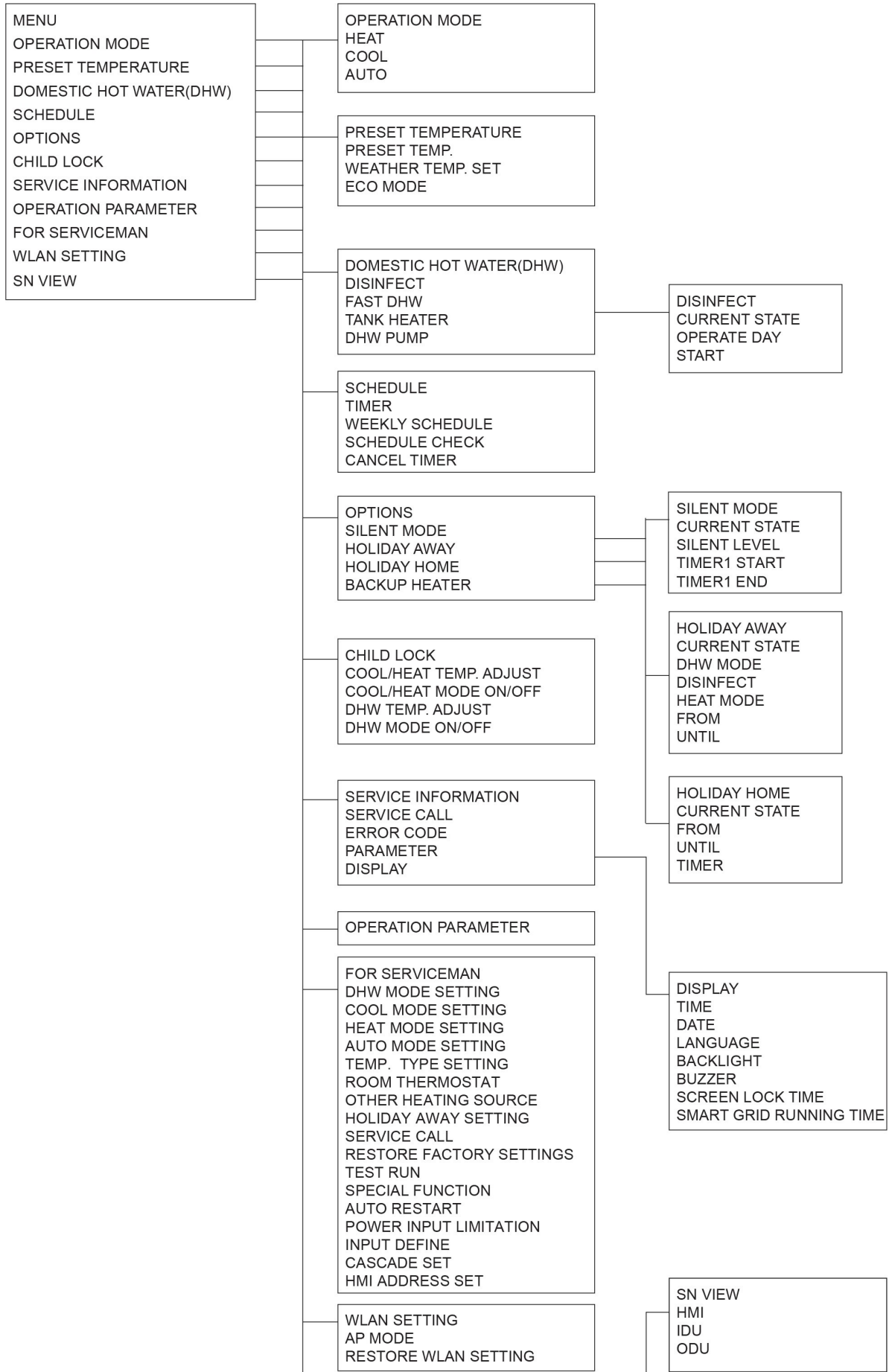

12 CONTROLLER MENU

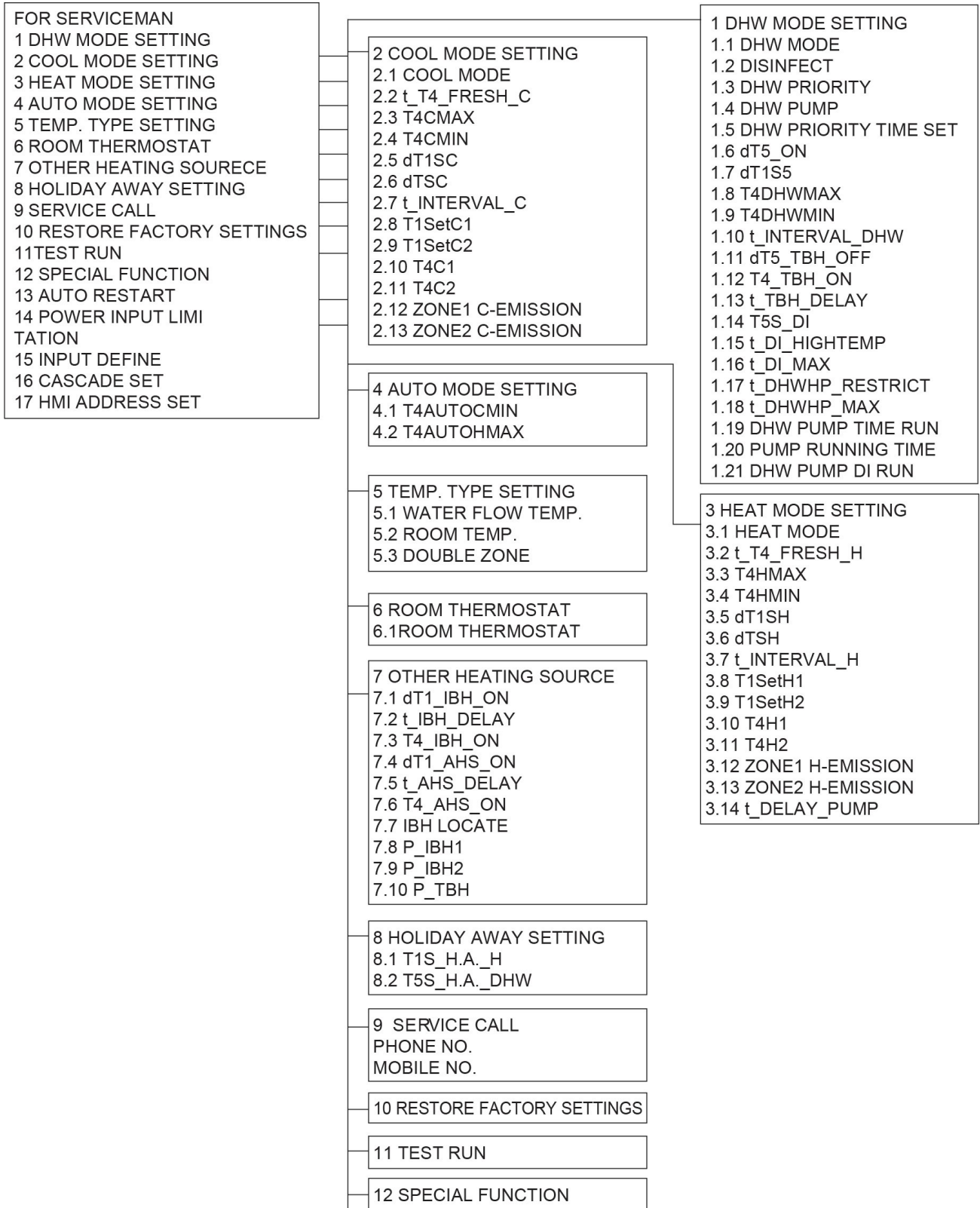

12 CONTROLLER MENU

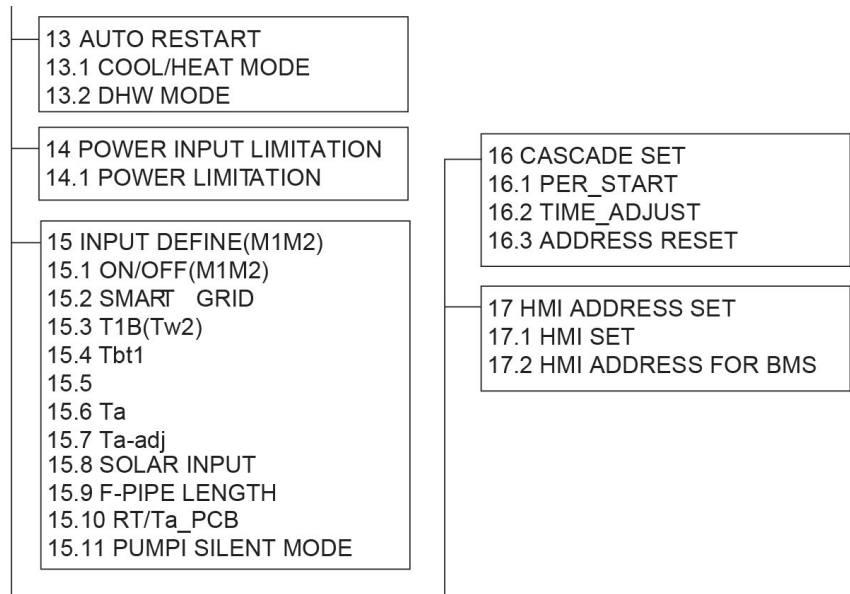

13 CASCADE OPERATION

Cascade operation allows up to 6 units to be connected in parallel, thereby ensuring that the system is fully reliable and efficient. The Master unit controls and displays the parameters of the entire system on its User Interface, activating the Slave units when its capacity is not enough to fulfil the system load.

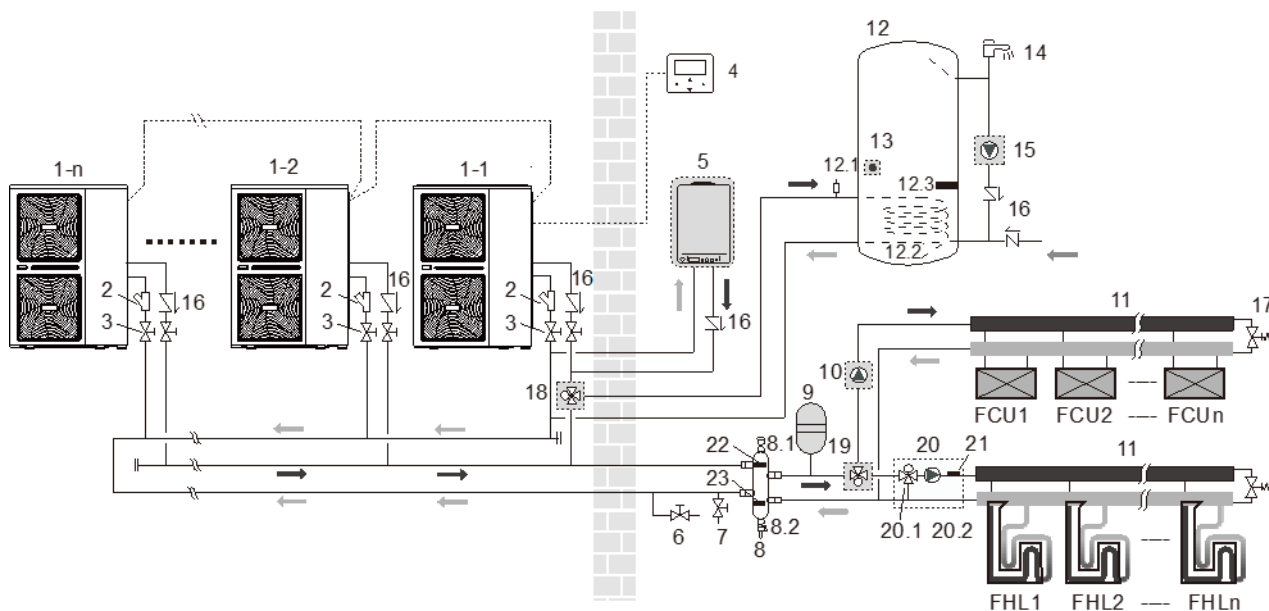

1-1	Master	12.3	Heating heater
1-n	Slave	13	T5: temperature probe
2	Filter	14	Hot water tap
3	Shut-off valve	15	P_d: domestic hot water pump
4	Controller	16	Non-return valve
5	Backup heater	17	Bypass valve
6	Drain	18	SV1: 3-way valve
7	Filling	19	SV1: 3-way valve
8	Balancing tank	20	Mixing unit
8.1	Vent	20.1	P_c: area 2 pump
8.2	Drain	20.2	SV3: 3-way valve
9	Expansion vessel	21	Tw2: area 2 temperature probe
10	P_o: external circulation pump	22	Tbt1: balancing tank temperature probe
11	Manifold	23	--
12	Domestic hot water tank	FHL	Underfloor heating
12.1	Vent	FCU	Fan coil
12.2	Exchanger		

Cooling, Heating and DHW logic

The unit's control system can monitor and display the operations of the whole system only by connecting the Master unit to the HMI user interface.

The Master unit can operate in Cooling / Heating / DHW / AUTO mode.

The Slave units can only work in Cooling / Heating mode.

In AUTO mode, the Master unit decides how to operate based on its T4 probe (room temperature) and transmits the signal to the Slave units.

The initial number of units is calculated according to two factors: the % of units that need to turn on (set on the HMI) multiplied by a coefficient based on the water delta T (set - output).

After a recurring period of time (set on the HMI), the Master unit activates or deactivates the Slave units according to a calculation carried out with the maximum temperature of the domestic hot water tank and the water temperature required in Heating / Cooling mode.

Every 10 seconds the Master unit sends a start signal to each Slave unit to be operated

Only the Master unit can connect to the domestic hot water boiler via a 3-way valve and control domestic hot water.

The 3-way valve and the DHW tank must be installed in the Master unit piping: do not install the 3-way valve and the DHW tank in the main pipe of the cascade system.

In case of a DHW request, the Master unit will operate in DHW mode, while at the same time the Slave units can operate in Heating or Cooling mode.

Once the DHW operation ends, the Master unit will go back to the Heating / Cooling mode.

Only the Master unit can connect to the AHS and control it (an auxiliary heating source such as a gas boiler).

Rotation and back-up.

The system counts the hours of operation of the compressor for all the units (including the main one).

When the system is started, the units with the shortest operating time have priority to start.

This way the system rotates the operation of all the units in order to ensure they are used evenly.

In the event of a unit malfunction, the Master unit is set up to activate the next one and ensure continuity of operation.

Note: the Master unit is included in the rotation logic, but cannot have a backup.

Defrosting

The defrosting logic is as follows:

1. all the units (Master + Slave) simultaneously in defrosting mode cannot be more than 50% of the units in operation
2. when a unit is defrosting (including the Master unit), no other units will start
3. if the Master unit is producing domestic hot water, it defrosts regularly as if it were not running in cascade: the Slave units continue the Heating operations with the logic reported in point 1

Examples

6-unit system, with 2 units running:

there can be up to 1 unit in defrosting mode at the same time.

When this unit has completed the defrosting stage, the next one starts defrosting

6-unit system, with 5 units running:

there can be up to 2 units in defrosting mode at the same time.

When these units have completed the defrosting stage, the next 2 start defrosting

Settings.

MENU > FOR SERVICEMAN > CASCADE SET

16 CASCADE SET	
16.1 PER_START	20%
16.2 TIME_ADJUST	5 MIN
16.3 ADDRESS RESET	00
[+] ADJUST	

PER_START

Sets the number of units that will start once the system has been started

Can be set from 10% to 100%. The percentage refers to the total number of units (Master + Slave units)

TIME_ADJUST

Sets the time after which the Master unit checks whether to activate or deactivate a Slave unit

Can be set from 0 to 60 min.

ADDRESS RESET

Sets the address code of a Slave unit.

The Slave units are automatically addressed and they do not need to be addressed manually.

To set the address manually:

- power off the Slave unit and connect the HMI to the unit
- enter the address and press "UNLOCK" to confirm
- power off the Slave unit and remove the HMI from the unit

13 CASCADE OPERATION

Connections

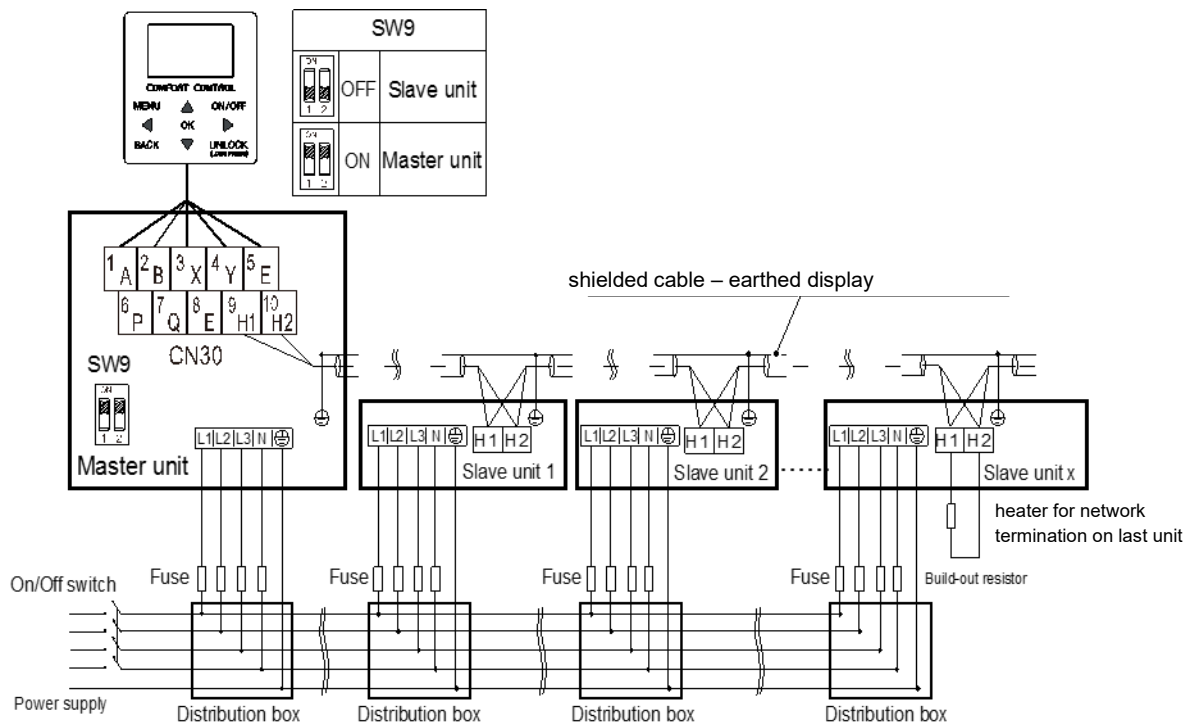

The Slave units are automatically addressed and they do not need to be addressed manually.

For the automatic addressing function to work properly, the units must be connected to the same power supply, shielded and then turned on together.

Notes:

- on the Master unit dip-switch SW9 must be set to “ON”
- only the Master unit can be connected to the HMI and during operations the Slave units must not be connected to the HMI

In a cascade system only the Master unit can:

- control the main sensors (Tbtu, TbtI, T5, Tw2, Tsolar, Ta)
- control the input signals (such as M1 / M2, room thermostat, adapter board, smart grid, solar input, etc.)
- monitor external elements (SV1, SV2, SV3, PUMPO, PUMPC, PUMPD, PUMPS, AHS, TBH, etc.)

Note:

The Slave unit can only control its T1 probe (leaving water temperature) and IBH probe (if its dip-switch is set to ON)

Communication standard : the RS-485

Communication protocol: ModbusRTU : 9600 , 8, N, 1

Baud rate: 9600 bps

Data bits : 8 Data bits

Check digit : None Parity

Stop bit: 1 stop bit

Slave address

PC and wired remote supports only one connection, wire is made from the unit.

The address of the remote control and the address of the hydraulic module (the hydraulic module selects the address by dialing code) should be the same .

Wiring methods

Connecting PCB of H1 , H2 of , E .

Wherein H2 is " + ", H1 is " - ", E is " the GND ."

Support the function code and abnormal code

03 and 16 function codes must be supported .

01	Query output status : Read Coils
03	Read holding registers : Read Holding Registers
06	Write a single register : Write Single Register
16	Write multiple registers : Write Multiple Registers
23	Read and write multiple registers: Read/Write multiple registers

Exception code description:

01	Illegal function code	Unsupported function codes
02	Illegal data address	The address sent during query or setting is not defined in the online controller
03	Illegal data value	Parameter set is an illegal value, over a reasonable range or wire set currently can not be set to a state parameters.

Check mode

CRC-16 . The calculation steps are as follows:

- 1) The initial value is FFFFH.
- 2) Calculate the XOR (logical exclusive OR) of the initial value (FFFFH) and the slave address .
- 3) Move the result of step 2 to the right by one bit. Until the remaining bits are " 1 ".
- 4) After the remaining bits are " 1 ", use the result of step 3 above and A001H to calculate XOR .
- 5) Repeat steps 3 and 4 until moving right 8 times.
- 6) Use the result of step 5 and the next data (function code, register address, data) of this information to calculate XOR . Repeat the calculation of 3~5 until the final data is obtained.
- 7) The final right shift result or the final XOR calculation value is the calculation result of CRC-16 .

14 MODBUS

Special instructions

The remote controller can be connected to the host computer or not.

As a slave, the line controller communicates normally with the host computer when it is connected to the host computer; when the host computer is not connected, the line controller does not send data or report a communication failure with the host computer.

Address table

Table 1 Unit set status query

Register address	Data content	Remarks	
0	Switch unit	BIT15	Reserved
		BIT14	Reserved
		BIT13	Reserved
		BIT12	Reserved
		BIT11	Reserved
		BIT10	Reserved
		BIT9	Reserved
		BIT8	Reserved
		BIT7	Reserved
		BIT6	Reserved
		BIT5	Reserved
		BIT4	Reserved
		BIT3	0: power off floor heating; 1: power on floor heating (zone 2)
		BIT2	0 : DHW(T5S) power off; 1 : DHW(T5S) power on
BIT1	0: power off floor heating; 1: power on floor heating (zone 1)		
BIT0	0: power off air conditioner; 1: power on air conditioner		
1	Setting mode	1: Auto; 2: Cool; 3: Heat; Others: Invalid	
	Set water temperature T1s	Bit8-Bit15 : set water temperature T1s corresponding to zone 2	
		BIT0-BIT7 : set water temperature T1s corresponding to zone 1	
3	Set temperature Ts	Room temperature setting, effective when there is Ta , 17°C ~30°C ; send value is equal to the actual value *2 ; for example, 17.5°C send value is 35	
4	T5s	Water tank temperature setting, 30°C ~60°C default 50	

5	Function setting	BIT15	Reserved
		BIT14	Reserved
		BIT13	1: curve setting enable; 0: curve setting disable (Zone2)
		BIT12	1: curve setting enable; 0: curve setting disable (Zone1)
		BIT11	DHW pump's running constant-temperature water recycling
		BIT10	ECO mode
		BIT9	Reserved
		BIT8	Holiday home (the status can only be read, not changed)
		BIT7	0: Silent mode level1; 1: Silent mode level2
		BIT6 :	Silent mode
		BIT5 :	Holiday away (the status can only be read, but cannot be changed)
		BIT4 :	Disinfect
		BIT3 :	Reserved
		BIT2 :	Reserved
		BIT1 :	Reserved
BIT0 :	Reserved		
6	Curve selection	Bit15-Bit8: Zone 2 curve 1-9	
		Bit0-Bit7: Zone 1 curve 1-9	
7	Forced water heating	0 : invalid 1 : Forced on 2 : Forced off	TBH is electric heating for making hot water tank. IBH is the electric heating behind the hydraulic module. TBH and IBH cannot be forced together
8	Forced TBH		
9	Forced IBH1		
10	SG running time	0-24hrs	

Note: Explanation of the T1s range of the floor heating set temperature:

Cooling mode T1S low temperature setting, range: 5-25°C

Cooling mode T1S high temperature setting, range: 18-25°C

Prepared heat mode T1S low-temperature setting, range: 25-55°C;

Prepared heat mode T1S temperature setting, range: 35-60°C.

Table 2 Unit operating status query

Register address	Data content	Remarks
100	Operating frequency	Compressor operating frequency in Hz
101	Operating mode	The actual operation mode of the whole unit, 2 : cooling , 3 : heating , 0 : OFF
102	Fan speed	Fan speed, unit r/min
103	PMV opening	External machines electronic expansion valve opening degree , the unit: P
104	Inlet water temperature	TW_in , unit: °C.
105	Outlet temperature	TW_out , unit: °C
106	T3 temperature	Condenser temperature , unit: °C
107	T4 temperature	Outdoor ambient temperature , unit: °C
108	Exhaust gas temperature	Compressor discharge temperature Tp of, unit: °C
109	Return air temperature	Compressor return air temperature, unit: °C
110	T1	Total outlet temperature, unit: °C
111	T1B	Total water output of the system (after auxiliary heat source), unit: °C
112	T2	Refrigerant liquid side temperature , unit: °C Send value = actual value
113	T2B	Temperature of refrigerant gas side , unit: °C Send value = actual value
114	Ta	Room temperature, unit: °C
115	T5	Water tank temperature, °C
116	Pressure value 1	High pressure value outside the machine, unit: K P A .
117	Pressure value 2	Outer pressure of low pressure, unit: K P A . (reserved)
118	Outdoor unit current	External unit running current, unit A ,
119	Outdoor unit voltage	A voltage value outside the unit , unit: V .
120	Tbt1	Tbt1 , unit: °C
121	--	--
122	Compressor running time	Compressor running time, unit: hour,
123	model	When the 200 register is 0702 , the model is reserved, and when it is 071x , the value represents the model capacity 4-30 represents 4-30Kw
124	Current fault	Midea standard fault coding method , specific fault code, refer to the code table
125	Fault 1	Midea standard fault coding For specific fault codes, refer to the code table.
126	Fault 2	
127	Fault 3	

128	Status bit 1	BIT15	Reserved
		BIT14	Reserved
		BIT13	Reserved
		BIT12	Reserved
		BIT11	EVU 1: Free electricity 0: judge based on SG signal
		BIT10	SG 1: normal electricity 0: high price electricity (judgment when EVU is 0)
		BIT9	Water tank anti-freezing reserved
		BIT8	Solar signal input
		BIT7	Room thermostat cooling
		BIT6 :	Room thermostat heating
		BIT5 :	External unit test mode flag reserved
		BIT4 :	Remote ONOFF(1:d8)
		BIT3 :	Oil return
		BIT2 :	Anti-freeze
		BIT1 :	Defrost
BIT0 :	Forced water pump reservation		
129	Load output	BIT15	DEFROST
		BIT14	External heat source
		BIT13	RUN
		BIT12	ALARM
		BIT11	Solar water pump
		BIT10	HEAT4
		BIT9	SV3
		BIT8	Mixed water pump P_c
		BIT7	Backwater pump P_d
		BIT6 :	External water pump P_o
		BIT5 :	SV2
		BIT4 :	SV1
		BIT3 :	Water pump PUMP_ I
		BIT2 :	Electric heating TBH
		BIT1 :	Electric heating IBH2
BIT0 :	Electric heating IBH1		
130	Unit version number	1~99 indicates the serial number of the whole machine, which refers to the version number of the hydraulic module	
131	Remote controller version number	1~99 indicates the serial number of the remote controller	
132	Unit target frequency		
133	DC bus current	Unit: Ampere	
134	DC bus voltage	Return value = actual value /10 (unit: volts)	
135	TF module temperature	Unit (°C) ---- External feedback	
136	Hydraulic module curve T1S calculation value 1	The actual value --- Zone 1 corresponding to the settlement result	
137	Hydraulic module curve T1S calculation value 2	The actual value --- Zone 2 corresponding to the calculation result	

14 MODBUS

138	Water flow	Actual value *100 unit: M3/H
139	External unit frequency limiting scheme	Solution value ----- external unit feedback 174
140	Hydraulic module capacity value	Actual value *100 unit: Kw
141	Solar sensor temperature	
142	Unit online number information	BIT1-BIT15 respectively represent the online status of slaves 1-15 BIT0 reservation
143	High battery value	
144	Low battery value	
145	High calorific value	
146	Low calorific value	

Table 3 Installation parameter query

200-208 are read-only registers; cannot be set, 209-

Register address	Data content	Remarks
200	Appliance type	The upper 8 digits are the types of household appliances: Central heating: 0x07 The middle three are product algebra First generation: 0 Second generation: 1 The lower 4 bits are subtypes R32 refrigerant medium frequency water pump model: 0x02
201	T1S cooling set temperature	The lower 8 bits are area 1 and the upper 8 bits are area 2
202	T1S cooling set temperature	The lower 8 bits are area 1 and the upper 8 bits are area 2
203	T1S heating set tempera-	The lower 8 bits are area 1 and the upper 8 bits are area 2
204	T1S heating set lower tem-	The lower 8 bits are area 1 and the upper 8 bits are area 2
205	TS set upper temperature	Actual value *2
206	TS set temperature lower	Actual value *2
207	Upper limit of set tempera-	
208	Lower limit of set tempera-	
209	PUMP RUNNING TIME	DHW PUMP backwater running time, the default is 5 minutes, the adjustment range is 5 ~ 120min , the adjustment interval is 1min

210	Parameter setting 1	BIT15	Enable hot water
		BIT14	Support water tank electric heating TBH (read only)
		BIT13	Support sterilization function
		BIT12	Whether to support DHW PUMP, 1 : support; 0 : not support
		BIT11	Reserved
		BIT10	DHW pump supports Pipe Disinfect
		BIT9	Cooling enable
		BIT8	T1S cooling high / low temperature setting (read only) Zone1
		BIT7	Heating enable
		BIT6 :	T1S heating high / low temperature setting (read only) Zone 1
		BIT5 :	Support T1 sensor
		BIT4 :	Support room temperature sensor Ta
		BIT3 :	Support room thermostat (Room thermostat)
		BIT2 :	Room thermostat MODESETTING
		BIT1 :	Dual Room Thermostat , 0 : not supported; 1 : supported
BIT0 :	0: room cooling/heating first, 1: water heating first		
211	Parameter setting 2	BIT15	Support reserve heat source (IBH) reservation
		BIT14	IBH supports heating function reservation
		BIT13	IBH supports hot water function reservation
		BIT12	Support AHS reservation
		BIT11	AHS supports heating function reservation
		BIT10	AHS supports hot water function reservation
		BIT9	Support solar module reservation
		BIT8	Input port definition: 0 : Remote switch 1 : DHW Heater
		BIT7	Smart Grid: 0 : None 1 : Yes
		BIT6 :	Tw2 sensor enable: 0 : None 1 : Yes
		BIT5 :	T1S cooling high / low temperature setting area 2
		BIT4 :	T1S heating high / low temperature setting area 2
		BIT3 :	Dual zone setting is effective
		BIT2 :	Reserved
		BIT1 :	Reserved
BIT0 :	Reserved		
212	dT5_On	Default: 10°C, range: 1 ~ 30°C, adjustment interval 1°C	
213	dT1S5	Default: 10, range: 5- 40°C, adjustment interval 1°C	
214	T_Interval_DHW	Default: 5min , range: . 5 ~ 5 min , adjustment interval 1min	
215	T4DHWmax	Default: 43°C, range 35-43°C, adjustment interval 1°C	

14 MODBUS

216	T4DHWmin	Default: - 25°C, the range of - 25 -5°C, adjusted spacing 1°C
217	t_TBH_delay	Default: 30 min Range: 0~240min ; adjustment interval 5min
218	dT5S_TBH_off	Default: 5°C, range: 0 ~ 10°C, adjustment interval 1°C
219	T4_TBH_on	Default: 5°C, range: -5~20°C, adjustment interval 1°C
220	T5s_DI	Sterilization function water tank set temperature, setting range 60~70°C, default 65°C
221	t_DI_max	Maximum value of sterilization cycle, setting range: 90~ 300 min , default 210 min ,
222	t_DI_hightemp	Sterilization high temperature time, setting range: 5~ 60 min , default 15min
223	t_interval_C	Cooling mode compressor start time interval; range: 5~ 5 min , default value is 5min
224	dT1SC	Default: 5°C, range: 2-10°C, adjustment interval 1°C
225	dTSC	Default: 2°C, range: 1-10°C, adjustment interval 1°C
226	T4cmax	Default: 52°C, range: 35- 52°C; adjustment interval 1°C
227	T4cmin	Default: -5°C, range: -5-25°C; adjustment interval 1°C
228	t_interval_H	System heating mode compressor start interval; range: . 5 ~ . 5 min , the default value . 5 min
229	dT1SH	Default: 5°C, range: 2-10°C, adjustment interval 1°C
230	dTSH	Default: 2°C, range: 1-10°C, adjustment interval 1°C
231	T4hmax	Default: 25°C, range: 20-35°C, adjustment interval 1°C
232	T4hmin	Default: - 25°C, range: -25 - 15°C, adjusted spacing . 1°C
233	T4_IBH_on	Ambient temperature of IBH for electric auxiliary heating of hydraulic module , setting range: -15~10°C, default value: -5°C
234	dT1_IBH_on	Hydraulic module electric auxiliary heating IBH opening temperature hysteresis, setting range: 2~10°C, default value 5°C
235	t_IBH_delay	Hydraulic module electric auxiliary heating IBH delay opening time, setting range: 15~120min , default value 30min
236	t_IBH12_delay	After the hydraulic IBH1 is turned on, the IBH2 is turned on delay time, the setting range: 5~30min , the default value is 5min, reserved to query the register and report the address error
237	T4_AHS_on	The external heat source AHS turns on the ambient temperature, the setting range is -15~10°C, the default value is -5°C
238	dT1_AHS_on	External heat source AHS opening temperature hysteresis, setting range: 2~10°C, default value 5°C
239	dT1_AHS_off	External heat source AHS shutdown temperature hysteresis, setting range: -5~0°C, the default value is 0°C reserved to query the address error reported by this register
240	t_AHS_delay	External heat source AHS lag opening time, setting range 5~120min , default value 30min.
241	t_DHWHP_max	Hot water system heat pump operation the maximum time setting range: 10 ~ 600 min ; Default: 90 min ; setting value minutes
242	t_DHWHP_restrict	The heat pump limits the time for running hot water, the setting range: 10~600 min ; the default value: 3 0min ; the setting value is minutes
243	T4autocmin	The default value is: 25°C, the range is: 20~29°C, the adjustment interval is 1°C
244	T4autohmax	The default value is: 17°C, the range is: 10~17°C, the adjustment interval is 1°C
245	T1S_H. A_H	During vacation, the setting value of T1 in heating mode , range: 20~25°C, default 25°C
246	T5S_H. A_DHW	During vacation, T1 setting value in hot water mode , range: 20~25°C, default 25°C
247	Startup percentage	Range 10-100 , default 10. Adjustment interval 10
248	Adjustment time	Range 1-60 Default 5
249	--	--
250	IBH1 power	Range 0-200 , default 0 , unit 100W
251	IBH2 power	Range 0-200 , default 0 , unit 100W

252	TBH power	Range 0-200 , default 0 , unit 100W
253	Comfort parameters	Reserved, query the register to report an address error
254	Comfort parameters	Reserved, query the register to report an address error
255	t_DRYUP	Heating days, setting range: 4~15days , default 8 days
256	t_HIGHPEAK	Drying days, setting range: 3~7days , default 5 days
257	t_DRYD	Cooling days, setting range: 4~15days , default 5 days
258	T_DRYPEAK	Maximum drying temperature, setting range: 30-55°C, default 45°C
259	t_firstFH	The first running time of floor heating , the default value is 72hrs , the setting range: 48-96hrs
260	T1S (first floor heating)	The first floor heating T1S , the setting range: 25 ~ 35°C, the default: 25°C;
261	T1SetC1	9 parameters of refrigeration temperature curve , setting range 5-25°C, default 10°C
262	T1SetC2	9 parameters of refrigeration temperature curve , setting range 5-25°C, default 16°C
263	T4C1	9 parameters of refrigeration temperature curve , setting range (-5)-46°C, default 35°C
264	T4C2	9 parameters of refrigeration temperature curve , setting range (-5)-46°C, default 25°C
265	T1SetH1	9 parameters of heating temperature curve , setting range 25-60°C, default 35°C
266	T1SetH2	9 parameters of heating temperature curve , setting range 25-60°C, default 28°C
267	T4H1	9 parameters of heating temperature curve , setting range (-25)-35°C, default -5°C
268	T4H2	9 parameters of heating temperature curve , setting range (-25)-35°C, default 7°C
269		Current frequency limit scheme , 0 : no setting; 1~8 : scheme 1~8 , default 0
270	HB: t_T4_FRESH_C	Range 0.5-6hour , adjustment interval 0.5 , send value = actual value *2
	LB: t_T4_FRESH_H	Range 0.5-6hour , adjustment interval 0.5 , send value = actual value *2
271	T_PUMPI_DELAY	Range 2-20 , adjustment interval 0.5 , send value = actual value *2
272	EMISSION TYPE	B it12-15 : region 2 cooling type terminal
		B it8-11 : zone 1 cooling type terminal
		B it4-7 : region 2 heating type terminal
		B it0-3 : zone 1 heating type terminal

14 MODBUS

Table 4 slave parameter query

Register address	Data content	Remarks
1000	Operating mode	The actual operation mode of the whole unit, 2 : cooling, 3 : heating, 0 : shutdown
1001	Operating frequency	Compressor operating frequency in Hz . Send value = actual value
1002	Inlet water temperature	TW_in , unit: °C. Send value = actual value
1003	Outlet temperature	TW_out , unit: °C. Send value = actual value
1004	Solar sensor temperature	Tsolar , unit: °C. Send value = actual value reserved
1005	Slave fault code	According to the US standard fault code
1006	P6 breakdown breakdown	ignore
1007	Indoor unit status 1	Bit3~7 reserved
		Bit2 oil return
		Bit1 antifreeze
		Bit0 defrost
1008	Indoor unit status 2	Whether Bit7 has TBH , 1 : yes, 0 : no reservation
		Whether Bit6 has AHS , 1 : yes, 0 : no reservation
		BIT5 the AHS operational mode, . 1 : the DHW , 0 : Heating (Judgment when AHS is valid) Reserved
		Bit4 whether a T1 1- there 0- No
		Does Bit3 have IBH 1- have 0- no
		Bit2 hot water operation reserved
		Bit1 heating operation
		Bit0 cooling operation
1009	Indoor unit load	BIT7 HEAT4 crankcase heating tape
		Bit6 STOVE gas stove reserved
		Bit5: DEFROST
		Bit4 RUN
		BIT3 water pump PUMP_i
		BIT2 electric heating TBH reserved
		BIT1 electric heating IBH2
		BIT0 electric heating IBH1
1010	Indoor unit load Reserved	Bit7 reserved
		BIT6 solar water pump PUMP
		BIT5 SV3
		BIT4 Hybrid Pump Pump_C Area 2 Pump
		BIT3 backwater pump Pump_D
		BIT2 external pump Pump_O
		BIT1 SV2
		BIT0 SV1

1011	T1	Total outlet temperature, unit: °C. Send value = actual value invalid value 0x7F
1012	T1B	Total water output of the system (after auxiliary heat source), unit: °C. Send value = actual value invalid value 0x7F
1013	T2	Refrigerant liquid side temperature , unit: °C. Send value = actual value invalid value 0x7F
1014	T2B	Temperature of refrigerant gas side , unit: °C. Send value = actual value invalid value 0x7F
1015	T5	Water tank temperature invalid value 0x7F
1016	Ta	Room temperature, unit: °C. Send value = actual value invalid value 0x7F
1017	Tbt1	Tbt1 , unit: °C. Send value = actual value invalid value 0x7F
1018	--	--
1019	Water flow	Actual value *100 unit: M3/H
1020	model	10-18 : stands for 10-18KW (valid for the second generation unit)
1021	Unit target frequency	
1022	Unit version number	1~99 indicates the serial number of the whole machine, which refers to the version number of the hydraulic module
1023	High calorific value	
1024	Low calorific value	
1025	Hydraulic module capacity value	Actual value *100 unit: Kw
1026	Wind speed	Fan speed, unit r/min . Send value = actual speed
1027	PMV opening	External machines electronic expansion valve opening degree , the unit: P . Send value = actual value (only display multiples of 8)
1028	T3 temperature	Condenser temperature, unit: °C. Send value = actual value invalid value 0x7F
1029	T4 temperature	Outdoor ambient temperature, unit: °C. Send value = actual value invalid value 0x7F
1030	Exhaust gas temperature	Compressor discharge temperature Tp , unit: °C. Send value = actual value invalid value 0x7F
1031	Return air temperature	Compressor return air temperature, unit: °C. Send value = actual value invalid value 0x7F
1032	TF module temperature	Unit (°C) ---- Invalid value of external feedback 0x7F
1033	Pressure value 1	High-pressure value of external machine, unit: kPA . Send value = true value
1034	Pressure value 2	Low pressure value of external machine, unit: kPA . Sent value = true value (reserved)
1035	DC bus current	Unit: Ampere
1036	DC bus voltage	Return value = actual value (unit: volts)
1037	External current	External unit running current, unit A , send value = actual value
1038	External voltage	A voltage value outside the unit, unit: V . Send value = actual value
1039	External unit frequency limiting scheme	Solution value ----- external unit feedback 174
1040	High battery value	
1041	Low battery value	
1042	Outdoor unit software version	

The above table is the modbus mapping table information of slave 1

Unit from X (2-15) information from the mapping table unit 1 address + (X-1) * 200

15 - General technical data

Performance

SIZE			81	91	101	121	141
Power supply			400/50/3+N				
RADIANT PANELS							
Heating							
Heating capacity (EN 14511:2018)	1,9	kW	16,3	18,0	22,0	26,0	30,1
Total power input (EN 14511:2018)	1	kW	3,63	3,83	5,00	6,37	7,70
COP (EN 14511:2018)	2		4,49	4,70	4,40	4,08	3,91
ErP Space Heating Energy Class - AVERAGE Climate - W35	8,11		A++	A+++	A+++	A+++	A++
SCOP - AVERAGE Climate - W35	10		4,30	4,60	4,53	4,50	4,19
Cooling							
Cooling capacity (EN 14511:2018)	5,9	kW	15,5	18,5	23,0	27,0	31,0
Total power input (EN 14511:2018)	5	kW	3,63	3,90	5,00	6,28	7,75
EER (EN 14511:2013)	6		4,27	4,75	4,60	4,30	4,00
Water flow-rate	5	l/s	0,74	0,88	1,10	1,29	1,48
Useful pump discharge head	5	kPa	19,6	99,5	89,4	74,4	54,0
TERMINAL UNIT							
Heating							
Heating capacity (EN 14511:2018)	3	kW	16,2	18,0	22,0	26,0	30,0
Total power input (EN 14511:2018)	3	kW	4,70	5,14	6,47	8,39	10,3
COP (EN 14511:2018)	2		3,45	3,50	3,40	3,10	2,90
Cooling							
Cooling capacity (EN 14511:2018)	7	kW	13,8	17,0	21,0	26,0	29,5
Total power input (EN 14511:2018)	7	kW	5,19	5,57	7,12	9,63	11,6
EER (EN 14511:2018)	6		2,66	3,05	2,95	2,70	2,55
SEER	10		4,54	4,70	4,70	4,66	4,49
Water flow-rate	7	l/s	0,66	0,81	1,00	1,05	1,10
Useful pump discharge head	7	kPa	30,7	102	94,6	78,8	59,4
RADIATORS							
Heating							
Heating capacity (EN 14511:2018)	4	kW	16,1	18,0	22,0	26,0	30,0
Total power input (EN 14511:2018)	4	kW	5,83	6,55	8,30	10,61	13,0
COP (EN 14511:2018)	2		2,76	2,75	2,65	2,45	2,30
ErP Space Heating Energy Class - AVERAGE Climate - W55	8		A++	A++	A++	A+	A+
SCOP - AVERAGE Climate - W55	10		3,27	3,21	3,22	3,14	3,14
Water flow-rate	4	l/s	0,48	0,54	0,66	0,78	0,90
Useful pump discharge head	4	kPa	55,5	109	106	103	99,1

The Product is compliant with the Erp (Energy Related Products) European Directive. It includes the Commission delegated Regulation (EU) No 811/2013 (rate heat output ≤ 70 kW at specified reference conditions) and the Commission delegated Regulation (EU) No 813/2013 (rated heat output ≤ 400 kW at specified reference conditions).

Contains fluorinated greenhouse gases(GWP 675).

1. Entering/leaving water temperature user side 30/35 °C, Entering external exchanger air temperature 7 °C (R.H. = 85%).
2. COP (EN 14511:2018) Heating performance coefficient. Ratio between delivered heating capacity and power input in compliance with EN 14511:2018.
3. Entering/leaving water temperature user side 40/45 °C, Entering external exchanger air temperature 7 °C (R.H. = 85%).
4. Entering/leaving water temperature user side 47/55 °C, Entering external exchanger air temperature 7 °C (R.H. = 85%).
5. Entering/leaving water temperature user side 23/18 °C, Entering external exchanger air temperature 35 °C.
6. EER (EN 14511:2018) cooling performance coefficient. Ratio between delivered cooling capacity and power input in compliance with EN 14511:2018.
7. User side entering/leaving water temperature 12/7 °C, external exchanger entering air 35°C.
8. Seasonal Space Heating Energy Efficiency Class according to Commission delegated Regulation (EU) No 811/2013. W = Water outlet temperature (°C).
9. Data referred to unit operation with inverter frequency optimized for this application.
10. Data calculated according to the EN 14825:2016 Regulation.

Construction

SIZE		81	91	101	121	141
Compressor						
Type of compressors		Rotary Inverter DC				
Refrigerant		R32				
No. of compressors	Nr	1	1	1	1	1
Oil charge	l	1,1	1,5	1,5	1,5	1,1
Refrigerant Charge	kg	2,8	5	5	5	5
User side exchanger						
Type of internal exchanger	1	PHE				
Water content	l	1,01	3,5	3,5	3,5	3,5
External Section Fans						
Type of fans		Brushless DC motor				
No. of fans	Nr	2	2	2	2	2
Standard airflow	m ³ /h	1710	2958	2958	3108	3108
Installed total power	kW	0,226	0,442	0,442	0,500	0,500
Water circuit						
Maximum water side pressure	kPa	300	300	300	300	300
Safety valve calibration	kPa	300	300	300	300	300
Minimum circuit water volume	l	40	40	40	40	40
Total internal water volume	l	3,2	3,5	3,5	3,5	3,5
Expansion tank volume	l	5	8	8	8	5
Expansion tank maximum working pressure	bar	8	3	3	3	3
Back-up electric heater capacity	kW	4,5	-	-	-	-

1. PHE = plate exchanger

General technical data

Sound levels - Standard Mode

SIZE	Sound power level								Sound pressure level	Sound power level
	Octave band (Hz)									
81	68	61	59	55	53	48	43	39	56	71
91	78	77	65	63	60	53	48	45	57	70
101	67	66	66	65	62	56	53	48	59	72
121	71	70	68	67	65	58	54	51	61	74
141	80	79	71	70	67	61	56	52	63	77

Sound levels refer to units with full load under nominal test conditions.
The sound pressure level refers to a distance of 1 meter from the outer surface of the unit operating in open field.
Noise levels are determined using the tensiometric method (UNI EN ISO 9614-2).

Sound levels - Silenced Mode

SIZE	Sound pressure level	Sound power level
	dB(A)	dB(A)
81	52	68
91	53	68
101	54	69
121	56	71
141	58	73

Sound levels refer to units with maximum test conditions.
For maximum capacity supplied in silent mode, a correction factor of 0,8 shall be used.
The sound pressure level refers to a distance of 1 meter from the outer surface of the unit operating in open field.
Noise levels are determined using the tensiometric method (UNI EN ISO 9614-2)

Data referred to the following conditions in heating:
- internal exchanger water = 30/35°C
- ambient temperature 7/6 °C
Data referred to the following conditions in cooling:
- internal exchanger water = 12/7°C
- ambient temperature 35°C

Sound levels - Super Silenced Mode

SIZE	Sound pressure level	Sound power level
	dB(A)	dB(A)
81	51	66
91	50	65
101	51	66
121	53	68
141	54	69

Sound levels refer to units with maximum test conditions.
For maximum capacity supplied in super silent mode, a correction factor of 0,6 shall be used.
The sound pressure level refers to a distance of 1 meter from the outer surface of the unit operating in open field.
Noise levels are determined using the tensiometric method (UNI EN ISO 9614-2).

Data referred to the following conditions in heating:
- internal exchanger water = 30/35°C
- ambient temperature 7/6 °C
Data referred to the following conditions in cooling:
- internal exchanger water = 12/7°C
- ambient temperature 35°C

Operating range

Cooling

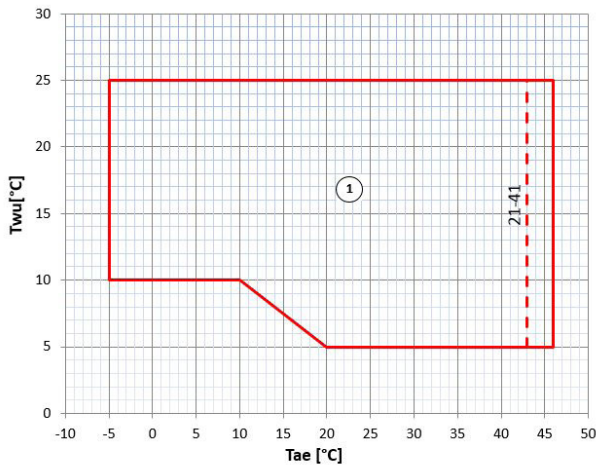

T_{wu} [°C] = Leaving exchanger water temperature
 T_{ae} [°C] = External exchanger inlet air temperature

1. Normal operating range

Heating

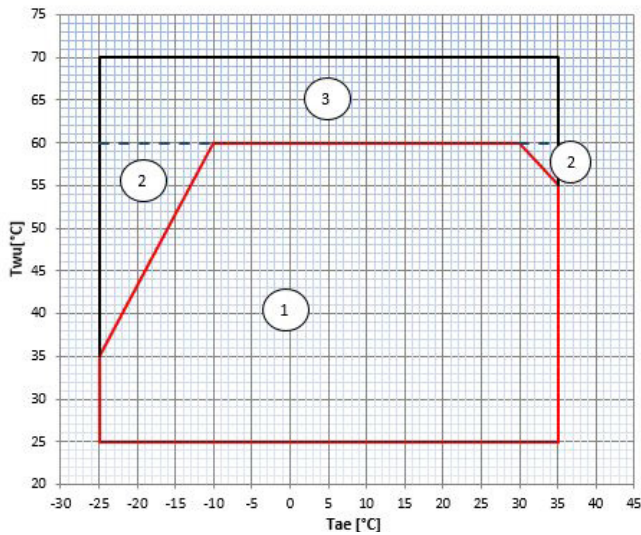

T_{wu} [°C] = Leaving exchanger water temperature
 T_{ae} [°C] = External exchanger inlet air temperature

1. Normal operating range
2. Operating range with only back-up heater
3. Operating range with the Hybrid version of the condensing boiler

⚠ The operating range with only the back-up heater depends on the specific size and is for reference only

DWH

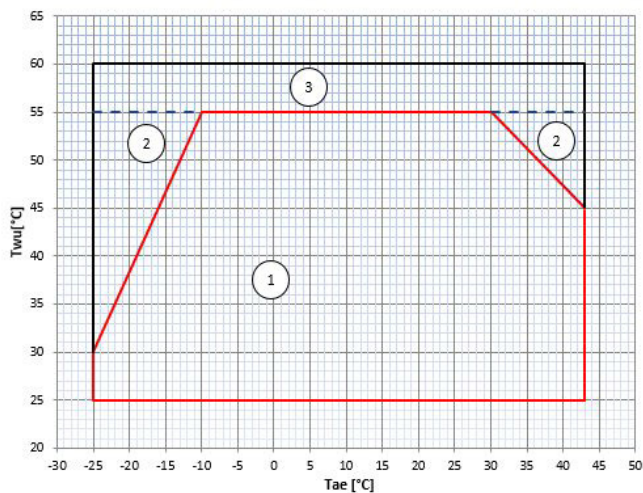

T_{wu} [°C] = Leaving exchanger water temperature
 T_{ae} [°C] = External exchanger inlet air temperature

1. Normal operating range
2. Operating range with only back-up heater
3. Operating range with the Hybrid version of the condensing boiler

General technical data

Admissible water flow rates

SIZE			81	91	101	121	141
Minimum flow-rate	Qmin	[l/s]	0,48	0,54	0,66	0,78	0,90
Maximum flow-rate	Qmin	[l/s]	0,92	1,03	1,26	1,49	1,72

Fouling Correction Factors

	Internal exchanger	
m ² C/W	F1	FK1
0,44x10 (-4)	1	1
0,88x10 (-4)	0,96	0,99
1,76x10 (-4)	0,93	0,98

The cooling performance values provided in the tables are based on the external exchanger having clean plates (fouling factor 1). For different fouling factor values, multiply the performance by the coefficients shown in the table.

F1 = Cooling capacity correction factors

FK1 = Compressor power input correction factor

Size 91-141 Three Phase

DABPB0001_0
DATA/DATE 14/05/2020

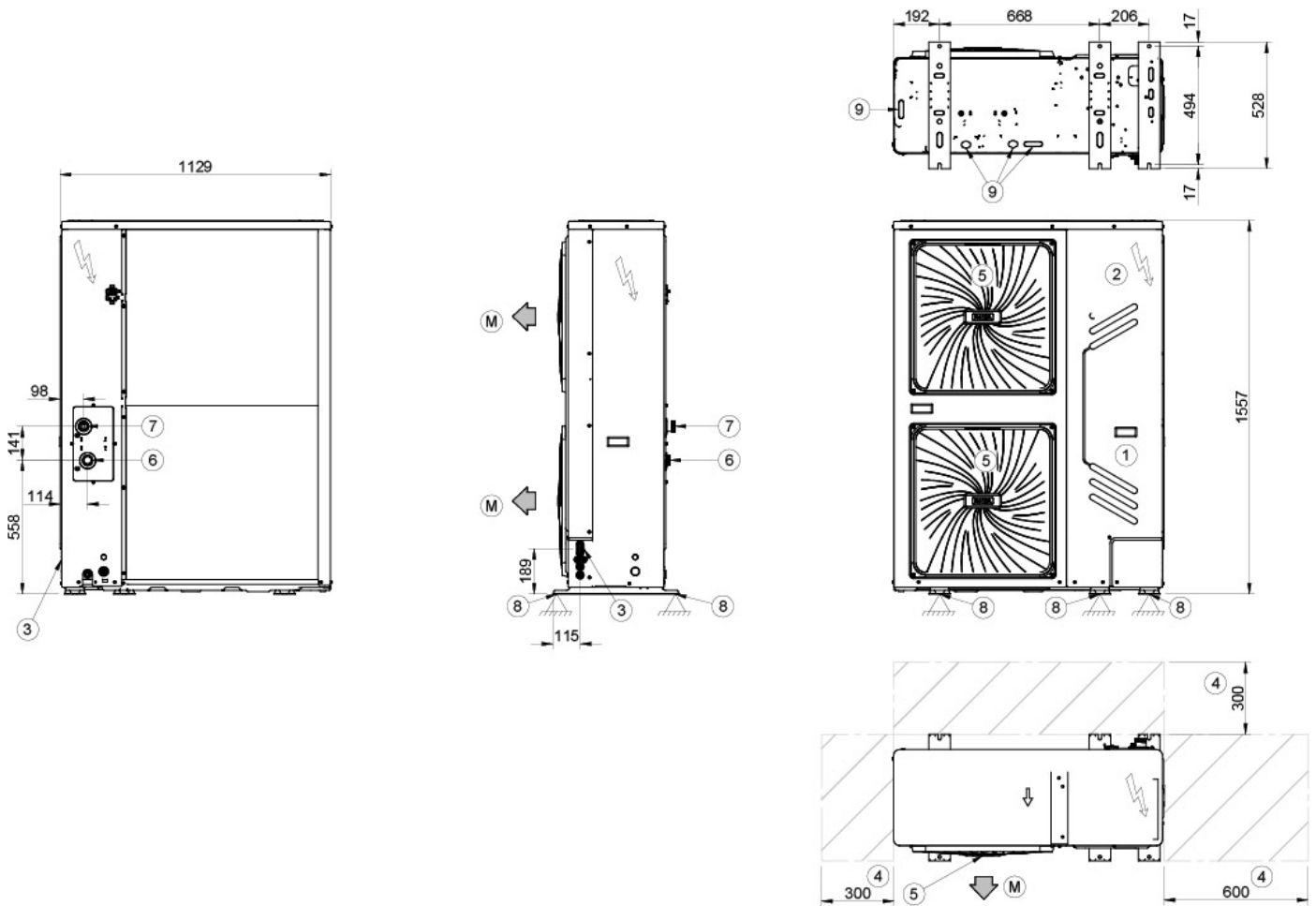

1. Compressor compartment
 2. Electrical panel
 3. Power input
 4. Functional spaces
 5. Electric fan (supply - return)
 6. Internal exchanger water inlet (OD = 1" 1/4 GAS M)
 7. Internal exchanger water outlet (OD = 1" 1/4 GAS M)
 8. Support point
 9. Drain hole
- (M) Air Supply

SIZE		91	101	121	141
Length	mm	1129	1129	1129	1129
Depth	mm	440	440	440	440
Height	mm	1558	1558	1558	1558
Operating weight	kg	177	177	177	177
Shipping weight	kg	206	206	206	206

The presence of optional accessories may result in a substantial variation of the weights shown in the table.

FOR OVER 30 YEARS, WE HAVE BEEN
OFFERING SOLUTIONS TO ENSURE
SUSTAINABLE COMFORT AND THE
WELL-BEING OF PEOPLE AND THE
ENVIRONMENT

www.clivet.com

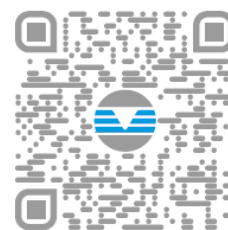

sales and assistance



CLIVET SPA

Via Camp Lonc 25, Z.I. Villapaiera

32032 Feltre (BL) - Italy

Tel. +39 0439 3131 - Fax +39 0439 313300

info@clivet.it

A Group Company of

