



HEAT TECHNOLOGY MANUFACTURER



EN

ATTACK SLX Instructions for use

CONTENT

1	INTRODUCTION	4
1.1	GENERAL DESCRIPTION	4
1.2	DESCRIPTION OF MARKINGS OF THE aTTACK SLX BOILERS	5
1.3	SAFETY	5
1.4	IMPORTANT INFORMATION	5
1.5	TECHNICAL DESCRIPTION	6
1.6	FUEL	7
1.6.1	WOOD	7
1.6.2	ALTERNATIVE FUELS	8
2	TECHNICAL PARAMETERS OF ATTACK SLX BOILERS	9
3	DIMENSIONS AND MAIN PARTS OF THE ATTACK® SLX BOILERS	10
4	PURPOSE OF USE	11
5	ASSEMBLY AND INSTALLATION OF THE BOILER	12
5.1	MANIPULATION WITH BOILER	12
5.2	GENERAL CONDITIONS OF INSTALLATION	12
5.3	BOILER PLACING	12
5.4	CONNECTION OF THE BOILER TO THE HEATING SYSTEM	13
5.4.1	USE OF ANTIFREEZE MIXTURE	14
5.4.2	PROTECTION AGAINST CORROSION	14
5.4.3	OUTFALL OF THE FLUE OUT OF THE BOILER	14
5.4.4	CONNECTION OF THE BOILER TO THE CHIMNEY	15
5.4.5	CONNECTION TO THE ELECTRICITY MAINS	16
5.4.6	OPTION AND THE WAY OF CONNECTION OF THE CONTROL AND SAFETY ELEMENTS	16
5.4.7	PROTECTION OF THE BOILER AGAINST OVERHEATING	17
5.4.8	CONNECTION TO THE ACCUMULATION TANKS	18
5.4.9	SCHEMES OF BOILER CONNECTION TO THE ACCUMULATION TANKS	19
5.4.10	STANDARDLY DELIVERED ACCUMULATION TANKS ATTACK*	22
5.5	BINDING NORMS FOR DESIGNING AND ASSEMBLY OF THE BOILERS	23
6	BOILER OPERATION	23
6.1	OPERATING PRESCRIPTIONS	23
6.2	HEATING UP, OPERATION AND FUEL REFILLING	24
6.2.1	PROTECTIVE TOOLS FOR WORK WITH THE BOILER	29
6.3	CONTROL OF THE ATTACK SLX PROFI BOILER	29
6.3.1	ADVANTAGES OF REGULATOR	29
6.3.2	BASIC DESCRIPTION OF THE REGULATOR	30
6.3.3	CONNECTION OF THE PROFI PID REGULATOR BY HYDRAULIC SCHEMES	31
6.3.4	REGULATOR CONTROL AND OPERATING MODES	36
6.3.5	SETTING THE USER PARAMETERS	36
6.3.6	SETTING THE SERVICE PARAMETERS	38
6.3.7	DESCRIPTION OF PARAMETERS	39
6.3.8	ERROR MESSAGES	42

6.3.9	DISASSEMBLY OF THE REGULATOR	43
6.3.10	TECHNICAL SPECIFICATION OF THE REGULATOR.....	43
6.3.11	SETTING THE AIR FLAPS AND FLUE GAS TEMPERATURE	43
6.4	ATTACK SLX LAMBDA TOUCH BOILER CONTROL	45
6.4.1	BASIC CONTROL ELEMENTS	45
6.4.2	WORKING METHOD OF LAMBDA TOUCH CONTROLLER	46
6.4.3	TESTMODE.....	47
6.4.4	STARTING UP THE REGULATOR.....	51
6.5	DISPLAYING THE INFORMATION	57
6.5.1	SETTING THE PARAMETERS.....	58
6.5.2	GENERAL SETTINGS	60
6.5.3	CONNECTION TO THE INTERNET.....	62
6.5.4	SOFTWARE UPDATE	65
6.5.5	FACTORY SETTINGS AND RESET	66
7	RISK ANALYSIS	67
8	BOILER MAINTENANCE	69
8.1	BOILER CLEANING.....	70
8.2	INSTALLATION AND REPLACING OF FIREPROOF PARTS.....	71
9	TRANSPORT, MANIPULATION AND STORING.....	72
9.1	INSTRUCTIONS TO PRODUCT DISPOSAL AFTER TERMINATION OF ITS LIFE – TIME	72
9.2	WRAPPING DISPOSAL.....	72
9.3	ACCESSORIES	73
10	AUTOMATIC BOILER CONTROL	73
11	POSSIBLE FAILURES AND THE WAY OF ITS REMOVAL.....	76
12	CHARACTERISTIC OF TEMPERATURE SENSORS	77
13	SERVICE PARAMETERS SETTINGS.....	78
14	ELECTRICAL SCHEMES.....	85
14.1	ATTACK SLX PROFI	85
14.2	ATTACK SLX LAMBDA TOUCH.....	86
15	RECOMMENDED SCHEMES OF CONNECTION.....	87
15.1	CONNECTION OF THE BOILER WITH 1 HEATING CIRCUIT WITH DHW.....	87
15.2	CONNECTION OF THE BOILER WITH 1 HEATING CIRCUIT WITHOUT DHW.....	88
15.3	CONNECTION OF THE BOILER WITH 2 HEATING CIRCUITS WITHOUT DHW.....	89
15.4	CONNECTION OF THE BOILER WITH 2 HEATING CIRCUITS WITH DHW	90
	THE ORIGINAL ES DECLARATION OF CONFORMITY	91

1 INTRODUCTION

Dear customer,

thank you for your trust and purchase of our product – wood gasifying boiler ATTACK SLX. We wish it serves you reliably for a long time. The reliable and correct function of device is related to its operation and therefore it is necessary to read this user manual. The manual is written with respect to the correct function of the boiler.

The correct function of the boiler particularly depends on the following:

- choice of the correct boiler output and type
- perfect commissioning
- correct operation
- regular professional maintenance
- reliable service

1.1 GENERAL DESCRIPTION

Name:	Wood gasifying boiler ATTACK SLX 20, 25, 30, 35, 40, 45, 50, 55 In version „PROFI“, „LAMBDA Touch“
Type:	ATTACK SLX 20, 25, 30, 35, 40, 45, 50, 55
Max. operation pressure:	250 kPa (2,5 bar)
Electr. power supply:	230 V/50 Hz/10 A
Elektr. input:	20, 25, 30, 35 SLX – 42 W 40, 45, 50, 55 SLX – 78 W
Fuel:	Dry wood with calorific value 15 up to 17 MJ/kg, moisture 12 up to 20 %, diameter 80 up to 150 mm
Nominal output:	20, 25, 30, 35, 40, 45, 50, 55 kW

Gasifying boiler ATTACK SLX is intended for economical and ecological heating of the family houses, cottages, small plants, workshops and similar objects.

Prescribed fuel for ATTACK SLX is dry wood logs or chopped pieces with length according to the type of the boiler.

Water temperature in cooling circuit has to be 8–12 °C. Water pressure is fixed: 0,25 MPa min. and 0,6 MPa max.

ATTACK SLX boilers work in non – condensation operation. Behind the chimney connection work in overpressure operation.

Level of the acoustic pressure A does not exceed 70 dB (A).

Immediate peak value of the acoustic pressure C does not exceed 63 Pa.

Producer ATTACK, s.r.o. reserves the right of technical changes of products without previous notification.

1.2 DESCRIPTION OF MARKINGS OF THE aTTACK SLX BOILERS

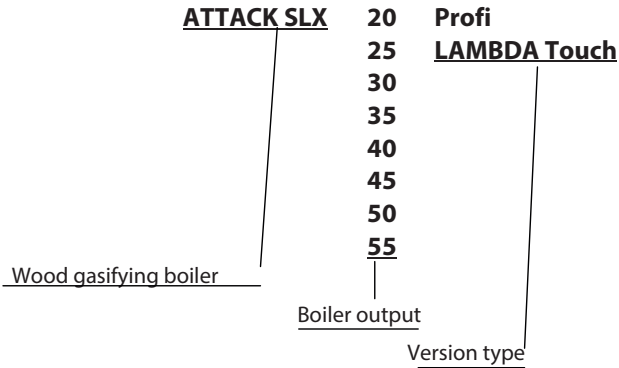

1.3 SAFETY

In this manual are used following warning symbols for illustration of the danger importance and important safety notifications:



CAUTION! Immediate danger situation and it could lead to the serious health or property damage if the right steps are not taken. Take the action according to the instructions!



WARNING: Dangerous situation might occur. It could lead to the serious health or property damage if the right steps are not taken. Work with extreme caution!



NOTICE: Dangerous situation might occur. It could lead to the serious health or property damage if the right steps are not taken.

1.4 IMPORTANT INFORMATION

- Boiler is delivered with documents and components in the feeding chamber, because of that, please ensure before first heat up, that the feeding chamber is empty.
- Assembly, checking heat up and training of the operation is performed by the assembly technician who is trained by the producer and s(he) also fill protocol about the boiler installation.
- During the gasification, tar and condensates (acids) are created in the fuel tray. That is why the mixing device has to be installed behind the boiler, to ensure the minimum temperature of the backflow water to the boiler 65 °C. Operation temperature of the water in the boiler has to be in range of 80–90 °C.
- Boiler must not be operated constantly in the output range lower than 50 %.
- Ecological operation of the boiler is by the nominal output.
- That is why we recommend to install the boiler with accumulation tanks and mixing device, what ensures 20–30 % fuel saving and longer lifetime of the boiler and chimney with more comfortable operation.

- We recommend to connect the boiler with accumulation tank with minimum volume of 70 l to 1 kW boiler output.
- Use only dry fuel with 12–20 % moisture (with higher fuel moisture is decreased boiler output and increases its consumption)
- Right choice of the boiler size, i.e. its heat output, is very important condition for economical operation and correct function of the boiler. Boiler has to be chosen according to its nominal output, which must meet the heat losses of the heated object.



WARNING: Boiler might be used only for intended purpose and only in the way described in this manual.



CAUTION: After the boiler disconnection from electricity mains during the operation, burning continues in the sustain mode. Do not open the boiler door until the temperature drops below 40 °C.

The boiler warranty is not valid, if:

- Is not operated with prescribed fuel
- In the system is not installed the mixing device ATTACK – OVENTROP, which ensures the backflow water temperature to the boiler at least 65 °C during the operation
- Functional thermostatic valve wont be installed at the aftercooling circuit of the boiler (e.g. WATTS STS20) and then connected to the source of the cooling water.
- Boiler is not installed according to the requirements stated in this manual, e.g. correct dimensions of the chimney etc.
- Is not sufficiently cleaned according to the instructions given in this manual

This appliance is not intended for use by persons (including children) with physical, sensual or mental disability or insufficient experience due to which they are not able to use the device in a safe way without being supervised or instructed about the boiler operation by the person responsible for their safety. Do not to allow children to play with this appliance.



If the power supply cable is damaged, it must be replaced with the correct type of the cable, which is available by producer or by a service technician!



Be careful during the work with this appliance! Lambda probe works by high temperatures (300 °C) and you might get burned during careless manipulation!

1.5 TECHNICAL DESCRIPTION

Boiler is constructed for wood combustion, based on the gasifying with use of exhaust fan, which makes forced flow in the boiler and sucks the flue gas out of the boiler. Boiler body is made as the weld from steel plates of 6 mm thickness. In the upper part of the boiler is feeding chamber with above – standard volume, equipped with dry sheath technology, which lowers the condensate creation and prolong lifetime of the boiler. In the bottom part of the feeding chamber is fireproof nozzle with longitudinal hole for crossing the wood gas to the combustion chamber. Secondary air is brought by the nozzle and after mixing with wood gas creates burning in the combustion chamber. Combustion chamber is also the ashtray, where are collected wastes after combustion (ash). In the rear part of the boiler body is tubular exchanger equipped with turbulators, which serves for cleaning the exchanger and increasing the boiler efficiency. Turbulators might be controlled manually or automatically (using engine) according to the boil-

er version PROFI or LAMBDA Touch. In the upper part of the boiler is situated boiler regulation, which controls the wood gasification process and offers all important information about the boiler operation. Flue gas suction by the feeding is solved by the exhaust canal in the upper part of the combustion chamber and leads directly to the chimney – go around the exchanger. Boiler is designed for long period of combustion (4 up to 8 hrs, depending on the output) and that is why it needs to be equipped with accumulation tank.

1.6 FUEL

1.6.1 WOOD

In the ATTACK SLX boiler is possible to use soft and hard chopped fuelwood with calorific value in range of 15 to 17 MJ/kg. Ideal are especially beech, oak, fir, spruce, pine, poplar tree, alder, willow, birch, ash tree, hornbeam, locust tree, always with moisture in range of 12 up to 20 %. Suitable diameter of logs is in range of 80 up to 150 mm. Maximal length of the logs must not exceed 680 mm for 20, 25, 30, 35 SLX boilers and 780 mm for 40, 45, 50, 55 SLX boilers to prevent wood jam in the feeding chamber.

Calorific value of particular types of wood:

Wood	Units		
	Kcal/kg	MJ/kg	kWh/kg
Spruce	3 900	16,25	4,5
Pine	3 800	15,80	4,4
Birch	3 750	15,50	4,3
Oak	3 600	15,10	4,2
Beech	3 450	14,40	4,0



WARNING: Unsuitable moisture or size of the wood might cause lowering or increasing the output, low or high temperature of the flue gas, excessive condensation, flame loss of the gasifying process or uncontrollable combustion.

Recommended wood storing and drying:

Hard wood: stored in dry environment for 2 years

Soft wood: stored in dry environment for 1 year

Wood must be secured against rain during storage (drying). You can help to the wood drying effectiveness by storing the wood with as large as possible spaces between each piece of wood to let the air flow between them. It is good to store the wood in the environment with air draught, what ensures faster drying. If possible, store the wood at least 1 day in the warm place (e.g. boiler room – wood will be preheated and it will lead to the combustion effectiveness) before feeding in the boiler.

1.6.2 ALTERNATIVE FUELS

It is possible to use also wood briquettes with hole, pressed from wood sawdusts without any additional connective materials. It is necessary to mix wood briquettes with wood in particular ratio (ratio depends on the size and shape of the briquettes), to prevent clogging of the nozzle for wood gasifying.



WARNING: Fuels, which are not allowed increase demands on cleaning and lead to the accumulation of aggressive sedimentation and condensation. In the end, it might lead to lowered functionality, boiler damage and invalid warranty. Use of unallowed fuels might lead to incorrect and uncontrollable combustion.

2 TECHNICAL PARAMETERS OF ATTACK SLX BOILERS

Parameter / Boiler type		SLX20	SLX25	SLX30	SLX35	SLX40	SLX45	SLX50	SLX55
Nominal output of the boiler	kW	20	25	30	35	40	45	50	55
Output range	kW	10 – 20	12,5 – 25	15 – 30	17,5 – 35	20–40	22,5–45	25–50	27,5–55
Area of the exchanger	m ²	2,95				3,32			
Volume of the feeding chamber	dm ³	200				230			
Dimensions of the feeding hole	mm	235 × 445							
Prescribed chimney draught	Pa	23							
Prescribed chimney draught	mbar	0,23							
Max. working overpressure of the water	kPa	250							
Pressure loss of the water (ΔT 10K)	kPa	1,9	2,1	2,4	2,7	3,9	4,5	5,2	6,1
Pressure loss of the water (ΔT 20K)	kPa	0,8	0,9	1,2	1,6	1,9	2,1	2,4	3,2
Weight of the boiler	kg	570				650			
Diameter of the flue gas outlet	mm	150							
Height of the boiler	mm	1 472							
Width of the boiler	mm	703							
Depth of the boiler	mm	1 337				1 506			
Depth of the feeding chamber	mm	690				790			
Diameter of the riser pipe "E"	"	G 6/4"				G 2"			
Diameter of the reverse "F"	"	G 6/4"				G 2"			
Protection class	IP	20							
Electrical input at the nominal output	W	42	42	42	42	78	78	78	78
Electrical input at the minimal output	W	31	31	31	31	52	52	52	52
Electrical input at the standby mode	W	< 15	< 15	< 15	< 15	< 15	< 15	< 15	< 15
Boiler efficiency	%	91,8	91,6	90,3		90,4		90,3	
Boiler class	—	5							
Temperature of the flue gas by the nominal output	°C	165	170	175	180	165	170	170	180
Temperature of the flue gas by the minimal output	°C	130	135	140	145	135	140	140	145
Mass flow of the flue gas by the nominal output	kg/s	0,018	0,02	0,021	0,023	0,027	0,029	0,031	0,033
Mass flow of the flue gas by the minimal output	kg/s	0,008	0,011	0,014	0,016	0,017	0,021	0,022	0,023
Max. noise level	dB	65							
Class and type of the fuel	—	A, Wood pieces with relative moisture of 12 % – max. 20 %, Ø 50–150 mm							
Average wood consumption	kg/h	5,2	6,5	7,8	9,1	10,4	11,7	13	14,3
Indicative consumption of the wood per season	—	1 kW = 1 m ³							
Max. length of logs	mm	650				750			
Time of burning by nominal output *	h	8	7,2	6,5	5,8	6	5,1	4,6	4
Volume of the water in the boiler	l	117				136			
Recommended volume of the accumulation tank	l	1500	2000	2200	2500	3 000	3 200	3 500	4 000
Voltage	V/Hz	~230/50							
Range of the setting the temperature of the heating water	°C	65 ÷ 85							
Capacity of the contacts of the boiler regulator (PROFI version)	—	2 A/~230 V							

*depending on the type of fuel and perfection of the feeding the chamber with wood

Producer ATTACK, s.r.o. reserves the right of technical changes of products without previous notification.

3 DIMENSIONS AND MAIN PARTS OF THE ATTACK® SLX BOILERS

Dimensions of the boilers with output of 20 – 35 SLX:

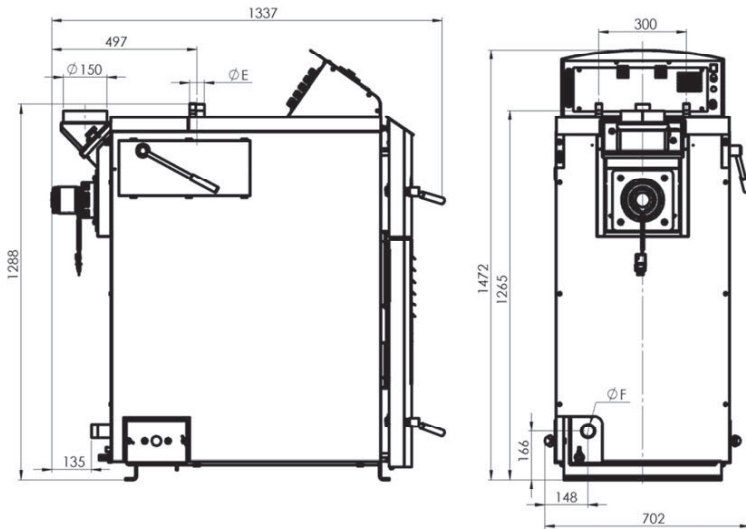

Dimensions of the boilers with output of 40 – 55 SLX:

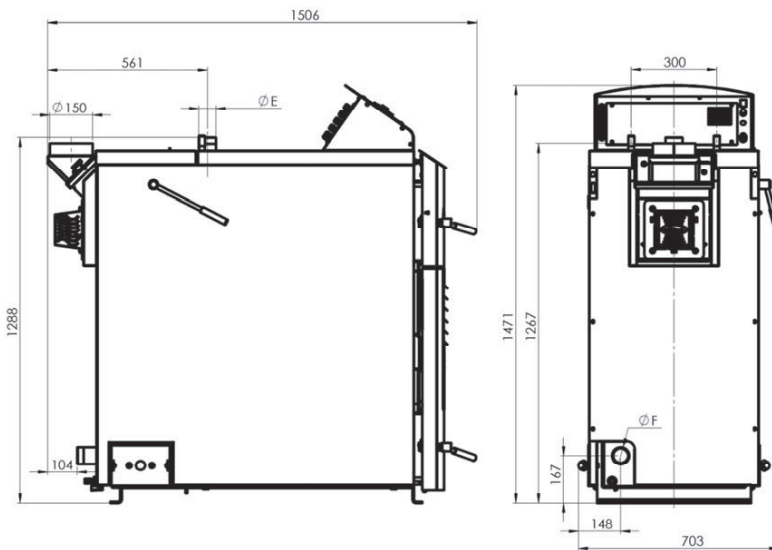

	SLX20	SLX25	SLX30	SLX35	SLX40	SLX45	SLX50	SLX55
Riser pipe – „E“	G 6/4"	G 6/4"	G 6/4"	G 6/4"	G2"	G2"	G2"	G2"
Reverse – „F“	G 6/4"	G 6/4"	G 6/4"	G 6/4"	G2"	G2"	G2"	G2"

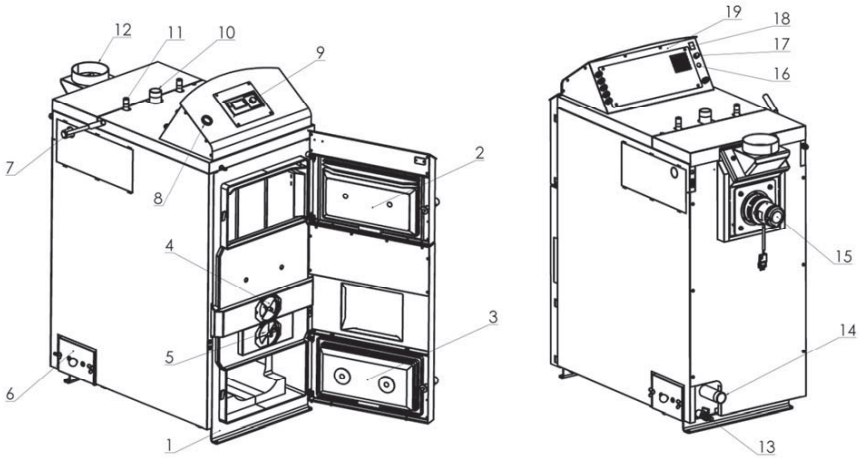
**CAPTION:**

- | | | | |
|-----------------------------------|----------------------------|--------------------------|--------------------------|
| 1. Body of the boiler | 6. Cleaning covering | 11. Aftercooling circuit | 16. Lambda fuse |
| 2. Door of the feeding chamber | 7. Lever of turbulators | 12. Rotary chimney | 17. Emergency thermostat |
| 3. Door of the combustion chamber | 8. Manometer | 13. Release valve | 18. Main switch Lambda |
| 4. Primary air | 9. Regulator of the boiler | 14. Reverse | 19. Control case |
| 5. Secondary air | 10. Riser pipe | 15. Fan | |

4 PURPOSE OF USE

Ecological warm water boiler Attack SLX is intended for heating family houses and other similar objects. Boiler is constructed for combusting wood pieces. It is possible to use any dry wood, especially wood logs for combustion. Boiler is not intended for combustion of the sawdusts and small wood wastes. It is possible to combust it only in small quantity (max. 10 %) together with wood pieces. Massive fuel feeder replaces and removes hardest operation during the wood preparation and its chopping to smaller pieces.



Placing boilers in dwelling premises (including corridors) is impermissible!

5 ASSEMBLY AND INSTALLATION OF THE BOILER

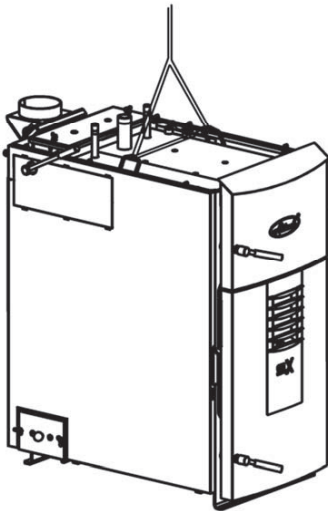

5.1 MANIPULATION WITH BOILER

Boiler is delivered on the pallet. Perform manipulation with boiler only at the pallet. Put down the boiler from the pallet immediately at the place of installation. It is possible to perform this by use of manipulation cart or by crane and handles, which are welded at the exchanger of the boiler.

Pic. 1 Manipulation with boiler with use of the welded handles

5.2 GENERAL CONDITIONS OF INSTALLATION

Only a person with valid authorization for installation and assembly of the heating technology devices can install the boiler. The installation requires an appropriate project that is in line with valid prescriptions. Technician must check the boiler before installing, if data given on the production label are in conformity with data in the project and the documentation attached to the boiler. The boiler connection must be in line with the valid prescriptions, norms, regulations and this instruction manual.



WARNING: Producer takes no responsibility for damages caused by wrong connection or operation!

5.3 BOILER PLACING

Boiler serves for installation and operation in the space with the basic environment (AA5/AB5) according to STN 33 2000 – 1: 2009 – 04.

Boiler room must meet the following requirements:

- Boiler is not suitable for use in the potentially explosive environment.
- The temperature in the boiler room must not drop below the freezing point.
- Boiler does not provide any lighting. Customer must ensure sufficient light source according to the local norms and regulations.
- It is necessary to consult the installation with the producer, if the boiler will be installed at height above sea level exceeding 1 800 m.
- Boiler room must have sufficient ventilation and inlet of the required burning air (minimally 10 cm²/kW of the boiler output). Hole for the ventilation should be designed to not let the outside weather influence its function. (rain, snow, wind)

During the installation of the boiler must be ensured a safe distance of its surface from the flammable materials depending on their flammability level:

- | | |
|---|--------|
| • Materials of flammability level B, C1 a C2 | 200 mm |
| • Materials of flammability level C3 | 400 mm |
| • Level of flammability was not proved according to STN 73 0853 | 400 mm |

Examples of building materials division according to the level of flammability:

- Level of flammability A not flammable (bricks, breeze blocks, ceramic tile, mortar, plaster)
- Level of flammability B partly flammable (heraclit, lignos, board made out of basaltic felt, novodur)
- Level of flammability C1 hard flammable (broadleaf wood (beech, oak), plywood, werzali, hardened paper)
- Level of flammability C2 intermediate flammable (coniferous wood (pine, spruce), chipboard, so-lodur)
- Level of flammability C3 easily flammable (wood – fibre, polyurethan, PVC, soft foam, polystyrene)

The sealing board or protection covering (on the protected object) must exceed the boiler edge at least for 300 mm. Also other items from flammable materials must be protected in this way, if they are placed near the boiler and it is not possible to keep the safe distance.

If the boiler stands on the flammable surface, it must be protected by an inflammable, heat insulating mat, which exceeds the ground plan on the side of the feeding door and ash tray door for at least 100 mm. All materials of the flammability level A might be used as an inflammable, heat insulating mat.

Boiler must be placed in a such way, ensuring sufficient space of at least 1 m from the front and 0,5 m from the left (right) and rear side. It is necessary to leave the space of at least 1 m above the boiler.

This space is necessary for basic operation, maintenance and eventual service of the boiler. It is not allowed to place the boiler in dwelling premises (including corridors).



WARNING: Items from flammable materials must not be laid on the boiler and in the distance shorter than the permitted (safe) one. The boiler must be put out of operation, if there is a danger of fire or explosion during the work (e.g. work with painting materials, glues, etc.).

5.4 CONNECTION OF THE BOILER TO THE HEATING SYSTEM

Boiler ATTACK® SLX has to be installed in the system, which meets the requirements of the heating water quality as follows:

Country	Number of standards	Country	Number of standards
Slovak republic	STN 07 7401:1991	Switzerland	SWKI 97 – 1
Austria	ONORM H5195 – 1	Italy	D.P.R. no. 412
Germany	VDI 2035		

For filling or refilling the water in the system might be used only water which is adapted for valves according to STN 07 7401: 1992. Water has to be clear, colourless, without any suspended substances, oils and chemical aggressive additives and cannot be acidic (pH has to be higher than 7,2). Water hardness cannot exceed 1 mmol/l and concentration of Ca²⁺ 0,3 mmol/l.



NOTICE: The warranty of the boiler is not valid in case of infringement of these conditions!

5.4.1 USE OF ANTIFREEZE MIXTURE

It is not recommended to use antifreeze mixture with not suitable quality for the boiler operation. It is related especially to lowering the heat penetration, big volume expandability, aging, rubber parts damage. If necessary, use the Alycol Termo (manufacturer Slovnaft Bratislava) antifreezing mixture – according to experiences of producer, there is no risk of lowering the safety of use and noticeable influencing of the boiler work. If this type of protection against freezing is not achievable in particular conditions, parameters are not fulfilled or there are some boiler failures caused by use of other antifreezing mixtures, there is no possibility of warranty.

5.4.2 PROTECTION AGAINST CORROSION

Boiler must be connected with device for controlling the temperature of the boiler reverse. Suitable solution is use of mixing device ATTACK – OVENTROP (Figure 2), which makes the temperature rise of the return connection to acceptable level. In this way is boiler protected against supercooling below 65 °C and creation of the water steams, acids and tars in the feeding chamber is lowered. Mixing device ATTACK – OVENTROP allows to set temperature of return – water in range of ca. 50 – 70 °C thanks to the thermostatic head.

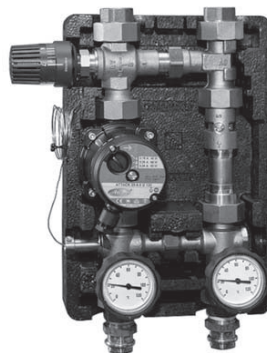

Fig. 2 *Device for protection of the reverse temperature
ATTACK OVENTROP*



NOTICE: If the device against corrosion is not installed in the system or this device does not work properly, there is a possibility of creation of aggressive condensate, which might lead to the boiler damage. **Protection against condensation must be in use during the boiler operation, otherwise is warranty provided by producer not valid!**

Use of the size of ATTACK OVENTROP devices depending on the boiler output:

ATTACK OVENTROP DN25: SLX 20–35 kW

ATTACK OVENTROP DN32: SLX 40–55 kW

5.4.3 OUTFALL OF THE FLUE OUT OF THE BOILER

Flue has to have outfall to the chimney hole. If it is not possible to connect the boiler to the chimney hole directly, then the appropriate extension should be as short as possible, of up to 1 m length, without any additional heating area and it must ascend to the chimney. It is good to insulate the flue, to achieve sufficient flue gas temperature and prevent the chimney condensation. Flues must be mechanically firm (it is recommended to attach the flue to the boiler and bolt them together) and tight against the flue leakage and cleanable inside. Flues must not lead through the somebody else's dwelling or commercial premises. The internal diameter of the flue must not taper in direction to the chimney. It is not eligible to use the elbow connectors. There must be an „T – shaped“ connection between flue and chimney to let the condensate flow down to the intended container and not in the boiler.

5.4.4 CONNECTION OF THE BOILER TO THE CHIMNEY

Connection of the appliance to the chimney hole must be always done with permission of the appropriate chimney sweep association. The chimney hole must always generate sufficient draught and take the flue gas out into the atmosphere under the all operating conditions. Correct dimensions of the chimney hole are important for correct boiler function, because burning, output and boiler life – time are influenced by the draught. The chimney draught directly depends on its diameter, height and roughness of the internal wall. It is not allowed to connect any other appliance to the chimney, where is the boiler connected. Diameter of the chimney must not be smaller than the outlet part of the boiler. Chimney draught must achieve prescribed values. It cannot be too high to not decrease the boiler output and interrupt the burning (flame). If there is too strong draught, install the throttle flap into the chimney hole between the boiler and the chimney.

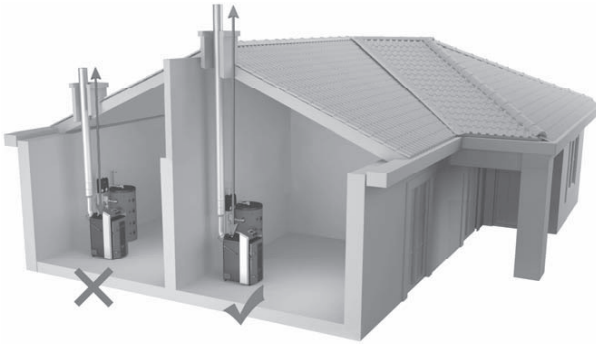

Less than 8m - low chimney =
INCORRECT!

For correct boiler operation
min. chimney height 8m

Pic. 3 Correct and incorrect parameters of the chimney for connection the SLX boiler

Prescribed values of the chimney diameter and height:

20 × 20 cm	min. height 7 m
Ø 20 cm	min. height 8 m
15 × 15 cm	min. height 11 m
Ø 16 cm	min. height 12 m

Exact dimensions of the chimney determines STN 73 42 10. Prescribed chimney draught is stated in Technical parameters. Chimney draught is measured by the devices intended for this operation, minimally 40 cm behind the outfall of the chimney. Draught is measured during the boiler operation at full output, by the same temperature of flue gas as the set one.

In case, that your chimney does not achieve prescribed parameters of the chimney, it is possible to install additional fan **ATTACK PV150** behind the boiler, which is able to make required parameters of the chimney.

It is necessary to keep in mind by choosing the type of the chimney or during the boiler operation, that **stainless insulated** chimney (most of the time placed externally at the sheathing of the building) has the best qualities of the chimney draught beginning after heat up, because it is quickly warmed in a whole length. Chimney with **stainless insertions** has worse qualities of the chimney draught beginning, because it is warmed slower than insulated chimney. Worst qualities

of the chimney draught beginning has chimney **without insertions** (e.g. brick or ceramic), because its accumulation to operation temperature takes much longer. So, if the heat up or boiler start up is problematic, consider reconstruction of the chimney and equipping the chimney with stainless insertions.

5.4.5 CONNECTION TO THE ELECTRICITY MAINS

The boiler is connected to the electricity mains of 230 V/50 Hz/10 A by an electrical cord with plug. The mains input is type M and by replacing, it must be replaced with the same type by the service organisation. Appliance must be placed with easy reach of the plug. The boiler must be connected to the plug circuit with 10 A electrical circuit – breaker (following the STN EN 60 335 – 1 + A11:1997).

5.4.6 OPTION AND THE WAY OF CONNECTION OF THE CONTROL AND SAFETY ELEMENTS

Boiler is delivered with basic equipment, regulation and control elements. It is necessary to purchase other elements, which are not a part of delivery, but have to be installed in the heating system. It is especially, valve against exceeding permitted pressure (figure 4) in the heating system (we prescribe 2,5 bar), valve of the aftercooling loop of the boiler for draining excess warmth out of the boiler to the waste and bleeding valve for correct function of the boiler. Expansion tank in the system must have sufficient volume, which is set by the project architect of the heating system according to valid prescriptions. Electrical installation with sufficient equipment of the boiler has to be performed by the specialist according to valid norms.



CAUTION! Heating system has to be equipped with safety valve against exceeding pressure in the boiler (2,5 bar). We recommend to place this valve on the riser pipe of the boiler, always in front of the closing valve of the boiler (or in front of the OVENTROP). **If the safety valve would not be functional, excessive pressure would not be able to leak and boiler might explode!**

Pic. 4 Safety valve against overpressure

5.4.7 PROTECTION OF THE BOILER AGAINST OVERHEATING

Every gasifying boiler has to be equipped with functional aftercooling circuit. It is possible to order correct valve for ensuring this function, as accessory. In the figure 5 you can see correct installation of the aftercooling circuit valve.



CAUTION! Cooling circuit against boiler overheating can not be used according to the EN 303 – 5 norm for other purposes as is the boiler protection against overheating.

Valve at the inlet of cooling water to the cooling circuit of the boiler has to be permanently opened and cooling circuit of the boiler has to be connected to functional distribution of cold water (e.g. to distribution of cold water of the water network) of 10–15 °C temperature and operating overpressure 2–6 bar, which ensures safety operation even by electricity failure.

Thermostatic valve at the inlet of aftercooling circuit, which has sensor placed at the rear part of the boiler, protects the boiler against overheating. If the water temperature in the boiler rises above 95 °C, valve releases water from the water network in the cooling circuit which takes away excessive warmth. In case of boiler overheating and opening a thermostatic valve, permanent drain of warmed water from the cooling circuit of the boiler to the waste, has to be ensured. Functionality of the aftercooling circuit and thermostatic valve might be also checked manually, with the manual button of the thermostatic valve.

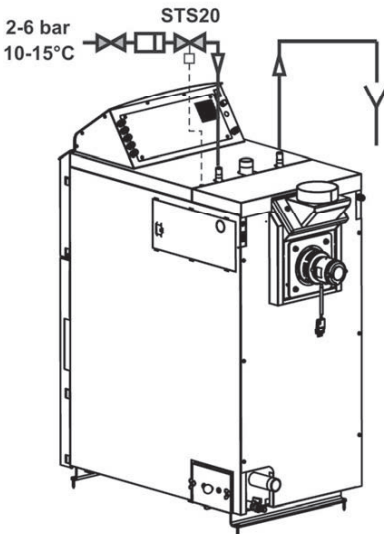

Pic. 5 The way of cooling circuit connection



CAUTION! If the circulation of cooling water through the aftercooling circuit would not be ensured during the opening of thermostatic valve, there is a danger of boiler damage. In this case is warranty not valid!

5.4.8 CONNECTION TO THE ACCUMULATION TANKS

System of the connection is based on warming the accumulation tanks, where is the accumulated warmth from accumulation tanks gradually drained according to the requirements of heated space. During the boiler operation at full output are accumulation tanks warmed at 80–90 °C. Heating with accumulation tanks in connection with ATTACK SLX boiler brings several advantages. Main advantages are higher efficiency, lower fuel consumption, prolonged lifetime of the boiler, more frequent operation, minimal creation of acids and condensates, higher comfort, lower risk of boiler overheating and fuel saving.

Recommended volume of the accumulation tank for ATTACK SLX 25 boiler is 2000 l (for other outputs see technical parameters). Boiler is able to produce 180 kWh of energy at one loading of the hard wood to the feeding chamber (it is ca. 7 hours of operation at full 25 kW output). It correspond to charge of 2 000 l accumulation tank from 20 °C to 90 °C if there is no energy offtake (that is why is necessary to keep in mind by choosing the size of accumulation tank, that boiler must be operated according to the size of accumulation tank. It means that, if you have 2000 l tank, load the wood chamber fully. If you have 1000 l tank, load the chamber halfway – if there is no energy offtake from the accumulation tank). If the accumulation tank is charged (bottom temperature of the accumulation tank achieves 70 °C) and boiler achieved set boiler temperature, do not load the wood to the boiler. If you would load the wood to the boiler in this state, wood would not be combusted (boiler has already achieved set temperature and fan has turned off). It would get dry and condensates would create in the feeding chamber, what lowers boiler lifetime. It is necessary to fill the wood at the time when the accumulation tank is almost discharged.

Example 1:

Outside temperature of the environment is –5 °C and heat loss of the object is 10 kW by this temperature. Boiler has 25 kW at the full output operation. Accumulation tank with volume 2000 l is discharged (its upper and bottom temperature is 20 °C). The heating system (to cover heat loss) drains 10 kW output from accumulation tank and boiler has 25 kW output, accumulation tank will be heated by the output of 15 kW – difference between them. 15 kW output makes energy of 105 kWh by full loading of the chamber with hard wood and time of the operation ca. 7 hours. Energy of 105 kWh warms accumulation tank from 20 °C to 65 °C. It means, that this is the safe economic operation without putting the boiler out of operation or draining excessive warmth to the waste (boiler was cooled by the aftercooling circuit). Boiler is able to cover the heat loss for up to 15 hours at one wood loading.

Example 2:

Outside temperature of the environment is +3 °C and heat loss of the object is 5 kW by this temperature. Boiler has 25 kW at the full output operation. Accumulation tank with volume 2000 l is discharged (its upper and bottom temperature is 20 °C). The heating system (to cover heat loss) drains 5 kW output from accumulation tank and boiler has 25 kW output, accumulation tank will be heated by the output of 20 kW – difference between them. 20 kW output makes energy of 140 kWh by full loading of the chamber with hard wood and time of the operation ca. 7 hours. Energy of 140 kWh warms accumulation tank from 20 °C to 80 °C. It means, that this is the safe economic operation without putting the boiler out of operation or draining excessive warmth to the waste. If the heat loss of the object would be constant all the time – 5 kW, charged accumulation tank would be able to cover heat loss for about 28 h, what is together with operation time up to 35 hours without need of wood loading.

That is why it is necessary to keep in mind, that boiler should be loaded **only with amount of wood** necessary for charging the accumulation tank, because pointless overheating might lead to putting the boiler out of the operation or removing excessive warmth to the waste. This is uneconomical and requires activation of the safety element – aftercooling loop.

5.4.9 SCHEMES OF BOILER CONNECTION TO THE ACCUMULATION TANKS

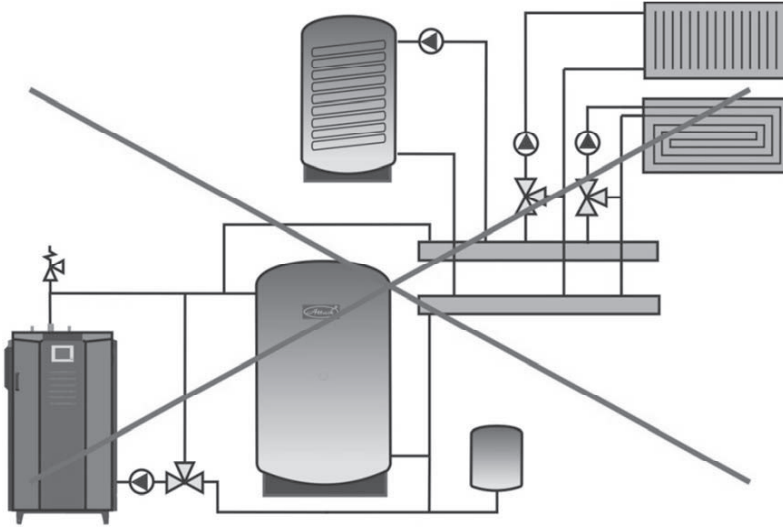

Scheme n. 1. – Incorrect connection, where is the heating circuit connected by the T connector in front of the accumulation tank

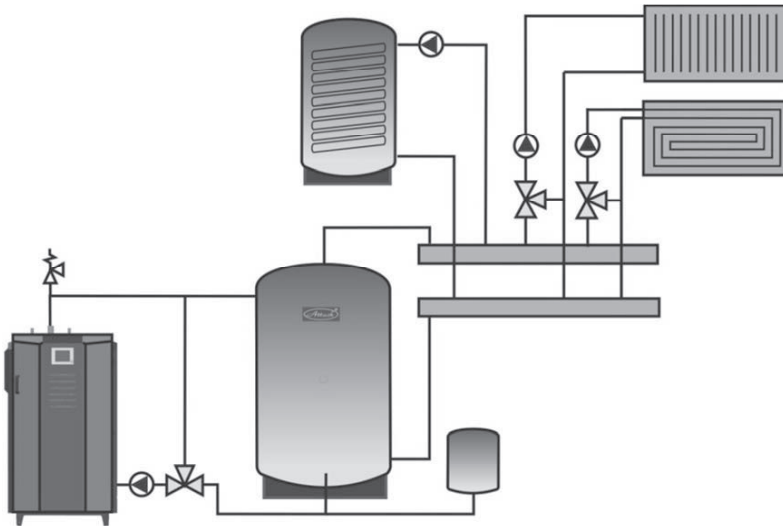

Scheme n. 2 – Correct connection of the gasifying boiler with accumulation tank, D.H.W. tank and mixing heating circuits (radiator and flooring)

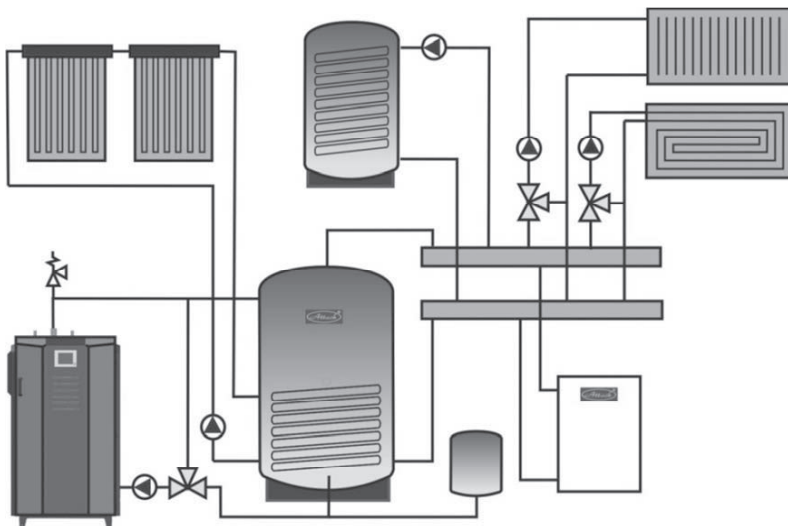

Scheme n. 3 – Connection of the gasifying boiler with accumulation tank with spiral for solar heating, D.H.W. tank, solar panels, mixing heating circuits (radiator and flooring) and automatic boiler (e.g. gas)

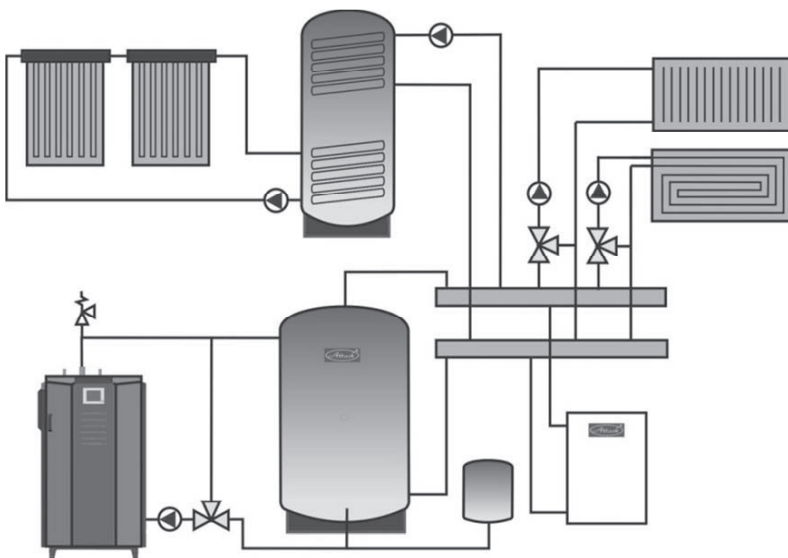

Scheme n. 4 – Connection of the gasifying boiler with accumulation tank, D.H.W. tank with spiral for solar heating, solar panels, mixing heating circuits (radiator and flooring) and automatic boiler (e.g. gas)

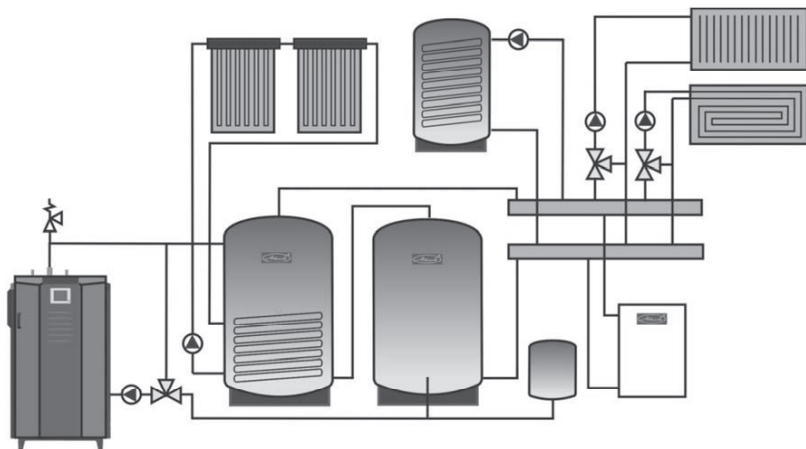

Scheme n. 5 – Connection of the gasifying boiler with two accumulation tanks

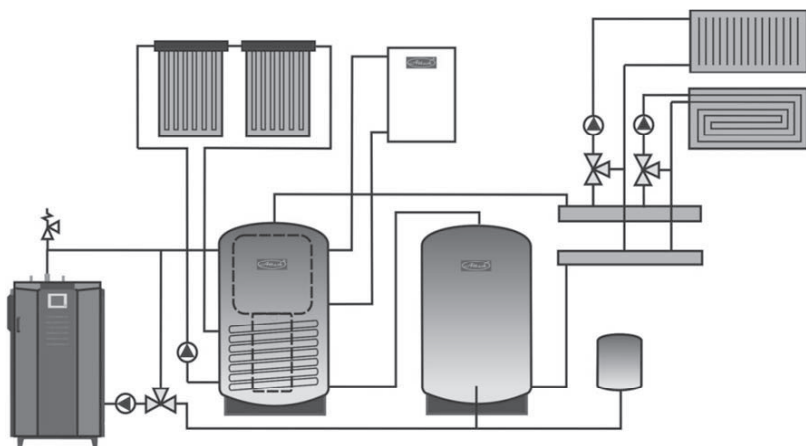

Scheme n. 6 – Connection of the gasifying boiler with combined accumulation tank

For other ways of connection, please visit web page www.attack.sk, where you can find wide range of options for connection to the heating circuits.

5.4.10 STANDARDLY DELIVERED ACCUMULATION TANKS ATTACK*

AK	AS	HR	HRS	TUV	TUVS	S	SS
200	200	—	—	—	—	—	—
300	300	—	—	—	—	—	—
400	400	—	—	—	—	—	—
500	500	600	600	500	500	500	500
800	800	800	800	600	600	800	800
1 000	1 000	1 000	1 000	800	800	1 000	1 000
1 500	1 500	1 250	1 250	1 000	1 000	1 250	1 250
2 000	2 000	1 500	1 500	1 250	1 250	1 500	1 500
2 500	2 500	2 000	2 000	1 500	1 500	2 000	2 000
3 000	3 000	—	—	2 000	2 000	—	—
4 000	4 000	—	—	—	—	—	—
5 000	5 000	—	—	—	—	—	—

AK – standard accumulation tank designed for accumulation of heating water

AS – accumulation tank for accumulating of heating water, equipped with a heating coil for connection to solar panels

HR – combined accumulation for accumulation of the heating water as well as for preparation of the D.H.W. by an internal enameled exchanger

HRS – combined accumulation for accumulation of the heating water as well as for preparation of the D.H.W. by an internal enameled exchanger, equipped with a heating coil for connection to solar panels

TUV – accumulation tank for accumulation of the heating water as well as for the D.H.W. preparation in a water coil

TUVS – accumulation tank for accumulation of the heating water as well as for the D.H.W. preparation in a water coil, equipped with a heating coil for connection to solar panels

S – accumulation tank with internal disk and stratification pipe (based on the type AK) that allows layering of water as necessary (different water temperature on inputs as well on outputs)

SS – accumulation tank with internal disk and stratification pipe (based on the type AS and S), equipped with a heating coil for connection to solar panels

* Required volume for required accumulation of energy is possible to cover one or several accumulation tanks. Accumulation tanks can be connected together to create required volume of accumulation water. Therefore, if you decided that your accumulation volume will be 2000 l, you can buy a single accumulation tank of 2000 l or two accumulation tanks with a capacity of 1000 l and connect them together.

5.5 BINDING NORMS FOR DESIGNING AND ASSEMBLY OF THE BOILERS

Boiler installation must be preformed in conformity with following norms:

STN EN 303 – 5:2012	Heating boilers for solid fuels
STN 73 42 10	Construction of the chimneys and flues
STN 92 0300	Fire safety of the local appliances and heat sources
STN EN 60 335.1 +A11	Safety of the electrical appliances for household
STN EN 12828+A1	Central heating, designing and installation
STN 06 08 30	Safety devices for central heating and D.H.W. heating
STN 07 74 01	Water and steam for thermal energetic devices with operation pressure of steam up to 8 MPa
STN 332000 4 – 46	Electrical installations of buildings – part 4: Ensuring safety
STN 332000–1:2009 – 04	Electrical installations of buildings – part 3: Definition of the basic characteristics
STN EN ISO 11202	Acoustics. Noise emissions of the machines and devices. Measuring the emissions levels of the acoustic pressure at the workplace and other precisely defined places by use of approximate corrections for environment (ISO 11202: 2010)
STN EN ISO 12100	Safety of machines. General principles of construction of machines. Considering and lowering the risk. (ISO 12100: 2010)
STN EN ISO 14120:2016	Safety of machines. Protective covers. General requirements for projecting and construction of the solid and movable covers.
STN ISO 27574 – 2	Acoustics. Statistical methods for determination and verification of the given noise emission value of the machines and devices. Part 4: Methods for machine series.
STN ISO 1819	Devices for continuous transportation of the freight. Safety prescriptions. General enactments
STN EN ISO 15614 – 1	Requirements for the quality of the fusible welding of the metal materials
STN 73 4210	Manufacturing the chimneys and flues and connection of appliances

6 BOILER OPERATION

6.1 OPERATING PRESCRIPTIONS



WARNING: Serious health or property damage might occur, if an unauthorised person enters the boiler room. An operator of the system have to secure the boiler room against the entrance of unauthorised people or children

Boiler preparation for operation

Ensure before putting the boiler into operation, if the system is filled with the water, bledded and if there is no decrease of the heating water pressure. Check if the chimney piping is tightly connected (the best bolted together) and if there wont be a smoke leakage. Check, if the manometer, boiler and safety thermostat sensors are placed in the boiler probes and if they show

real values. To achieve the correct function, boiler must be operated in compliance with the instructions given in this manual. During the boiler installation, underlay rear part for 10 mm, to ensure easier flush out and bleeding. Operation may be performed only by an adult, trained person with finished primary education.



WARNING: By the first heating up might occur condensation and leakage of the condensate – it is not failure. After longer heating condensation disappears. It is necessary to check the flue gas temperature during the combustion of small wood waste, which must not exceed 320 °C. In this case fan might get damaged. Partial creation of tar and condensates in the feeding chamber of the boiler is common attendant effect by the wood gasification and does not have negative influence on the boiler operation.

If the boiler was longer out of order (turned off, in failure), it is necessary to pay higher caution by restarting it up again. If the boiler was out of operation, there is possibility of pump blockage, water leakage out of system or boiler freezing in the winter period.

6.2 HEATING UP, OPERATION AND FUEL REFILLING

WOOD IGNITION

1. Open the door of the feeding chamber. Check height of the ash in the feeding chamber. If the height of ash exceeds 50 mm from the chamber bottom, clean the feeding chamber (figure 6). If there are wood coals in the chamber, it is not necessary to remove them, they make heating up easier. But it is always necessary to remove the ash. For cleaning is ideal to use fire poker and push the ash to the nozzle to make it fall to the combustion chamber (ashtray) of the boiler. **Clean the combustion chamber always before every heating in the boiler!**



Pic. 6 Correctly cleaned feeding chamber



NOTICE! If the combustion chamber would be insufficiently cleaned, volume of the combustion chamber would be rapidly lowered and it might lead to imperfect combustion and dangerous states. **Do not operate the boiler without cleaned combustion chamber by no means!**

- Put the refractory shaped brick, one layer of medium – thick logs (ca. 40–60 mm) into the feeding chamber, to not block the inlet of air to the nozzle and primary air. (figure 7)



Pic. 7 Basic layer of wood during heat – up

- Put the paper or cardboard (figure 8) on the prepared wood, or other suitable means for wood ignition (e.g. solid spirit firelighter)



Pic. 8 Put the twisted cardboard on the wood

- Put fine splinters on the cardboard or paper, which create basic layer (coals) after ignition, to ignite pieces of wood.



Pic. 9 Splinters for creating the basic layer

- Switch on the regulator. You can find the the way of starting up in part 6.3.4 – PROFI, 6.4 – LAMBDA Touch
- Ignite prepared layer at the bottom of front part (figure 10) and close the door partly for ca. 15 mm.



Pic. 10 Ignition of the basic layer

7. Wait 10–15 minutes until the basic layer sufficiently burn, to make it possible to stoke wood pieces (pic. 11)



Pic. 11 Sufficiently flaming basic layer

8. Stoke the wood pieces in full (figure 12)



Pic. 12 Stoking in full.

9. Close the door. Heat up is done. If you are not sure, whether heat up was successful or not, watch the flue gas temperature. If the heat up was done correctly, temperature of flue gas will rise

OPERATION

Boiler is during the common operation controlled according to several parameters depending on the boiler version (PROFI, LAMBDA Touch). It is ideal to operate the boiler on 100 % output. Boiler achieves the highest efficiency, stability of burning, minimal wastes from burning and trouble –free operation. This type of operation is best achievable when is the boiler connected to the accumulation tank with suitable volume, which is gradually charged. Difference between set boiler temperature and temperature of the reverse must be minimally 15 °C to not let boiler achieve set boiler temperature during the charging of accumulation tank. Otherwise the boiler would put to the sustain mode before charging the accumulation tank. Operation and boiler control is described more in details below, according to the boiler version PROFI or LAMBDA Touch.

FUEL REFILLING



CAUTION! Door of the feeding chamber has to be opened gradually during the operation, to not let potential smoke which comes out of the chamber hit your eyes.

Refill the fuel only when the wood is almost consumed and in the feeding chamber are only coals. (figure 13). We do not recommend to refill the wood during the common operation, when is the chamber filled for more than 1/5 of its volume, because in the chamber takes place the pyrolysis without the oxygen inlet, which creates the smoke and it is not possible to suck it out well after you open the door. Perform refilling by opening the door partly (ca. 15 mm), wait until the smoke will be sucked out and open the door fully. Then stoke the wood to the chamber as fast as possible. Wood has to move in the feeding chamber freely and between each log has to be at least 1–2 cm space. You can close the door after stoking the wood to the chamber



Pic. 13 Height of the live coals suitable for stoking.

LAMBDA Touch version of the boiler can keep remaining coals longer, because after burn out of the fuel is closed the flap of primary air by the servoengine, what prevents their burning out. In this way is possible to keep coals up to 24 hours and make the futher heat up easier.

6.2.1 PROTECTIVE TOOLS FOR WORK WITH THE BOILER

It is necessary to use the protective tools according to valid regulations of the work safety, during the work with the boiler. During the operation, cleaning and inspection of the boiler is necessary to pay attention to protection of the health. It is necessary to use gloves with higher fire-proofness, eligible clothes and hard shoes.

6.3 CONTROL OF THE ATTACK SLX PROFI BOILER

Boiler regulation offers high comfort of the control, possibility of output modulation and possibility of connection of the control and regulation elements. Regulator controls the operation on the basis of boiler and flue gas temperature. Regulator tries to achieve required boiler temperature by set temperature of the flue gas, which is controlled by changing the fan rotations. In this way regulator ensures, that temperature of the boiler will be reached by as high as possible efficiency. If the temperature of the boiler is coming near to the set value, regulator modulates output of the boiler. If the set boiler temperature is reached, regulator switches the fan off.

Connection

Connect the regulator, fan, circuit pump and supply cords to appropriate plugs in the rear part of the device before switching on the device by main switch. Sensor of the boiler temperature has to be placed in the boiler probe.



CAUTION! Before connecting the regulator to the electricity mains, check, if it is properly grounded and screws of the clamp are tightened enough.



WARNING: Maximal total output of devices connected to the regulator can not be higher than 700 W.



WARNING: It is possible to connect UM – 1 module for expanded function of regulator, which allows to control switching on of other automatic boiler.

6.3.1 ADVANTAGES OF REGULATOR

Regulator is able to control:

1. Rotations of the exhaust fan
2. Circuit pump of heating circuits
3. Pump of D.H.W. charging or pump of accumulation tank charging (always only one)
4. Switching on the other, automatic boiler in case of fuel burn out in the boiler. (module UM – 1 delivered as accessories)

Regulator is able to scan:

1. Boiler temperature
2. Flue gas temperature
3. Temperature in the D.H.W. tank or in the accumulation tank (always only one)
4. Room thermostat and on the basis of its switch on, controls circuit pump.

6.3.2 BASIC DESCRIPTION OF THE REGULATOR

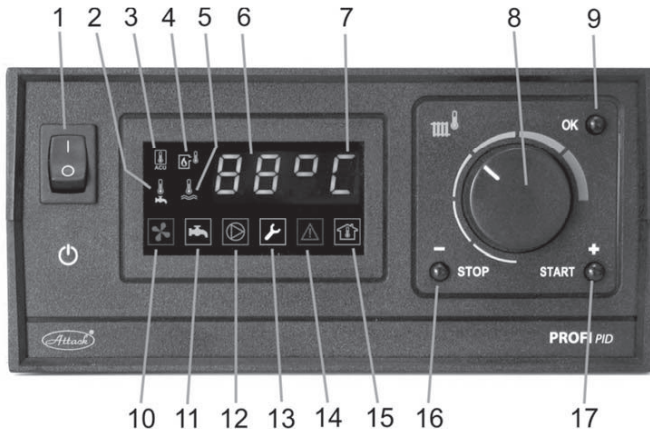

Pic. 14 Particular buttons and displaying the information on the regulator

1. main switch
2. icon for D.H.W. temperature indication
3. icon for temperature of accumulation tank indication
4. icon for flue gas temperature indication
5. icon for current boiler temperature indication
6. current boiler temperature (or temperature of D.H.W., flue gas, etc.)
7. symbol, which informs about the operating mode of the boiler
8. setting the boiler temperature
9. button to enter to the information menu, service menu and confirmation of parameters
10. icon displaying fan operation
11. operation of the pump for D.H.W. or of the pump for the accumulation tank charging
12. icon displaying circuit pump operation
13. icon displaying entrance to the service menu
14. icon indicating overheating or sensors damage
15. icon indicating that the room thermostat is turned on
16. button to stop the boiler or to move backward in menu
17. button to start the boiler or to move forward in menu

6.3.3 CONNECTION OF THE PROFI PID REGULATOR BY HYDRAULIC SCHEMES

The regulator can control several types of hydraulic schemes. Parameters in the service menu must be correctly set adequately to the type of the hydraulic scheme.

Note: The additional thermal sensor for controlling the additional output is connected by production and it is rolled in the control panel of the boiler. To use the sensor, it is necessary pull it out from the control panel through the prepared plastic bushing. This action can be performed only by a qualified person or by a person trained by producer. Regulator is set by production for the simplest control of heating circuit according to the scheme 7. Schemes show connection of pumps and sensors. There is not shown connection of the fan and connection to the mains on the schemes.

Scheme 7: Gasifying boiler + heating circuit

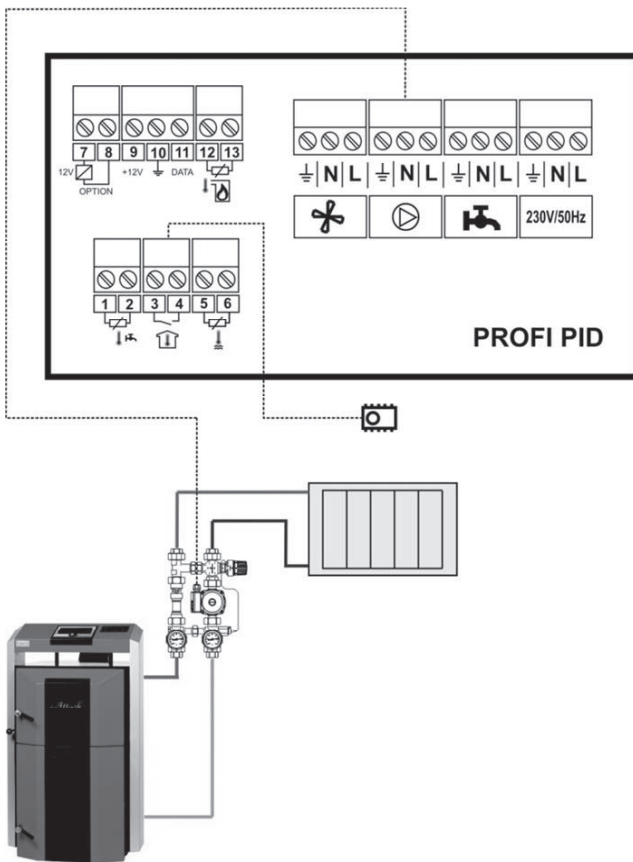

Setting parameters for hydraulic scheme 7:

ur = ur0

Scheme 8: Gasifying boiler + heating circuit + D.H.W. charging

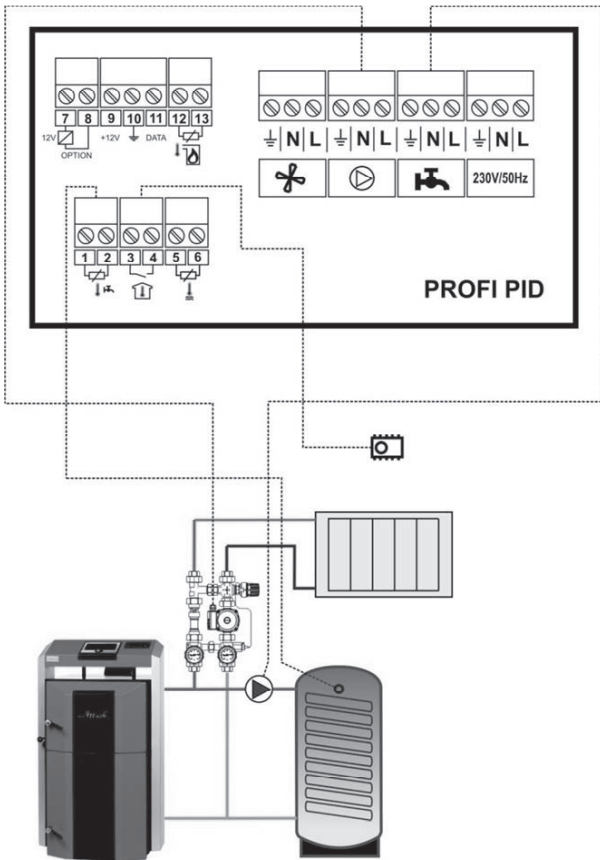

Setting parameters for hydraulic scheme 8:

ur = ur1 – for priority charging of D.H.W. tank
 ur = ur2 – for parallel charging of D.H.W. tank

Scheme 9: Gasifying boiler + heating circuit + charging of accumulation tank

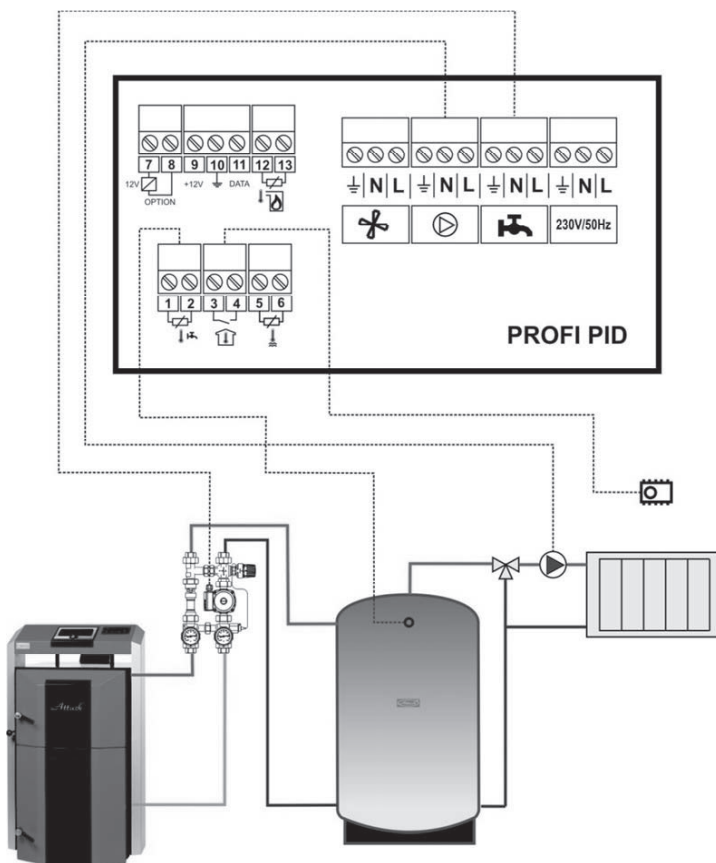

Setting parameters for hydraulic scheme 9:

ur = ur4

Scheme 10: Gasifying boiler + heating circuit + charging of accumulation tanks connected in serie

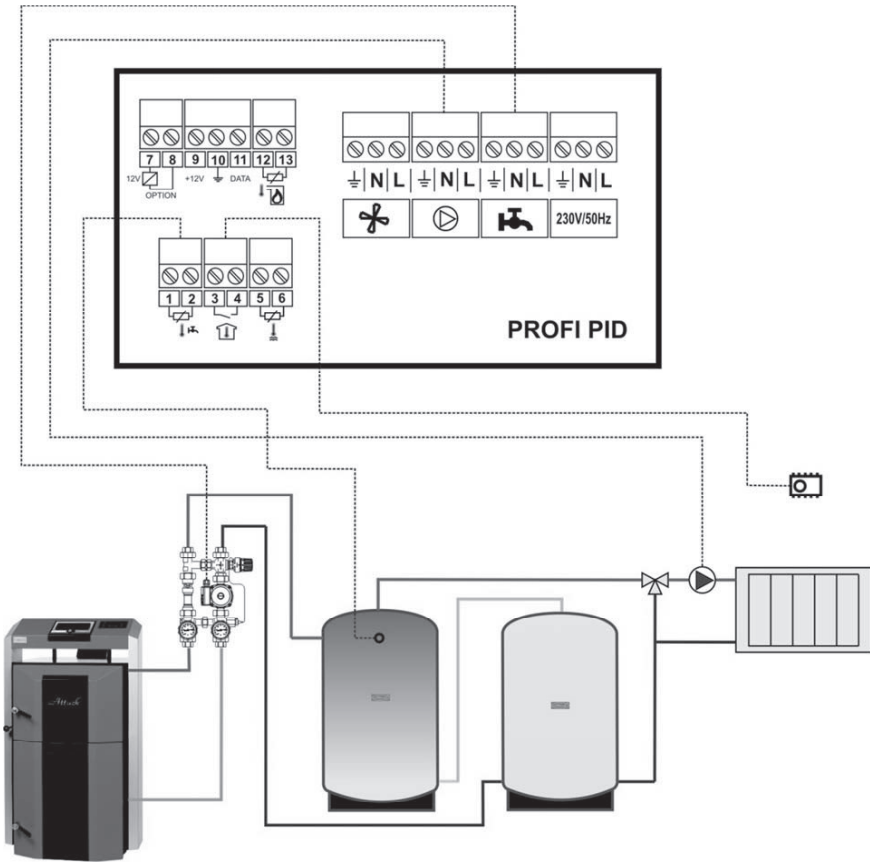

Setting parameters for hydraulic scheme 10:

ur = ur4

Scheme 11: Gasifying boiler + heating circuit + charging of combined accumulation tank

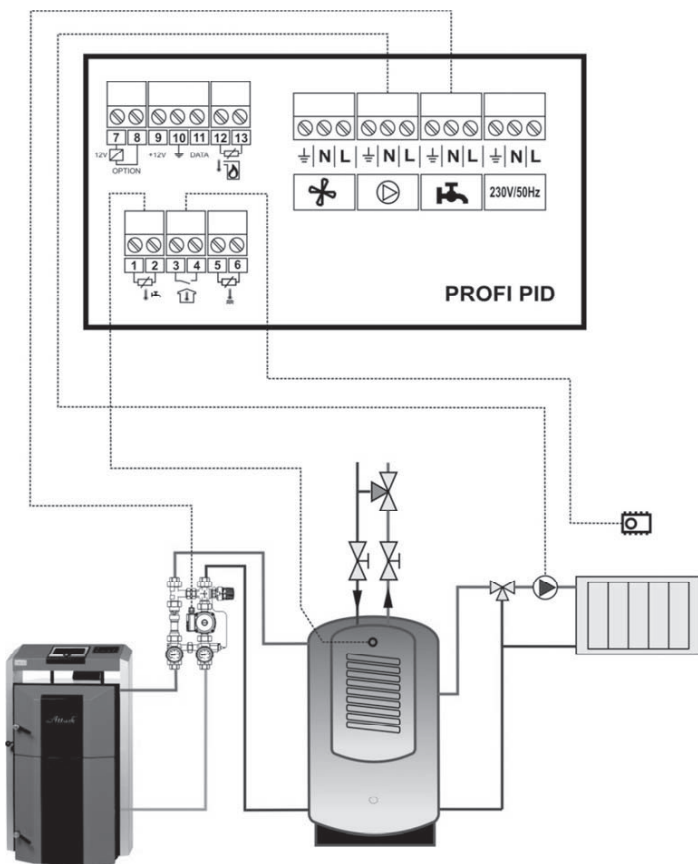

Setting parameters for hydraulic scheme 11:

ur = ur4

6.3.4 REGULATOR CONTROL AND OPERATING MODES

By turning on the main switch are shown on the display all icons for responsible check of their functionality. If the regulator gets suddenly disconnected from electricity mains (e.g. by power failure), regulator returns to the last mode, by which the interruption of electricity supply occurred. Regulator saves all the settings even after the power failure.

Basic control of the regulator lay in setting the boiler temperature by the knob. Other functions are controlled on the basis of service parameters set in service menu.

The boiler is turned on by pressing the START (17) button that starts the operation of exhaust fan. The STOP (16) button put the boiler out of operation by turning the exhaust fan off.

The sign displayed behind the numeric temperature indication (7) indicates the current mode of the PID regulator

[50°-] – indicates the stand – by mode

[50 °C] – indicates the winter operating mode

[50 °C] – indicates the winter operating mode when the boiler temperature is achieved

[50°U] – indicates summer operating mode intended only for D.H.W. warming

[50°u] – indicates summer operating mode when the boiler temperature is achieved

[70°d] – indicates mode of elimination of the legionella bacteria, when the temperature of D.H.W. is increased to 75 °C

[50°P] – indicates that regulator is blocked by pellet burner of the COMBI Pellet boiler or connection between clamps 10 and 11 is incorrectly connected.

The PROFI PID regulator has an advantage of regulating the flue gas temperature to the set, required value. Regulator tries to achieve set flue gas temperature and after reaching this temperature is switched to the mode of reaching the required boilers temperature. Thereby is the fuel used in the most effective way and also high efficiency is ensured.

6.3.5 SETTING THE USER PARAMETERS

The menu for displaying and setting the user parameters is accessible after short press of the OK button. The „+“ and „-“ buttons are used to browse in settings and parameters. After selecting appropriate parameter is possible to enter to this parameter by pressing the OK button. Successful entrance to this parameter is signalized by flickering of this parameter. Then setting can be changed by the „+“ and „-“ button and confirmed by „OK“ button. Some of the parameters are only informative and they can not be changed. To exit the menu, confirm the [End] by „OK“ button. After remaining more than 1 minute without the user’s intervention, the regulator switches to the basic display.

Table 1. User parameters:

Display	Parameter	Min	Max	Step	Fac. sett.
C 45	Set boiler temperature	L65	H95	1 °C	–
co C	Operating mode of the circuit pump ('C' – WINTER, '–' – SUMMER)	C	–		C
cu u	Operation of the D.H.W. pump ('u' – common mode, 'd' – elimination of legionella bacteria)	u	d		u
u50°	Current temperature measured in the accumulation tank or D.H.W. tank				
150°	Current flue gas temperature				
End	Exit from user parameters				

[C 45] – Adjusted boiler temperature – this is the value of the water temperature in the boiler, which should be reached by the boiler in work mode. It is set by turning the knob manually (8) and shown on the display (6).

[co C] – WINTER/SUMMER mode – the winter mode is indicated by the 'C' letter. In this mode is the circuit pump controlled by the room thermostat and distributes heat into the heating circuit. The summer mode is indicated by the „–“ symbol. In the summer mode is the circuit pump out of order and the heat generated by the boiler is only used to charge the D.H.W. tank. If there is not D.H.W. tank in the system (additional sensor is not connected), it is not possible to select the SUMMER / WINTER mode.

[cu u] – Mode of D.H.W. tank charging – regulator enables common D.H.W. tank charging „u“ or the mode with elimination of the legionella bacteria „d“. After selecting „d“ mode , the temperature of 75 °C is achieved in the D.H.W. tank. When is this temperature achieved, regulator switches in the mode of the common D.H.W. tank charging „u“. The option of elimination the legionella bacteria is not available, if the additional outlet and sensor are not set for the D.H.W. charging.



CAUTION! To not to get hurt by the hot water, it is recommended to start this mode, when the D.H.W. is not being used (e.g. during the night).

[u50°] Temperature of additional sensor – this is the value of current temperature of the D.H.W. tank or temperature of the accumulation tank of the heating system. This temperature is not displayed in the user menu, in case, that the additional output is not used.

[150°] Flue gas temperature – this value represents current temperature of flue gas, if the parameter for flue gas temperature control is set in the service parameters

6.3.6 SETTING THE SERVICE PARAMETERS

By holding the OK button you get access to the service menu to the parameter settings. The buttons „+“ and „-“ are used to browse between particular parameters. After selecting the appropriate parameter, confirm it by „OK“ button and it starts to flicker. By using the „+“ and „-“ buttons is possible to change the setting of appropriate parameter. To confirm the set parameter, press the OK button. To exit the service menu, confirm the [End] by „OK“ button. After remaining for more than 1 minute without the user’s intervention, controller switches display to the basic mode.

Table 3. Service parameters:

SERVICE MENU (available by holding the OK button)					
Display	Parameter	Min	Max	Step	Prod. set.
П100	Maximum fan output	1	100	1 %	100
n 40	Minimum fan output	1	100	1 %	40
Пh 5	Ratio of change of the fan rotations	2	20	1	5
Пr 0	Automatic regulation of change of the fan rotations	– , 0	10	1	0
Пt 1	Delay of change of the fan rotations	0	99	1	1
Пn 5	Frequency of exhaust fan blow – through	– – , 5	60	1 s	5
Пu 6	Duration of exhaust fan blow – through	1	99	1 min	6
Пd3	Duration of manual fan operation for 100 %	– – , 1	99	1 min	3
r100	Fan output by ignition	1	100	1 %	100
rh 5	Hysteresis of boiler stop by ignition	1	45	1 °C	5
P 30	Temperature for starting the circulatory pump	– – , 20	70	1 °C	30
Ph 2	Hysteresis of circuit pump	1	40	1 °C	2
Pc – –	Interval of unblock function of circulatory pump	– – , 1	99	1 min	2
Ur0	Operation of additional output	0	4	1	0
u30	Operating temperature of D.H.W. tank or accumulation tank	30	60	1 °C	30
uh 5	Hysteresis of D.H.W. tank or accumulation tank	1	30	1 °C	5
uP 5	Boiler temperature increase by D.H.W. warming	1	20	1 °C	5
L65	Minimum boiler temperature	30	65	1 °C	65
H 85	Maximum boiler temperature	80	95	1 °C	85
h 2	Boiler temperature hysteresis	1	10	1 °C	2
A 99	Temperature of boiler overheating	90	99	1 °C	99
Fd60	Duration of boiler stop by ignition and fuel shortage	– – , 1	99–4 h	1 min	60
Fb30	Duration of boiler stop by flue shortage and burn – down	– – , 1	99–4 h	1 min	30
Ar 0	Control of multifunctional additional output	0	1	1	0
° 240	Set flue gas temperature	– 0,5	250	1 °C	240
° h5	Flue gas temperature hysteresis	1	99	1 °C	5
° t 5	Time constant of stabilization the flue gas temperature	1	99	1 min	5
° F10	Blower speed jump while stabilizing flue gas temperature	1	20	1 °C	10
° 90	Flue gas temperature by fuel shortage	30	150	1 °C	90
° 300	Maximum flue gas temperature	250	400	1 °C	300
Prod	Return to the production settings				
outП	Test of fan relay	outП	out1		
outP	Test of circulatory pump relay	outP	out2		
outu	Test of optional pump relay	outu	out3		
outr	Test of additional output	outr	out4		
End	Exit to main menu				

6.3.7 DESCRIPTION OF PARAMETERS

[P100] Maximum fan output – the highest allowed fan output

[n 40] Minimum fan output – the lowest allowed fan output

[Ph 5] Ratio of change of the fan rotations – this parameter influences lowering the fan rotations, if the set boiler temperature is going to be achieved in a short time. For example, if the value 4 is set, the fan will work at maximum output [P100] (if the function of flue gas temperature control is not active), up to 4 degrees before achieving the set boiler temperature. Then, by every increase of the boiler temperature for 1 °C, the fan rotations are gradually decreased until the minimum fan output [n 40] is reached.

[Pr 0] Automatic regulation of change of the fan rotations – the fan rotations are increased / decreased by setting this parameter within the range of 0–10 to ensure the required boiler temperature. If this parameter is set to „ – “, regulation of rotations is not active and the fan works always at full output according to the parameter [P100]. Setting the parameter within the range of 0–10 relates to the time period (in minutes), during which are the fan rotations gradually increased from the parameter of the minimum fan rotations [n 40] up to the parameter [r 100]. This ensures fluent heat – up of the boiler.

[Pn 5] Frequency of exhaust fan blow – through – this frequency defines, how often has to be the fan started to the full output operation [P100] to take the flue gas out from the boiler, if the fan was stopped due to achievement of boiler temperature.

[Pu 6] Duration of exhaust fan blow – through – during this period must the fan exhaust the flue gas following the parameter [Pn 5].

[r 100] Fan output during ignition – this parameter defines the fan output by boiler heat – up. If the parameter " Pr " is set to [Pr 0], then this parameter is not available.

[rh 5] Hysteresis of boiler stop during ignition – defines, how many degrees before reaching the set boiler temperature is the heat – up phase deactivated or (if the flue gas temperature sensor is connected), how many degrees before reaching the set flue gas temperature. Deactivation of heat up phase leads to the switching to common operation mode.

[P 30] Temperature to start the circulatory pump – if there is not D.H.W. tank in the system [ur 0] or it is in the mode [ur 2], then the parameter defines the boiler temperature for starting the circulatory pump of the heating system. If the parameter is set to „ – “, then too low temperature does not influence the operation of the circulatory pump. Anyway, the pump always starts, when the boiler temperature exceeds the parameter [H 85] of the maximum boiler temperature. If there is accumulation tank in the heating system (parameter [ur 4]), then this parameter defines the temperature measured in the accumulation tank by which is the circulatory pump of the heating system started on.

[Ph 2] Hysteresis of circulatory pump – defines the temperature difference, below which must the boiler temperature or temperature in the accumulation tank decrease in comparison with the temperature defined by the parameter [P 30] to stop the circulatory pump.

[Pc - -] Interval of antiblocking function of circulatory pump –when is the regulator in stand – by mode or the room thermostat is disconnected, the circulatory pump is started for 30 seconds after each [Pc - -] minutes to prevent the pump blockage caused by its inactivity. The antiblocking pump function is deactivated, when the Pc is set to „ - -“.

[ur 0] Operation of the additional output – this parameter defines the operating mode of the additional output (pumps for D.H.W. tank charging or accumulation tank).

[ur 0] Additional output without function – defines that additional sensor and pump are not connected and additional output is not used in this case.

[ur 1] Priority charging of D.H.W. tank by this setting is the pump for D.H.W. tank charging connected to the additional output and the sensor of this tank is connected to the additional inlet. Then, if the temperature in the D.H.W. tank drops below the value of hysteresis

[uh 5] from adjusted temperature [u 60], the pump of D.H.W. tank charging starts its operation. When the temperature in the D.H.W. tank reaches the set value [u 60], the pump is put out of operation. The pump is also stopped, when the temperature in boiler is lower than the temperature in D.H.W. tank. The [ur 1] mode means that the D.H.W. preparation has priority, i.e. the circulatory pump of the heating circuit is started, after charge of D.H.W. tank.

[ur 2] Parallel charging of the D.H.W. tank – works similar to the [ur 1] setting, but D.H.W. is prepared in the parallel mode of joint operation with the circulatory pump of the heating circuit.

[ur 3] Not in use

[ur 4] Charging the accumulation tank – this setting defines, that the additional output serves as a pump of charging the accumulation tank and the additional sensor measures its temperature. In this mode, if the temperature in the boiler exceeds the hysteresis [uh 5] over the current temperature of accumulation tank, the pump for charging is put into operation. The pump is stopped, if the temperature in the boiler is same or lower than the temperature in the accumulation tank, or when the temperature in boiler drops below the minimum boiler temperature defined by the parameter [L 65].

[ur 30] Operating temperature of the D.H.W. tank or accumulation tank – temperature to control the additional output [ur].

[uh 5] Hysteresis of the D.H.W. tank or accumulation tank – this parameter defines hysteresis of the additional output [ur].

[urP 5] Boiler temperature rise during D.H.W. warming – this parameter is relevant, when additional output works in the mode of D.H.W. tank charging. It defines, for how many degrees will be set boiler temperature higher than parameter [u 50] during the D.H.W. tank charging.

[L 65] Minimum boiler temperature – defines the minimum boiler temperature that can be set by the knob.

[H 85] Maximum boiler temperature – defines the maximum boiler temperature that can be set by the knob.

[h 2] Hysteresis of boiler temperature – defines the difference between set and the current boiler temperature for which must the boiler temperature decrease to start the regulator again after the set boiler temperature is achieved.

[A 99] Temperature of boiler overheating – defines the value of boiler temperature to activate the alarm of the boiler overheating.

[Fd60] Duration of the boiler stop by ignition and fuel shortage – this parameter defines the maximum time between starting the regulator by the START button and achieving the regulator's operating mode (reaching the flue gas temperature of [° 90]). If the temperature of [° 90] is not reached during the heating up, fan is stopped and the alarm FUEL (fuel shortage) is displayed.

[Fb30] Duration of the boiler stop by flue shortage and burn – down – the fuel amount test is activated in the operating mode, when the flue gas temperature drops below the parameter [° 90] or (if the flue gas sensor is not connected) when the boiler temperature drops below the set parameter [L 45]. If the temperature does not exceed the necessary limit during this period, regulator displays FUEL alarm.

[Ar 0] Controlling of the multifunction additional output – regulator has additional multifunction output which is compatible with options mentioned below (for controlling these options is necessary to use additional module UM – 1):

- **[Ar 0] parameter** – indicates start up of the automatic boiler (e.g. gas or pellet boiler). When is the regulator started and gasifying boiler generates heat, the automatic boiler is put out of operation. Operation of the automatic boiler is blocked by the regulator in the operating mode. Regulator put automatic boiler into operation, if the fuel is burned down in the boiler and the FUEL alarm is displayed.
- **[Ar 1] parameter** – indicates that the additional multifunction output will be used for signalization of error messages like boiler sensor failure, overheating or fuel shortage.

[° 240] Adjusted flue gas temperature – is the flue gas temperature, the regulator will struggle to reach and keep this value. The flue gas temperature sensor is turned off, if this parameter is set to „ – – “.

[° h5] Hysteresis of flue gas temperature – defines the difference, for which must the flue gas temperature decrease, to increase the fan rotations.

[° t 5] Time constant of stabilization the flue gas temperature – defines the period of adjusting the fan rotations during the stabilization of the flue gas temperature. If the flue gas temperature exceeds the value given by the parameter [° 240], regulator starts to decrease the fan rotations gradually, until the flue gas temperature decreases to the adjusted value. If the flue gas temperature decreases to the value of flue gas temperature hysteresis, regulator starts to increase the fan rotations gradually.

[° F10] Fan rotations step of stabilization the flue gas temperature – defines the value of fan rotations step, for which will regulator change the rotations of the fan to achieve the adjusted flue gas temperature.

[**c 90**] **Flue gas temperature of fuel shortage** – status „FUEL“ for fuel shortage is displayed after the flue gas temperature drops below this value.

Testing the outputs of regulator

It is possible to make a test to check the correct functionality of the regulator and devices connected to the regulator. Correct function of the fan is tested by selecting the [**outF**] on display and holding the „OK“ button. Test of the circulatory pump is done by selecting the [**outP**]. Select the [**outu**] to start the additional output and [**outr**] for multifunction additional output

Putting the regulator to original, production settings

There is a possibility to reset the regulator and change the settings to original, production settings by selecting the [**Prod**] in the service menu and confirming by „OK“ button. Then is the regulator set to the values given in the Table 3.

Exit from service menu

Select the [**End**] on display and press the „OK“ button to exit from service menu.

6.3.8 ERROR MESSAGES

Connection of all sensors of the regulator is constantly checked.

If the regulator detects that some of the sensors is not connected, the error messages are displayed. Messages about the boiler overheating or fuel shortage are also displayed.

[**FUEL**] – is displayed, when there is not enough fuel in the boiler. The sufficient amount of fuel is defined by the parameter ^c90, where the figure 90 is related to the set value 90 °C. Then, if the flue gas temperature decreases below this set value within the time Fb30 (time of boiler stop by fuel shortage), the regulator displays [FUEL] message. To put the boiler in the operation mode again, it is necessary to remove the message by the STOP button and then to press START to start the boiler.

[**HOT**] – is displayed, when the flue gas temperature exceeds the maximum permitted value set by the parameter c300 (means 300 °C). The fan is stopped in this case. After the temperature decreases to the adjusted flue gas temperature, the fan is started again.

[**E 1**] – is displayed, when it comes to the boiler temperature sensor failure or when is sensor not connected. In such case is the regulator taking actions to ensure the safety of the boiler – the fan is put out of operation (if it is currently in operation) and the circuit pump is started for eventual safe boiler cooling. When is the cause of error removed, the error message can be canceled by the STOP button.

[**E 2**] – is displayed, when the boiler temperature exceeds the boiler overheating temperature A99. In this case regulator turns off the exhaust fan and starts the circulatory pump. The error message can be removed by the STOP button after the boiler temperature decreases to the safe value.

[**E 8**] – is displayed, when it comes to the additional sensor failure (in the D.H.W. tank or accumulation tank). If this sensor works as the D.H.W. tank sensor, charging is blocked. If the sensor works for the accumulation tank, the pump permanently works. It is not necessary to remove this error by the STOP button. It is removed automatically after the sensor failure is removed.

[E128] – is displayed, when the flue gas temperature sensor fails. In this case is regulator switched to the mode of controlling the boiler according to the boiler temperature. Error message is removed automatically, when is the failure of flue gas temperature sensor removed.

[E 3] If several failures occur in one moment, their total is displayed on the screen. In such case is necessary to check the functionality of all sensors.

6.3.9 DISASSEMBLY OF THE REGULATOR

If it is necessary to disassemble the regulator, do the following:

- turn the main switch off
- disconnect the boiler from electricity mains
- dismount the regulator
- dismount connectors from the regulator

6.3.10 TECHNICAL SPECIFICATION OF THE REGULATOR

Power supply	230 V \pm 10 %, 50 Hz
Input (not including the fan and pumps)	< 4 VA
Range of measuring the boiler temperature	-9-109 °C \pm 1 °C
Range of measuring the flue gas temperature	-30-500 °C \pm 1 °C
Max. input of devices connected to the regulator	2 A/230 V

6.3.11 SETTING THE AIR FLAPS AND FLUE GAS TEMPERATURE

Setting the combustion of the PROFI boiler.

Combustion setting is performed by the regulation flaps of the primary and secondary air. Boilers are set by the production for the most optimal conditions of burning from the point of view of emissions and flue gas temperature. Change of the settings might be performed only by the service trained by the producer.

Optimal setting of the primary/secondary air flaps and temperature of the flue gas for PROFI version:

Type	Primary/Secondary	Flue gas temperature	Type	Primary/Secondary	Flue gas temperature
20SLX	100/55	165 °C	40SLX	100/65	160 °C
25SLX	100/65	170 °C	45SLX	100/75	165 °C
30SLX	100/60	175 °C	50SLX	100/80	175 °C
35SLX	100/70	180 °C	55SLX	100/85	185 °C

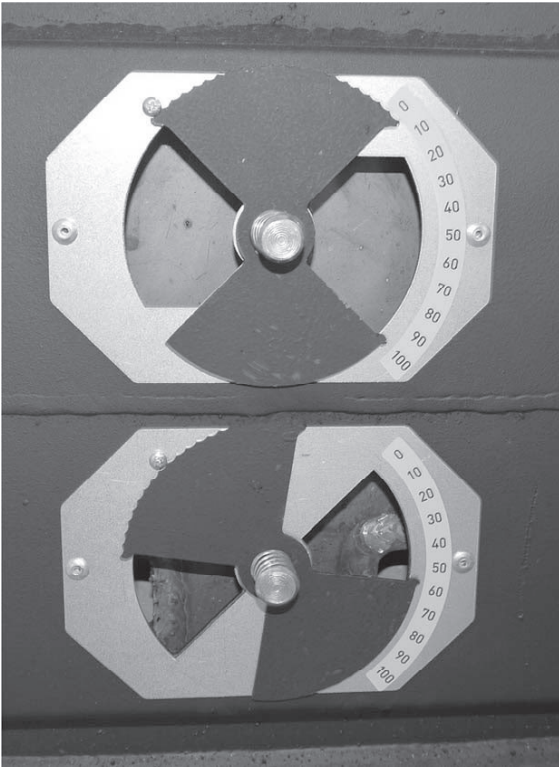

Pic. 15 *Setting flaps of primary and secondary air*

Primary air adjustment to 100 %

Secondary air adjustment to 55 %

Setting the flue gas temperature is described in the chapter **6.3.7 DESCRIPTION OF PARAMETERS.**

6.4 ATTACK SLX LAMBDA TOUCH BOILER CONTROL

Controlling process of the combustion in the ATTACK® SLX LAMBDA Touch boiler is ensured by modern electronics with software, which works on the basis of the newest knowledge about wood combustion. Electronics works with lambda probe and advanced touch screen, which displays several information in one go. This allows fast identification of the boiler state and its parameters.

6.4.1 BASIC CONTROL ELEMENTS

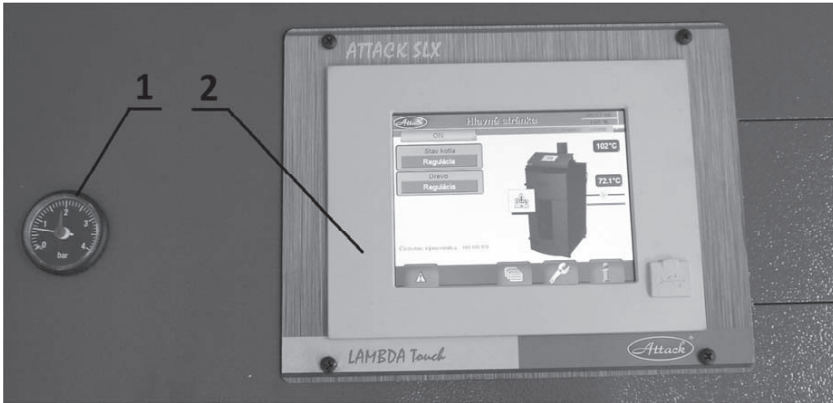

Pic. 16 1 – manometer, 2 – touch screen



Pic. 17 1 – main switch, 2 – emergency thermostat, 3 – fuse (F6,3 A)

6.4.2 WORKING METHOD OF LAMBDA TOUCH CONTROLLER

Boiler is controlled on basis of oxygen volume in the flue gas, boiler and flue gas temperature. Boiler tries to reach set boiler temperature by ideal temperature of the flue gas and oxygen. Regulator controls the boiler output by changing the fan rotations and primary air, to ensure achievement of the set boiler temperature as precisely as possible. If the boiler achieves set value of the boiler temperature (e.g. 80 °C), regulator does not turn off the fan, but lowers its rotations. Rotations are lowered until the boiler reach minimal flue gas temperature, what leads to lowering of the output to 50 %. If the boiler temperature exceeds set temperature for „differential temperature of max. boiler temperature exceeding“, boiler turns off the fan and closes the primary air, what leads to the output lowering to the minimum. Boiler turns on again, when actual boiler temperature drops below the set boiler temperature that is lowered for hysteresis of the boiler temperature. During this control process is also controlled the volume of oxygen in the flue gas, to ensure the most effective combustion. Boiler is turned off totally, when is evaluated according to the flue gas temperature and oxygen, that the fuel in the boiler is burned out. Then boiler closes primary air. Thanks to this might coals which remained from combustion, hold on next 24 h. It is possible to make in this way next heat up of the boiler even without making a fire and without the use of tools for ignition. In the case, that boiler temperature exceeds 85 °C, is pump always turned on for safety reasons. In the case, that boiler temperature exceeds the breaking temperature of the emergency thermostat, all electronic devices of the boiler, except pump, will be put out of operation. You might see the basic displaying in the figure 18.

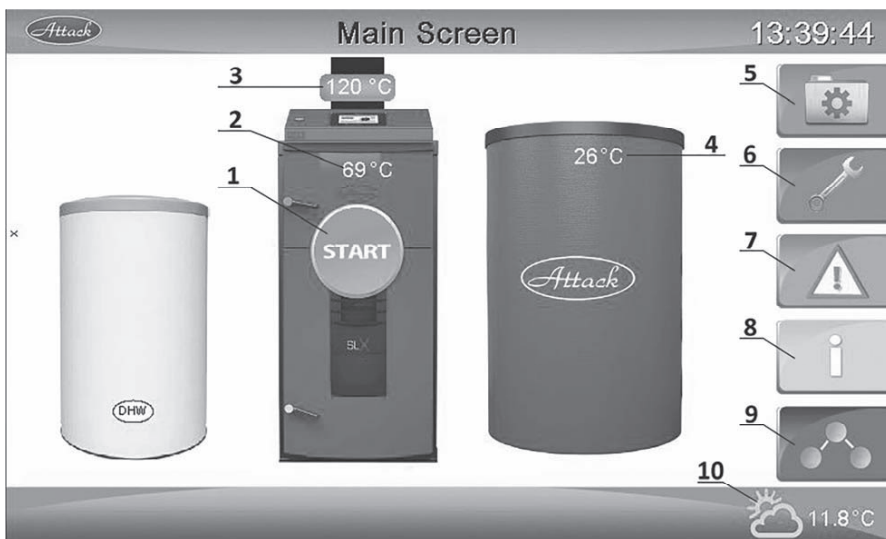

Pic. 18 Basic displaying

1 – Start of boiler, 2 – Boiler temperature, 3 – Flue gas temperature, 4 – Temperature of accumulation tank (optional sensor), 5 – Menu settings of parameters, 6 – General settings, 7 – Error messages, 8 – Information menu, 9 – Heating circuit, 10 – Outside temperature (optional sensor)

6.4.3 TESTMODE

Testmode of boiler (TEST) enables test functionality of all connected electrical devices. Click the button of General settings (Pic. 19) and then the button TEST for the entry into the Testmode of the boiler (Pic. 20).

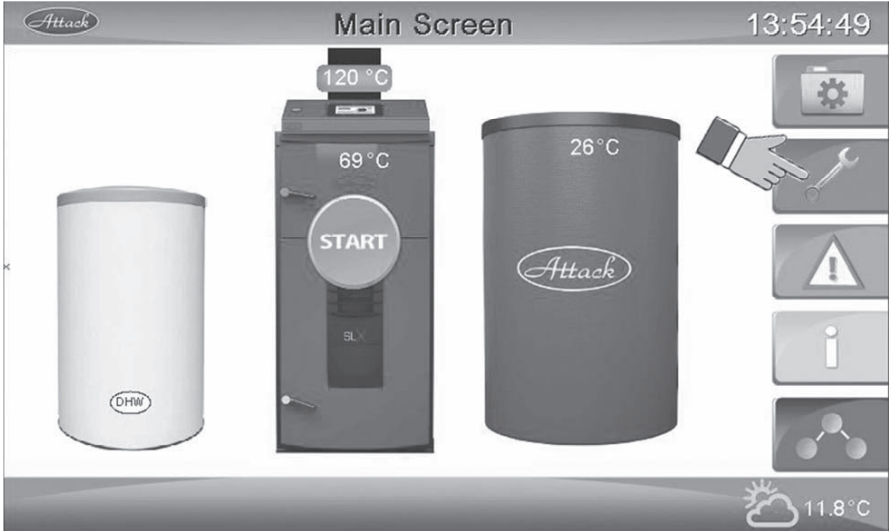

Pic. 19 Entry into General settings



Pic. 20 Entry into TESTMODE

Automatically you get into TESTMENU where you can test devices.

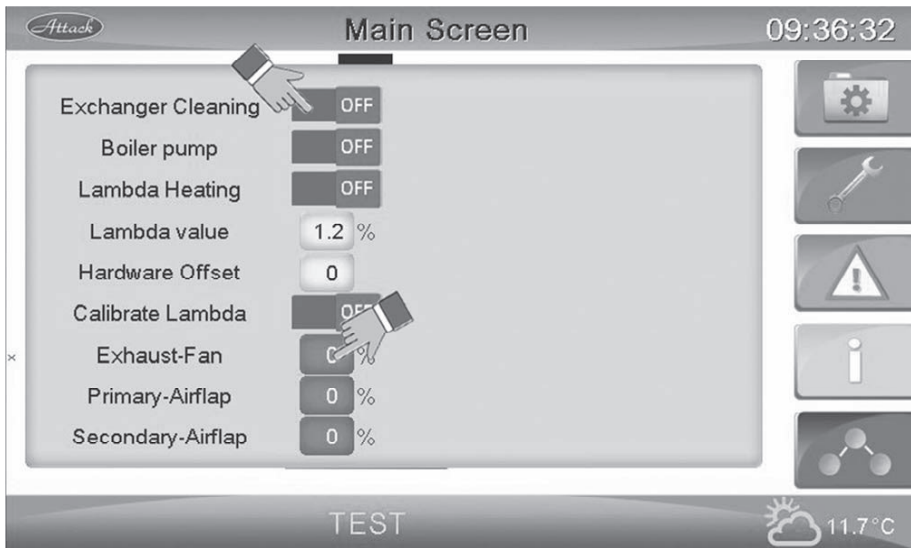

Pic. 21 *Displaying of test menu*

By calibration of Lambda probe it is needed to activate firstly Heating of Lambda probe, wait a minute and then turn on calibration of Lambda probe.



NOTICE! If Lambda probe reaches value 21% during the heating it is not needed to calibrate it. Before calibration of the Lambda Probe it is needed to turn on the Heating of the Lambda probe.

After calibration the values of Harver's shift will be adjusted.

For starting testing of any device click on button or number next to it (Pic. 21).

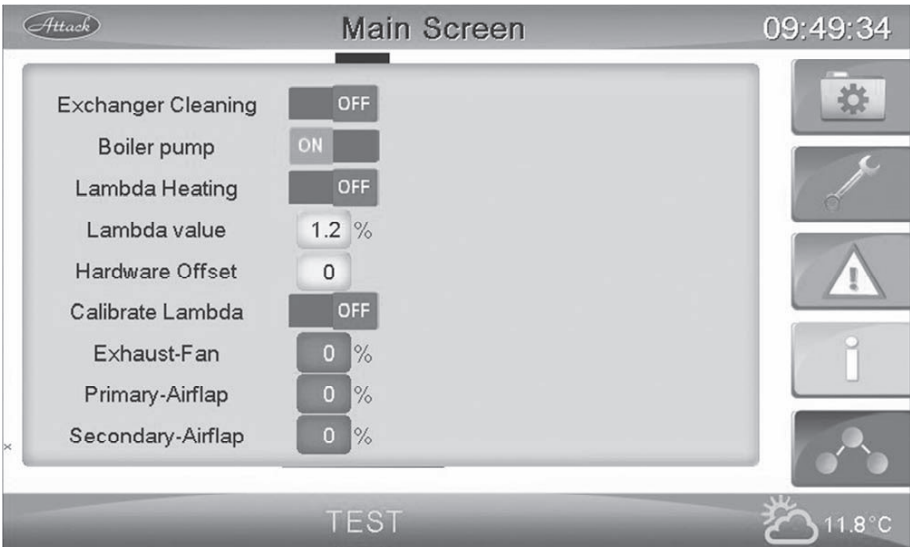

Pic. 22 Testing activation of devices unable to be changed (modulated)

For testing of changeable (able to be modulated) devices click on numbers next to the symbol %. There will be displayed dial plate where you can set % for how much % the device should work.



Pic. 23 Testing activation of devices unable to be changed (modulated)



CAUTION! After the end of testing of any devices it is always needed to turn off these devices.

After finishing of the testing come out from test mode with the button OFF (Pic. 24).



Pic. 24 Finishing of the boiler's test mode

6.4.4 STARTING UP THE REGULATOR

WOOD IGNITION AND OPERATION

The way of wood loading in the chamber is described in the chapter 6.2 We start the boiler by pushing the button START (Pic. 25)

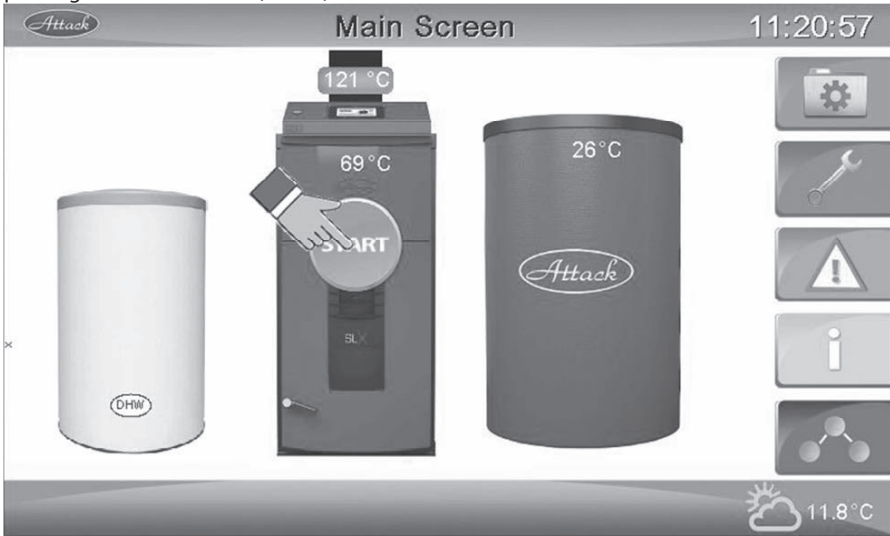

Pic. 25 Boiler start on

1. After the boiler's starting the exhaust fan starts to work and it is possible to ignite the wood. You can check the current boiler status in information menu. (Pic. 26).

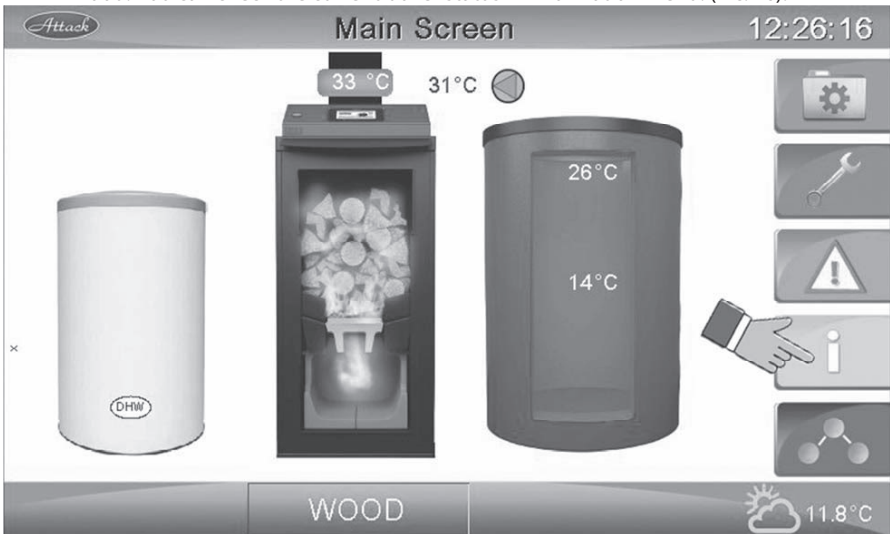

Pic. 26 Input into information menu

2. On display there will be displayed information Ignition (Pic. 27)

The screenshot shows a control panel interface titled 'Status information' with a timestamp of 12:32:50. The main display area contains a table with two columns: 'Actual' and 'Setpoint'. The parameters listed are Boiler temperature, Oxygen, Exhaust temperature, Exhaust-Fan, Wood Primary-Airflap, Wood Secondary-Airflap, and Exchanger cleaning. Below the table, there are four buttons: 'Boiler-State', 'Starting', 'Wood', and 'Ignition'. The 'Ignition' button is highlighted. On the right side, there is a vertical stack of icons: a gear, a wrench, a warning triangle, an information 'i' icon, and a network diagram. At the bottom right, there is a weather icon showing a sun behind a cloud and a temperature of 11.8°C.

	Actual	Setpoint
Boiler temperature	31 °C	80.0 °C
Oxygen	1.2 %	6.5 %
Exhaust temperature	33 °C	160.0 °C
Exhaust-Fan	100 %	255
Wood Primary-Airflap	100 %	1000
Wood Secondary-Airflap	2 %	216
Exchanger cleaning	00:59:20	

Boiler-State Starting Wood Ignition

11.8°C

Pic. 27 Ignition phase

3. If the flue gas temperature rises after ignition, the boiler comes into the phase Pre – Heating (Pic. 28).



CAUTION:

Pre – Heating phase – phase coming when the flue gas temperature rises during the set time in parameters. If the flue gas temperature rises during another time set in parameters the boiler crosses into Control phase.

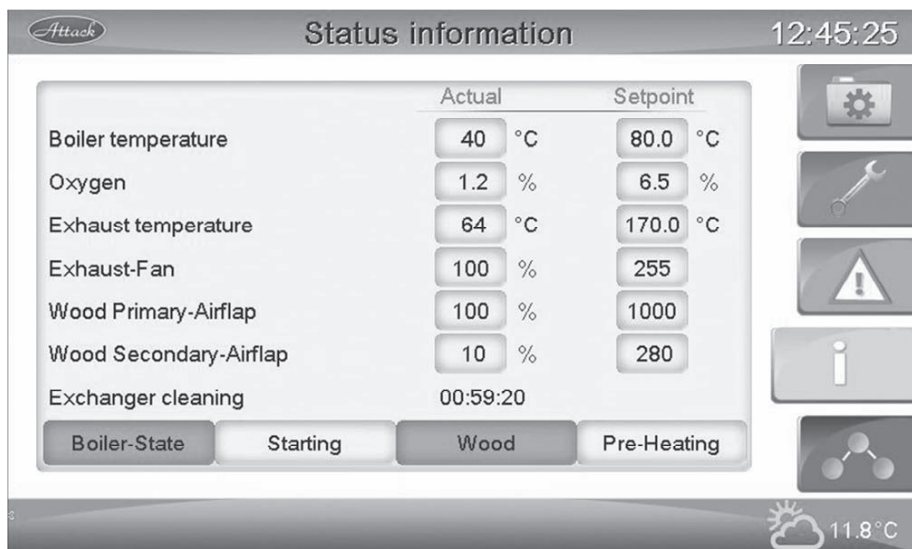

Pic. 28 Pre – Heating phase

4. If the rising of flue gas temperature continues the boiler will cross into the phase of Regulation (Pic. 29).

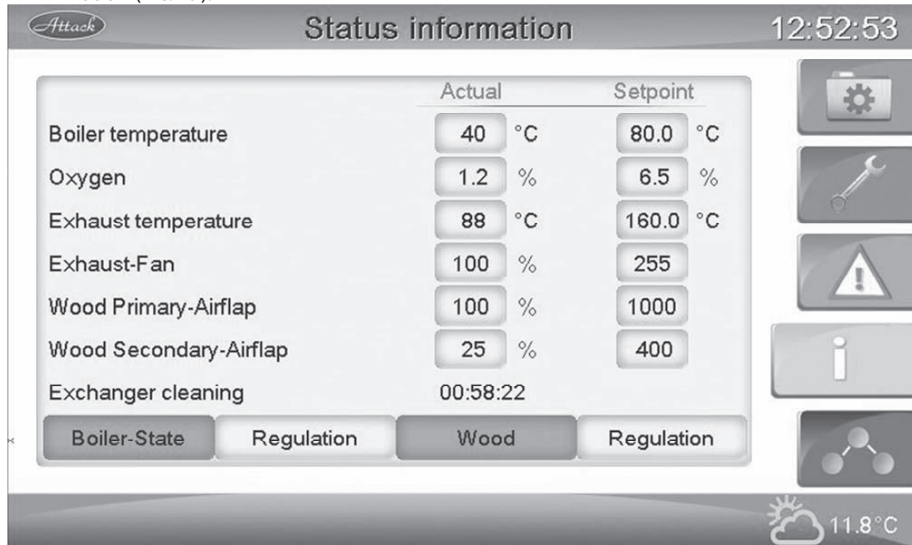

Pic. 29 Control phase

5. If the boiler exceeds own set boiler temperature for „ temperature of boiler temperature exceeding“, switches to the „keeping ember“ mode. In this moment is boiler switched off, lowers its own output and waits until the boiler temperature drops. Do not open the door of feeding chamber in this case (figure 30).

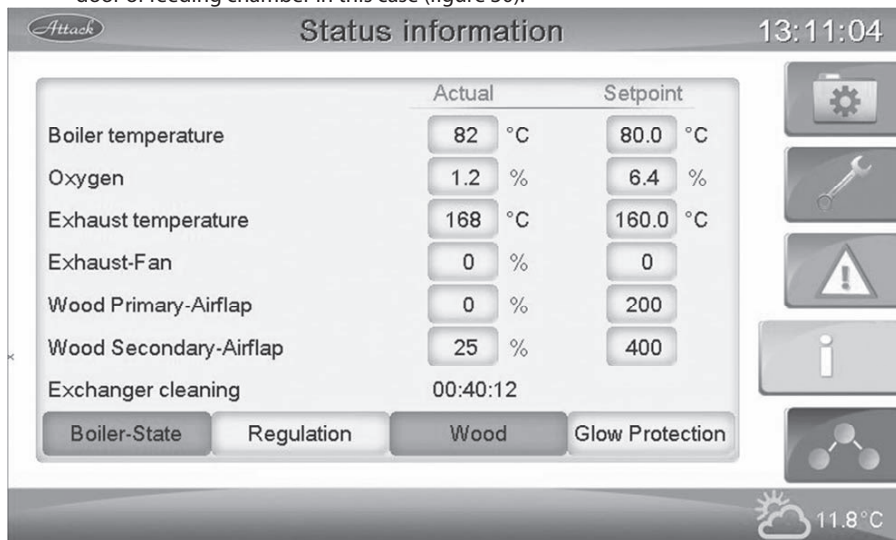

Pic. 30 Glow (Ember) Protection phase

6. If you want to stop burning, click on button WOOD on Main Screen of the boiler (Pic. 31).

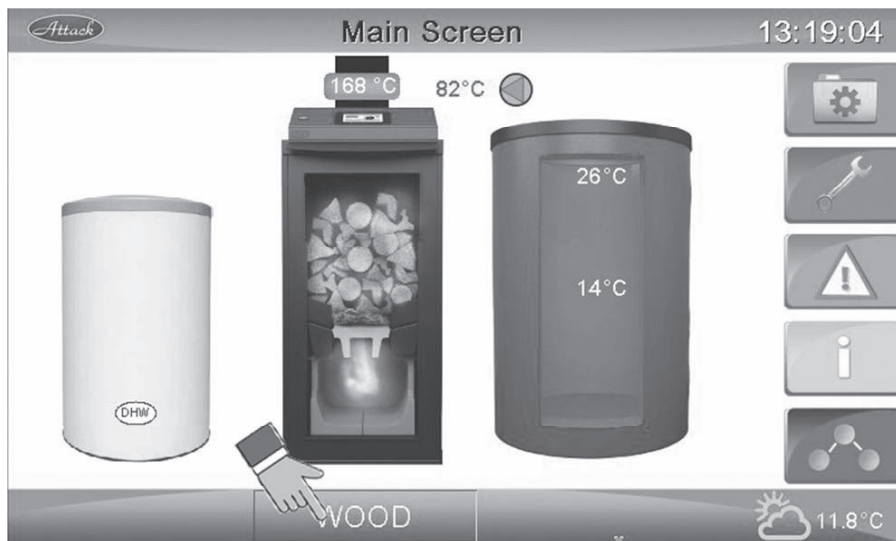

Pic. 31 Boiler stopping

7. After stopping burning the warning picture is shown. This picture informs, that burning has already started and it is not safe to stop it. Use it only in the most necessary cases (pic. 32)



Pic. 32 CAUTION picture

8. After burning out the fuel gas fan turns off and the primary – airflap closes.



Pic. 33 Display after burning out

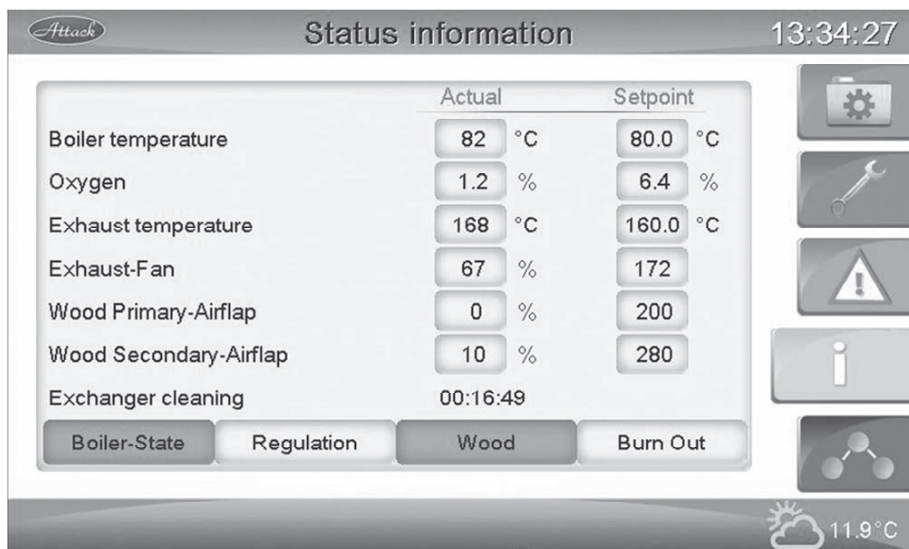

Pic. 34 Burn Out phase

WOOD LOADING

LAMBDA Touch regulator is equipped with terminal switch of the upper door, that is why, fan always runs during the door opening at full output. This allows exhausting the flue gas to the chimney with the highest possible efficiency. Fan starting up is also functioning, when is the boiler out of operation mode – e.g. during the boiler cleaning.

6.5 DISPLAYING THE INFORMATION

It is possible to read various information about boiler state and state of the particular devices (fans, flaps etc.) on the touch screen during the operation and also out of the operation. Enter to the information menu by pushing the „i“ button (pic. 35).

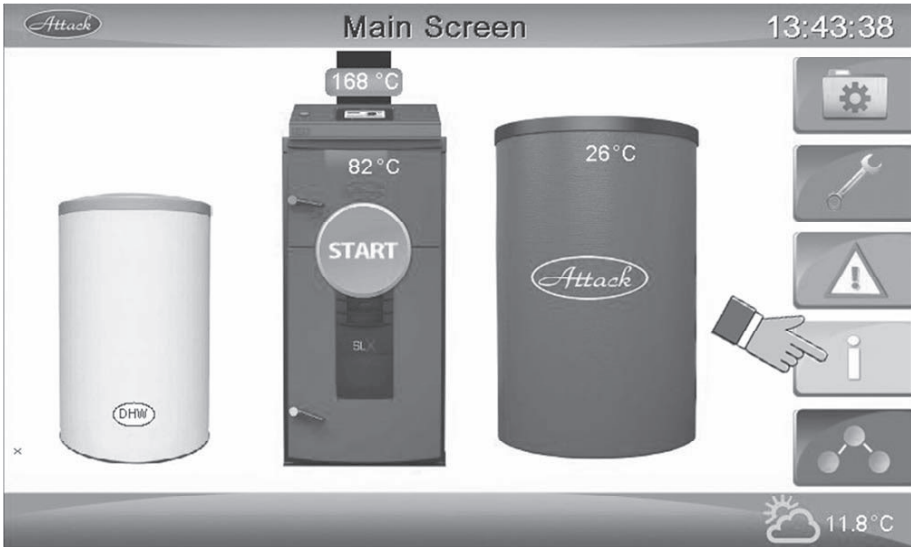

Pic. 35 Click for displaying information

Information status (Pic. 36) represents current information about the boiler's status, its temperature, exhaust temperature, the power of exhaust – fan, the opening of primary and secondary airflap, current value of oxygen, activity of heat pump and opening and closing of upper door.

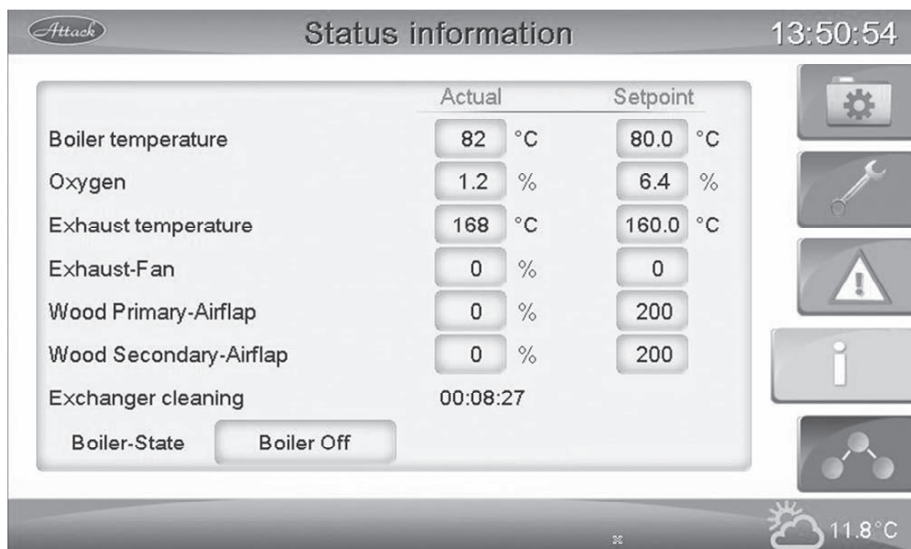

Pic. 36 *Displaying of information*

6.5.1 SETTING THE PARAMETERS

The boiler ATTACK SLX LAMBDA Touch enables parameters setting in two levels. First level is the basic level designed for end – customer and enables to set the most basic parameters of the boiler, i.e. boiler and flue gas temperature, the temperature of starting of heat pump etc.

Settings level user parameters we display by click on button of parameters (Pic. 37).



Pic. 37 *Clicking on displaying of parameters*

There are displayed basic parameters which can be set by end – customer (Pic. 38).

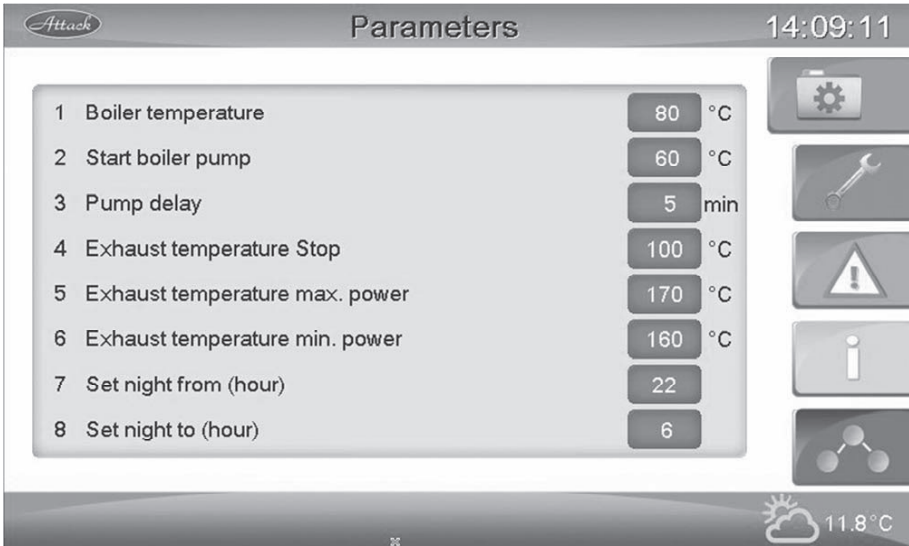

Pic. 38 Setting of basic parameters for end – customer

Description of parameters:

Boiler temperature – set temperature which should be reached

Start boiler pump – the temperature when the pump is switched on

Pump delay – the time of pump delay (run down) when the temperature returns below the pump on safety temperature

Exhaust temperature Stop – when the flue gas temperature turns down below this temperature there is written the lack of fuel

Exhaust temperature max. power – the flue gas temperature then the boiler reaches its nominal output. This temperature depends to boiler's output and the temperature's values are :

Boiler type – Flue gas temperature	Boiler type – Flue gas temperature
20SLX – 165 °C	40SLX – 160 °C
25SLX – 170 °C	45SLX – 165 °C
30SLX – 175 °C	50SLX – 175 °C
35SLX – 180 °C	55SLX – 185 °C

Exhaust temperature min. power – minimum flue gas temperature which is automatically set by the boiler in case it must work at reduced power. For boiler's regulation of its output the recommended minimum temperature is 160 °C. The minimum flue gas temperature must be set over 150 °C to prevent flue gas condensation in the chimney.

Set night from (hour) – if the heating circuit is connected we determine the hour of night start when the heating circuit can reduce the temperature

Set night to (hour) – if the heating circuit control is connected we determine the hour of night termination

6.5.2 GENERAL SETTINGS

In the boiler ATTACK SLX it is possible to set General settings.
For displaying General settings click on service key.

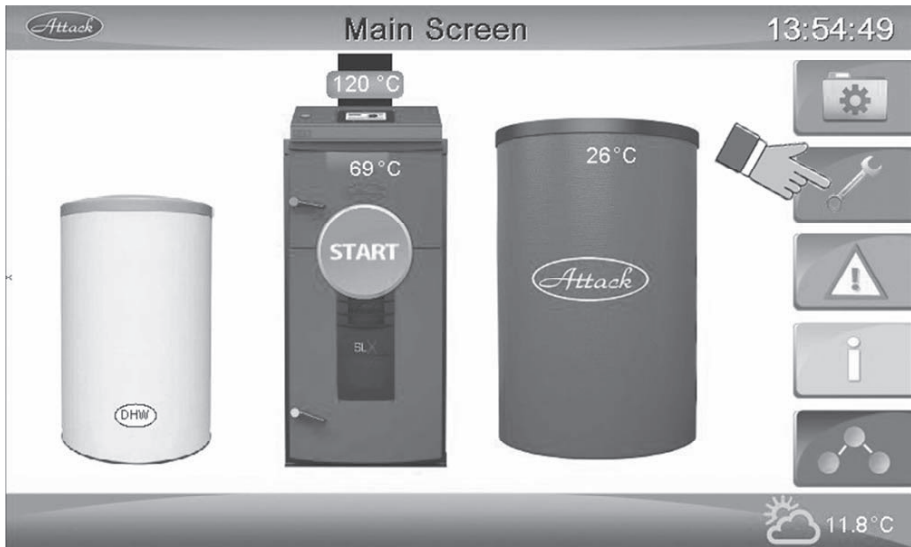

Pic. 39 Click for displaying General settings



Pic. 40 General settings

1 – language selection, 2 – internet connection, 3 – saving and loading settings, return to factory settings, 4 – service settings, 5 – timer settings (it is worthy after connection of external moduls), 6 – TEST MODE

Set the time / date – it is possible to set the exact time and date. If the boiler will disconnect. If the boiler is disconnected from the power supply or the electrical supply of the boiler falls out for some reason, it can keep the time and date for about 3 days.

Screensaver – time when the screen saver will be activated

Program version – displays information about the current boiler program version

PLC Serial no. – electronic's serial number

Sound alerts (failures, warnings, upper doors) – enable error tones for faults, boiler warnings and opened boiler's door.

6.5.3 CONNECTION TO THE INTERNET

It is possible to connect the boiler with LAN connection to the internet and control it from remote device. Control is accessible in local network, but also from internet. It is necessary to have international IP address from internet provider to get access from internet.

1. Connect Ethernet cable to the connector from the back side next to feed cable.
2. Click on General Settings (Pic. 41)

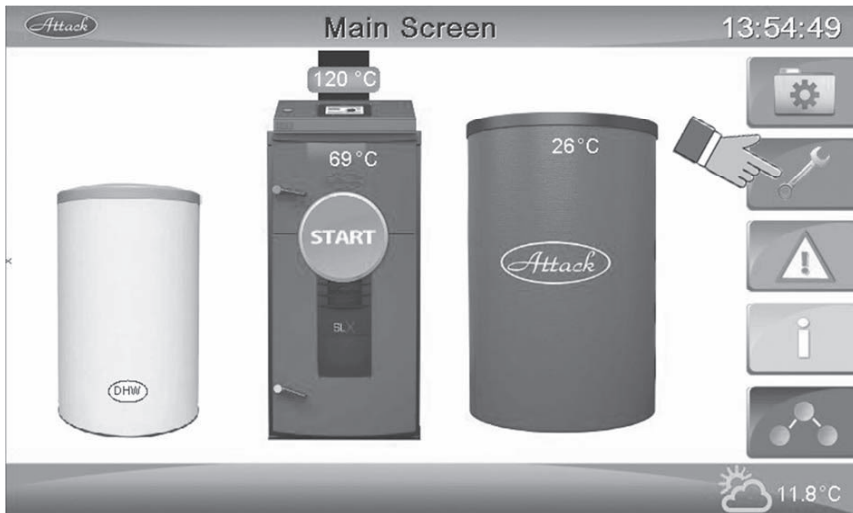

Pic. 41 Entry to General settings

3. Click on button Internet connection (Pic. 42)



Pic. 42 Click on button Internet connection

4. We set the correct parameters of internet connection via the button dynamic allocation IP where your router assigns IP address to your boiler (if you have static IP address enter it manually) (Pic. 43)

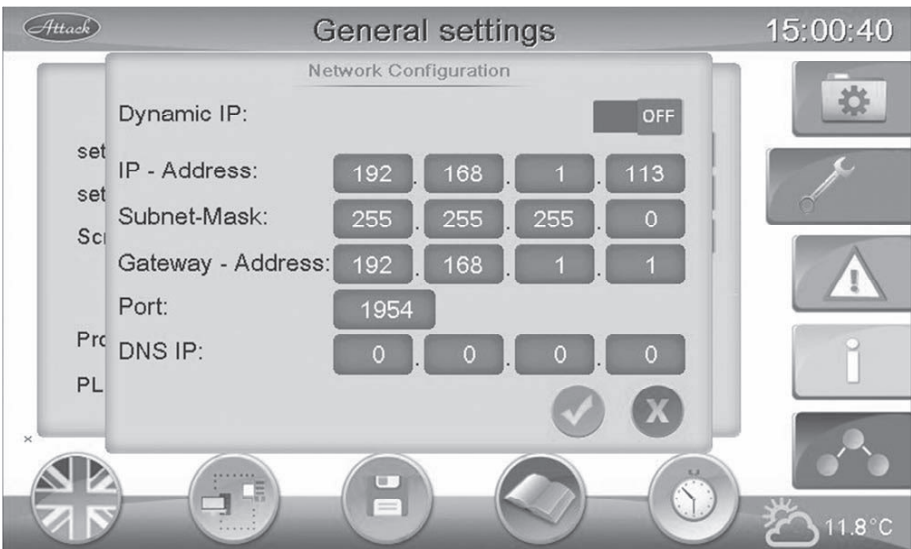

Pic. 43 Setting of IP address for communication via LAN or internet

It is possible to control and get access with smartphone, by use of applications:

Android:	Desktop 169
iOS:	Mocha VNC Lite
Destination port:	5900
Pasword:	attack

**The boiler can also be controlled and made available via a computer via the program:
VNC Viewer (e.g. UltraVNC)**

**NOTICE!**

If you have an automatic IP address allocation via DHCP in the router, the IP address may change.

6.5.4 SOFTWARE UPDATE

The software applied in the electronics can be updated. You can request the latest software directly from ATTACK. To do this, do the following:

- you will get the new software in the zip file, there is another folder
- copy all files from folder on blank USB of max. 2 GB
- switch off the boiler by a switch
- insert the USB key with the software into the boiler display
- turn on the boiler with the main switch and wait
- the ATTACK logo appears on the screen, then the white screen with white commands
- at the end of installation there will be written "Please remove USB media (Terminal will restart after)" (Pic. 44)
- new software will be installed after the boiler's restart



CAUTION! Never install new software while the boiler is operating.

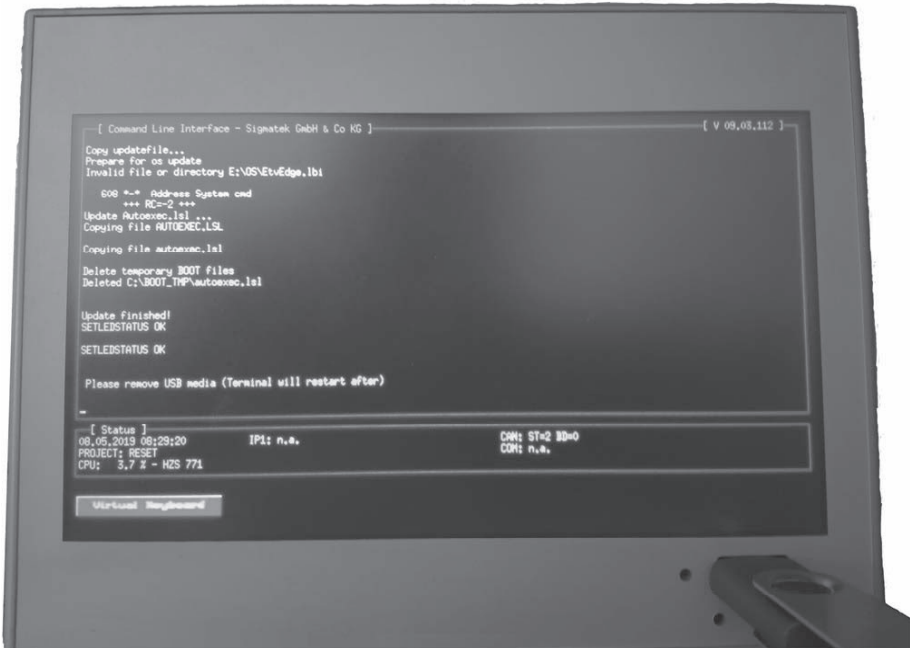

Pic. 44 New Software Update

6.5.5 FACTORY SETTINGS

If the boiler has failed and the boiler is in a state where it is not possible to remove the fault or to select the desired boiler mode, it is necessary to restart the boiler. We enter into General settings and click on floppy disk of the boiler. The boiler will reset into factory settings. The condition for reset is USB key in display.

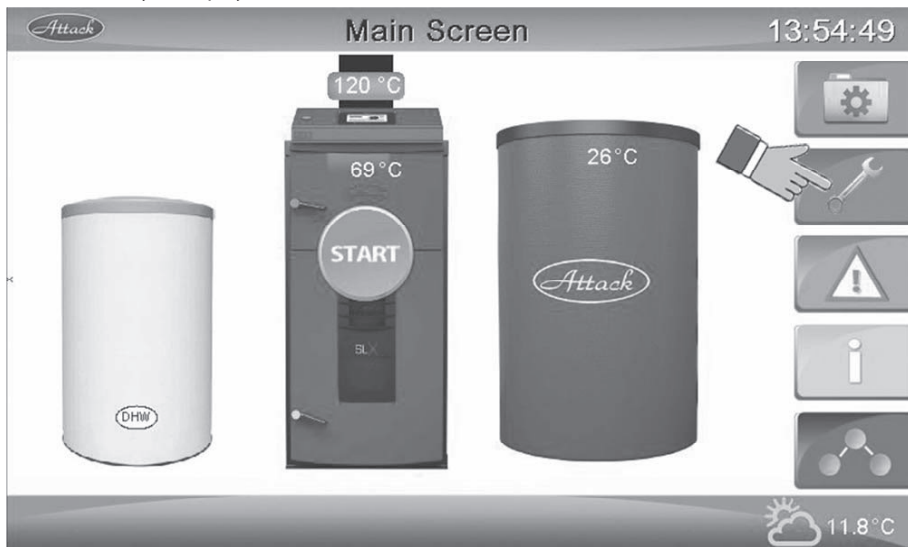

Pic. 45 Click to display general settings



Pic. 46 Click to floppy disk

7 RISK ANALYSIS

Boiler is not filled with water

If the customer heat up in the boiler, which has no water, it comes to the dangerous situations. Flame created in the boiler starts to heat up the boiler body, which is not cooled and heats it to the temperature, which achieves temperature of the combustion chamber. Boiler body starts to heat the insulation, which surrounds the boiler and gradually degrades it by heat. Insulation gets black and starts to smoke. If its temperature achieves 1 000 °C, it might lead to its burning too. After the heat degradation of insulations, comes to the degradation of conductors, electric power supply to the boiler, electric power supply for fan, pump etc. When some of these conductors get completely melted, it comes to the contact with boiler framework, what leads to the short circuit. Short circuit might cause burning of the plastic parts in the inside of the boiler. If the temperature is high enough, it leads to the burning of conductors and plastic parts of the boiler control. Afterwards, flame might be transferred from the boiler to the area of boiler room. If it was heated up in the boiler already, boiler is warmed up and then you realize, that the water is missing, do not fill the water for cooling to the boiler by no means. Filling the cold water to the incandescent boiler body would lead to immediate formation of high – pressure steams, what might lead to the boiler explosion. In this situation, is better to take out the wood out of the boiler with use of protective gloves, fire poker and ashtray. Extent of these risk situations depends on the amount of fed fuel. More fuel means higher risk.

Safety valve is not functioning

In case, that safety valve of heating system is not functioning or incorrectly installed (e.g. in the flow connection and it comes to the exceeding of max. permitted pressure in the circuit (for various reasons like incorrectly dimensioned expansion tank, too high inlet pressure, too high temperature in the boiler), it might lead to the dangerous situations. After exceeding max. bearable pressure in the boiler, it comes to its mechanical destruction and usually in the presence of explosion effect. This effect might lead to the loss of property or life. For that reason is very important to install safety valve correctly (riser pipe of the system) and to check it regularly.

Blocked valve at cooling circuit /insufficient pressure of cooling water

Cooling circuit is an important part of the gasifying boiler. It serves for draining excessive warmth from the boiler to the waste, to prevent boiler overheating and further dangerous situations. If is the functionality of this cooling circuit limited or circuit is not functioning and it comes to the boiler overheating, it leads to the excessive pressure rise in the boiler and risks described above. Circuit functionality is ensured by thermostatic valve and sufficient pressure of the cooling water (min. 2 bars). For that reason is very important to check the functionality of the cooling circuit regularly.

Incorrectly installed chimney

Chimney is an important part of the correctly working heating source. Chimney has to be correctly dimensioned and fixed to the construction of the building or be its part. If the chimney would not be fixed enough and it would come to the off – axis movement of the chimney parts, flue gas, which comes out of the boiler would leak to the boiler room or to the space, where the chimney goes through. This flue leakage is very dangerous, it might cause suffering from mild poisoning by flue gas and also fire. Pay attention to correct and safe performance of the chimney installation.

In case, that:

- Frequency of fuel feeding to the boiler is too low, it might lead to the overall lowering of the boiler output. Frequency of fuel feeding to the boiler should be every 4–8 hrs, depending on the boiler type
- It comes to the closing of air inlet to the boiler, it might lead to the insufficiency of oxygen for combusting and explosive reactions of wood gas in the boiler nozzle. Always pay attention to sufficient inlet of fresh air for correct function of the boiler.
- It comes to the electric energy supply cut in the boiler, which works at full output, all electrical devices of the boiler will be non – functional. Boiler cooling will be ensured by integrated cooling circuit connected to the common non – portable cold water with pressure of min. 2 bars and temperature of max. 20 °C. Electricity failure can not influence supply of cold non – portable water for boiler cooling. Starting up of the cooling with integrated cooling circuit works on the basis of thermostatic valve.
- In the combustion chamber is unstable pressure, it might lead to instable combustion, efficiency lowering and emission rise. In case of this effect, please, check correct tightness of all doors, cleaning holes, inspectional holes, value of the chimney draught or if the boiler is cleaned enough.
- Some of the doors or cleaning holes are not closed enough, it comes to the lowering of boiler efficiency, incorrect setting of ratio of primary and secondary air, flame loss, or to insufficient flue gas drain out of the boiler. For correct function of the boiler, please ensure, that all openable parts of the boiler are correctly tightened.
- Feeding door of the feeding chamber is opened too long or it is left opened , it might lead to the flue gas leakage from the boiler to the boiler room. Opened feeding door also influences boiler output and burning stability. Because of that, do not prolong the feeding process and make it as short as possible.
- There is not enough fuel in the feeding chamber, it leads to the drop of flue gas temperature and because of that is boiler put out of operation. It is necessary to load the fuel in regular 3 – hours intervals, for nominal output of the boiler.
- During the boiler ignition does not come to the creation of sufficient heat, it might lead to the early burn out of the flame and because of that is boiler put out of operation. Always pay attention to sufficient heat up of the wood in the boiler during ignition, to create stable flame.
- In the boiler room is installed another ventilating device, it might lead to the insufficiency of combustion air or flue gas leakage.

Maximal height of the wood loading to the boiler is not restricted, load the wood to the boiler always at full. It is necessary to load the wood, to prevent its sticking in the chamber and also allow its free movement downwards during its gradual combustion. Frequency of wood loading by nominal output is 5–7 hours for hard wood and 3–5 hours for soft wood.

In case of failure or incorrect boiler operation is necessary to measure:

- flue gas temperature,
- boiler temperature – temperature of heating water,
- wood moisture
- volume of oxygen in the flue gas by flue gas analyser
- chimney draught

Ensuring sufficient inlet of combustion air:

For correct boiler functioning is necessary to ensure sufficient amount of combustion air by opening windows of the boiler room or by inlet piping.

It is recommended

Measure boiler emissions after first start up of the boiler.

Fuel storing

It is necessary to pay attention to several instructions by storing the fuel. Wood should be stored in dry and ventilated place to prevent its moisture rise. Wood has to be stored far enough from boiler to prevent its ignition. It is necessary to store the wood to prevent its falling down.

8 BOILER MAINTENANCE

It is necessary to maintain the boiler during its life – time to make it work properly. Frequency of maintenance depends on the utilization rate of the boiler during the operation.

Maintenance of heating system together with the boiler

At least once every 14 days, check and if it is needed fill up with water in the heating system. If the boiler is out of order during the winter, there is a risk of water freezing in the system and therefore drain the water from the system or fill the antifreeze. Otherwise, drain the water only in the most necessary case and preferably for the shortest possible time. After the heating period, clean the boiler properly, replace the damaged parts. Remove the fan twice a year and clean the impeller and fan air chamber.

Hinges tightening and replacing sealing cord of door.

During the common operation, door cords lose their flexibility and it leads to the loss of door tightness. We can change the door hinge position multiple times (in direction to the inside of the boiler – to push more the door cord) to ensure maintenance and tightness increasing. When cord lose its flexibility completely, or when the hinges cannot be further moved in direction to the boiler, there is a need of replacement. Perform replacement by dismantling the old one with screwdriver and clean the groove where the cord laid. Take new sealing cord and place the beginning on the horizontal grooves. Push it in the groove at the door circumference by hand or by tapping with hammer. Loosen hinges and find correct position of door to boiler body.

Replacing the nozzle body

Nozzle body is placed in the boiler body on the nozzle holder. In the bottom part is nozzle body sealed with boiler sealant and in the upper part with sealing cord at its circumference. When replacing the nozzle, remove the sealing cord from the nozzle groove by a screw driver. Take the nozzle body out and clean the holder properly from tar and old sealant. Put the new refractory sealant on the cleaned surface. Put the nozzle on the holder – shorter wall has to be in the rear part of the boiler up to the end. There should be the same space on the both sides of the nozzle. Take the new set of sealing cords for the nozzle and press it lightly into the gap just around the nozzle

8.1 BOILER CLEANING

It is necessary to clean the boiler regularly to ensure correct operation and required comfort and life – time.



NOTICE: Always perform boiler cleaning regularly and thoroughly, otherwise it may leads to the life – time decrease or incorrect combustion! Warranty is not valid if the boiler is not cleaned regularly and sufficiently.

It is necessary to perform cleaning regularly and thoroughly every 3 – 5 days, because sedimentation, condensates and tar in the combustion chamber significantly lower life – time, output and efficiency of the boiler. If there is a higher amount of ash, fuel does not have sufficient space for burning and it might lead to the damage of holder of ceramic nozzle and because of that, to the damage of whole boiler. Perform boiler cleaning by starting the fan at first, opening feeding door and brushing all dirt down to the lower part. Leave long pieces of unburned fuel in the loading chamber. Move several times with the lever of exchanger cleaning, on the left side of the boiler. Open the lower cleaning hole and take the ash and soots out. Open lower door and clean lower part of dirt. Cleaning interval depends on fuel quality (moisture) and heating intensity, chimney draught and other factors. We recommend to clean the boiler once a week. Do not pull the fireproof parts out of the boiler during cleaning.



NOTICE: Regular and proper cleaning is important for ensuring permanent output and life – time of the boiler. Boiler might get damaged if it is not cleaned properly and warranty is not valid.

Regularity of cleaning of particular boiler parts is stated in the table below:

Cleaning*	Daily	Weekly	Annually
Taking out the ash	1 ×		
Space around the ashtray		1 ×	
Space below the tubular exchanger		1 ×	
Lever of turbulators (not for LAMBDA version)	5–6 ×		
Canal of flue gas exhaust			1 x
Fan space			1 ×
Fan Wheel			1 ×

* Minimal recommended intervals of cleaning. They might be performed more frequently, according to the operation intensity

8.2 INSTALLATION AND REPLACING OF FIREPROOF PARTS

If you want to exchange or check the fireproof parts, do as follows:

1. Start up the fan
2. Clean the boiler of burning leftovers, ash, dust and tars
3. Take out the vitreous sealing cords as shown in the picture

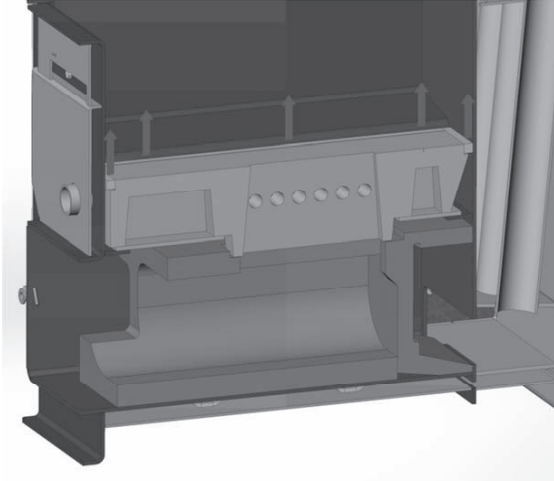

4. Take out the nozzle
5. After removing the nozzle, it is possible to take out the ashtray (see picture)

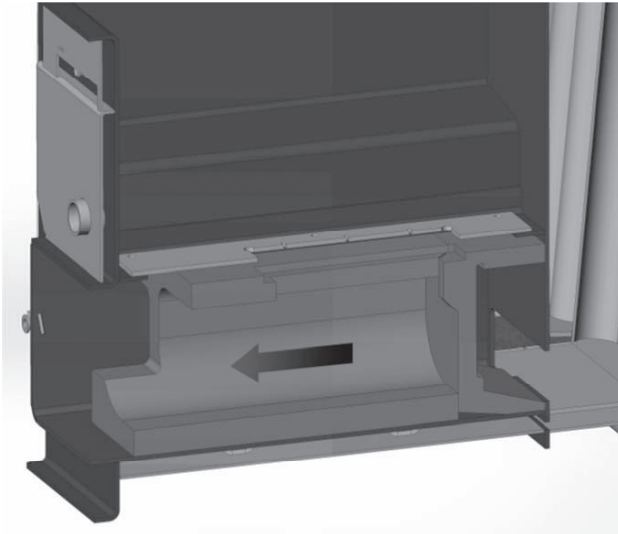

6. Take out the rear fireproof part (see picture)

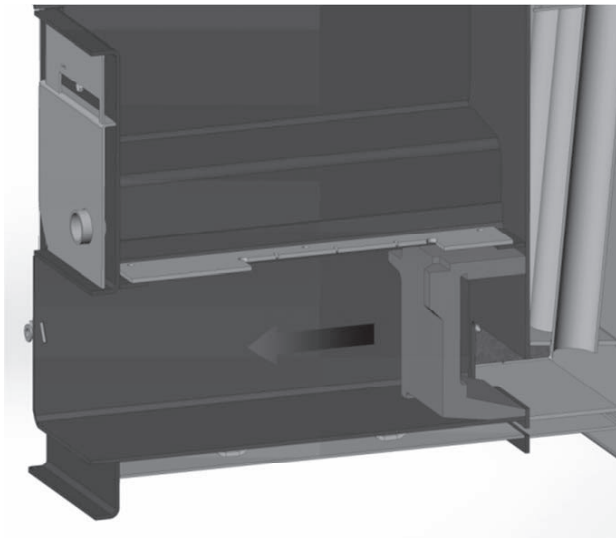

7. Turn off the fan

Perform installation of fireproof parts in reversed procedure, as described above.

9 TRANSPORT, MANIPULATION AND STORING

Product is placed on the pallet, to which is attached by the technological screws. It is packed in the boxboard, lashed with lashing tape and wrapped with plastic film. Transport, manipulation and storing of wrapped product is allowed only on this pallet.

There are hanging loops accessible after removing the upper covering, for manipulation with the boiler by crane.

Manipulation with product might be performed only by the authorized person.

9.1 INSTRUCTIONS TO PRODUCT DISPOSAL AFTER TERMINATION OF ITS LIFE – TIME

Ensure product (boiler) disposal by means of some Waste collection point , or use controlled disposal site, maintained by appropriate municipal authority.

9.2 WRAPPING DISPOSAL

Dispose wrapping by means of some Waste collection point or use disposal site.

9.3 ACCESSORIES

ATTACK boiler is supplied functionally tested, wrapped, placed on the wood pallet.

Delivery includes following accessories:

- Fire poker
- User manual
- Warranty list
- List of contracting service organisations

It is possible to buy to the boiler SLX:

- Accumulation tank
- Set of sensors to accumulation tank (in case you have LAMBDA TOUCH)
- Set of modules for controlling of heating (HZS 532, HZS 533) (in case you have LAMBDA TOUCH)
- Automatic boiler
- Domestic Hot Water Storage Tank (D.H.W.)

10 AUTOMATIC BOILER CONTROL

The boiler enables to control switching on of the automatic boiler after burning all fuel out without the installation of additional modules. The condition of automatic boiler start function is the temperature sensors in the accumulation tank are correctly installed.

Automatic boiler is being connected to the connector X13 on boiler's main board.

To activate the automatic boiler function you have to enter into Heating Circuit (Pic. 47).



Pic. 47 Click for displaying of Heating circuit

You will see a complete diagram of the entire heating circuit (Pic. 48). After the clicking on arrows you can see a complete external diagram of the heating circuit which can be managed by boiler after installing of up to 6 external modules and elements.

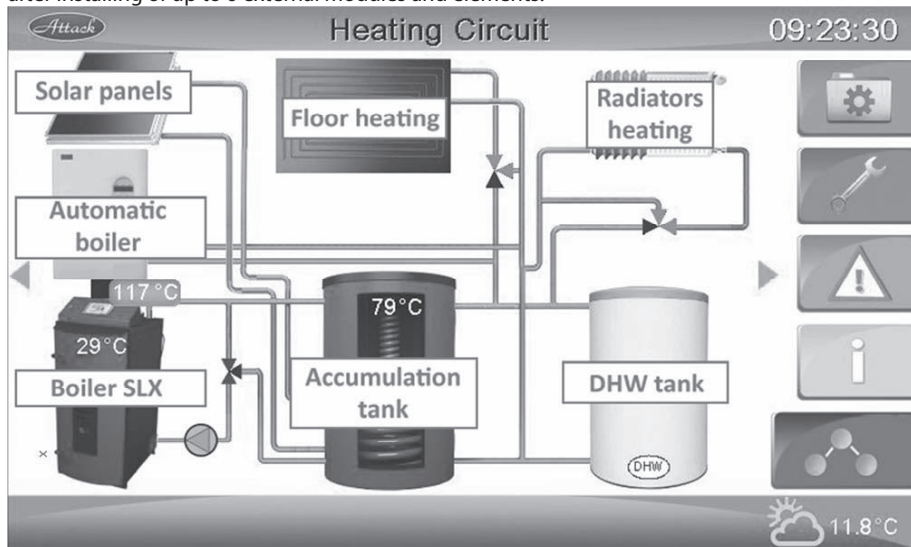

Pic. 48 Basic description of heating circuit

To enable the automatic boiler start function, click the boiler symbol (Pic. 49 where you can see the parameter table (Pic. 50)).

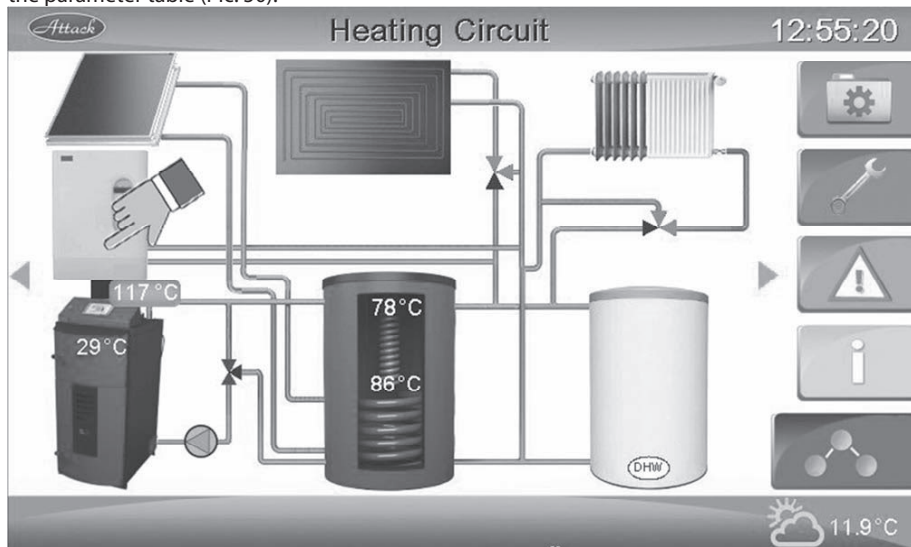

Pic. 49 Click for activation of automatic boiler's function

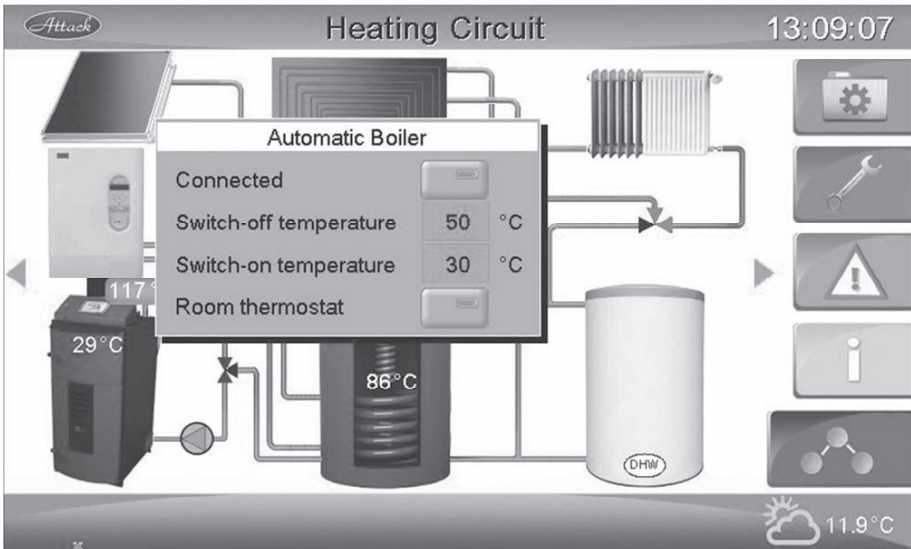

Pic. 50 Automatic boiler's parameters

Connected – when this function is activated, the automatic boiler switches to standby mode

Switch – off temperature – if the temperature of the upper accumulation tank sensor reaches this setpoint, the automatic boiler switches off.

Switch – on temperature – if the temperature of the upper sensor in the accumulation tank falls below this value, the automatic boiler is switched on.

Room thermostat – this function must always be activated if you want the boiler to be controlled according to the storage tank temperatures. Room thermostat can be connected to the boiler.

11 POSSIBLE FAILURES AND THE WAY OF ITS REMOVAL

Failure	Cause	Solution
<i>Display does not light</i>	No voltage in mains Incorrectly plugged in the socket Damaged mains switch Damaged input conductor	Check Check Replace Replace
Boiler does not achieve required parameters	Lack of water in the system High pump output Boiler output is not sufficiently dimensioned for given system Poor – quality fuel Low chimney draught High chimney draught Long heat up Insufficiently cleaned boiler Clogged air inlet to combustion chamber	Refill Set output Matter of project Combust dry and chopped wood New chimney, unsuitable connection Install restriction flap into the flue Use thinner wood by ignition Clean Clean
<i>Door does not seal</i>	Damaged vitreous cord Nozzle gets clogged Low chimney draught	Replace, set door hinges Do not combust small wood and bark Damaged chimney
<i>Fan does not rotate or is noisy</i>	By use of non – returnable safety thermostat comes to the disconnection during overheating Clogged wheel Wrong condensator Wrong engine Wrong contact in socket of input conductor from engine	Push the button of thermostat Clean the fan Replace Replace Check

12 CHARACTERISTIC OF TEMPERATURE SENSORS

Characteristic according to appropriate temperature sensors is mentioned below:

1. sensor of the boiler temperature scanned by the PROFI PID regulator
2. sensor of the flue gas temperature scanned by the PROFI PID regulator, boiler and flue gas temperature scanned by the Lamba Touch regulator

It is possible to easily measure by electric meter, if the sensor is not damaged or has correct characteristic, according to the sensor resistance and temperature. Sensor is probably damaged, if it shows values substantially different from characteristic mentioned above or if it shows nothing at all. In this case, is necessary to replace the sensor.

Temperature [°C]	Resistance [Ω]	
	1 KTY81 – 210	2 Pt 1000
-20	1 367	921
-10	1 495	960
0	1 630	1 000
10	1 772	1 039
20	1 922	1 077
30	2 080	1 116
40	2 245	1 155
50	2 417	1 193
60	2 597	1 232
70	2 785	1 270
80	2 980	1 308
90	3 182	1 347
100	3 392	1 385
110	3 607	1 422
120	3 817	1 460
130	4 008	1 498
140	4 166	1 535
150	4 280	1 573
160		1 610
170		1 647
180		1 684
190		1 721
200		1 758
210		1 795
220		1 831
230		1 868
240		1 904
250		1 940

13 SERVICE PARAMETERS SETTINGS

The service parameters setting level is only available after entering the access code. For displaying service parameters you have to enter to General settings (Pic. 51).



CAUTION! Do not modify the boiler service parameters unless you have the privilege to do so. Incorrect parameter setting may result in incorrect boiler operation, too low boiler temperature and tar formation or too high boiler temperature. In both cases there is a risk of fire.

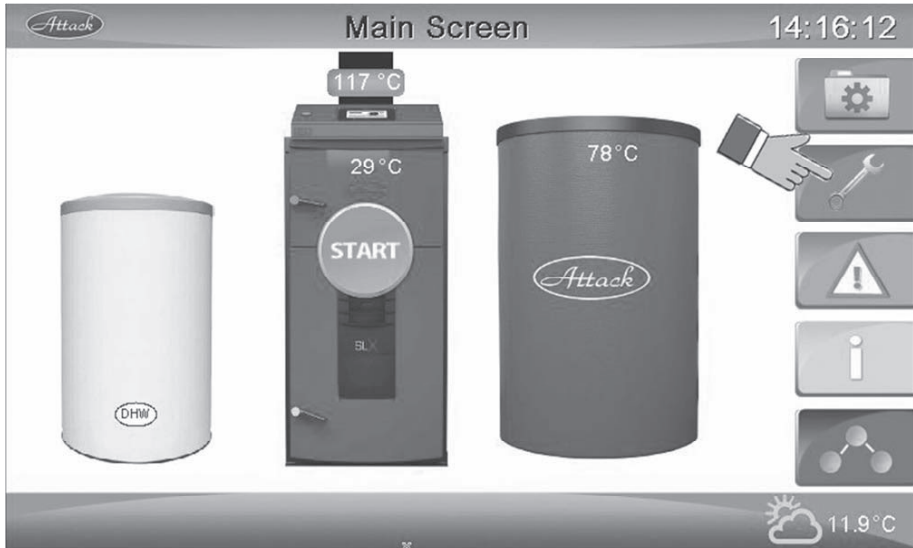

Pic. 51 Click for the entry for General Settings

Then click on picture of Service Settings (Pic. 52).



Pic. 52 Entry into Service Settings

Clicking on Picture of Service Settings there will be displayed the keypad where we will enter the service code "7319".



Pic. 53 Access to advanced parameters

After entering the service technician's access code, the advanced boiler parameters are made available. Automatically you get into the menu of Service Settings.

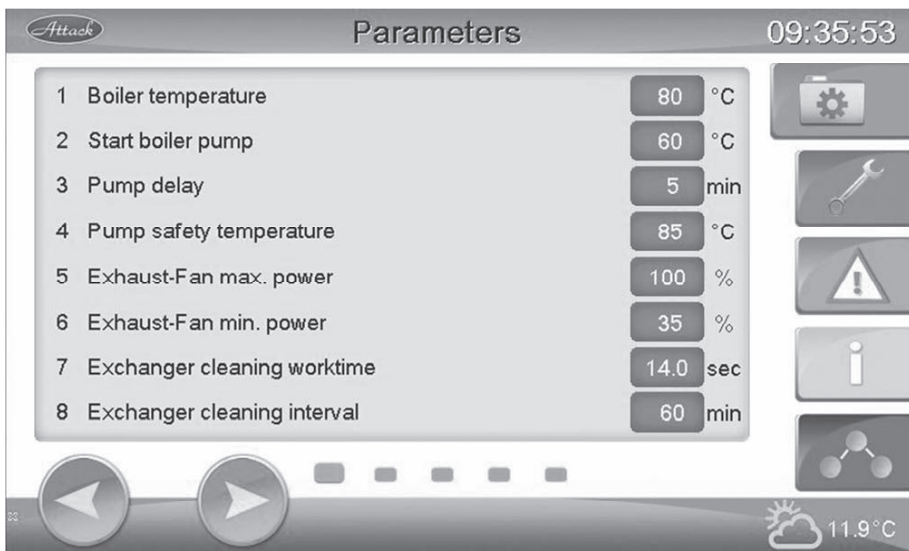

Pic. 54 Advanced parameters, page 1

Boiler temperature – the boiler should reach this temperature.

Start boiler pump – the pump will be switched on after reaching this temperature

Pump delay – pump off time after boiler shutdown

Maximum power of burner – determines the output of the burner

Exhaust – fan maximum power – determines the maximum output of the exhaust fan

Exhaust – fan minimum power – determines the minimum output of the exhaust fan

Exchanger cleaning worktime – is time that the exchanger will be cleaned by turbulators

Exchanger cleaning interval – determines how often the exchanger has to be automatically cleaned by turbulators

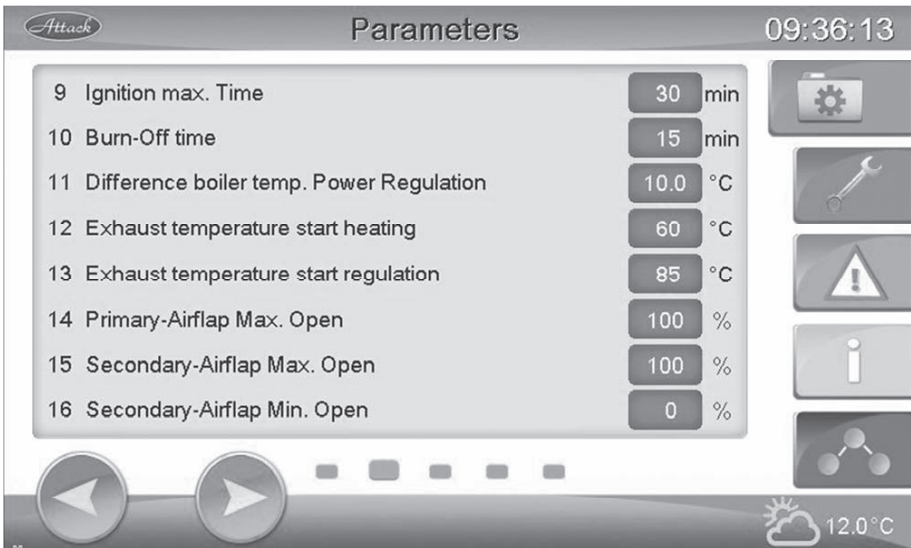

Pic. 55 Advanced parameters, page 2

Ignition max. time – is the time during which the boiler must go to the pre – heating phase after ignition. If this does not happen during this time, the boiler will shut down and report a lack of fuel

Burn – Off time – after this time, the boiler goes into the burn – up phase and turns off. Then he reports a lack of fuel.

Difference boiler temp. Power Regulation – determines how much ° C the fan will gradually reduce the speed before reaching the boiler temperature

Exhaust temperature start heating – is the flue gas temperature according to which the boiler evaluates that the wood has been successfully ignited

Exhaust temperature start regulation – is the temperature at which the controller starts to control secondary air based on the oxygen content of the flue gas. At this temperature the boiler goes into the control phase.

Primary – Airflap Max. Open – is the maximum opening of the primary flap

Secondary – Airflap Max. open – is the maximum opening of the secondary flap

Secondary – Airflap Min. open – is the minimum opening of the secondary flap

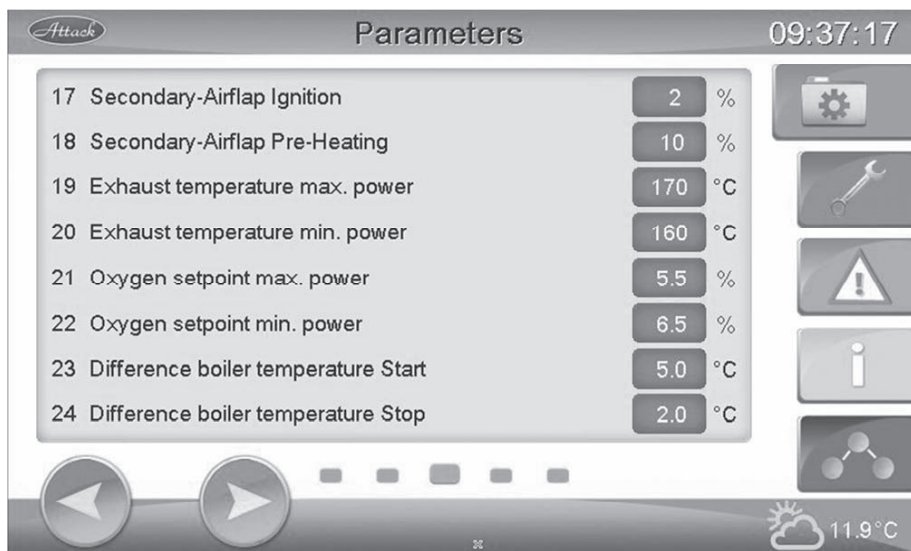

Pic. 56 Advanced parameters, page 3

Secondary – Airflap Ignition – opening the secondary flap in the ignition phase

Secondary – Airflap Pre – Heating – opening of the secondary flap in the pre – heating phase

Exhaust temperature max. power – the flue gas temperature that the boiler should reach at maximum power. This temperature depends on the boiler output and its values are:

Typ kotla – teplota	Typ kotla – teplota
20SLX – 165 °C	40SLX – 160 °C
25SLX – 170 °C	45SLX – 165 °C
30SLX – 175 °C	50SLX – 175 °C
35SLX – 180 °C	55SLX – 185 °C

Exhaust temperature min. power – minimum flue gas temperature which is automatically set by the boiler in case it must work at reduced power. For boiler's regulation of its output the recommended minimum temperature is 160 °C. The minimum flue gas temperature must be set over 150 °C to prevent flue gas condensation in the chimney.

Oxygen setpoint max. power – the oxygen value by which the boiler will control the combustion process at maximum power

Oxygen setpoint min. power – the oxygen value by which the boiler will control the combustion process at minimum power

Difference boiler temperature Start – is the temperature by which, when the boiler temperature drops, the exhaust fan is switched on

Difference boiler temperature Stop – when the boiler temperature rises above the set temperature by this hysteresis, the exhaust fan is shut down

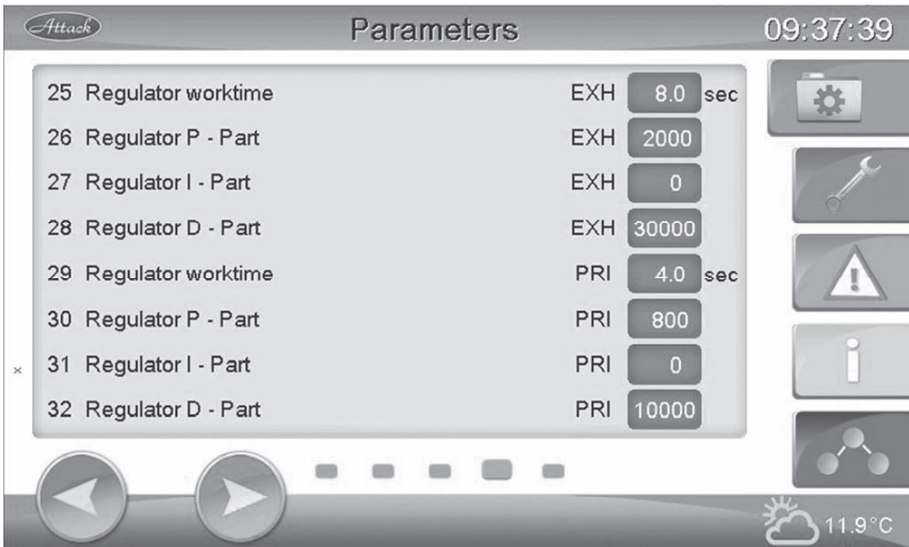

Pic. 57 Advanced parameters, page 4

Regulator worktime (EXH) – PID control model conversion time

Regulator P – part (EXH) – proportional part of the PID control model of flue gas temperature

Regulator I – part (EXH) – integral part of the PID control model of flue gas temperature

Regulator D – part (EXH) – differential part of the PID control model of flue gas temperature

Regulator worktime (PRI) – PID control model conversion time of primary – airflap

Regulator P – part (PRI) – proportional part of the PID control model of primary – airflap

Regulator I – part (PRI) – integral part of the PID control model of primary – airflap

Regulator D – part (PRI) – differential part of the PID control model of primary – airflap



Pic. 58 *Advanced parameters, page 5*

Regulator worktime (SEC) – PID control model conversion time of secondary – airflap

Regulator P – part (SEC) – proportional part of the PID control model of secondary – airflap

Regulator I – part (SEC) – integral part of the PID control model of secondary – airflap

Regulator D – part (SEC) – differential part of the PID control model of secondary – airflap

Exhaust temperature Stop – if the flue gas temperature falls below this value for 15 min. or the oxygen content of the flue gas will be greater than 14% for 15 minutes, the boiler will shut down and the display will indicate that there is a lack of fuel in the boiler. By setting this value to a higher value, you can influence the remaining amount of carbons in the boiler loading chamber for easier subsequent heating. The higher the value, the greater the amount of hot coals that remain

Exhaust temperature Stop – is the value below which when the flue gas temperature drops, the boiler will report a lack of fuel

Set night from (hour) – if the heating circuit is connected we determine the hour of night start when the heating circuit can reduce the temperature

Set night to (hour) – if the heating circuit control is connected we determine the hour of night termination

14 ELECTRICAL SCHEMES

14.1 ATTACK SLX PROFI

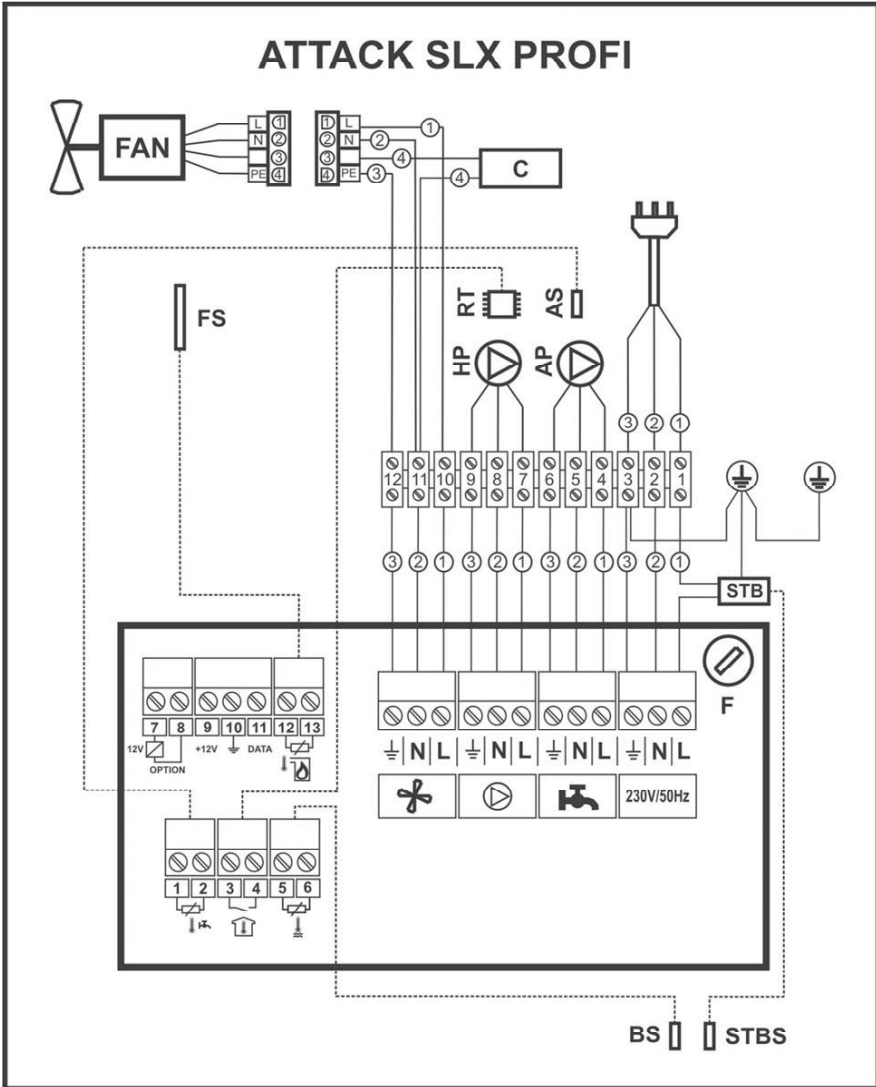

STB – Emergency thermostat, **F** – Fuse (2 A), **C** – Condensator, **HP** – Circulatory pump, **RT** – Spatial thermostat, **BS** – boiler sensor, **STBS** – STB Sensor, **AP** – Auxiliary pump, **AS** – Auxiliary pump sensor, **FS** – Flue gas temperature sensor, **FAN** – Fan

Cable description : **1** – Black conductor, **2** – Blue conductor, **3** – Green – yellow conductor, **4** – Red conductor

14.2 ATTACK SLX LAMBDA TOUCH

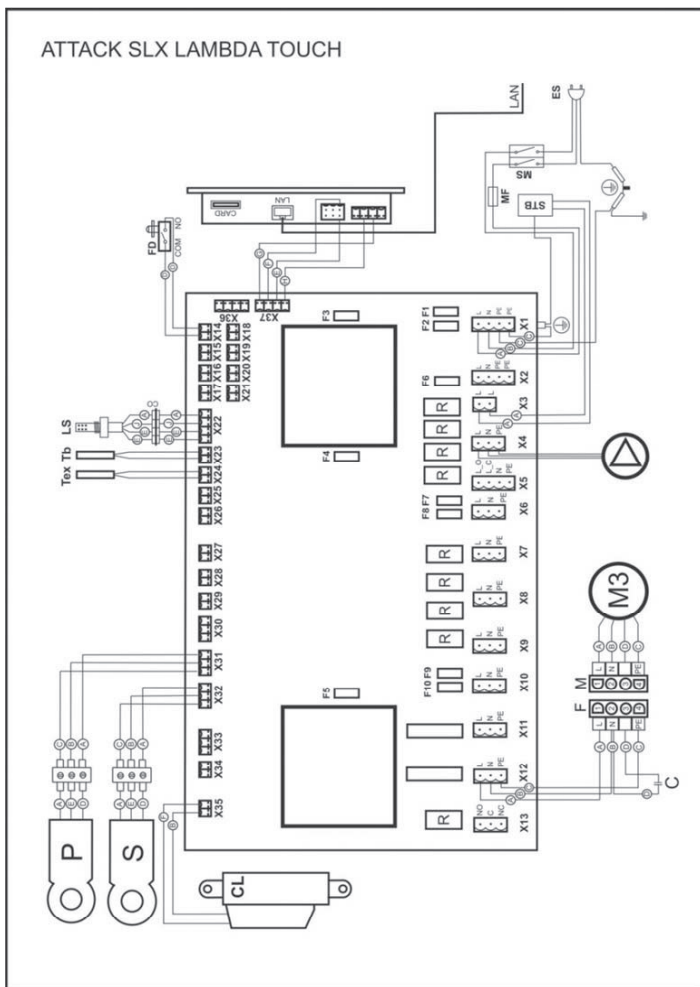

Caption of electrical scheme:

CL – engine of turbulator cleaning, **F** – female, **M** – male, **P** – servoengine of primary air, **S** – servoengine of secondary air, **M3** – exhaust fan, **FD** – terminal switch of feeding chamber door, **CARD** – place for placing memory card with software, **LAN** – place of internet connection, **STB** – emergency thermostat, **Tex** – flue gas temperature sensor, **Tb** – boiler temperature sensor, **LS** – lambda probe, **L** – phase, **N** – neutral, **PE** – grounding,

Cable description : **A** – black, **B** – blue, **C** – green – yellow, **D** – red, **E** – white, **F** – brown, **G** – yellow, **H** – green, **J** – gray

Connectors X26 a X25 are intended for connecting connectors into accumulation tanks (X26 – middle sensor, X25 – upper sensor). Connector X13 is intended for connecting of automatic boiler.

15 RECOMMENDED SCHEMES OF CONNECTION

15.1 CONNECTION OF THE BOILER WITH 1 HEATING CIRCUIT WITH DHW

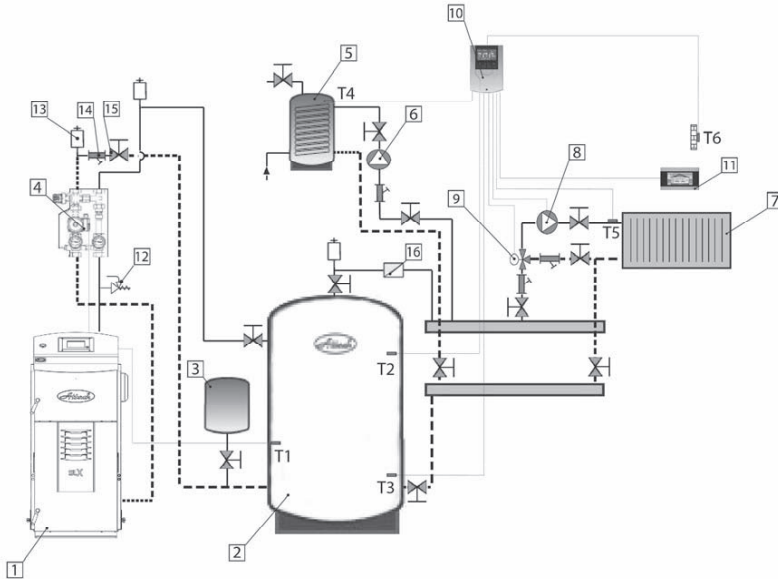

- 1 Wood gasifying boiler ATTACK SLX with regulation PROFI PID
- 2 Accumulation tank ATTACK
- 3 Expanse vessel
- 4 Mixing device ATTACK OVENTROP with pump class A
- 5 Tank for DHW
- 6 Pump of tank for DHW (WILO YONOS PARA RS25/6 130 mm, WILO YONOS PARA RS 25/6 RKC 180mm)
- 7 Set of radiators ATTACK K, VK
- 8 Pump of heating circuit of radiators (WILO YONOS PARA RS25/6 130 mm; WILO YONOS PARA RS25/6 RKC 180 mm)
- 9 Three – way mixing valve of radiators (DN20, KVS 2,5; DN20, KVS 4,0; DN20, KVS 6,3; DN20, KVS 10; DN32, KVS 16; DN40, KVS 25; DN50, KVS 40)
- 10 Regulator 1 mixing circuit TECH CS – 431N
- 11 Room regulator (TECH CS – 292 V3, CS – 296 with RS communication, CS – 282 with RS communication)
- 12 Safety valve
- 13 Deaeration valve
- 14 Filter
- 15 Ball tap
- 16 Return(backflow) valve
- T1 Boiler temperature sensor in accumulation tank
- T2,3 Additional temperature sensor in accumulation tank
- T4 Additional temperature sensor in DHW tank
- T5 Additional temperature sensor in radiators
- T6 Additional sensor of external temperature

15.2 CONNECTION OF THE BOILER WITH 1 HEATING CIRCUIT WITHOUT DHW

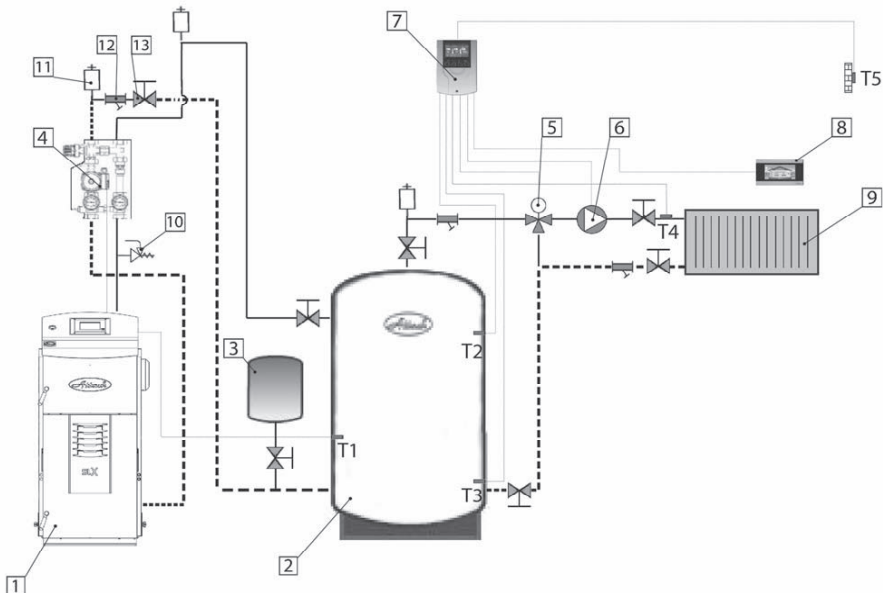

- 1 Wood gasifying boiler ATTACK SLX with regulation PROFI PID
- 2 Accumulation tank ATTACK
- 3 Expanse vessel
- 4 Mixing device ATTACK OVENTROP with pump class A
- 5 Three – way mixing valve of radiators (DN20, KVS 2,5; DN20, KVS 4,0; DN20, KVS 6,3; DN20, KVS 10; DN32, KVS 16; DN40, KVS 25; DN50, KVS 40)
- 6 Pump of heating circuit of radiators (WILO YONOS PARA RS25/6 130 mm; WILO YONOS PARA RS25/6 RKC 180 mm)
- 7 Regulator 1 mixing circuit TECH CS – 431N
- 8 Room regulator (TECH CS – 292 V3, CS – 296 with RS communication, CS – 282 with RS communication)
- 9 Set of radiators ATTACK K, VK
- 10 Safety valve
- 11 Deaeration valve
- 12 Filter
- 13 Ball tap
- T1 Boiler temperature sensor in accumulation tank
- T2,3 Additional temperature sensor in accumulation tank
- T4 Additional temperature sensor in radiators
- T5 Additional sensor of external temperature

15.3 CONNECTION OF THE BOILER WITH 2 HEATING CIRCUITS WITHOUT DHW

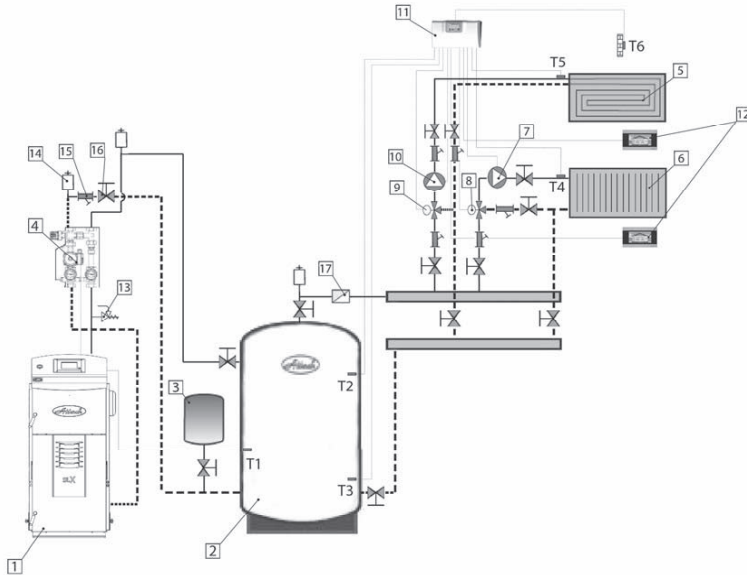

- 1 Wood gasifying boiler ATTACK SLX with regulation PROFI PID
- 2 Accumulation tank ATTACK
- 3 Expanse vessel
- 4 Mixing device ATTACK OVENTROP with pump class A
- 5 Floor heating system
- 6 Set of radiators ATTACK K, VK
- 7 Pump of heating circuit of radiators (WILO YONOS PARA RS25/6 130 mm; WILO YONOS PARA RS25/6 RKC 180 mm)
- 8 Three – way mixing valve of radiators (DN20, KVS 2,5; DN20, KVS 4,0; DN20, KVS 6,3; DN20, KVS 10; DN32, KVS 16; DN40, KVS 25; DN50, KVS 40)
- 9 Three – way mixing valve of the floor heating (DN20, KVS 2,5; DN20, KVS 4,0; DN20, KVS 6,8; DN25, KVS 10; DN32, KVS 16; DN40, KVS 25; DN50, KVS 40)
- 10 Pump of floor heating circuit (WILO YONOS PARA RS25/6 RKC 130 mm, WILO YONOS PARA RS25/6 RKC 180 mm)
- 11 Regulator of 2 heating circuits TECH CS – 408N
- 12 Room regulator with RS communication TECH CS – 282, CS – 292 V3, CS – 296 (always only 1 with RS communication)
- 13 Safety valve
- 14 Deaeration valve
- 15 Filter
- 16 Ball tap
- 17 Return(backflow) valve
- T1 Boiler temperature sensor in accumulation tank
- T2,3 Additional temperature sensor in accumulation tank
- T4 Additional temperature sensor in radiators
- T5 Additional temperature sensor in floor
- T6 Additional sensor of external temperature

15.4 CONNECTION OF THE BOILER WITH 2 HEATING CIRCUITS WITH DHW

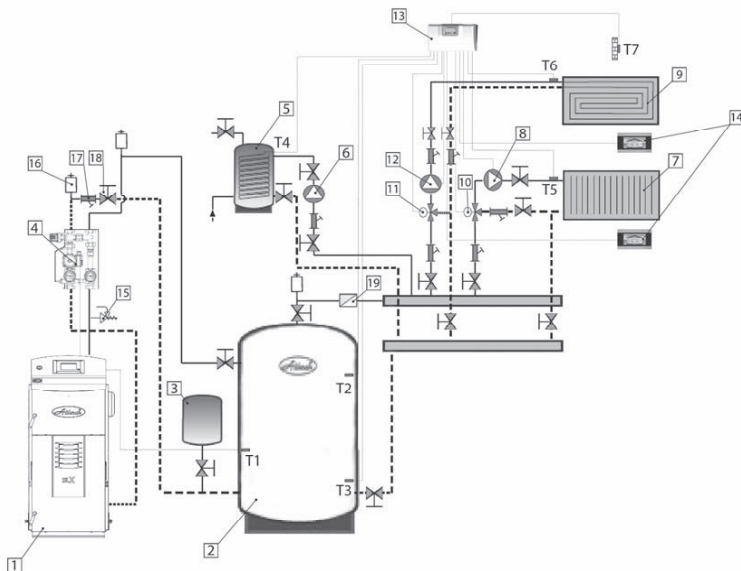

- 1 Wood gasifying boiler ATTACK SLX with regulation PROFI PID
- 2 Accumulation tank ATTACK
- 3 Expanse vessel
- 4 Mixing device ATTACK OVENTROP with pump class A
- 5 Tank for DHW
- 6 Pump of tank for DHW (WILO YONOS PARA RS25/6 130 mm, WILO YONOS PARA RS 25/6 RKC 180mm)
- 7 Set of radiators ATTACK K, VK
- 8 Pump of heating circuit of radiators (WILO YONOS PARA RS25/6 130 mm; WILO YONOS PARA RS25/6 RKC 180 mm)
- 9 Floor heating system
- 10 Three – way mixing valve of radiators (DN20, KVS 2,5; DN20, KVS 4,0; DN20, KVS 6,3; DN20, KVS 10; DN32, KVS 16; DN40, KVS 25; DN50, KVS 40)
- 11 Mixing valve of floor
- 12 Pump of floor heating circuit (WILO YONOS PARA RS25/6 RKC 130 mm, WILO YONOS PARA RS25/6 RKC 180 mm)
- 13 Regulator of 2 heating circuits TECH CS – 408N
- 14 Room regulator with RS communication TECH CS – 282, CS – 292 V3, CS – 296 (always only 1 with RS communication)
- 15 Safety valve
- 16 Deaeration valve
- 17 Filter
- 18 Ball tap
- 19 Return(backflow) valve
- T1 Boiler temperature sensor in accumulation tank
- T2,3 Additional temperature sensor in accumulation tank
- T4 Additional temperature sensor in DHW tank
- T5 Additional temperature sensor in radiators
- T6 Additional temperature sensor in floor
- T7 Additional sensor of external temperature

THE ORIGINAL ES DECLARATION OF CONFORMITY

POZ – 054/07092017

I, Rudolf Bakala, the corporate representative of the ATTACK, s.r.o. company, declare, that the products mentioned below fulfil requirements of the technical prescriptions, under conditions specified for using they are safe, they are produced in conformity with technical documentation and with the norms and regulations given in this document.

Manufacturer: **ATTACK, s.r.o.**, Dielenská Kružná 5020, 03861 Vrútky, Slovak Republic
Place of manufacture: **ATTACK, s.r.o.**, Dielenská Kružná 5020, 03861 Vrútky, Slovak Republic
Product: Warm – water boiler for solid fuel
Type: **ATTACK SLX 20 STANDARD, ATTACK SLX 20 PROFI, ATTACK SLX 20 LAMBDA
ATTACK SLX 25 STANDARD, ATTACK SLX 25 PROFI, ATTACK SLX 25 LAMBDA
ATTACK SLX 30 STANDARD, ATTACK SLX 30 PROFI, ATTACK SLX 30 LAMBDA
ATTACK SLX 35 STANDARD, ATTACK SLX 35 PROFI, ATTACK SLX 35 LAMBDA
ATTACK SLX 40 STANDARD, ATTACK SLX 40 PROFI, ATTACK SLX 40 LAMBDA
ATTACK SLX 45 STANDARD, ATTACK SLX 45 PROFI, ATTACK SLX 45 LAMBDA
ATTACK SLX 50 STANDARD, ATTACK SLX 50 PROFI, ATTACK SLX 50 LAMBDA
ATTACK SLX 55 STANDARD, ATTACK SLX 55 PROFI, ATTACK SLX 55 LAMBDA**

Description:

Warm – water boiler for wood logs combustion. It is intended to be a heat source for dwelling houses and similar objects. The boiler is constructed to work on principle of wood gasification by utilization of the exhaust fan, which sucks the flue into the chimney.

The following European Directives are related to the products:

- Directive of the European Parliament and the Council 2014/35/ES
- Directive of the European Parliament and the Council 2014/30/ES
- Directive of the European Parliament and the Council 2014/68/ES
- Directive of the European Parliament and the Council 2006/42/ES

List of the Harmonized Norms, used by consideration of conformity:

- STN EN 60335 – 1 ed.2:2003 – Electrical appliances for households and the like – Safety – Part 1: General requirements
- STN EN 60335 – 2 – 102:2007 – Electrical appliances for households and the like – Safety – Part 2 – 102: Specific requirements for appliances burning gaseous, petroleum and solid fuels containing electrical connections
- STN EN 62233:2008 – Methods of measuring electromagnetic fields of appliances for households and similar devices with regard to exposure of persons
- STN EN 55014 – 1 ed.3:2007 – Electromagnetic compatibility – Requirements for appliances for households, power tools and similar appliances – Part 1: Radiation
- STN EN 55014 – 2:1998 – Electromagnetic compatibility – Requirements for appliances for households, power tools and similar appliances – Part 2: Resistance– Norm for group of products
- STN EN 61000 – 3 – 2 ed.3:2006 – Electromagnetic compatibility (EMC) – Part 3 – 2: Limits – Limits of radiation of harmonic parts of current (devices with input phase current ≤ 16 A)
- STN EN 61000 – 3 – 3 ed.2:2009 – Electromagnetic compatibility (EMC) – Part 3 – 3: Limits – Limiting changes, voltage fluctuations and flicker in low voltage public grids for equipment with rated current ≤ 16 A, which is not subject to a conditional connection
- STN EN 61000 – 6 – 3 ed.2:2007 – Electromagnetic compatibility (EMC) – Part 6 – 3: Generic Standards – Emissions to the residential, commercial and light industry
- STN EN 62233:2008 – Methods of measuring electromagnetic fields of appliances for households and similar devices with regard to exposure of persons

List of other Harmonized Norms, used by consideration of conformity:

- STN EN 303 – 5:2012, ČSN 06 1008:1997

Notified body, who performed tests and judgement of conformity:

STROJIRENSKÝ ZKUŠEBNÍ ÚSTAV, s.p., Hudcova 56b, 621 00 BRNO, Czech Republic, Notified body 1015

Notified body, performing inspections and control of the quality system:

STROJIRENSKÝ ZKUŠEBNÍ ÚSTAV, s.p., Hudcova 56b, 621 00 BRNO, Czech Republic, Notified body 1015

Last double figure of the year, when the CE marking was placed on the product: 17

In Vrútky: 07.09.2017

.....
Rudolf Bakala, Executive manager ATTACK, s.r.o. Vrútky



WOOD GASIFYING BOILER ATTACK® SLX, DPX



USER MANUAL
for correct installation,
operation and cleaning



WWW.ATTACK.SK

Important! Read this manual properly before the boiler start-up!

CONTENTS

1. INSTALLATION AND CHIMNEY PARAMETERS.....	4
2. VERIFICATION OF THE CORRECT CHIMNEY PARAMETERS	5
3. DEVICES FOR CHIMNEY DRAUGHT MEASURING	6
4. OPERATION PRESSURE IN HYDRAULIC CIRCUIT	7
5. BOILER PROTECTION AGAINST EXCESSIVE CONDENSATION – ATTACK-OVENTROP	7
6. CORRECT ASHTRAYS POSITION.....	8
7. FUEL.....	8
8. AFTERCOOLING CIRCUIT INSTALLATION	9
9. CORRECT ADJUSTMENT OF AIR INLETS.....	9
10. ASHTRAY CLEANING.....	10
11. HOW TO CLEAN SPACE AROUND THE ASHTRAY	12
12. EXCHANGER PIPES CLEANING BY LEVER OF TURBULATORS	13
13. HOW TO CLEAN SPACE UNDER EXCHANGER	14
14. POSITION OF LEVER OF TURBULATORS BY CLEANING	15
15. TOOLS FOR CLEANING OF SPACE UNDER EXCHANGER.....	16
16. CONTROL OF TUBULAR EXCHANGER’S FUNCTIONALITY	17
17. ACCESS TO TUBULAR EXCHANGER	17
18. EXCHANGER’S COVER REMOVAL	18
19. CONTROL OF CORRECT FUNCTION OF THE HEAT-UP FLAP	18
20. TURBULATOR THREADS CLEANING.....	19
21. CLEANING OF THE VENTILATOR’S OPERATION AREA	20
22. CLEANING OF RADIAL IMPELLER’S VANES.....	21
23 SUMMARY OVERVIEW OF REGULAR CLEANING OF PARTICULAR BOILER PARTS	22

1. INSTALLATION AND CHIMNEY PARAMETERS

By installation of chimney connection to boiler it is necessary to care about correct outlet of flue gas and eventual condensate, not to let it fall back into the boiler. For this purpose you can use the T-piece, see picture below. Exhaust connection comes into the chimney vent. If it is not possible to connect boiler to chimney vent directly, then the adequate extension of exhaust connection has to be as short as possible, and no longer than 1 m, without additional heating surface and it has to go up in direction to the chimney. Exhaust connections must not go through foreign dwelling or utility units. Internal cross-section of the exhaust connection must not taper in direction to the chimney. Try to minimize usage of elbows by installation. Chimney has to be constructed in conformity with the norms **STN 73 4201** and **STN 73 4210**.



Prescribed values of the correct height and cross-section chimney dimensions:

<i>DPX15, DPX25, DPX35, DPX45</i>	
<i>20x20 cm</i>	<i>min height 7 m</i>
<i>Ø 20 cm</i>	<i>min. height 8 m</i>
<i>15x15 cm</i>	<i>min height 11 m</i>
<i>Ø 16 cm</i>	<i>min height 12 m</i>

2. VERIFICATION OF THE CORRECT CHIMNEY PARAMETERS

Correct boiler function significantly depends on quality chimney with correct parameters. Minimum chimney diameter is 150 mm, however, 200 mm is recommended. Chimney has to be designed or regulated to achieve prescribed draught of 23–30 Pa at nominal boiler flue gas temperature value.



ATTENTION! Chimney which does not fulfil required parameters may cause limited boiler function (Low flue gas temperature, low output, excessive condensation of tubular exchanger, shorter life-time, even total boiler disfunction)! Guarantee does not relate to the boiler installed with the chimney of incorrect parameters.

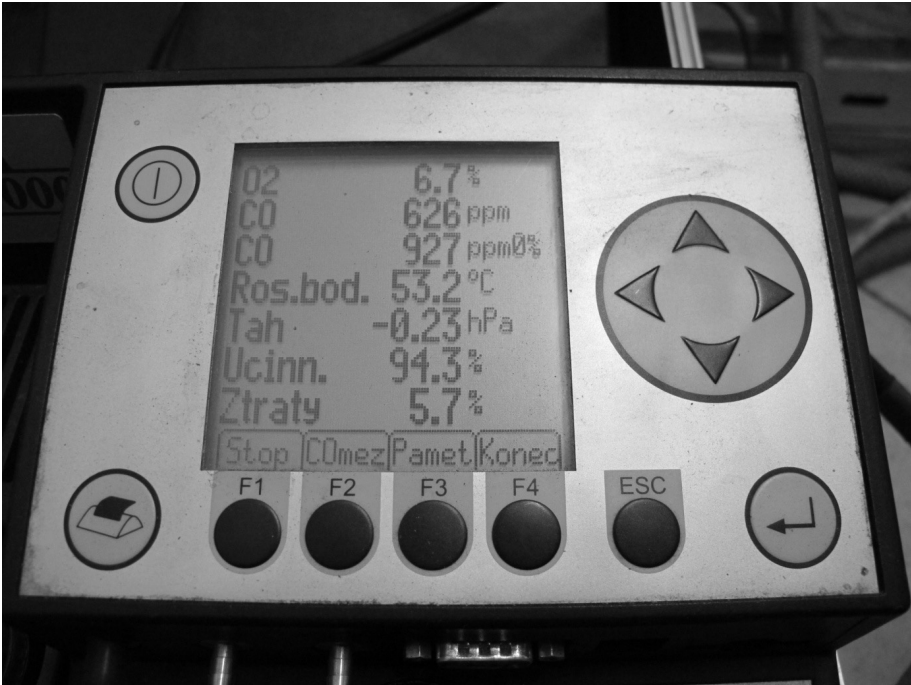

3. DEVICES FOR CHIMNEY DRAUGHT MEASURING

It is possible to check correct chimney draught by some types of analysers or by exact differential pressure-gauge. On the picture there is draught reducer too, also useful for correct draught setting.



4. OPERATION PRESSURE IN HYDRAULIC CIRCUIT



Operation pressure must not exceed limit of 2,5 bar.

ATTENTION! Expanse vessel and safety valve must be installed in the system.



5. BOILER PROTECTION AGAINST EXCESSIVE CONDENSATION – ATTACK-OVENTROP

For correct boiler function and its long life-time it is necessary to keep return water temperature always higher than 65 °C. Set boiler thermostat to 80-85 °C, which is ideal boiler operation temperature. Boiler guarantee is valid only in case that the ATTACK-OVENTROP device was installed into the hydraulic system.



ATTENTION! If the ATTACK OVENTROP device is not installed, it may cause shorter boiler life-time.



6. CORRECT ASHTRAYS POSITION

Ashtray position is important for correct boiler operation. It is not necessary to take out the ashtray while cleaning, but it is important to check its correct position sometimes. Ashtray has to be completely shifted rearwards.



7. FUEL

Use suitable fuel for wood gasifying boiler operation – soft or hard wood logs. Wood moisture has to be in range of 12–20 % (related to time of min. 15 month of free storing at the fresh air). Alternatively it is possible to use wood briquets of cylindrical shape with opening in the middle.



ATTENTION! Wood with moisture exceeding 20 % shortens boiler life-time, causes lower output, excessive condensation in tubular boiler exchanger, which may require additional out-of-warranty service!



8. AFTERCOOLING CIRCUIT INSTALLATION

Boiler warranty is valid only in case, that functional thermostatic valve, connected to the cold water source, is installed in the boiler aftercooling circuit. If the cold water source depends on electricity (home water plant), whole device can be out of order in case of power failure. In this cases, use water tanks placed higher than boiler, connected to thermostatic valve. Tank volume has to be appropriate to the boiler output.



ATTENTION! If there is no aftercooling circuit on the boiler and it comes to boiler overheating, serious and non-recurring damage or even fire may occur.

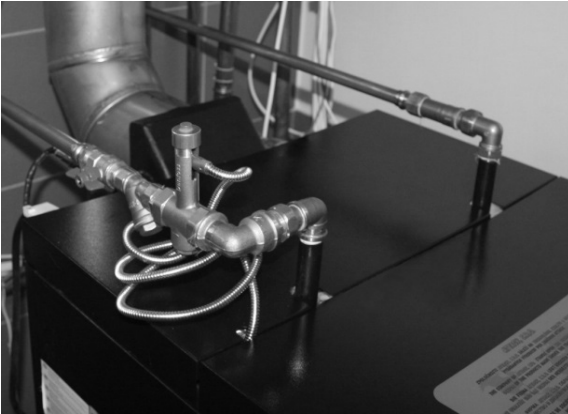

9. CORRECT ADJUSTMENT OF AIR INLETS

Correct adjustment of primary and secondary air by STANDARD and PROFI boilers is marked on tin-plate and it is not necessary to manipulate with that. Correct setting of primary air (upper butterfly) is 100 %, secondary air (bottom butterfly) is set to 35 %. This relates to all outputs of DPX boilers (15, 25, 35, 45).

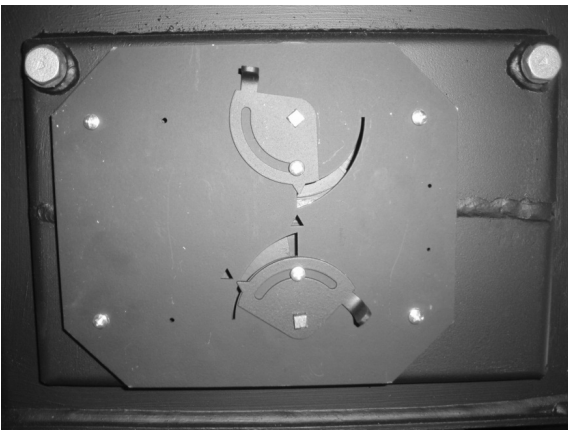

10. ASHTRAY CLEANING

Internal space of ashtray has to be cleaned from accumulated ash at least 1× a day. Cleaning with scoop is very effective and easy. Cleaning can be done very easily and fast also by full boiler operation.



ATTENTION! Hot ash from ashtray can still smoulder, therefore it is not supposed to be put into trash bin, however into appropriate tin-plate bin, not to cause the fire.





11. HOW TO CLEAN SPACE AROUND THE ASHTRAY

Space around the ashtray has to be cleaned regularly, at least 1× a week. Use suitable tool, fire hook delivered with boiler is ideal for this purpose. It is not necessary to take out the refractory pieces from the boiler's ashtray.



ATTENTION! Unsufficiently cleaned space around ashtray may cause limited boiler function.



12. EXCHANGER PIPES CLEANING BY LEVER OF TURBULATORS

It is necessary to move lever of turbulators cleaning regularly, preferably by every boiler loading, at least 3 times a day. It is necessary to move it by full lever uplift, 5–6 times upwards and downwards.



ATTENTION! If it is not moved with the lever regularly, exchanger pipes may clog and therefore cause turbulators blockage, lower efficiency, decreased output and incorrect boiler function. In this case is boiler warranty not valid. If you cannot move the lever of turbulators, stop the boiler and call specialized service.

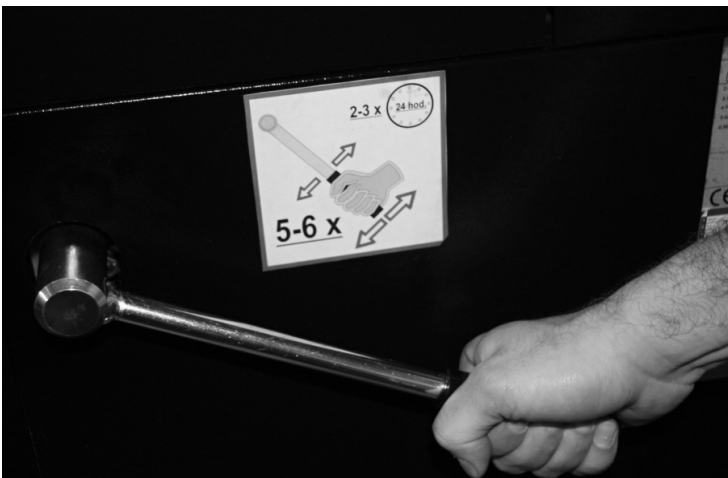
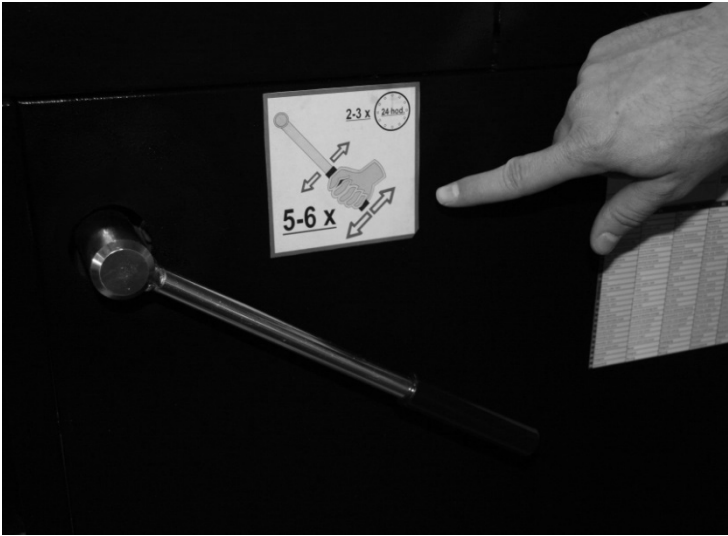

13. HOW TO CLEAN SPACE UNDER EXCHANGER

It is necessary to clean space under exchanger pipes in regular intervals. This interval depends on boiler operation time, but it has to be done at least 1× a week. Remove cover of the opening for cleaning carefully, not to damage the sealing. After cleaning of space under exchanger, install the cover – it has to be sufficiently screwed and air-proof.



ATTENTION! Otherwise there may come to insufficient air circulation in the boiler and thereby to incorrect boiler function (ineffective combustion, decreased output, low flue gas temperature, etc.).

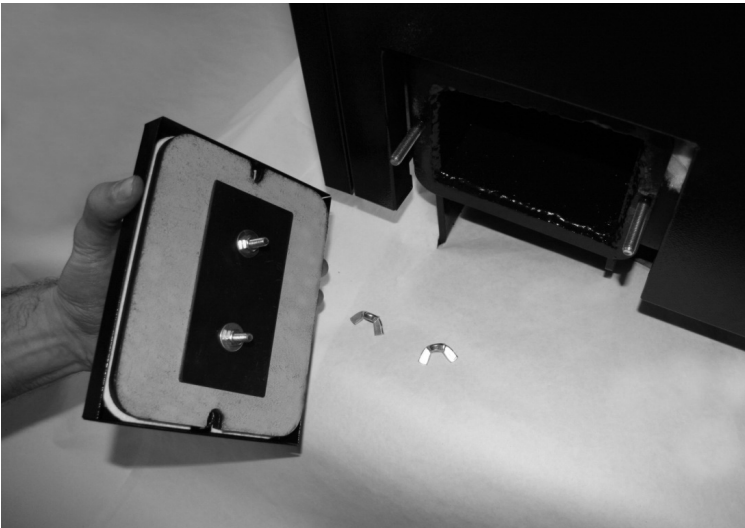

14. POSITION OF LEVER OF TURBULATORS BY CLEANING

To clean space under exchanger of the DPX 15, 25, 35 boilers, it is necessary to lift lever of turbulators fully up, turbulators go into the pipes and thereby there is free space for cleaning. By the DPX 45 boiler it is ideal to lift the lever into middle position.

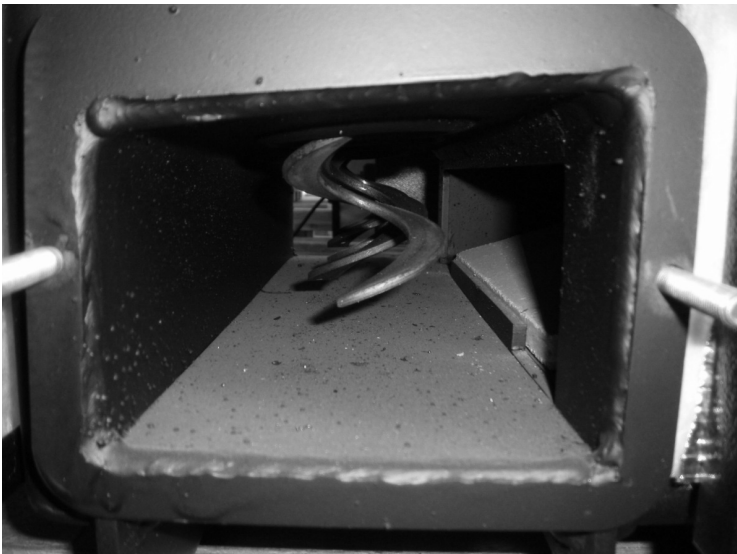
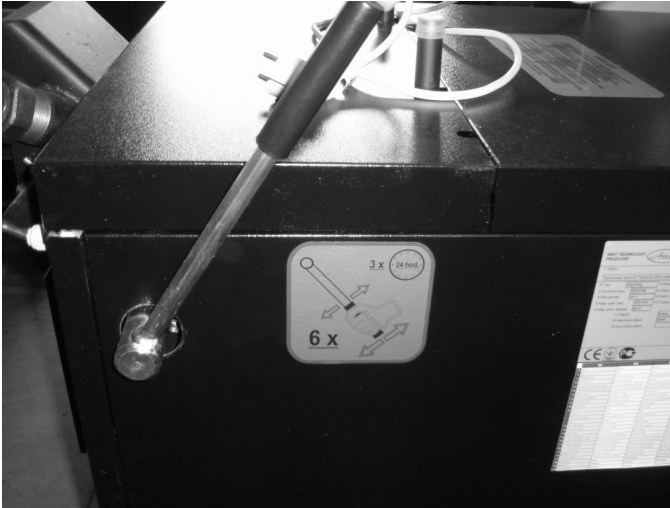

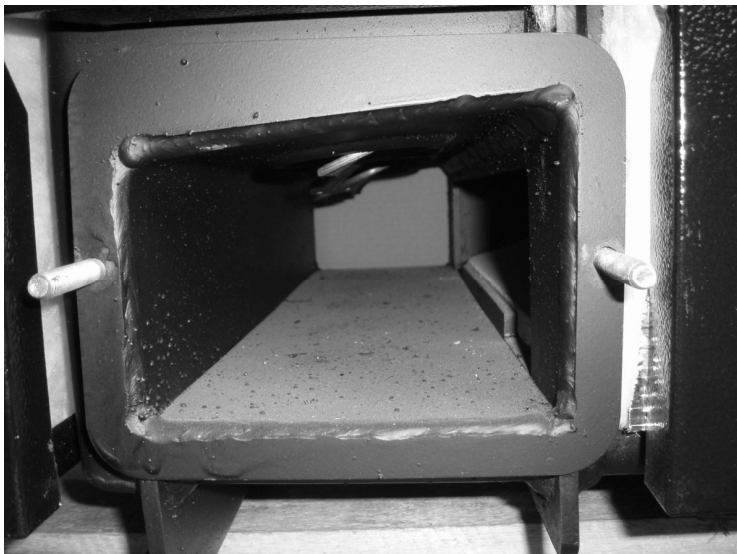

15. TOOLS FOR CLEANING OF SPACE UNDER EXCHANGER

To clean space under exchanger it is possible to use fire hook delivered with the boiler.

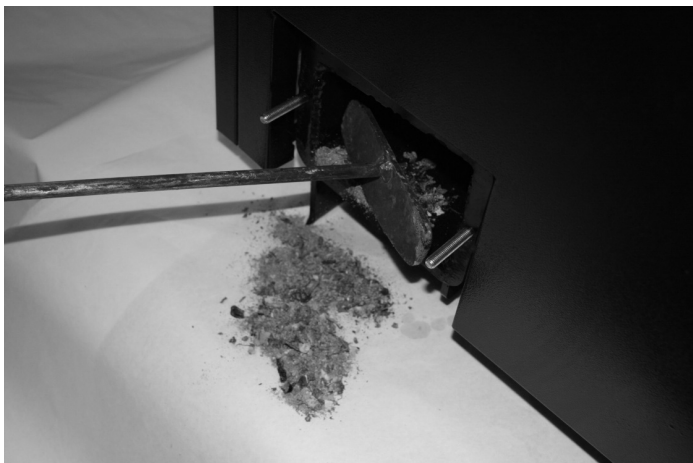

16. CONTROL OF TUBULAR EXCHANGER'S FUNCTIONALITY

Check regularly correct functionality of tubular exchanger – at least 1× a month. Firstly, remove rear upper cover.



17. ACCESS TO TUBULAR EXCHANGER

Release wing matrices.

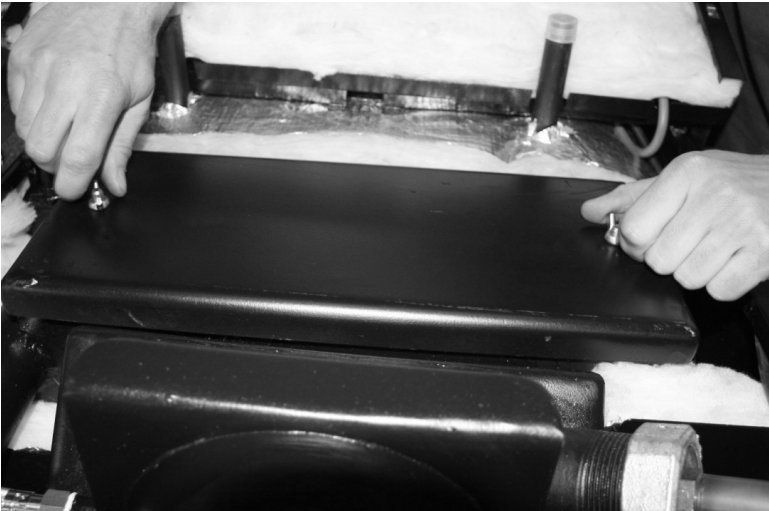

18. EXCHANGER'S COVER REMOVAL

Check correct functionality fo turbulators, while the boiler is out of order. Remove the cover to get to the tubular exchanger.



ATTENTION! Cover must be sufficiently tighten and air-proof. Otherwise it may cause incorrect boiler function



19. CONTROL OF CORRECT FUNCTION OF THE HEAT-UP FLAP

For correct function of the heat-up flap it is necessary to check and clean bearing surfaces regularly.



20. TURBULATOR THREADS CLEANING



If the boiler was from any reason operated in incorrect way, it is possible, that the turbulators were clogged and thereby the flue gas transition was decreased. In this case it is necessary to demount turbulators and to clean the space between particular threads, for example by wire brush. Put the turbulators back into the pipes, not to decrease efficiency of the boiler. (This is not related to the 15 DPX model).

21. CLEANING OF THE VENTILATOR'S OPERATION AREA

Operation space of the ventilator's radial impeller has to be cleaned at least 1× a year. To do so, release matrices of the ventilator's flange and demount ventilator. Clean the operation area from soot and mud. By demounting, take care to tighten matrices of the ventilator's flange sufficiently.



ATTENTION! Demount ventilator, while boiler is out of order. Insufficiently cleaned ventilator's operation area may cause its limited function.



22. CLEANING OF RADIAL IMPELLER'S VANES

Vanes of ventilator have to be cleaned from dirt at least 1× a year by suitable tool (wire brush).



ATTENTION! Too dirty vanes of ventilator decrease its efficiency and thereby cause limited boiler function.

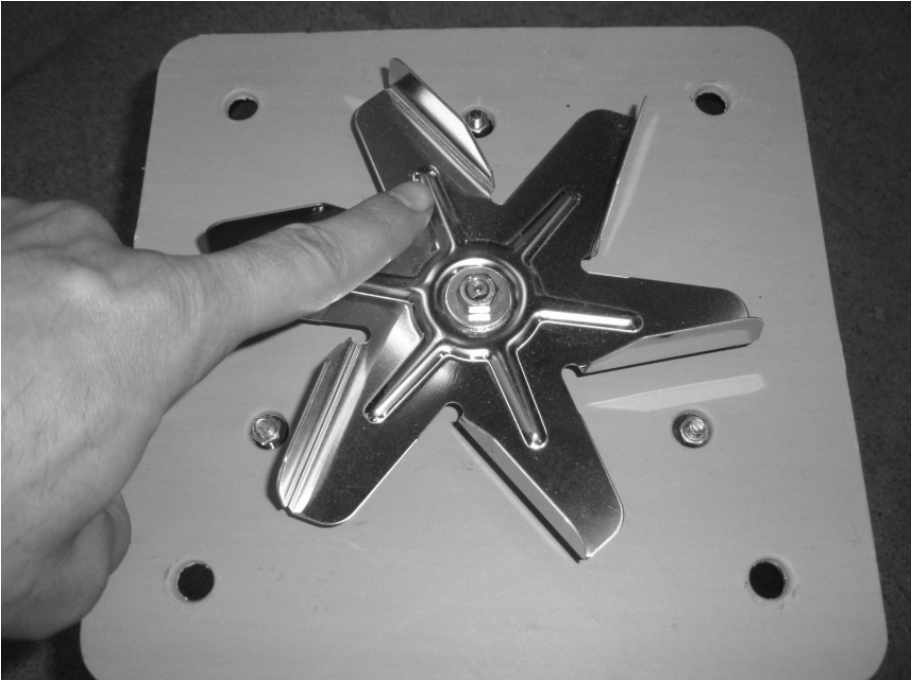

23 SUMMARY OVERVIEW OF REGULAR CLEANING OF PARTICULAR BOILER PARTS

Cleaning*	Point	Daily	Weekly	Annually
Ash removing	10	1×		
Space around ash tray	11		1×	
Space under exchanger	15		1×	
Lever of turbulators	12	5-6×		
Flap	19		1×	
Space of ventilator	21			1×
Radial impeller of ventilator	22			1×

* Minimal recommended cleaning intervals. According to intensity of heating they can be also shorter.

Information about processing of personal data

Dear Customer,

You provide us your personal information by completing and sending the Boiler start-up record and our company becomes your personal data manager in relation to you.

We hereby would like to inform you why and how we process your personal information, how we collect your personal information, for what purpose we handle it and the legal basis of such processing, how we handle personal data and what your rights are in relation to processing your personal data.

Please read the following information carefully before providing us your personal details.

In case of any questions related to the processing of your personal data, please do not hesitate to contact us at tel. no. +421 43 400 3103 or gdpr@attack.sk.

Privacy Manager:

ATTACK, s. r. o., with its registered office at Dielenská Kružná 5020, 038 61 Vrútky,

Slovak Republic

Tel.: +421 43 4003 103

E-mail: exporten@attack.sk

Web: <https://www.attack.sk>

Processing of personal data

We will only process the personal information you provide to us in the Boiler start-up record, i.e.:

- Name
- Surname
- Address
- Phone
- Type and serial number of the product

Purpose and legal basis for the processing of your personal data

We will process your personal data for the following purposes and on the basis of the following legal bases.

- 1) For the purposes of direct marketing, which is a legitimate interest of our company. The legal basis here is Art. Article 6 1. Letter. (f) Regulation (EU) 2016/679 of the European Parliament and of the Council of 27 April 2016 on the protection of natural persons with regard to the processing of personal data and on the free movement of such data, and repealing Directive 95/46/EC (General Data Protection Regulation).

The processing based on our legitimate interest, i.e. direct marketing, is following:

Your personal data will be stored in our electronic database which is managed directly and only by us. This electronic database is stored and secured on the property of our company. Your personal data will be used by our legitimate interest only in order to be able to send you an offer of our new products, especially in the event of the end of the expected life of product which you enter your personal data in the Boiler start-up record in if our company develops a newer and more technologically superior and better product that could replace the product in which you enter your personal data into the in the Boiler start-up record.

Direct marketing is our legitimate interest and the one of two purposes of processing of

- your personal data, i. e. direct offer of our products sent to you.
- 2) The legal basis for fulfilling the extended warranty agreement on the product in which you enter the Boiler Startup Record where your personal data is Art. Article 6 1. Letter. (f) Regulation (EU) 2016/679 of the European Parliament and of the Council of 27 April 2016 on the protection of natural persons with regard to the processing of personal data and on the free movement of such data, and repealing Directive 95/46/EC (General Data Protection Regulation).

This processing that is required to meet the extended warranty agreement for a product you are one of the parties will be following:

Our company provides you with an extended contractual warranty (beyond the statutory warranty) in such situation that you comply with the warranty conditions (see the warranty conditions in the Instruction for use, in which there is the Boiler start-up record with your personal data). In order to provide you with this extended contractual warranty we need to know who is the other party and whether you are performing your obligations under this agreement especially the mandatory annual service inspections. Therefore we need you to send us a record of this inspection after each annual inspection (max. 5 inspections) and we will declare in our database that you fulfill the terms of the contractual guarantee.

Since each contract has at least two contracting parties we need your personal data to identify you as a party and identify a specific product for the purposes of fulfilling the extended warranty agreement. We would not be able to fulfill our obligations under the extended warranty agreement properly without these data.

Our legitimate interest and one of the two purposes of processing your personal data is therefore the fulfillment of the contract, that is, the fulfillment of the contract for extension of the contractual guarantee.

Processing of personal data for both purposes is done manually and also in electronic information systems. However these systems are subject to rigorous and constant physical and technical control. All persons who, on the basis of our instructions and our credentials, come in contact with personal data in the framework of their work or contractual obligations are bound by confidentiality.

Category of recipients of personal data

We process your personal data primarily by ourselves. However it may happen that we will have to use the services of another entity to process personal data for any of the above mentioned purposes. In this case the relationship between us and the third party will be the relationship between the administrator and the processor and we will make an agreement with this processor about the processing of the personal data in order to guarantee the security and legality of processing your personal data.

Your personal data may therefore be sold to the recipient of the following categories:

- a) A company that distributes our products in the territory of a member state of the European Union in which you have purchased a product which you enter your personal data in the Boiler start-up record in or in which such a product is put into service on your request
- b) A company providing bulk mailing services

The length of time the personal data will be stored

We will process your personal data for at least the duration of the contractual warranty (i.e. for 5 years) for the purposes of fulfilling the warranty agreement and at most for the time of assumed lifetime of the products for which the Boiler start-up record for the purposes of direct marketing.

Raising objections to processing of personal data

Whenever you have the right to object to our processing of your data for direct marketing purposes (see Purpose and legal basis for processing your personal data, item 1) above). If you have an objection to our processing of your direct marketing data, by the date of your objection will cease our processing your personal data for direct marketing purposes.

The objection to the processing of your personal data for direct marketing purposes can be sent to us by post to:

ATTACK, s. r. o., Dielenská Kružná 5020, 038 61 Vrútky, Slovak Republic. In the objection, it is sufficient to provide the name, address and the text "I hereby raise an objection to the processing of my personal data for the purposes of direct marketing" and your signature. We always inform you about the accepting your request without delay.

Please note that the right to object can not be invoked against our processing of your personal data necessary for the purpose of fulfilling the extended warranty agreement.

Your other rights related to the processing of personal data

Please note that you also have the following rights in relation to our processing of your personal information:

- to ask for information about what personal data is processed by us,
- to request access to these data and let them update or fix,
- to require the deletion of these personal data, or the limitation of their processing,
- to raise objection to the processing of your personal data,
- the right to the portability of your personal data,
- in case of doubt regarding compliance with the obligations related to the processing of your personal data, contact the Administrator or the Office for Personal Data Protection.

You may enforce these rights to our company by the same procedure as the right to raise objections to the processing of personal data.



HEAT TECHNOLOGY MANUFACTURER

ATTACK, s.r.o. • Dielenská Kružná 5020, 038 61 Vrútky • Slovakia

Tel: +421 43 4003 101 • E-mail: kotle@attack.sk

Export – tel: +421 43 4003 115 • E-mail: export@attack.sk



All provided information is temporary, subject to change without notice and for informational purposes only. Variations in product visual display are possible and may not match the offer and range of equipment for different markets. ATTACK s.r.o. reserves the right to make changes to specifications and content without prior notice. Pictures and product specifications are only informative. Price and offer changes are reserved.