

BOLLY® 1 XL

POLYWARM® COATED DOMESTIC HOT WATER CALORIFIER WITH 1 FIXED HEAT EXCHANGER



APPLICATION

Production and storage of domestic hot water (DHW). All the connections are aligned on the front and on the back for quick and easy installation.

MATERIAL

Mild steel Polywarm® coated (Attestation ACS - SSICA - EN 16421 - WRAS)

HEAT EXCHANGER

Mild steel Polywarm® coated heat exchanger.

INSULATION

HARD: High thermal insulation with ecological polyurethane hard foam. SOFT: NOFIRE® polyester fleece 100% made of recyclable material, with high thermal insulation. Fire resistance class B-s2d0 according to EN 13501.

HARD FOAM (CLASS "A" MODELS): rigid polyurethane foam for high thermal insulation with a vacuum sheet of highly insulating material. Grey PVC external lining.

CATHODE PROTECTION

Magnesium anode.

DRAIN

External confluence through drain connection.

GASKET- FLANGE PLATE

Silicone gaskets suitable for water intended for human consumption (tested according to 98/83/CE), max temperature up to 200°C. Mild steel inspection flange plate with Polywarm® and connection for electric heater.

WARRANTY

5 years (See general sales conditions and warranty)

ACCESSORIES AND SPARE PARTS

See Accessories section for the entire list.

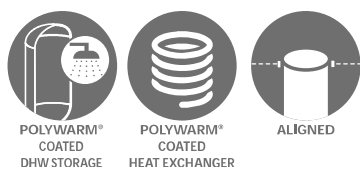

BOLLY® 1 XL WB

Model	HARD FOAM INSULATION	HEAT EXCHANGER SURFACE [m²]	ENERGY EFFICIENCY CLASS
200	3104162330011	2	B
300	3104162330012	3,4	B
400	3104162330013	4,4	C
500	3104162330014	5,4	C
800	3104162330015	6,0	B
1000	3104162330016	6,5	B



cordivari.com/erp

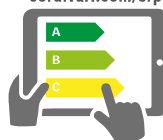

On line ErP label tool



BOLLY® 1 XL WC

Model	DISMOUNTABLE SOFT FLEECE insulation	HEAT EXCHANGER SURFACE [m²]	ENERGY EFFICIENCY CLASS
800	3104162320007	6,0	C
1000	3104162320008	6,5	C



BOLLY® 1 XL WB CLASS A

Model	HARD FOAM INSULATION	HEAT EXCHANGER SURFACE [m²]	ENERGY EFFICIENCY CLASS
200	3104162330051	2	A
300	3104162330052	3,4	A
500	3104162330053	5,4	A

ACCESSORIES

ELECTRIC IMMERSION HEATERS

Mod.	MONOPHASE		
	1,5 kW	2 kW	3 kW
	5240000000051	5240000000052	5240000000053
	Ignition time from 10 °C to 45 °C with electric immersion heaters [min]		
200	159	285	214
300	235	421	316
400	353	632	474
500	413	741	555
800	668	1197	898
1000	874	1565	1174

Mod.	THREEPHASE				
	4 kW	5 kW	6 kW	9 kW	12 kW
	5240000000047	5240000000048	5240000000049	5240000000050	5240000000031
	Ignition time from 10 °C to 45 °C with electric immersion heaters [min]				
	//	//	//	//	//
	158	//	//	//	//
	237	//	//	//	//
	278	222	//	//	//
	449	359	299	199	//
	587	470	391	261	196

HEAT MANAGER kit + electric resistance with probe and 3m cable

Art. Nr.	ELECTRICAL RESISTANCE
5240000000074	1,5 kW
5240000000075	2 kW
5240000000076	3 kW



Titanium electronic anode

For art. nr. and prices please see Accessories section



BOLLY® 1 XL

POLYWARM® COATED DOMESTIC HOT WATER CALORIFIER WITH 1 FIXED HEAT EXCHANGER

Model	STORAGE		HEAT EXCHANGER		
	Pmax	Tmax	Pmax	Tmax	Tmax
200 ÷ 800	10 bar	90 °C	12 bar	110 °C	
1000	8 bar				



CORDIVARI® Lab

TÜV Rheinland Energie und Umwelt GmbH states that test procedures and Cordivari LAB are certified conforming to European standard EN 15332, as indicated by Ecodesign ErP Directive.

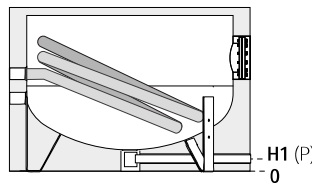
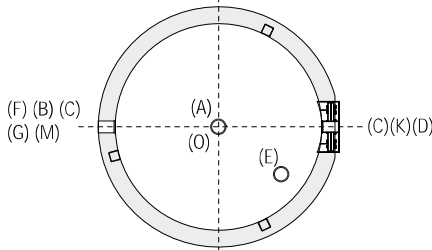
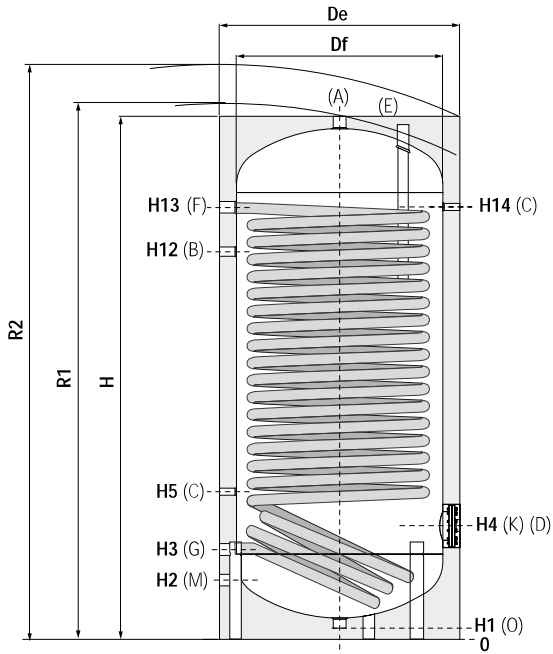
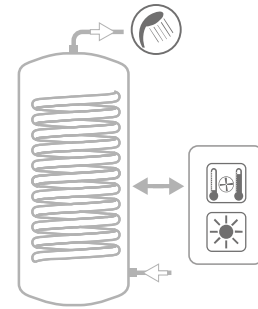

A	Domestic hot water outlet
B	Recirculation
C	Connection for instrumentation 1/2" G F
D	Connection for electric immersion heater
E	Connection for magnesium anode 1"1/4 G F
F	Primary circuit inlet 1"1/4 G F
G	Primary circuit outlet 1"1/4 G F
K	Flange for inspection
M	Domestic cold water circuit inlet
O	Drain 1"1/4 G F
P	Drain for >500 Lt 3/4" G F

CALORIFIERS FOR HEAT PUMPS

BOLLY® 1 XL WB +XL WB CLASS A (HARD FOAM INSULATION)

Model	Volume [lt]	Weight [Kg]	Df	H	H(c.l.A)	De	R2	R2(c.l.A)	H1	H2	H3	H4	H5	H12	H13	H14	K	M	B	A	D
200	188,8	96	//	1440	1440	550	1560	1560	71	215	285	325	405	1055	1190	1190	Ø120/Øe180	Connections F			
300	290,5	130	//	1500	1500	650	1650	1650	71	241	321	381	431	1091	1211	1211	Ø120/Øe180	3/4"	3/4"	1"1/4	1"1/2
400	422	154	//	1780	//	700	1930	//	71	256	336	396	446	1316	1471	1471	Ø120/Øe180	1"	1"	1"1/4	1"1/2
500	497,4	174	//	1800	1850	750	1960	2010	71	266	346	411	466	1326	1486	1486	Ø120/Øe180	1"	1"	1"1/4	1"1/2
800	789,4	264	750	2170	//	900	2360	//	101	338	418	483	538	1548	1808	1808	Ø170/Øe240	1"	1"	1"1/4	2"
1000	1037,9	303	850	2230	//	1000	2460	//	89	359	439	499	559	1584	1829	1829	Ø170/Øe240	1"1/4	1"	1"1/2	2"

BOLLY® 1 XL WC - DISMOUNTABLE SOFT FLEECE INSULATION

Model	Volume [lt]	Weight [Kg]	Df	H	De	R1	R2	H1	H2	H3	H4	H5	H12	H13	H14	K	M	B	A	D
800	789,4	226	750	2190	950	2330	2400	101	338	418	483	538	1548	1808	1808	Ø170/Øe240	1"	1"	1"1/4	2"
1000	1037,9	255	850	2250	1050	2420	2500	89	359	439	499	559	1584	1829	1829	Ø170/Øe240	1"1/4	1"	1"1/2	2"

P.E.D. product designed and produced in conformity to the article 4.3 of directive 2014/68/UE - ErP Ecodesign directive 2009/125/CE



Data have been calculated on following basis:

- 1) Primary circuit at T1 and proper energy source;
- 2) Production of DHW in continuous from 10 °C to t2;
- 3) DHW that can be taken in the first 10' and in the first hour from storage at 60°C, input 10°C and output 45°C;
- 4) Sanitary water according to UNI CTI 8065.

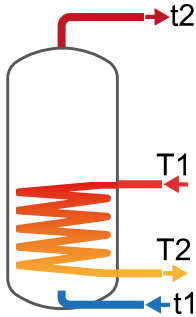

Model	Primary Flow rate [m³/h]	Ignition time (minutes) from 10 °C to t2 and primary at T1				Maximum power exchange (kW) with primary at T1, secondary within 10-45 °C and constant use of DHW production				DHW continuous production lt/h within 10-45 °C and primary at T1			
		T1/t2				T1				T1			
		55/50	65/60	70/60	80/60	55	65	70	80	55	65	70	80
200	2,5	40	42	30	20	21	31	36	47	522	773	899	1153
	1,25	49	52	36	24	19	28	32	40	468	677	780	990
300	3	44	46	32	22	30	45	52	66	751	1104	1281	1640
	1,5	55	57	41	27	27	39	44	56	664	951	1093	1377
400	3,5	47	49	35	23	42	61	71	90	1033	1510	1747	2229
	1,75	59	62	44	30	37	53	60	75	915	1298	1486	1863
500	3,5	49	51	36	24	48	70	81	103	1198	1740	2009	2551
	1,75	62	65	47	31	43	60	68	85	1060	1487	1696	2114
800	5	59	61	43	29	64	93	107	136	1571	2291	2650	3372
	2,5	72	76	55	37	57	80	92	115	1412	1993	2277	2845
1000	8	65	68	48	32	72	106	124	158	1780	2632	3058	3925
	4	76	80	57	38	66	95	110	139	1642	2364	2720	3436

Model	Primary Flow rate [m³/h]	DHW produced in the first 10 minutes in lt/10' input 10 °C output 45 °C, storage at t2 and primary at T1				DHW produced in the first hour in lt/60' input 10 °C output 45 °C, storage at t2 and primary at T1				Heat exchanger pressure drop	
		T1/t2				T1/t2				[mm c.a.]	[mbar]
		55/50	65/60	70/60	80/60	55/50	65/60	70/60	80/60		
200	2,5	221	399	420	462	241	888	989	1193	1062,3	104,2
	1,25	221	383	400	435	238	811	894	1062	309,7	30,4
300	3	340	600	629	689	368	1299	1441	1728	830,2	81,4
	1,5	339	574	598	645	363	1176	1290	1517	243,2	23,8
400	3,5	492	855	894	974	531	1811	2001	2386	1263,9	123,9
	1,75	491	819	850	913	524	1641	1791	2093	370,8	36,4
500	3,5	581	1001	1046	1137	625	2103	2319	2752	1263,9	123,9
	1,75	579	959	994	1064	617	1901	2068	2403	370,8	36,4
800	5	918	1510	1570	1691	977	2962	3249	3826	2976,1	291,9
	2,5	916	1461	1508	1603	967	2723	2950	3405	874,7	85,8
1000	8	1203	1920	1991	2136	1270	3587	3928	4621	7358,7	721,6
	4	1201	1875	1935	2054	1261	3372	3657	4230	2161,9	212,0

HEAT EXCHANGERS PRESSURE DROP

Heat exchangers surface [m²]

200	2
300	3,4
400	4,4
500	5,4
800	6
1000	6,5

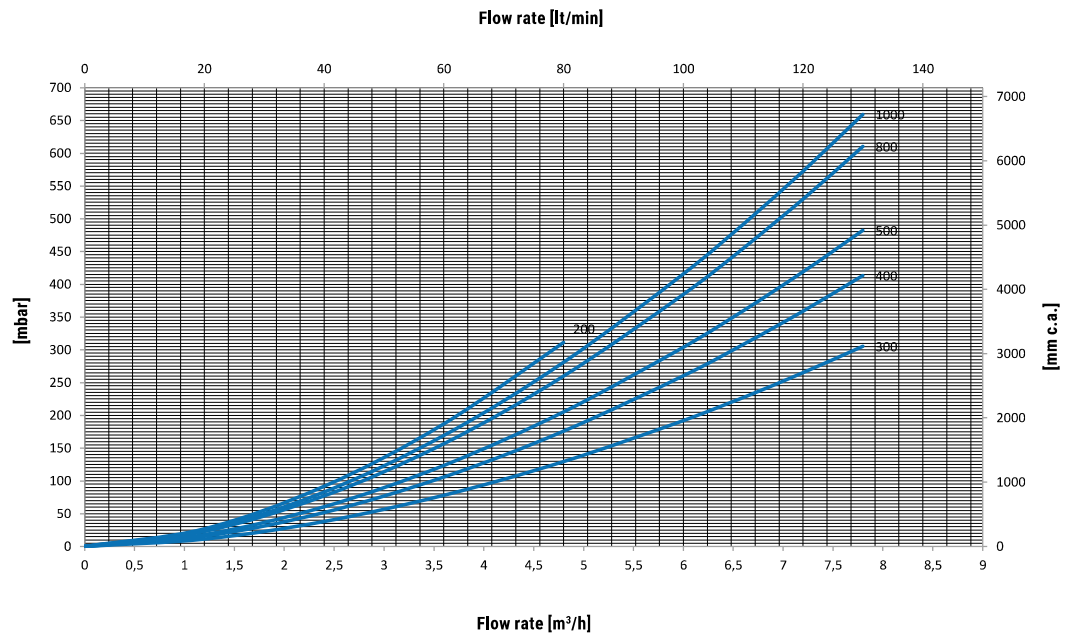



Heat Exchanger output referred to temperature and flow rate of primary circuit and with secondary at 10/45°C at maximum withdrawal of producible DHW (Upper limit of the curves referred to maximum primary flow rate in the heat exchanger, while the lower limit in the curves refer to the minimum primary flow rate)

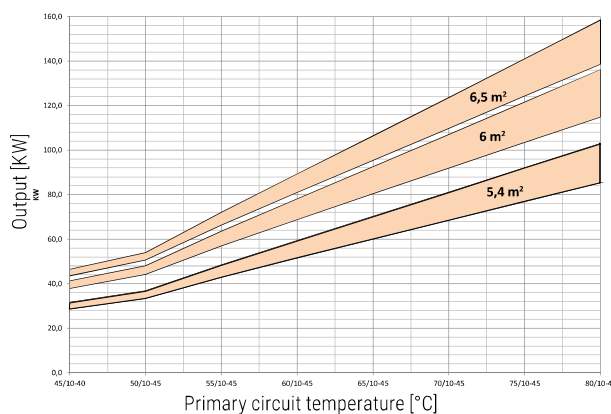
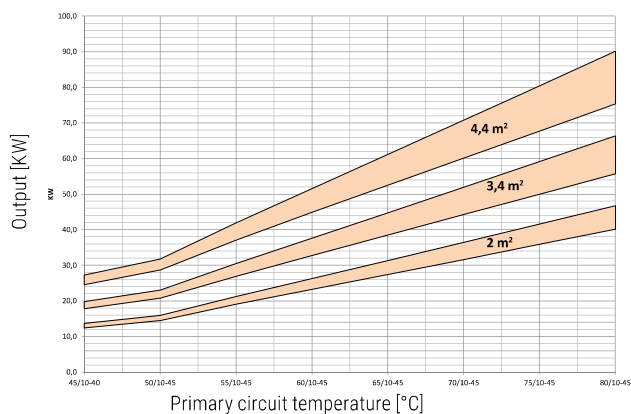

Heat exchanger surface	2 m ²		3,4 m ²		4,4 m ²	
	MAX	MIN	MAX	MIN	MAX	MIN
Flow rate [m ³ /h]	2,5	1,25	3	1,5	3,5	1,75

Heat exchanger surface	5,4 m ²		6 m ²		6,5 m ²	
	MAX	MIN	MAX	MIN	MAX	MIN
Flow rate [m ³ /h]	3,5	1,75	5	2,5	8	4

CALORIFIERS FOR HEAT PUMPS

EXAMPLE OF INSTALLATION WITH BOLLY® 1 XL

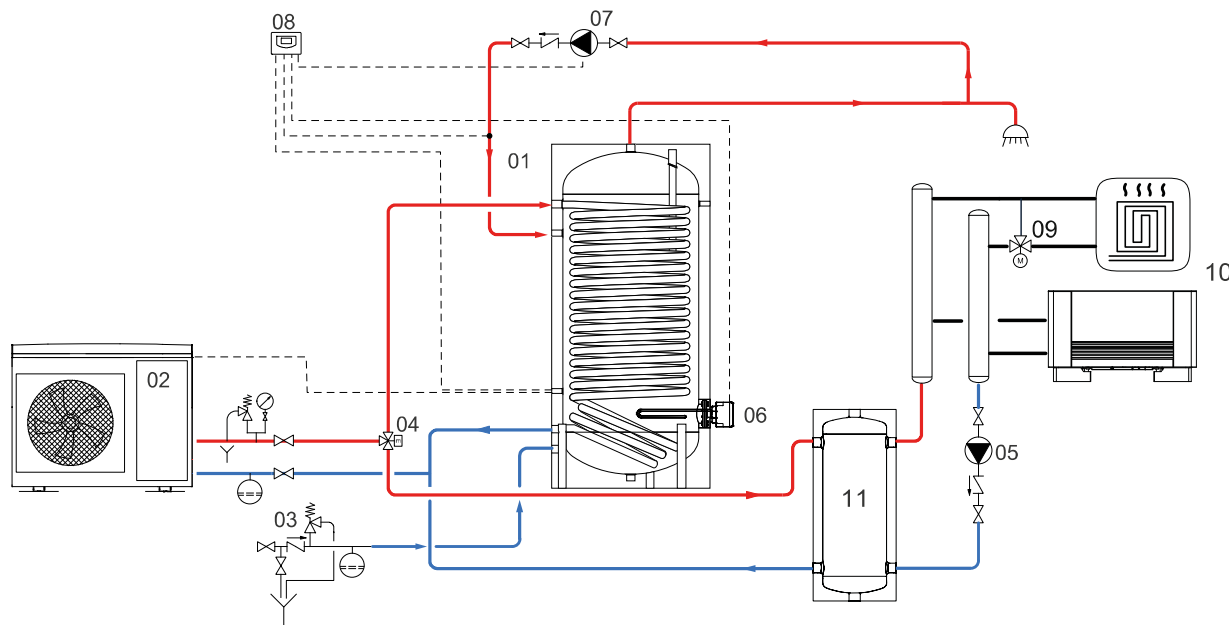

1 BOLLY® 1 XL	4 Motorized three-way valve	7 DHW recirculation	10 Heating units
2 Generator (Heat pump)	5 Circulation group for heating/cooling system	8 Electronic control /thermostat	11 Buffer tank
3 Hydraulic safety group	6 Electric immersion heater (optional)	9 Thermostatic mixing valve	

The following schemes are purely illustrative. To realize the installation, always refer to a qualified technician.