

# Serie B2.1



DOWNLOAD  
DATASHEET

Valvola a sfera flangiata in ghisa  
*Flanged ductile iron ball valve*



**b**-Smart, Be-Brandoni



**brandoni**  
VALVES

[www.brandonivalves.com](http://www.brandonivalves.com)

## Valvola a sfera flangiata in ghisa / Flanged ductile iron ball valve

Le valvole serie B2.1 sono valvole di intercettazione a sfera tipo split-body con corpo in ghisa sferoidale e sfera flottante, realizzate in accordo alle normative di prodotto rilevanti ed al sistema di gestione della qualità EN ISO 9001.

Sono adatte per riscaldamento e condizionamento (HVAC), teleriscaldamento, trattamento e distribuzione dell'acqua, applicazioni industriali, agricole, per aria compressa, gas, oli, idrocarburi e antincendio.

(Fatta salva la scelta corretta dell'articolo in base all'applicazione)

**Sono idonee:** per impieghi in linea e a fine linea e per servizio che richieda frequenti azionamenti; il supporto integrato in accordo a ISO 5211 permette il facile montaggio di una vasta gamma di servocomandi.

Le valvole a sfera serie B2 presentano un passaggio pieno e diritto che minimizza le turbolenze e le perdite di carico.

**Non sono idonee:** per vapore, per la parzializzazione e regolazione della portata.

### Accessori

- Prolunga per isolamento termico
- Cappuccio quadro per presa stradale
- Prolunga per presa stradale
- Kit flangia ISO 5211
- Kit Leva di manovra lucchettabile
- Kit interruttori di finecorsa per segnalazione Aperto/Chiuso

### Comandi

- Attuatori pneumatici a doppio e semplice effetto
- A richiesta: box finecorsa, posizionatore
- Attuatori elettrici
- Riduttori manuali

### Certificazioni / Certifications



Conformi alla Direttiva 2014/68/UE (ex 97/23/CE PED)  
Conformi alla Norma EN 13774, omologazione DVGW per gas n° N94313AM0052

Conformi alla norma AS4617:18, Type 1, omologazione AGA per gas n° 6633

Conformi al D.M. 174 (direttiva 98/83/CE), per utilizzo a contatto con acqua potabile.

**Norme costruttive e di collaudo** (equivalenti):

Scartamento: EN558/1 ISO 5752

Flange: EN1092 ISO 7005, ANSI B16.5 #150

Design: EN 1983, EN12516, ISO 5211

Marcatura EN19

Collaudo: testate al 100%, EN 12266 cat. A (ISO 5208 cat. A)

*Series B2.1 valves are shut-off ball valves split-body type in ductile iron and floating ball, manufactured according to the relevant product standards and the quality management relative to ISO 9001.*

*Suitable for heating and conditioning (HVAC), district heating, distribution and treatment of water, industrial application, agricultural application, for compressed air processing, for oils and hydrocarbon, for fire fighting.*

*(Please ensure the choice of the corresponding item)*

**YES:** *for installation in line and end of line, for services with frequent acting, the integrated ISO 5211 support allows the installation of a wide range of actuators.*

*The B2.1 range of ball valves are full and straight bore reducing turbulences and minimizing head loss.*

**NO:** *for steam, for choking and flow regulation.*

### Accessories

- Stem extension for thermal insulation
- Square cap for water main system connection
- Stem extension
- Kit ISO 5211 flange
- Kit lockable operation lever
- Kit limit switches for ON/OFF position indicator

### Actuators

- Double acting and single acting pneumatic actuators
- On request: limit switches, position indicator
- Electric actuators
- Gear box

*In conformity with directive 2014/68/UE (ex 97/23/CE PED)  
Conformity to EN 13774 norms, DVGW certification for gas n° N94313AM0052*

*Conformity to AS4617:18, Type 1, norms, AGA certification for gas n° 6633*

*Suitable for drinking water application, comply with Italian regulation D.M.174*

**Design and testing standards** (correspondences):

*Face-to-face: EN558/1 ISO 5752*

*Flanges: EN1092 ISO 7005, ANSI B16.5 #150*

*Design: EN 1983, EN12516, ISO 5211*

*Marking: EN19*

*Testing: 100% testing in accordance with EN 12266 cat. A (ISO 5208 cat. A)*



Verniciatura interna ed esterna con smalto epossidico, resistente alle alte temperature. Vernice a base acqua, a basso impatto ecologico.

*Inside and outside epoxy coating, high temperature resistant. Environmentally friendly, water-based paint.*

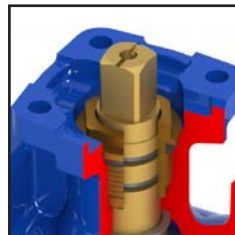

Flangia in accordo a ISO5211 integrata.

*Integrated flange, in accordance with ISO 5211.*



Doppia piastrina di fermo  
Sfilando una piastrina e ruotandola di 90° è possibile bloccare la leva in posizione aperta o chiusa.

*Twin stop plate  
Removing and repositioning of the plate at 90° allows locking of the valve in ON-OFF position.*

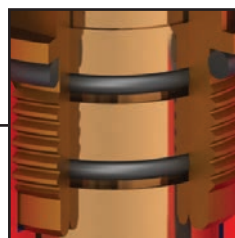

Il doppio O-Ring sullo stelo e la busola metallica garantiscono la tenuta dinamica anche nelle condizioni più gravose.

*The dynamic seal of the stem is guaranteed by a double O-ring, even in severe working conditions.*

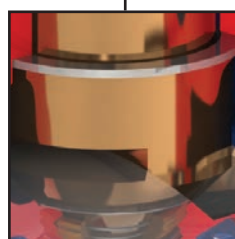

Stelo con design antiespulsione.  
*Blow-out proof stem.*

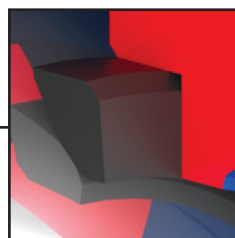

Sede sfera in PTFE caricato, al variare della temperatura la coppia di manovra rimane costante.

*Seat of ball in reinforced PTFE, as temperature changes, the torque remains constant.*

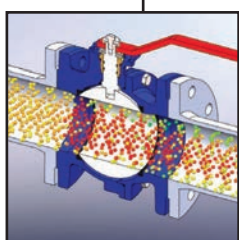

Sfera a passaggio pieno e cilindrico, in ottone cromato o in acciaio inox.

*Ball with full and straight bore, in chromed brass or stainless steel.*

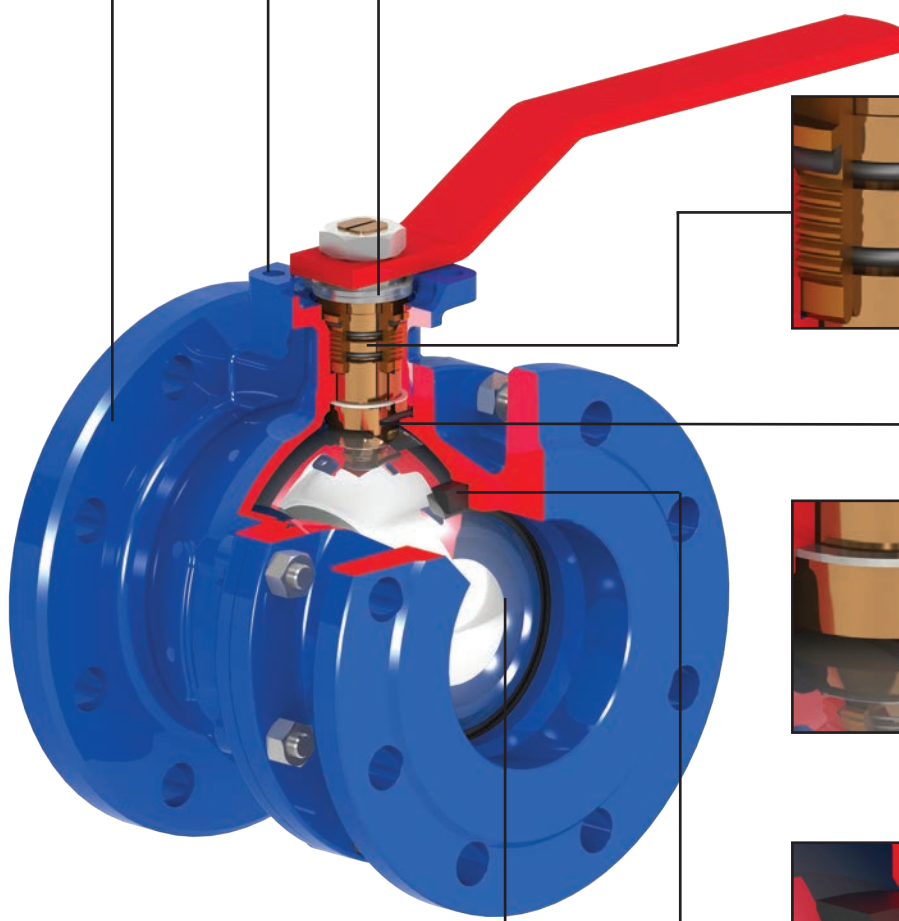

### O-Ring in NBR



#### B2.100

Corpo: Ghisa sferoidale  
Sfera: Ottone  
Asta: Ottone  
O-ring: NBR  
Temp: da -10 a +100°C

Body: Ductile iron  
Ball: Brass  
Stem: Brass  
O-ring: NBR  
Temp: -10 +100°C



#### B2.110

Corpo: Ghisa sferoidale  
Sfera: AISI 304  
Asta: Ottone  
O-ring: NBR  
Temp: da -10 a +100°C

Body: Ductile iron  
Ball: AISI 304  
Stem: Brass  
O-ring: NBR  
Temp: -10 +100°C



#### B2.111

Corpo: Ghisa sferoidale  
Sfera: AISI 304  
Asta: AISI 304  
O-ring: NBR  
Temp: da -10 a +100°C

Body: Ductile iron  
Ball: AISI 304  
Stem: AISI 304  
O-ring: NBR  
Temp: -10 +100°C



#### B2.121

Corpo: Ghisa sferoidale  
Sfera: AISI 316  
Asta: AISI 304  
O-ring: NBR  
Temp: da -10 a +100°C

Body: Ductile iron  
Ball: AISI 316  
Stem: AISI 304  
O-ring: NBR  
Temp: -10 +100°C

Per DN 200 - 250 / For DN 200 - 250

#### B2.000

Corpo: Ghisa grigia  
Body: Cast iron

#### B2.010

Corpo: Ghisa grigia  
Body: Cast iron

#### B2.011

Corpo: Ghisa grigia  
Body: Cast iron

#### B2.021

Corpo: Ghisa grigia  
Body: Cast iron

Scartamento EN 558/1-29 (ex NF 29-323) / Face to face EN 558/1-29 (ex NF 29-323)

#### F2.100

Vedi B2.100  
See: B2.100

#### F2.110

Vedi B2.110  
See: B2.110

#### F2.111

Vedi B2.111  
See: B2.111

#### F2.121

Vedi B2.121  
See: B2.121

### Per Gas / For Gas



#### B2.100 gas

Corpo: Ghisa sferoidale  
Sfera: Ottone  
Asta: Ottone  
O-ring: NBR  
Temp: da -10 a +70°C

Body: Ductile iron  
Ball: Brass  
Stem: Brass  
O-ring: NBR  
Temp: -10 +70°C



Appr. n°  
N94313AM0052  
Appr. n 6633,  
Type 1  
AS4617:18



#### B2.110 gas

Corpo: Ghisa sferoidale  
Sfera: AISI 304  
Asta: Ottone  
O-ring: NBR  
Temp: da -10 a +70°C

Body: Ductile iron  
Ball: AISI 304  
Stem: Brass  
O-ring: NBR  
Temp: -10 +70°C



#### B2.111 gas

Corpo: Ghisa sferoidale  
Sfera: AISI 304  
Asta: AISI 304  
O-ring: NBR  
Temp: da -10 a +70°C

Body: Ductile iron  
Ball: AISI 304  
Stem: AISI 304  
O-ring: NBR  
Temp: -10 +70°C



#### B2.121 gas

Corpo: Ghisa sferoidale  
Sfera: AISI 316  
Asta: AISI 304  
O-ring: NBR  
Temp: da -10 a +70°C

Body: Ductile iron  
Ball: AISI 316  
Stem: AISI 304  
O-ring: NBR  
Temp: -10 +70°C

## O-Ring in FKM



### B2.100 FKM \*

Corpo: Ghisa sferoidale  
Sfera: Ottone  
Asta: Ottone  
O-ring: FKM  
Temp: da -10 a +150°C

*Body: Ductile iron  
Ball: Brass  
Stem: Brass  
O-ring: FKM  
Temp: -10 +150°C*



### B2.110 FKM \*

Corpo: Ghisa sferoidale  
Sfera: AISI 304  
Asta: Ottone  
O-ring: FKM  
Temp: da -10 a +150°C

*Body: Ductile iron  
Ball: AISI 304  
Stem: Brass  
O-ring: FKM  
Temp: -10 +150°C*



### B2.111 FKM \*

Corpo: Ghisa sferoidale  
Sfera: AISI 304  
Asta: AISI 304  
O-ring: FKM  
Temp: da -10 a +150°C

*Body: Ductile iron  
Ball: AISI 304  
Stem: AISI 304  
O-ring: FKM  
Temp: -10 +150°C*



### B2.121 FKM \*

Corpo: Ghisa sferoidale  
Sfera: AISI 316  
Asta: AISI 304  
O-ring: FKM  
Temp: da -10 a +150°C

*Body: Ductile iron  
Ball: AISI 316  
Stem: AISI 304  
O-ring: FKM  
Temp: -10 +150°C*

**\* Particolarmente indicate per Teleriscaldamento per acqua fino a 150°C**

**\* Most suitable for district heating for water up to 150 °C**

Verniciatura: rivestimento epossidico interno ed esterno colore RAL 5002

Coating: inside and outside epoxy coated RAL 5002 colour

I componenti ed accessori realizzati in acciaio NON inox, anche se protetti da verniciatura, zincatura o altro trattamento, se utilizzati in ambienti all'aperto, in condizioni di forte umidità/condensa od in ambienti aggressivi, possono mostrare una durata di protezione all'ossidazione limitata nel tempo.

Components and accessories made in steel different from stainless steel, even if protected by painting or galvanizing, if used in outdoor environments, in conditions of high humidity / condensation or in aggressive environments, may exhibit a limited protection span against oxidation.



#### B2.1 + RM

Riduttore manuale  
Gear box

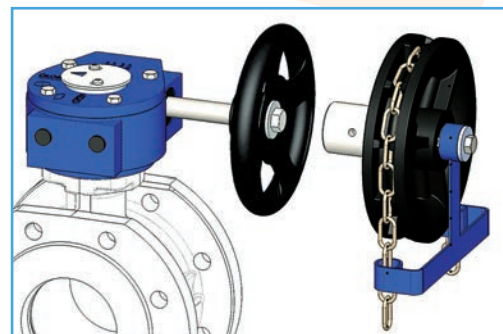
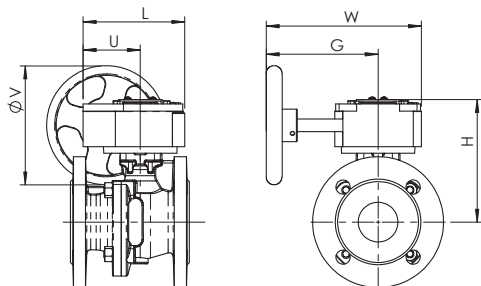

#### KCAT

Kit comando a catena  
Chain driver kit

DN	15	20	25	32	40	50	65	80	100	125	150	200	250
B2 + RM	RM.0250	RM.0250	RM.0250	RM.0250	RM.0250	RM.0250	RM.0250	RM.0250	RM.0250	RM.0750	RM.0750	RM.1200	RM.1200
L	130	130	130	130	130	130	130	130	130	180	180	205	256
U	77	77	77	77	77	77	77	77	77	104	104	124	101
H	112.5	114	121	126	140.5	149	157	180	194.5	243	260.5	310	448
W	225	225	225	225	225	225	225	225	225	338	338	345	464
G	170	170	170	170	170	170	170	170	170	260	260	260	360
V	150	150	150	150	150	150	150	150	150	300	300	300	500
Peso / Weight Kg	6.9	7.6	8.5	10.1	11.8	13.3	14.8	19.8	22.8	38.3	48.8	105.3	192.3



#### B2.1 + AOX

Attuatori elettrici  
Electric actuators

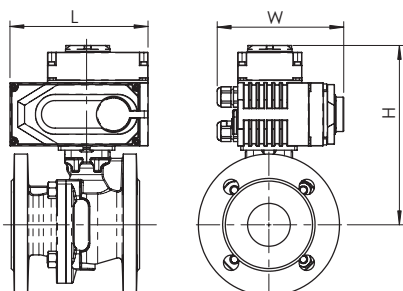

DN	15	20	25	32	40	50	65	80	100	125	150	200
B2 + AOX	003	003	003	003	005	005	008	015	015	030	040	100
L	123	123	123	123	160	160	160	189	189	268	268	268
H	164	165	172	177	200	208	216	247	262	329	347	394
W	100	100	100	100	121	121	121	145	145	225	225	225
Peso / Weight Kg	4.7	5.4	6.3	7.9	11.1	12.6	14.1	20.1	23.1	41.4	52.3	107.5



#### B2.1 + AP

Attuatori pneumatici  
Pneumatic actuator

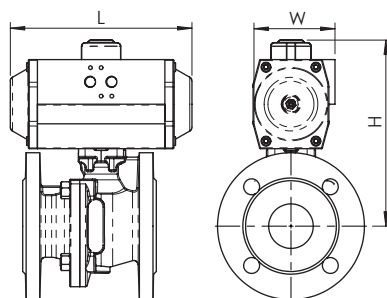

DN	15	20	25	32	40	50	65	80	100	125	150	200	250
B2 + AP DE - DA	AP052	AP052	AP052	AP063	AP063	AP063	AP075	AP092	AP105	AP125	AP140	AP190	AP270
L	147	147	147	165	165	165	182	262	270	298	395	528	721
H	182.5	184	191	212	186.5	195	215	255	285.5	329	374.5	570	793
W	72	72	72	83	83	83	95	109	125	134	153	206	294
Peso / Weight Kg	3.8	4.5	5.4	7.8	9.5	11	13.1	20.1	24.5	36.7	52.5	126.2	258.7
B2 + AP SE - SPRING RETURN	AP075S	AP075S	AP075S	AP075S	AP083S	AP083S	AP092S	AP125S	AP140S	AP160S	AP190S	AP270S	AP400S
L	182	182	182	182	208	208	262	298	395	454	528	721	925
H	210.5	212	219	224	207.5	216	232	282	384.5	382	522.5	668	821
W	95	95	95	95	103	103	109	134	153	174	206	294	516
Peso / Weight Kg	5.46	6.16	7.06	8.66	11.1	12.6	15.9	25.5	35	52.4	78.7	193	465

## Comandi e accessori / Actuators and accessories

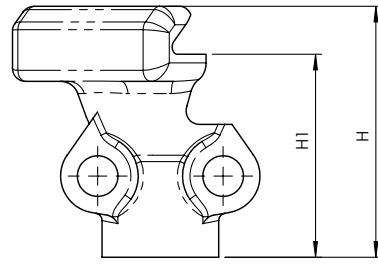
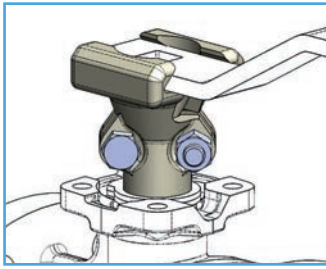

DN	25-32-40-50-65	80-100-125-150
H	68	68
H1	55	55

### KITB2

Prolunga per isolamento termico / Stem extension for thermal insulation

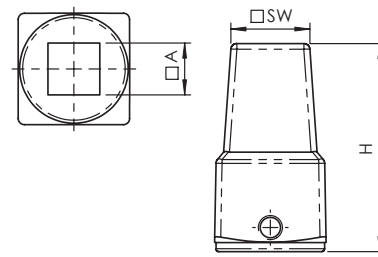
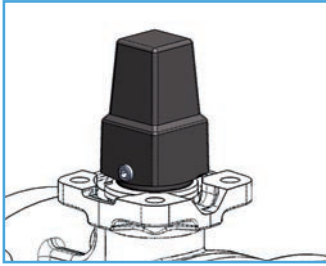

DN	40-50-65	80-100	125-150
SW	26	26	26
A	14	17	22
H	69	69	71

### KCAPB2

Cappuccio quadro per presa stradale / Square cap for water main system connection

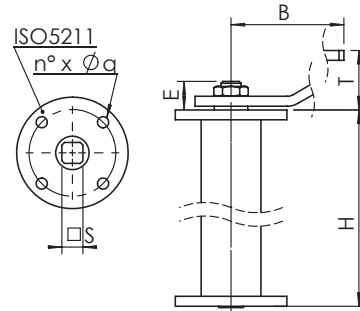
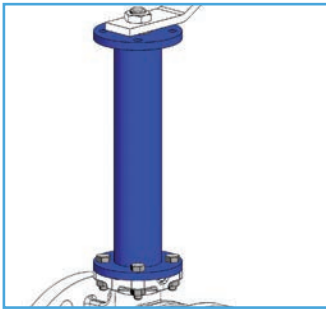

DN	40	50	65	80	100	125	150
H	250-500-800-1000						
T	48	48	48	48	48	59	59
B	230	230	230	280	360	450	560
ISO 5211	F05	F05	F05	F07	F07	F10	F10
J	50	50	50	70	70	102	102
n° x Ø q	4x7	4x7	4x7	4x9	4x9	4x11	4x11
E	22	22	22	23	23	27	27
S	14	14	14	17	17	22	22

### KPRB

Prolunga per presa stradale / Stem extension for water main system connection

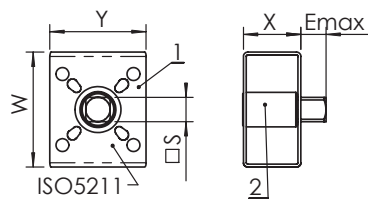
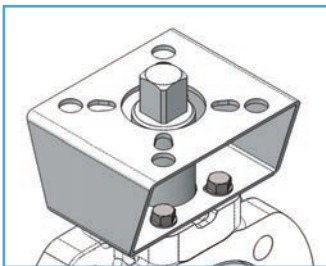

- 1) Flangia / Bracket
- 2) Giunto / Joint

### KISO.B2

Kit flangia ISO 5211 / Kit ISO 5211 flange

DN	15-20	25-32	40-50-65	80	100	125	150
ISO 5211*	F04-05-07	F04-05-07	F05-07	F10-12	F10-12	F10-12	F10-12-14
S x E	14 x 14	17 x 17	17 x 17	22 x 22	27 X 27	27 X 27	36 X 36
Foratura lato valvola Drilling valve side	F03-04	F03-04	F05-07	F07-10	F07-10	F07-10	F10-12-14
X	40	40	50	60	60	60	80
Y	70	70	70	120	120	120	140
W	80	80	100	120	120	120	160

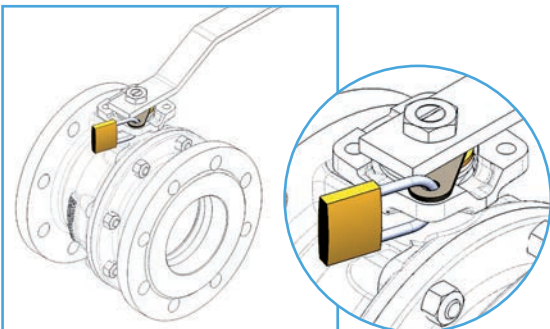

Kit leva di manovra lucchettabile  
Kit lockable operation lever

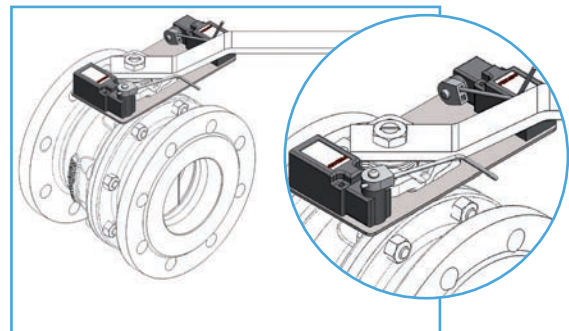

### KFC

Kit interruttori di finecorsa per segnalazione Aperto/Chiuso  
Kit limit switches for ON/OFF position indicator

### B2.1 - DN 15- 150

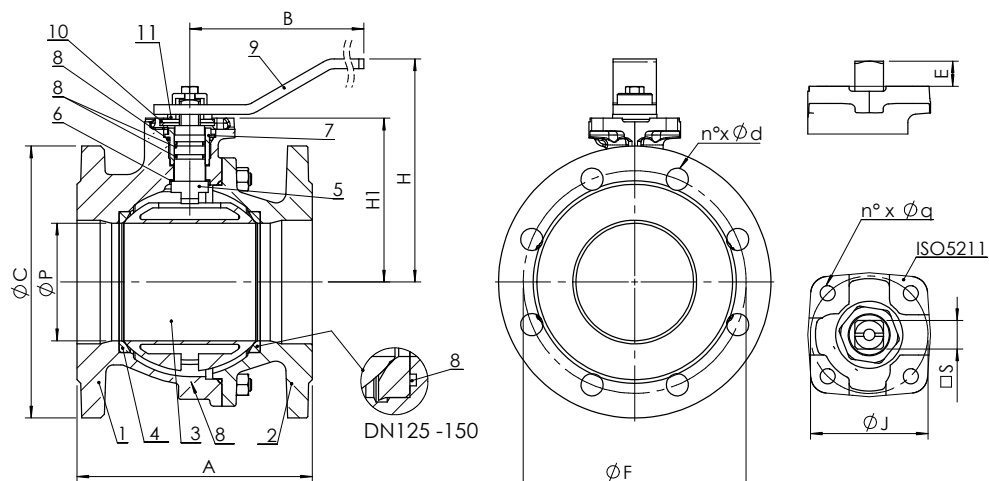

### B2.0/B2.1 - DN 200

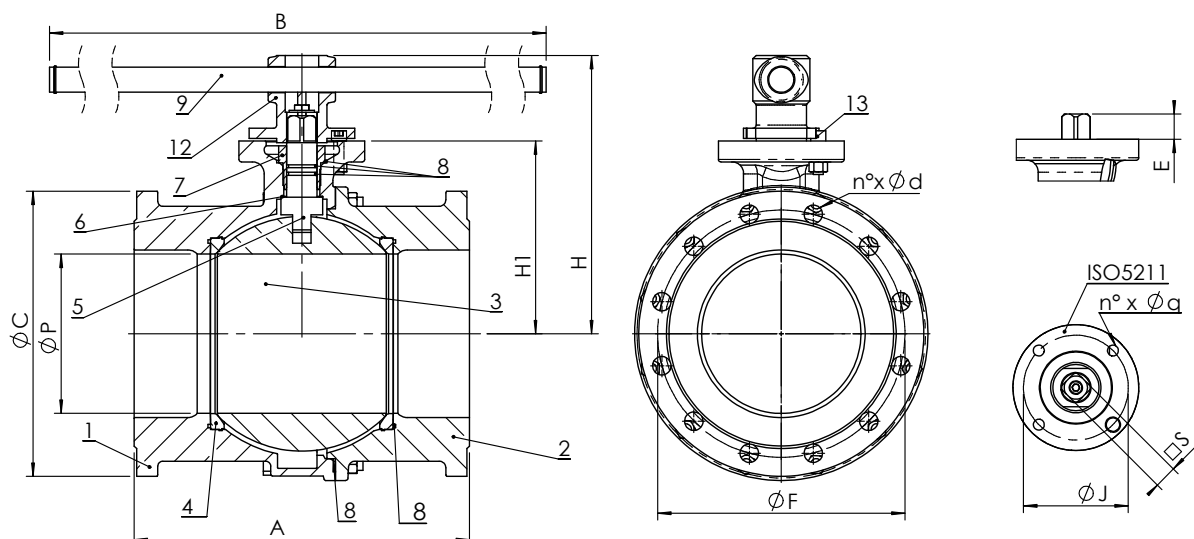

### B2.0 - DN 250

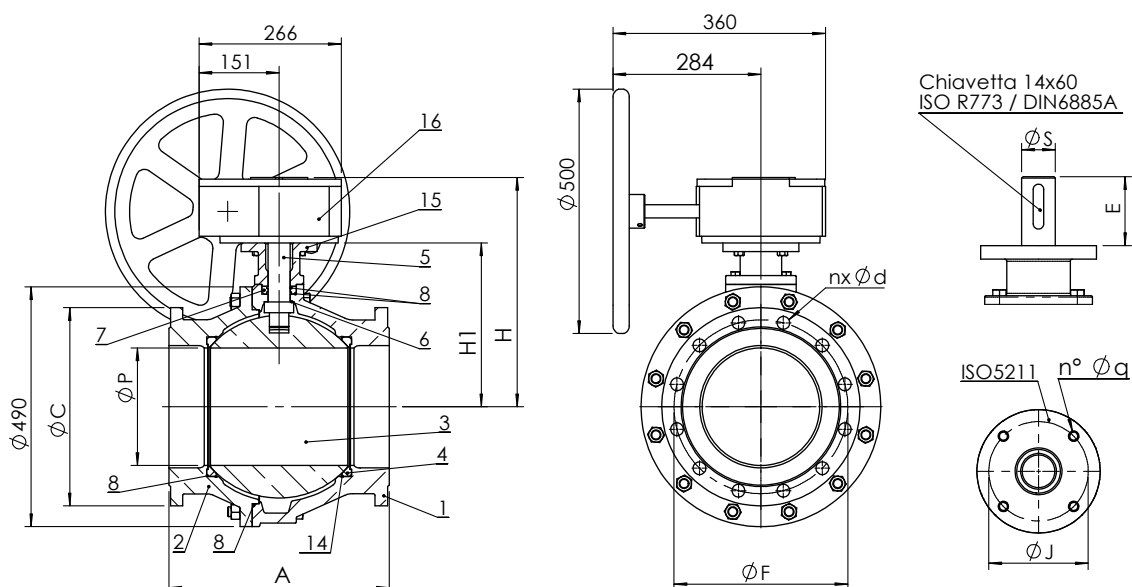



## Dimensioni (mm) / Dimensions (mm)

DN		15	20	25	32	40	50	65	80	100	125	150	200	250***	
P		15	20	25	32	40	50	63	76	95	120	145	190	240	
A (B2.1)	EN 558/1 - 14 (ex DIN 3202 F4)	115	120	125	130	140	150	170	180	190	200	210	-	-	
A (B2.0)	EN 558/1 - 14 (ex DIN 3202 F5)	-	-	-	-	-	-	-	-	-	-	-	400	450	
A (F2.1)	EN 558/1 - 29 (ex NF 29-323)	-	-	-	-	136	142	154	160	172	186	200	-	-	
H		84	84	96	101	125	135	143	165	180	225	243	320	448	
H1		50,5	52	59	64	78,5	87	95	118	132,5	165	182,5	230	335	
B		160	160	170	170	230	230	230	280	360	520	520	1'000	-	
C		95	105	115	140	150	165	185	200	220	250	285	340	405	
F	EN1092/2 PN 16	65	75	85	100	110	125	145	160	180	210	240	295	355	
n x d		4 x 14	4 x 14	4 x 14	4 x 18	4 x 18	4 x 18	4 x 18	8 x 18	8 x 18	8 x 18	8 x 22	12 x 22	12 x 26	
ISO 5211		F04	F04	F04	F04	F05	F05	F05	F07	F07	F10	F10	F12	F12	
J		42	42	42	42	50	50	50	70	70	102	102	125	125	
n' x Øq		4 x 6	4 x 6	4 x 6	4 x 6	4 x 7	4 x 7	4 x 7	4 x 9	4 x 9	4 x 11	4 x 11	4 x 13	4 x 13	
E		9,5	9,5	11	11	13,5	13,5	15	15	15	21	21	27	77	
S		□ 9	□ 9	□ 11	□ 11	□ 14	□ 14	□ 14	□ 14	□ 17	□ 17	□ 22	□ 22	□ 27	Ø 45

## Peso (kg) / Weight (kg)

DN		15	20	25	32	40	50	65	80	100	125	150	200	250
B2.100		2,6	3,3	4,2	5,8	7,5	9	10,5	15,5	18,5	28	38,5	-	-
B2.110 - B2.111 - B2.121		2,6	3,3	4,2	5,8	7,8	9,7	12,2	16,7	22,2	35,8	46,6	-	-
B2.000 - B2.040		-	-	-	-	-	-	-	-	-	-	-	93	180
B2.010 - B2.011 - B2.021		-	-	-	-	-	-	-	-	-	-	-	117	180

## Coppia di manovra (Nm) / Operating torque (Nm)

DN		15	20	25	32	40	50	65	80	100	125	150	200	250
Nm		15	15	18	18	18	20	40	70	100	180	250	600	2'000

N.B. al fine di ottimizzare la scelta del servocomando si consiglia di moltiplicare il momento torcente per il coefficiente di sicurezza K=1,5  
 N.B.: In order to choose the right actuator, we recommend multiplying the operating torque figure by a safety coefficient, K=1.5

### Materiali / Materials

	Componente - Component	Materiale - Material	
		Serie B2.1	Serie B2.0
1	Corpo - Body	Ghisa sferoidale / Ductile iron EN GJS 400-15	Ghisa grigia / Cast iron EN GJL250
2	Flangia - Flange	Ghisa sferoidale / Ductile iron EN GJS 400-15	Ghisa grigia / Cast iron EN GJL250
3	Sfera - Ball	Ottone / Brass CuZn40Pb2 Acciaio inossidabile / Stainless steel AISI 304 Acciaio inossidabile / Stainless steel AISI 316	DN200 Ottone cromato / Brass chrome plated CuZn40Pb2 DN250 Ghisa grigia riv. Niploy / Cast iron EN GJL250 Niploy coated Acciaio inossidabile / Stainless steel AISI 304 Acciaio inossidabile / Stainless steel AISI 316
4	Sede sfera - Ball seat	PTFE + Carbone / Carbon reinforced PTFE	
5	Asta - Stem	Ottone cromato / Brass chrome plated CuZn40Pb2 Acciaio inossidabile Stainless steel AISI 304 Acciaio inossidabile Stainless steel AISI 316	
6	Anello antifrizione - Sliding Ring	PTFE	
7	Ghiera - Ring nut	Ottone cromato / Brass chrome plated CuZn40Pb2 Acciaio inossidabile Stainless steel AISI 304 Acciaio inossidabile Stainless steel AISI 316	
8	O Ring	NBR / FKM (Viton®)	
9	Leva - Handle	Acciaio al carbonio, verniciato epossidico / Carbon steel epoxy coated	
10	Piastrina fermo - Stop plate	Acciaio al carbonio zincato / Carbon steel galvanized	
11	Anello elastico - Spring washer	Acciaio al carbonio zincato / Carbon steel galvanized	
12	Mozzo leva - Handle support	Ghisa sferoidale / Ductile iron EN GJS 400-15	
13	Fermo leva - Handle stop	Acciaio al carbonio zincato / Carbon steel galvanized	
14	Anello antiestrazione - Retaining ring	AISI302	
15	Supporto per riduttore - Gear box bearing	DN200 Ghisa sferoidale / Ductile iron EN GJS 400-15 EN GJS 400-15 DN250 Ghisa grigia / Cast iron EN GJL250	
16	Riduttore manuale - Gear box	-	
17	Bulloneria - Nuts and bolts	Acciaio al carbonio zincato / Carbon steel galvanized	

### Foratura / Drilling

DN		15	20	25	32	40	50	65	80	100	125	150	200	250
Dim. flangia in accordo PN 16 EN1092/2 Dimensions of flanges according to PN 16 EN1092/2	Foratura PN 16 EN1092/2 Drilling PN 16 EN1092/2	std	std	std	std	std	std	std	std	std	std	std	std	std
	Foratura PN 10 EN1092/2 Drilling PN 10 EN1092/2	=	=	=	=	=	=	=	=	=	=	=	opt	opt
	Foratura PN 6 EN1092/2 Drilling PN 6 EN1092/2	opt	opt	opt	opt	opt	opt	opt	opt	opt	opt	opt	opt	opt
	Foratura PN 25 EN1092/2 Drilling PN 25 EN1092/2	=	=	=	=	=	=	=	opt	=	no	no	no	no
	Foratura ANSI B16.5 #150 Drilling ANSI B16.5 #150	opt	opt	opt	opt	opt	opt	opt	opt	opt	opt	opt	opt	opt

std: standard / opt: opzionale a richiesta / =: uguale a PN16 / std: standard / opt: option on request / =: same as PN16  
NB: altre forature a richiesta / other drillings on request

## Pressione massima / Maximum pressure

Tipo fluido * Fluids *	Montaggio Mounting	
	TRA FLANGE BETWEEN FLANGES	FINE LINEA END OF LINE
Gas pericolosi G1 Hazardous gases G1	16 bar DN15-200 10 bar DN250	10 bar DN15-100 NO DN125-250
Liquidi pericolosi L1 Hazardous liquids L1	16 bar DN15-200 10 bar DN250	10 bar
Gas non pericolosi G2 Non hazardous gases G2	16 bar DN15-200 10 bar DN250	10 bar
Liquidi non pericolosi G2 Non hazardous liquids G2	16 bar	10 bar
Acqua** Water**	16 bar	16 bar

\* gas, liquidi pericolosi secondo 2014/68/EU e 1272/2008 (CLP)

\*\* Per la raccolta, distribuzione e deflusso di acqua (PED 2014/68/EU 1.1.2b)

\* hazardous gas, liquids acc. 2014/68/EU e 1272/2008 (CLP)

\*\* For supply, distribution and discharge of water (PED 2014/68/EU 1.1.2b)

## Temperatura / Temperature

Temperatura - Temperature	min °C	max °C - Max °C	
		continuo continuous	picco peak
NBR	-10	100	110
FKM (Viton®)	-10	150	170

Attenzione: la pressione massima di utilizzo diminuisce con la temperatura, vedi diagramma "Pressione/Temperatura"

NB: the maximum working pressure decreases while temperature increases, please refer to "pressure/temperature" chart

## Diagramma Pressione/Temperatura - Pressure/temperature chart

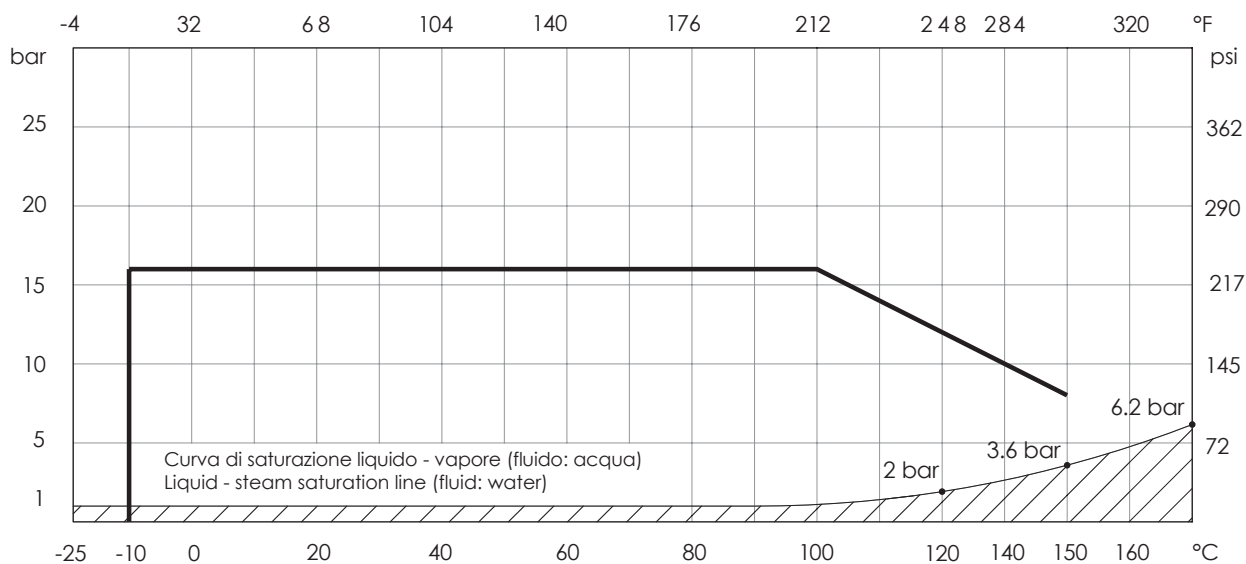

NON ADATTA PER VAPORE. NON utilizzare in condizioni di temperature e pressione al di sotto della curva di saturazione liquido-vapore (area tratteggiata)  
RANGE NOT SUITABLE FOR STEAM. DO NOT use when temperature and pressure are below the liquid-steam saturation line (hatched area)



### Perdite di carico Fluido: acqua (1m H<sub>2</sub>O = 0,098bar) / Head loss Fluid: water (1m H<sub>2</sub>O = 0,098bar)

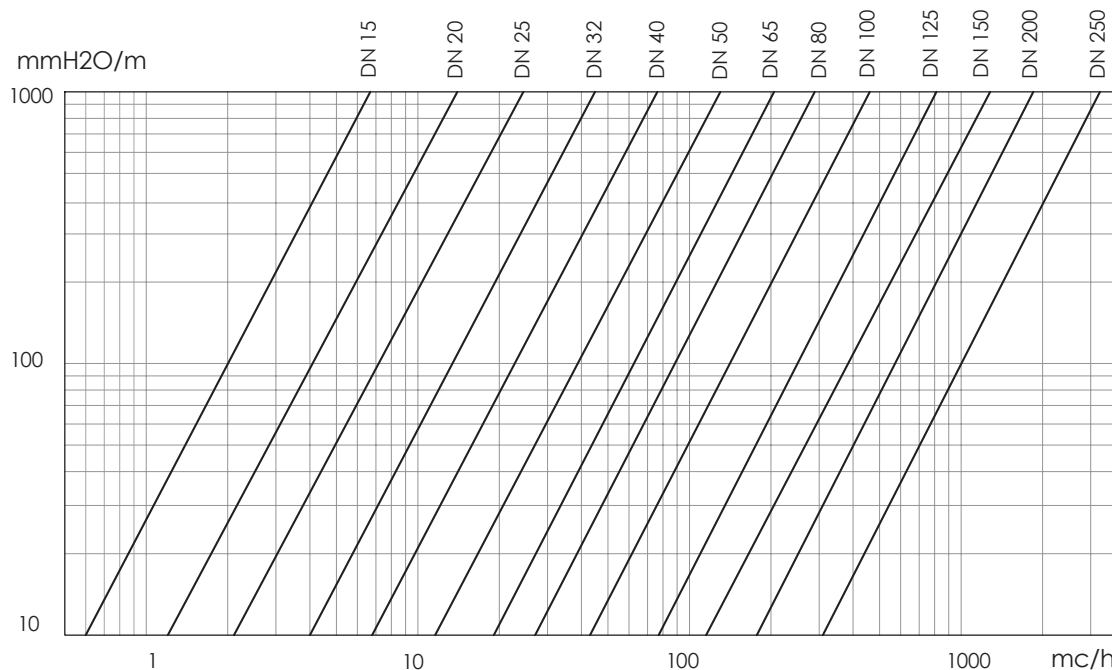

### Tabella Kv - DN / Kv - DN chart

DN	15	20	25	32	40	50	65	80	100	125	150	200	250
Kv	22.3	47.7	83.5	150.4	255	435	672	947	1'508	2'633	4'261	5'957	10'510

I dati e le caratteristiche di questo catalogo sono forniti a titolo indicativo. La Brandoni S.p.A. si riserva di modificare una o più caratteristiche delle valvole senza preavviso. Per maggiori informazioni [www.brandonivalves.com](http://www.brandonivalves.com).

Brandoni SpA reserves the right to make changes in design and/or construction of the products at any time without prior notice. For further information, please refer to [www.brandonivalves.com](http://www.brandonivalves.com)