

INDIRECTLY HEATED WATER TANKS FOR HEAT PUMP SYSTEMS



Indirectly heated water tanks for Heat Pump systems with models ranging from 160l to 1000l with high-output heat exchanger/s.

- Big enough surface of heat exchangers for heat pump and condensing gas boiler systems.
- Suitable to work with low temperature heat carrier.
- Include models with two double coil heat exchangers (lower solar heat exchanger).
- Decreased hydraulic resistance (pressure drop) of the heat exchanger with bigger diameter of the inlet and outlet on 1.1/2".
- Crystal Tech PRO – High-quality¹ enameled coating for longer life of the water tank².
- 2 magnesium anodes protecting the enamel coating of the whole inner surface of the tank in a proper way.
- High efficiency PU insulation.
- Energy efficiency class B o C, depending on the model.

¹Enamel coating according to DIN 4753-3: 2017, clauses: 6.4.3 (acid resistance), 6.5 (hygiene safety), 6.6 (stability);

²When used correctly according to the manufacturer's instructions. Life expectancy may vary according to natural and other external factors beyond the control of the manufacturer

TECHNICAL DATA I Models with one double coil

TYPE		EV 2x10 S 160 60 HP	EV 2x12 S 200 60 HP	EV 2x15 S 200 60 HP	EV 2x15 S 300 65 HP	EV 2x19 S 300 65 HP	EV 2x19 S 400 75 HP	EV 2x23 S 500 75 HP	EV 2x14 S 800 95 HP DN18	EV 2x17 S 1000 101 HP DN18
Art.number	Nº	304703	305251	305250	305257	305256	305248	305231	305407	305415
Capacity	L	149	186	183	271	267	369	451	770	937
Net weight	kg	65	89	102	106	130	162	183	254	297
Insulation (rigid PU)	mm	50	50	50	50	50	50	50	50	50
Heat exchanger surface S1	m²	1.7	2.1	2.56	3	3.84	5.05	6	3.8	4.5
Heat exchanger capacity S1	L	11	12.5	15.6	18.3	23	31	33	17.2	27.1
Heat losses ΔT_{45K}	W	1.2	1.4	1.4	1.6	1.6	2.2	2.3	3.1	3.4
Energy efficiency class		B	B	B	B	B	B	C	C	C
Maximum operational temperature	°C	95	95	95	95	95	95	95	95	95
Maximum operational temperature of heat exchanger	°C	110	110	110	110	110	110	110	110	110
Rated pressure	bar	8	8	8	8	8	8	8	8	8
Rated pressure of the heat exchanger	bar	6	6	6	6	6	6	6	6	6
Heat exchanger reheat performance P at flow rate of primary side (S1) Coil 80°	kW/(l/min)	27.8[16.6]/ 36.5[33.3]	33.4[20.8]/ 46.3[41.7]	39.0[20.8]/ 55.2[41.7]	45.8[25.0]/ 64.8[50.0]	52.3[25.0]/ 73[50.0]	66.7[29.2]/ 101.7[58.3]	76.7[29.2]/ 117.2[58.3]	66.9[50]/ 85.4[100]	78[50]/ 104[100]
V40 -hot water delivered with a temperature of at least 40 °C (S1) Coil 80°	L	205	327	299	450.5	357.4	567	662.3	1283	1435
Reheat time 10-60°C rate at primary side (S1) Coil 80°	min/(l/min)	15.46 / 16.6 / [12.50 / 33.3]	18.3/20.8 [13.5/41.7]	14.66/20.8 [10.7/41.7]	18.3/25, [13.2/50]	14.7/25, [10.88/50]	16.01/29.2, [10.8/58.3]	16.8/29.2 [11.7/58.3]	38.06/50 [29.78/100]	37.38/50 [28.36/100]
Heat exchanger reheat performance P at flow rate of primary side (S1) Coil 55°	kW/(l/min)	27.8/[36.5]	30.2[33.3]/ 45.4[50.0]	39.0[33.3]/ 55.2[50.0]	45.8[33.3]/ 64.8[50.0]	54.6[33.3]/ 71.2[50.0]	31.5[33.3]/ 37.1[50.0]	29.6[33.3]/ 35.7[50.0]	21.3[33.3]/ 26[50]	24.9[33.3]/ 30.3[50]
V40 -hot water delivered with a temperature of at least 40 °C (S1) Coil 55°	L	205.5	262	240	383	340	468	500	1033	1128
Reheat time 10-50°C rate at primary side (S1) Coil 55°	min/(l/min)	15.46 / 16.6 / [12.50 / 33.3]	29.81/33.3 [25.81/50]	22.66/33.3 [20.25/50]	33.05 / 33.3 [27.68/50]	27.91 / 33.3 [23.73/50]	27.41 / 33.3 [23.18/50]	35.61/33.3 [30.0/50]	93.08/33.3 [78.95/50]	91.05/33.3 [74.7/50]
Coil Pressure drop at flow rate m³/h (S1)	mBar/(l/min)	6.4[16.6]/ 30[33.3]	13.9[20.8]/ 53.3[41.7]	13.0[20.8]/ 56.6[41.7]	18.9[20.8]/ 79.1[41.7]	21.5[25.0]/ 94.9[50.0]	42.6[29.2]/ 171.5[58.3]	45.9[29.2]/ 173.2[58.3]	195.6[50]/ 666.2[100]	199.4[50]/ 675.8[100]
Performance index NL without additional heating S1	-	1.5	3.6	3.6	8.2	5.6	14.3	17.6	53.5	66

DRAWINGS, CONNECTIONS AND DIMENSIONS

Models with one double coil

		EV 2x10 S 160 60 HP	EV 2x12 S 200 60 HP	EV 2x15 S 200 60 HP	EV 2x15 S 300 65 HP	EV 2x19 S 300 65 HP	EV 2x19 S 400 75 HP	EV 2x23 S 500 75 HP	EV 2x14 S 800 95 HP DN18	EV 2x17 S 1000 101 HP DN18
A	mm	791	995	996	1184	1184	1168	1447	1591	1625
C	mm	271	264	264	278	278	272	405	360	374
D	mm	791	996	996	1184	1184	1171	1447	1779	1845
F	mm	712	792	794	1055	953	1059	1162	1272	1347
H	mm	1007	1202	1197	1420	1420	1400	1670	1974	2012
I	mm	602	897	919	937	1120	1118	1378	971	1115
J	mm	207	202	202	205	206	225	225	309	324
K	mm	207	202	202	205	206	225	225	81	81
L	mm	699	897	897	1055	1055	1059	1162		
M	mm	499	633	633	691	691	778	864	1005	919
N	mm	289	360	360	398	398	448	467	575	470
R	mm	1169	1345	1345	1560	1560	1590	1823	2014	2100
ØC	mm	600	600	600	650	650	750	750	950	1010
ØD	mm	500	500	500	550	550	650	650	790	850

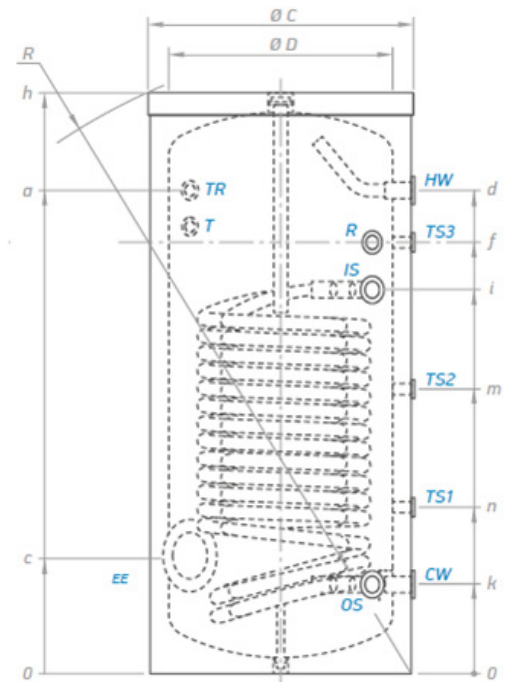

		EV 2x10 S 160 60 HP	EV 2x12 S 200 60 HP	EV 2x15 S 200 60 HP	EV 2x15 S 300 65 HP	EV 2x19 S 300 65 HP	EV 2x19 S 400 75 HP	EV 2x23 S 500 75 HP	EV 2x14 S 800 95 HP DN18	EV 2x17 S 1000 101 C HP DN18
CW	cold water inlet	G 1"	G 1"	G 1"	G 1"	G 1"	G 1"	G 1"	G 1½"	G 1½"
HW	hot water outlet	G 1"	G 1"	G 1"	G 1"	G 1"	G 1"	G 1"	G 1½"	G 1½"
IS1	heat exchanger inlet	G 1"	G 1½"	G 1½"	G 1½"	G 1½"	G 1½"	G 1½"	G 1½"	G 1½"
IS2	heat exchanger inlet								G 1½"	G 1½"
OS1	heat exchanger outlet	G 1"	G 1½"	G 1½"	G 1½"	G 1½"	G 1½"	G 1½"	G 1½"	G 1½"
OS2	heat exchanger outlet								G 1½"	G 1½"
R	recirculation	G ¾"	G ¾"	G ¾"	G ¾"	G ¾"	G ¾"	G ¾"	G ¾"	G ¾"
T	thermometer	Ø14x1.5	Ø14x1.5	Ø14x1.5	Ø14x1.5	Ø14x1.5	Ø14x1.5	Ø14x1.5	Ø14x1.5	Ø14x1.5
TR	opening for thermoregulator	G ½"	G ½"	G ½"	G ½"	G ½"	G ½"	G ½"	G ½"	G ½"
TS1	thermo pocket level 1	G ½"	G ½"	G ½"	G ½"	G ½"	G ½"	G ½"	G ½"	G ½"
TS2	thermo pocket level 2	G ½"	G ½"	G ½"	G ½"	G ½"	G ½"	G ½"	G ½"	G ½"
EE	opening for electric element	G 1½"	G 1½"	G 1½"	G 1½"	G 1½"	G 1½"	G 1½"	G 1½"	G 1½"



TECHNICAL DATA I Models with two double coil

TYPE		EV 2x4 2x9 S2 200 60 HP	EV 2x5 2x12 S2 300 65 HP	EV 2x6 2x13 S2 500 65 HP	EV 2x9 2x14 S2 800 95 HP DN18	EV 2x9 2x17 S2 1000 101 HP DN18
Art.number	Nº	305254	305255	305249	305391	305392
Capacity	L	185	269	459	741	921
Net weight	kg	90	122	183	307	324
Insulation (rigid PU)	mm	50	50	50	50	50
Heat exchanger surface S1	m ²	0.65	1	1.55	2.5	2.5
Heat exchanger capacity S1	L	4	6	9.3	14.3	14.4
Heat exchanger surface S2	m ²	1.6	2.45	3.45	3.8	4.6
Heat exchanger capacity S2	L	9.5	14.7	21	14.9	27.5
Heat losses ΔT_{45K}	W	1.4	1.6	2.3	3.1	3.4
Energy efficiency class		B	B	C	C	C
Maximum operational temperature	°C	95	95	95	95	95
Maximum operational temperature of heat exchanger	°C	110	110	110	110	110
Rated pressure	bar	8	8	8	8	8
Rated pressure of the heat exchanger	bar	6	6	6	6	6
Heat exchanger reheat performance P at flow rate of primary side (S1) Coil 80°	kW/(l/min)	14.4[20.8]/ 17.9[41.7]	19.5[25]/ 24.6[50]	28.8[29.2]/ 36.5[58.3]	42.5[50]/ 49.4[100]	51.8[50]/ 63.2[100]
V40 -hot water delivered with a temperature of at least 40 °C (S1) Coil 80°	L	326	459	729.4	1330.7	1354.7
Reheat time 10-60°C rate at primary side (S1)Coil 80°	min/(l/min)	44.41 /20.8 [35.71/41.7]	43/25 [35.2/50]	52.6/29.2, [41.5/58.3]	61.71/50 [51.05/100]	60.38/50, [49.81/100]
Heat exchanger reheat performance P at flow rate of primary side (S2)Coil 80°	kW/(l/min)	28.6[20.8]/ 38.1[41.7]	41.0[25]/ 53.8[50]	54.8[29.2]/ 74.6[58.3]	56.7[50]/ 75.6[100]	81.6[50]/ 104[100]
V40 -hot water delivered with a temperature of at least 40 °C (S2) Coil 80°	L	203	292.1	450.3	703.6	784.6
Reheat time 10-60°C rate at primary side (S2)Coil 80°	min/(l/min)	13.51 /20.8 [10.35/41.7]	13.8/25 [5.7/50]	17.0/29.2, [12.7/58.3]	24.51/50 [17.98/100]	22.31/50, [17.7/100]
Heat exchanger reheat performance P at flow rate of primary side (S1)Coil55° [[kW]/L/min]	kW/(l/min)	6.1[33.3]/ 6.6[50]	7.1[33.3]/ 7.8[50]	10.6[33.3]/ 11.8[50]	14.4[33.3]/ 16.2[50]	51.8[63.2]
V40 -hot water delivered with a temperature of at least 40 °C (S1) Coil55°	L	253	375	601	1043.5	1354.7
Reheat time 10-50°C rate at primary side (S1)Coil55°	min/(l/min)	80.11 /33.3 [73.58/50]	97.93 /33.3 [89.31/50]	109.18 /33.3 [98.56/50]	139.5/33.3 [122.93/50]	60.38/50, [49.81/100]
Heat exchanger reheat performance P at flow rate of primary side (S2)Coil55°	kW/(l/min)	13.4[33.3] /14.6[50]	16.3[33.3]/ 18.9[50]	22.5[33.3]/ 26.1[50]	21.4[33.3]/ 25.1[50]	81.6 [104.0]
V40 -hot water delivered with a temperature of at least 40 °C (S2) Coil55°	L	158	237	395	526.4	784.6
Reheat time 10-50°C rate at primary side (S2)Coil55°	min/(l/min)	22.15 /33.3 [20.18/50]	27.4 /33.3 [24.03/50]	33.35 /33.3 [28.98/50]	49.98/33.3 [43.51/50]	22.31/50, [17.7/100]
Coil Pressure drop at flow rate m3/h (S1)	mBar/(l/min)	4.0[20.8]/ 27.7[41.7]	3.5[25]/ 30.7[50]	17.9[29.2]/ 71.4[58.3]	163[50]/ 638.5[100]	79.7[50]/ 349.4[100]
Coil Pressure drop at flow rate m3/h (S2)	mBar/(l/min)	10.3[20.8]/ 42.1[41.7]	12.0[25]/ 62.8[50]	24.6[29.2]/ 105.2[58.3]	181.5[50]/ 660[100]	104.5[50]/ 440.9[100]
Performance index NL without additional heating S1	-	4.5	8.8	20.8	54	58
Performance index NL without additional heating S2	-	1.6	3.4	8.7	18.5	23.8

DRAWINGS, CONNECTIONS AND DIMENSIONS

Models with two double coils

		EV 2x4 2x9 S2 200 60 HP	EV 2x5 2x12 S2 300 65 HP	EV 2x5 2x9 S2 400 75 HP	EV 2x6 2x13 S2 500 65 HP	EV 2x9 2x14 S2 800 95 HP DN18	EV 2x9 2x17 S2 1000 101 HP DN18
A	mm	996	1184	1135	1447	1591	1625
C	mm	483	533	575	642	810	734
D	mm	996	1184	1225	1447	1779	1846
E	mm	966	1150	1165	1325	1572	1625
F	mm	817	1055	1015	1162	1272	1374
G	mm	519	574	633	706	910	834
H	mm	1197	1420	1477	1677	1974	2012
I	mm	434	485	517	572	710	637
J	mm	202	205	225	225	410	337
K	mm	202	205	225	225	82	81
L	mm	817	1055	1045	1262	1435	1374
M	mm		726	805	864	1005	919
N	mm	360	398	376	467	575	470
R	mm	1345	1560	1345	1823	2014	2100
ØC	mm	600	650	750	750	950	1010
ØD	mm	500	550	650	650	790	850

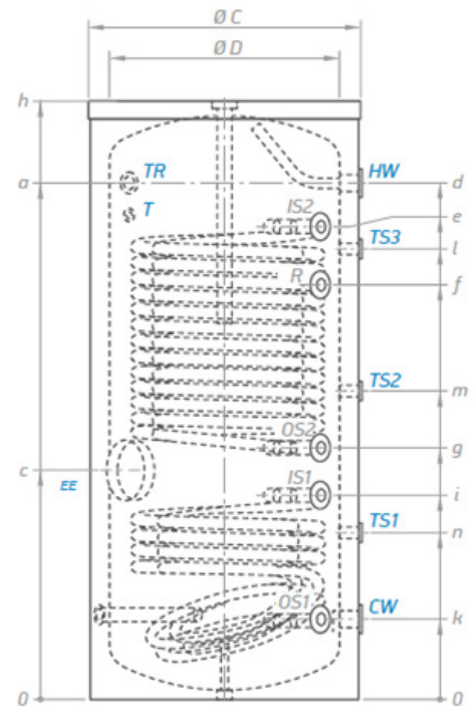

		EV 2x4 2x9 S2 200 60 HP	EV 2x5 2x12 S2 300 65 HP	EV 2x5 2x9 S2 400 75 HP	EV 2x6 2x13 S2 500 65 HP	EV 2x9 2x14 S2 800 95 HP DN18	EV 2x9 2x17 S2 1000 101 HP DN18
CW	cold water inlet	G 1"	G 1"	G 1"	G 1"	G 1½"	G 1½"
HW	hot water outlet	G 1"	G 1"	G 1"	G 1"	G 1½"	G 1½"
IS1	heat exchanger inlet	G 1½"	G 1½"	G 1½"	G 1½"	G 1½"	G 1½"
IS2	heat exchanger inlet	G 1½"	G 1½"	G 1½"	G 1½"	G 1½"	G 1½"
OS1	heat exchanger outlet	G 1½"	G 1½"	G 1½"	G 1½"	G 1½"	G 1½"
OS2	heat exchanger outlet	G 1½"	G 1½"	G 1½"	G 1½"	G 1½"	G 1½"
R	recirculation	G ¾"	G ¾"	G ¾"	G ¾"	G ¾"	G ¾"
T	thermometer	Ø14x1.5	Ø14x1.5	Ø14x1.5	Ø14x1.5	Ø14x1.5	Ø14x1.5
TR	opening for thermoregulator	G ½"	G ½"	G ½"	G ½"	G ½"	G ½"
TS1	thermo pocket level 1	G ½"	G ½"	G ½"	G ½"	G ½"	G ½"
TS2	thermo pocket level 2	G ½"	G ½"	G ½"	G ½"	G ½"	G ½"
EE	opening for electric element	G 1½"	G 1½"	G 1½"	G 1½"	G 1½"	G 1½"

