

EURO-OIL SERIES TYPES G.. G../. OR.. OR../. F.. FR..

AUTOMATIC OIL BURNER CONTROL SYSTEMS

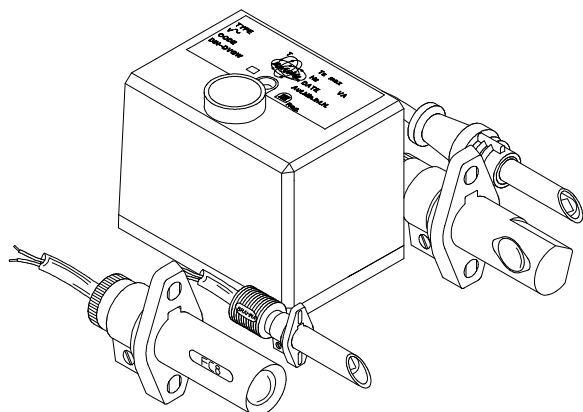

APPLICATION

This range of electronic oil burner controls has been specifically designed for oil burners for non permanent operation.

The automatic burner controls of this series are suitable for:

- monobloc oil burners
- warm air generators
- steam boilers
- power washers
- kilns

Due to the technical and structural characteristics and to the variety of models they can be used for the automation of cookers and oil burner operated appliances for domestic and industrial applications.

FEATURES

Table 1 shows the main features of this series.

Other important features are:

- in accordance with the European standard concerning monobloc oil burners and control systems DIN EN 230: 1991-05;
- types G22, GF3, G33, OR1, OR3, OR1/Z, FR1 and FR2 (only if TV = 20s and TS = 5s) are in compliance also with the standard DIN 4794 part 2, edition December 1980, for warm air generators (WLE);
- two independent safety contacts for oil valve control;
- electrical service life at max load >250.000 operations;
- simple wiring and installation.

	single flame	dual flame	pre-heater (1)	normal operation in case of pre-heating thermostat opening	fuel throughput < 30kg/h	fuel throughput > 30kg/h	pre-ignition	lock-out with extraneous light	external reset	flame detectors FC7/. FC8/.	flame detectors FC11/. FC13/.	remote reset (2)
G22	*		*(1)		*		*	*		*		*
G22/A	*		*(1)		*					*		*
GF2		*			*		*	*		*		*
GF2/A		*			*			*		*		*
GF3		*				*	*	*		*		*
GF3/A		*				*		*		*		*
G33	*		*	*	*		*	*		*		*
OR1	*		*(1)		*		*	*			*	*
OR2		*			*		*	*			*	*
OR3		*				*	*	*			*	*
OR3/B		*	*			*	*	*			*	*
OR1/Z	*		*	*	*		*	*			*	*
F22	*		*(1)		*		*	*	*	*		
FR1	*		*(1)		*		*	*	*		*	
FR2		*			*		*	*	*		*	

(1) Possible application with suitable connection

(2) .../R versions

TECHNICAL DATA

Supply Voltage: 220/240V 50/60Hz
 on request: 110/120V 50/60Hz
Operating temperature range: -20°C +60°C
Ambient humidity: 95% max at 40°C
Protection degree: IP 40
Times
 - Prepurge time (TV) 1,5/10/20/30/40 s
 - Safety time (TS) 5/10 s
 - Dropout time on running flame failure: < 1s
 The times given on the burner control label correspond to the values guaranteed. The actual values slightly differ from the values given, as prepurge time can be longer and safety time shorter than their nominal values.
Power consumption: 18 VA
Contact rating: I max
 - Thermostat: 6,0 A cosφ > 0,4
 - Motor: 2,0 A cosφ > 0,4
 - Ignition transformer: 2,0 A cosφ > 0,4
 - EV1: 0,5 A cosφ > 0,4
 - EV2: 0,5 A cosφ > 0,4
 - Pre-heater: 0,5 A cosφ = 1,0
 - Alarm: 1,0 A cosφ = 1,0
Internal fuse rating: 6,3 A slow blow
External fuse rating: 4,0 A fast
Weight (including socket): 230 g

CONTROLS FOR SPECIAL APPLICATIONS

On request it is possible to meet special requirements concerning times and operating cycles.

CONSTRUCTION

The particular construction and the use of the surface mounted components allow to have reduced overall dimensions.
 The enclosure made of plastic material protects the control from possible damages resulting from crashes, incautious opening, dust and contact with the external environment.
 A varistor protects the control from voltage transients on the electric network.
 An inbuilt fuse protects the internal relays of the control box in case of short circuit on the outputs (valves, ignition transformer, motor and lockout signal).

OVERALL DIMENSIONS

The following figure (Fig.1) shows the overall dimensions of the control.

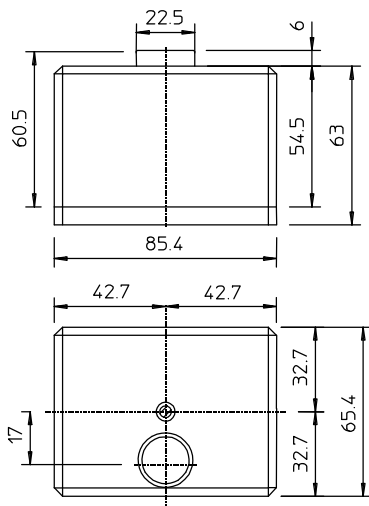
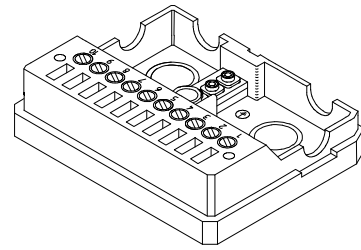

Fig.1

CONNECTION

For the connection of the external components the control can be fitted either with socket type N or type M (see Fig. 2). Socket type M is provided with an auxiliary screw terminal suitable for controls type ../R. Both sockets are provided with a screw terminal board which allows a simple and safety connection. To fix the sockets it is

advisable to use screws type M4. To fix the control to the socket use the pin supplied with the control box.



Socket N

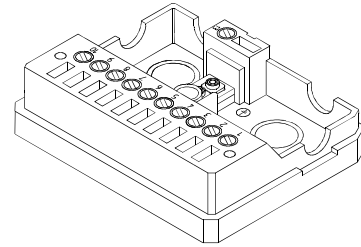

Socket M

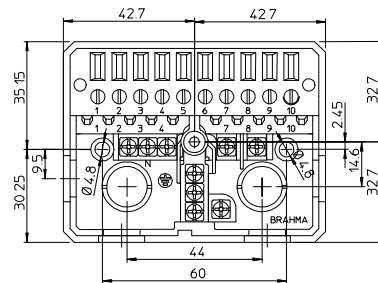
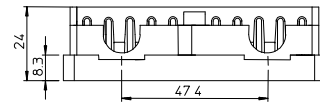

Socket N

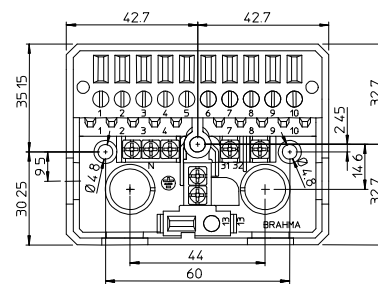
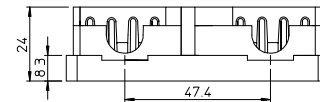

Socket M
Fig.2

ACCESSORIES

The following data are useful to choose the most suitable flame detector for the application and the control box used.

controls

- G22, G22/A, F22, GF2, GF2/A, GF3, GF3/A, G33

flame detectors

	FC8/R	1,5..5,5 lux
frontal side	FC8/A	1,5..3,0 lux
	FC8/V	3,0..5,5 lux
lateral side	FC7/R	1,5..5,5 lux
	FC7/A	1,5..3,0 lux
	FC7/V	3,0..5,5 lux
		4017_r00

- OR1, OR2, OR3, OR3/B,
OR1/Z, FR1, FR2

frontal and lateral side
FC11/R 1,5..6,5 lux
FC11/A 1,5..3,0 lux
FC11/V 3,0..6,5 lux

frontal and lateral side
FC13/R 1,5..6,5 lux
FC13/A 1,5..3,0 lux
FC13/V 3,0..6,5 lux

The suffix indicates the colour of the photocell enclosure:

/R	red
/A	blue
/V	green

The following figures (Fig.3 and Fig.4) show the types and fixing systems of the available flame detectors.

To fix the flame detector screws diameter 4 are suggested.

Drilling plane FC7 FC8

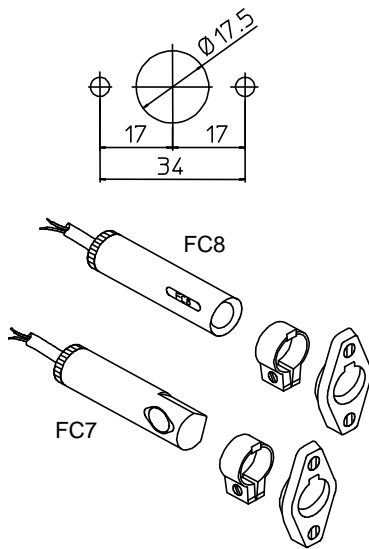

Fig.3

Drilling plane FC13 Drilling plane FC11

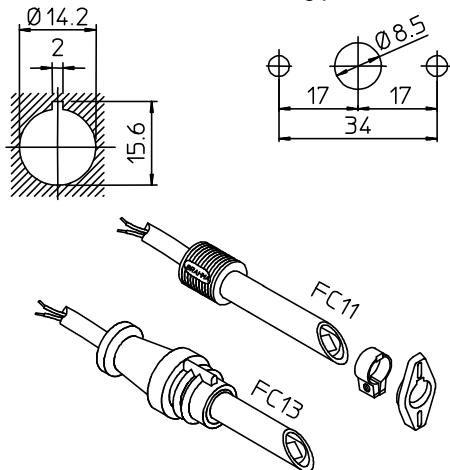

Fig.4

Cable holders and core hitches can be fitted on the sides of the enclosure and the connecting sockets. These accessories can be supplied upon request (see Fig.5).

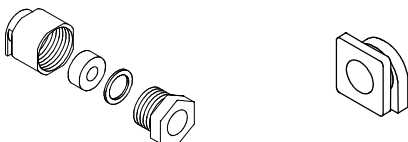

Fig.5

DIRECTIONS FOR USE

- Automatic controls are safety devices and must not be opened. The manufacturer's responsibility and guarantee are invalidated if the control is incautiously opened.
- For safety reasons a regulation shutdown must occur every 24 hours (systems for non permanent operation).
- The control can be connected and disconnected only without the main power.
- The control can be mounted in any position.
- Avoid exposing the control unit to dripping water.
- Ventilation and the lowest temperature ensure the longest life of the control.
- Make sure that the type (code and times) you are using is correct before installing or replacing the control.

ELECTRICAL INSTALLATION

- The applicable national and European standards (e.g. EN 60335-1 / prEN 50165) regarding electrical safety must be respected.
- **Live** and **neutral** should be connected correctly; a mistake could cause a dangerous situation, as the internal safety devices can be ineffective in case the connecting wires of thermostats and valves are not isolated.
- Before starting the control unit check the cables carefully. Wrong connections can damage the control and compromise the safety of the application.
- The earth terminal of the control, the metal frame of the burner and the earth of the electric system must be well connected.
- Avoid putting detection cables close to power or ignition cables.
- Protect the control with a fast fuse suitable to the load connected and never exceeding 4A.
- The appliance in which the control is installed must provide adequate protection against the risk of electrical shock.

CHECKING AT START

Always check the control before the first start and also after any replacement or a long period of non operation of the system.

Before any ignition attempt make sure that the combustion chamber is free from oil.

Then make sure that:

- if the starting attempt occurs with the flame detector obscured the control performs a lockout after safety time;
- if start up takes place with extraneous light the control performs a lockout within 10 seconds;
- when the flame detector is obscured in running position, supply to the oil valves is interrupted within 1 second and after a recycling the control proceeds to lockout;
- the intervention of limiters or safety devices cause a safety shutdown according to the application;
- operating times and sequence are suitable to the control box used.

OPERATION

At every start the control unit supplies the burner motor and the ignition transformer and proceeds to a self-checking of its own components. During the prepurge time TV the internal circuit makes a test of the flame signal amplifier circuit. Extraneous light or a fault in the amplifier cause the lockout of the control within 10 seconds.

At the end of prepurge time the control output of the first oil valve is energized; if a flame signal is detected at the end of safety time, the control unit deenergizes the ignition transformer and goes to running position.

At the end of safety time in the controls with two flame levels the ignition transformer is deenergized and the second oil valve is supplied. If no flame signal is detected during safety time, the control goes to lockout, the control outputs of the valve, the ignition transformer and the burner motor are switched off while the lockout signal is supplied. The controls prearranged for the use of an oil pre-heater supply the pre-heater when the ambient thermostat and/or the boiler switch off. In this way the starting sequence begins.

In types G33 and OR1/Z the thermostat opening does not cause the burner shutdown; if the pre-heater is used with types G22-G22/A-F22-FR1-OR1, the thermostat opening causes the repetition of the starting sequence after the heating stage (RISC) of the pre-heater.

Although the OR3/B control is prearranged for the use of an oil pre-heater, when the thermostat switches on the control performs a new starting sequence after the heating stage (RISC) of the pre-heater. All control units marked with the /A suffix do not perform the pre-ignition stage.

The attached diagrams are useful to understand how each control operates.

Abnormal operation - Extraneous light

All control boxes of this series perform a lockout within 10 seconds, except for type G22/A, which causes the burner to continue the prepurge stage.

RESET OF THE CONTROL

When a control has gone to lockout, a delay of 10 seconds should be considered before attempting to reset the control unit; if this time is not observed the control may not reset.

TESTING THE FLAME SIGNAL

It is extremely important to test the flame signal level before having the burner operate.

Arrange one cable connected to terminal no. 9 and one cable connected to the neutral terminal. These cables should be accessible when the control is mounted on the socket; then, with the burner in running position, the voltage between terminals must be $< 0,5V$.

This value guarantees a safe operation; it corresponds to a light intensity 50% beyond the limit value (about 0,8V). In case the tested voltage is higher, try to better orientate the photocell or to clean it (see Fig.6).

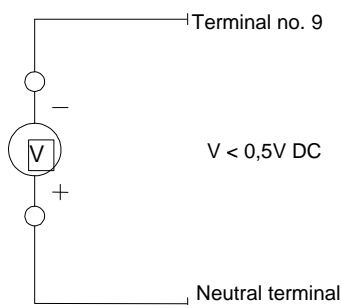

CONNECTION DIAGRAMS

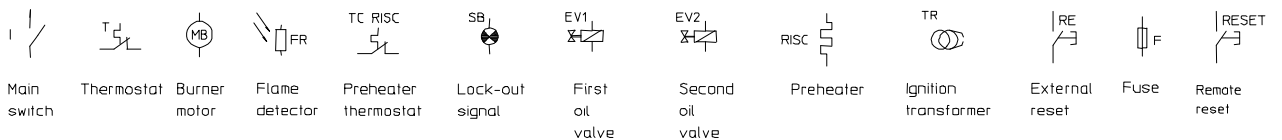
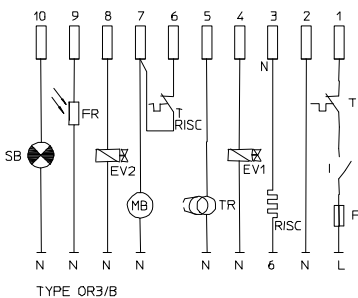
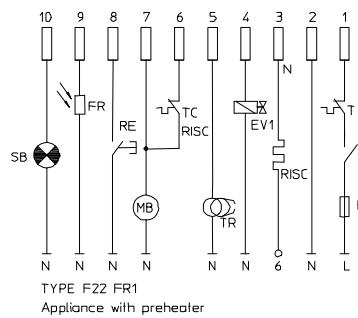
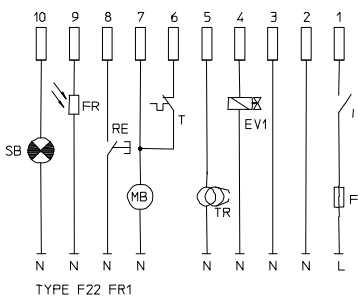
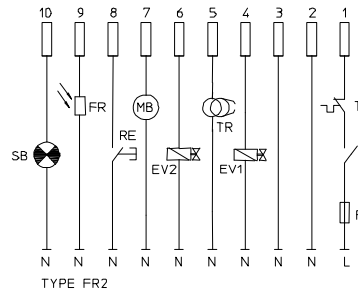
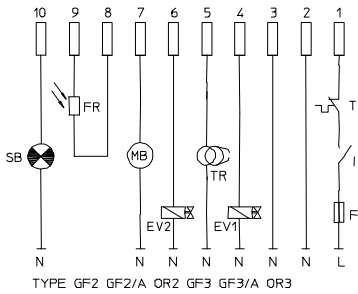
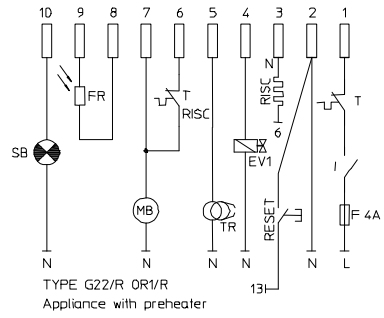
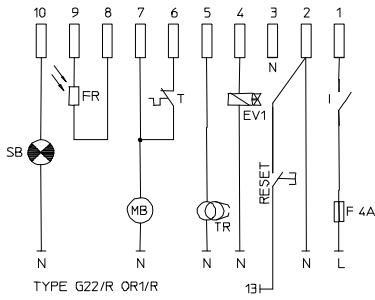
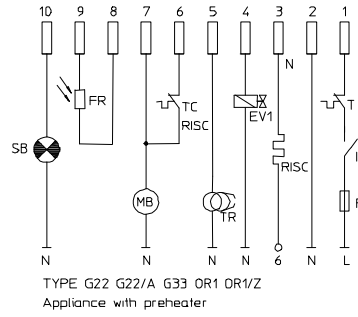
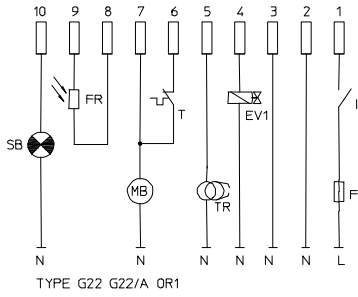

OPERATING CYCLES

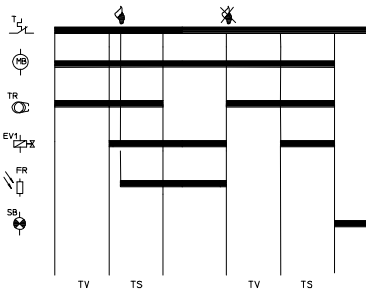

TYPE G22 G22/R OR1 OR1/R F22 FR1

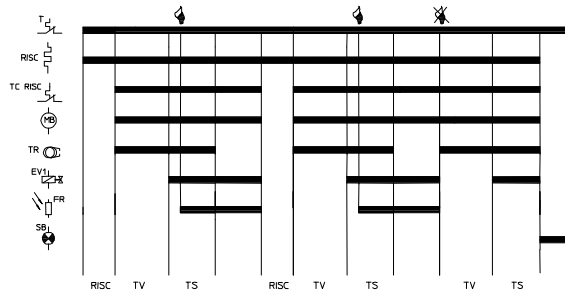

TYPE G22 OR1 F22 FR1 G22/R OR1/R Appliance with preheater

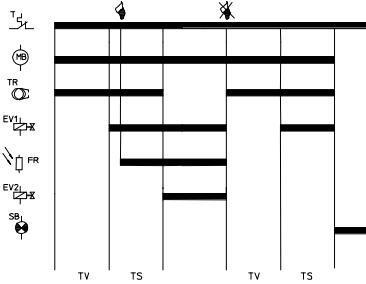

TYPE GF2 OR2 GF3 OR3 FR2

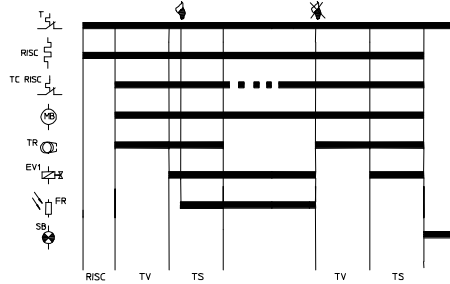

TYPE G33 OR1/Z

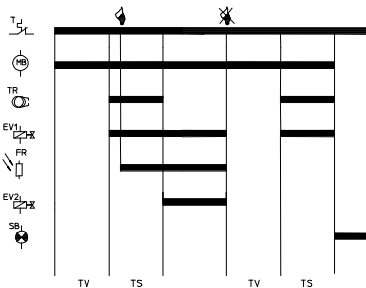

TYPE GF2/A GF3/A

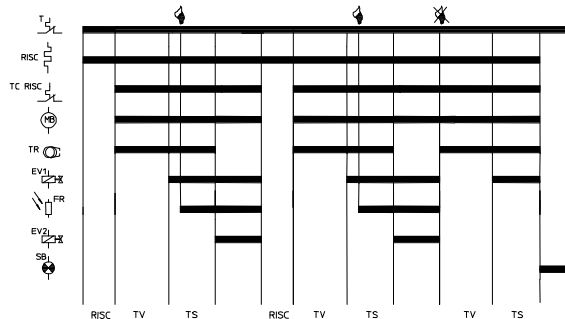

TYPE OR3/B

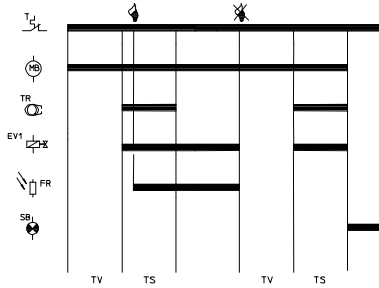

TYPE G22/A

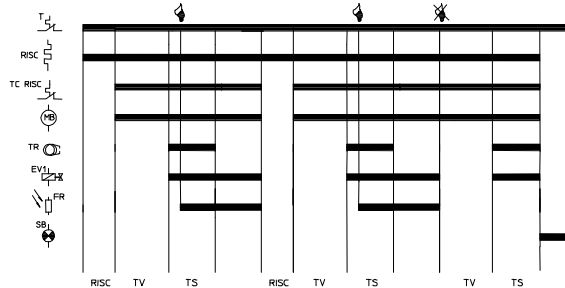

TIPO G22/A Appliance with preheater

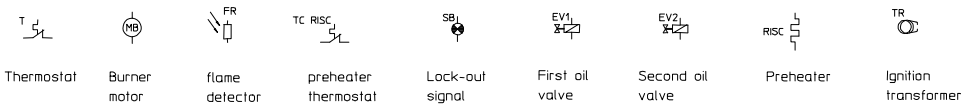

Euro-oil Series Types G.. G../. OR.. OR../. F.. FR..

BRAHMA S.p.A.
Via del Pontiere, 31
37045 Legnago (VR)
Tel. +39 0442 635211 - Telefax +39 0442 25683
<http://www.brahma.it>
E-mail : brahma@brahma.it

03/03/27 Subject to amendments without notice