

Wall-Mounted Indoor Unit

Installation & Owner's Manual

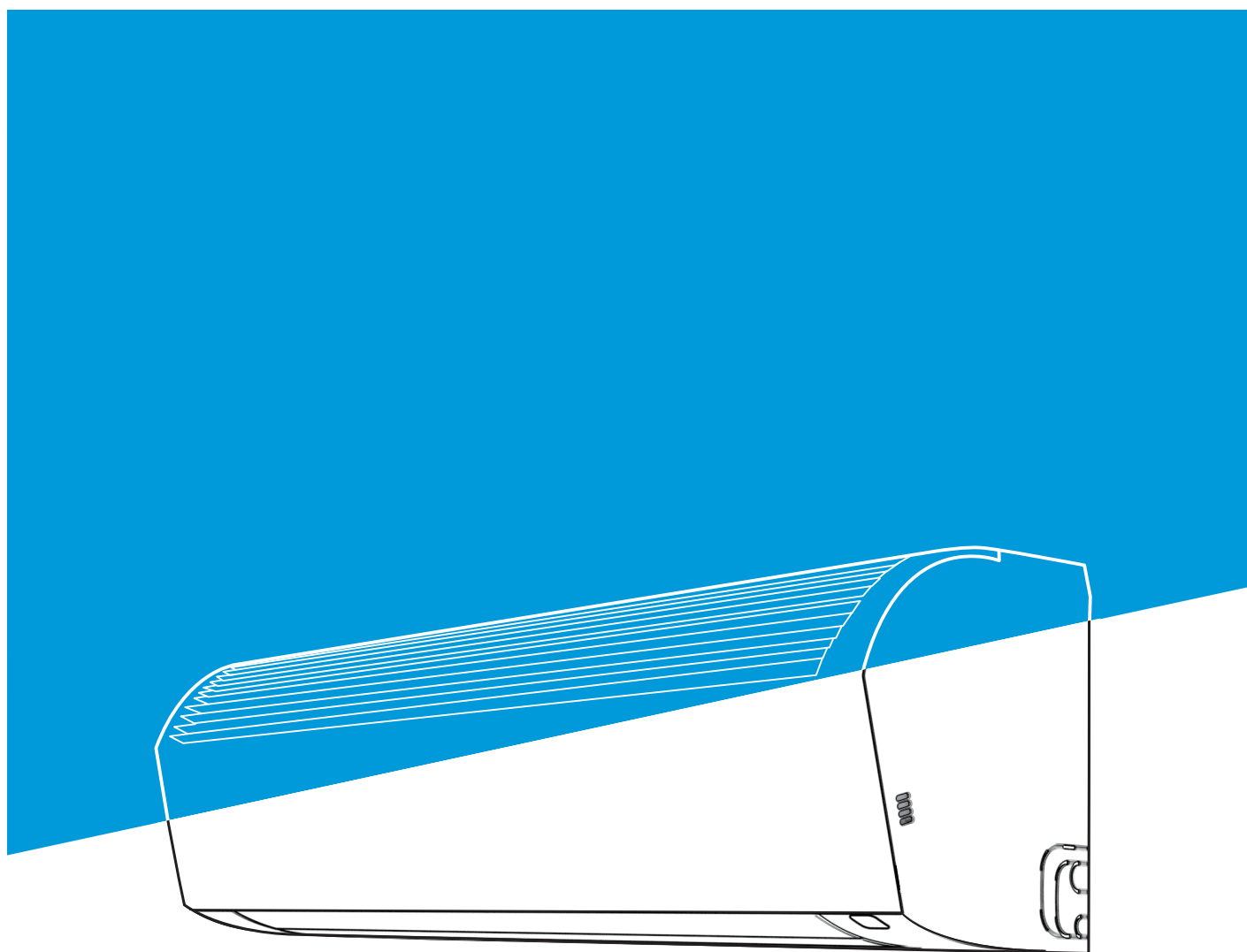

Read this manual carefully before using the product, and keep it handy for future reference.

The product picture on the cover page is for reference only.

Preface

Dear users,

Thank you for purchasing and using our product. Please read this manual carefully before you install, use, maintain or troubleshoot this product so that you can familiarize yourself with the product and use it correctly.

For ODUs or other IDUs, please refer to the applicable installation & owner's manuals provided with them.

For detailed operation of auxiliary control devices, such as wired, remote and centralized controllers, please refer to their instructions.

To ensure the correct installation and operation of the product, the following instructions are provided:

- ④ To ensure the correct and safe operation of the product, please strictly follow the requirements listed in this manual.
- ④ All figures and contents in this manual are for reference only. Due to continuing product improvement, the specifications are subject to change without notice.
- ④ Regular cleaning and maintenance of the product are required for intended performance and long service life. Each year before using the air conditioner, please contact your local dealer, and we will assign professionals to provide paid services of cleaning, maintenance, and inspection.
- ④ Please retain this manual for future reference.

Contents

Safety Warning 1

Warning Signs / 1

Electric Safety Requirements / 3

Safety Precautions / 2

Appendix / 3

Operation 7

Operating Precautions / 7

Symptoms That Are Not Faults / 10

Optimum Operation / 8

Display Panel / 12

Installation 13

Installation Precautions / 13

Electrical Connection / 38

Test Run / 59

Product Installation / 19

Application Control / 54

Cleaning, Maintenance and After-Sales Service 61

Safety Warning / 61





Maintenance of Conventional Parts / 64

Cleaning and Maintenance / 61

Please thoroughly read and ensure that you fully understand the safety precautions (including the signs and symbols) in this manual, and follow relevant instructions during use to prevent damage to health or property.

Safety Warning

Explanation of symbols displayed on the unit

	WARNING	This symbol shows that this appliance used a flammable refrigerant. If the refrigerant is leaked and exposed to an external ignition source, there is a risk of fire.
	CAUTION	This symbol shows that the operation manual should be read carefully.
	CAUTION	This symbol shows that a service personnel should be handling this equipment with reference to the installation manual.
	CAUTION	This symbol shows that information is available such as the operating manual or installation manual.



Caution: Risk of fire

(for IEC 60335-2-40: 2018 only)



Caution: Risk of fire

(for IEC/EN 60335-2-40 except IEC 60335-2-40: 2018)

Note

The symbols above is for R32 refrigerant system.

1 Warning Signs

Different marks are used to indicate the levels of hazard severity. Please follow the instructions and ensure safe operation.



Danger

Indicates a hazard with a high level of risk which, if not avoided, will result in death or serious injury.



Warning

Indicates a hazard with a medium level of risk which, if not avoided, could result in death or serious injury.



Caution

Indicates a hazard with a low level of risk which, if not avoided, could result in minor or moderate injury.



Note

Useful operation and maintenance information.

Warning contents



Ensure Proper Grounding



Professional Only

Prohibition signs



No Flammable Materials



No Strong Current



No Open Fire



No Acid or Alkali Materials

2 Safety Precautions

Danger

During thunderstorms, disconnect the main power switch. Otherwise, lightning may damage the unit.

In the event of refrigerant leakage, smoking and open flames are prohibited. Disconnect the main power switch immediately, open windows to allow ventilation, keep away from the leakage point, and contact your local dealer or technical support to request a professional repair.

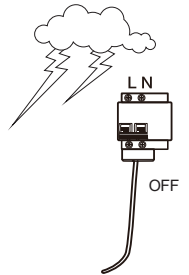

Warning

Air conditioner installation must comply with local standards and electrical codes, and relevant instructions in this manual.

Do not use any liquid cleanser, liquefied cleanser, or corrosive cleanser to wipe this unit or spray water or other liquids on the unit. Otherwise, the plastic parts of the unit will become damaged and an electrical shock may occur. Disconnect the main power switch before cleaning and maintenance to avoid accidents.

Ask a professional to remove and reinstall the air conditioner.

Ask a professional for maintenance and repair assistance.

The IDU shall be placed at a height not accessible to children, at least 2.5m above the ground.

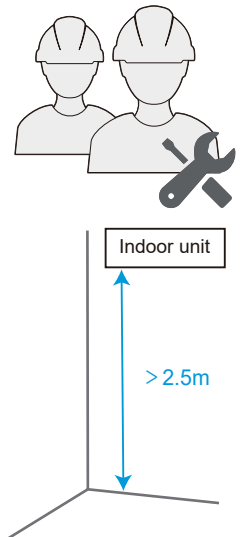

Caution

This appliance can be used by children aged from 8 years and above and persons with reduced physical, sensory or mental capabilities or lack of experience and knowledge if they have been given supervision or instruction concerning use of the appliance in a safe way and understand the hazards involved.

Children shall not play with the appliance.

Cleaning and user maintenance shall not be made by children without supervision.

This appliance is intended to be used by expert or trained users in shops, in light industry and on farms, or for commercial use by lay persons.

When the product is used for commercial application. This appliance is intended to be used by expert or trained users in shops, in light industry and on farms, or for commercial use by lay persons, the sound pressure level is below 70 dB(A).

3 Electric Safety Requirements

Warning

The air conditioner shall be installed according to the local wiring specifications.

Wiring work must be completed by qualified electricians.

All wiring work must comply with electrical safety specifications.

The air conditioner must be well grounded. Specifically, the main switch of the air conditioner must have a reliable grounding cable.

Before contacting wiring devices, cut off all the power supplies.

The user **MAY NOT** disassemble or repair the air conditioner. Doing so can be dangerous. In the event of a fault, immediately cut off the power and contact your local dealer or technical support.

A separate power supply that meets the rated parameter values must be provided for the air conditioner.

The fixed wiring to which the air conditioner is connected must be equipped with a power cut-off device that meets the wiring requirements.

To avoid danger, a damaged power cable must be replaced by professionals from the maintenance department or a similar department of the manufacturer.

The air conditioner's circuit board (PCB) is designed with a fuse to provide overcurrent protection.

The specifications of the fuse are printed on the circuit board.

NOTE: For the units with R32 refrigerant, only the blast-proof ceramic fuse can be used.

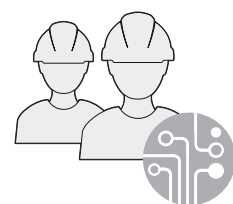
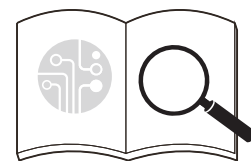

Caution

Always ground the main power switch.

Do not use a damaged power cable and replace it if it is damaged.

When the air conditioner is used for the first time or is in a power-off state for a long time, it needs to be connected to the power supply and warmed up for at least 12 hours before use.



4 Appendix

Warning

The following applies to R32 refrigerant systems.

Prior to beginning work on systems containing flammable refrigerants, safety checks are necessary to ensure that the risk of ignition is minimized.

For repair to the refrigerating system, the following precautions shall be complied with prior to conducting work on the system.

Work shall be undertaken under a controlled procedure so as to minimise the risk of a flammable gas or vapour being present while the work is being performed.

All maintenance staff and others working in the local area shall be instructed on the nature of work being carried out. Work in confined spaces shall be avoided. The area around the workspace shall be sectioned off. Ensure that the conditions within the area have been made safe by control of flammable material.

The area shall be checked with an appropriate refrigerant detector prior to and during work, to ensure the technician is aware of potentially flammable atmospheres.

Ensure that the leak detection equipment being used is suitable for use with flammable refrigerants, i.e. non-sparking, adequately sealed or intrinsically safe.

If any hot work is to be conducted on the refrigeration equipment or any associated parts, appropriate fire extinguishing equipment shall be available to hand. Have a dry powder or CO2 fire extinguisher adjacent to the charging area.

No person carrying out work in relation to a refrigeration system which involves exposing any pipe work that contains or has contained flammable refrigerant shall use any sources of ignition in such a manner that it may lead to the risk of fire or explosion.

All possible ignition sources, including cigarette smoking, should be kept sufficiently far away from the site of installation, repairing, removing and disposal, during which flammable refrigerant can possibly be released to the surrounding space.

Prior to work taking place, the area around the equipment is to be surveyed to make sure that there are no flammable hazards or ignition risks. "No Smoking" signs shall be displayed.

Ensure that the area is in the open or that it is adequately ventilated before breaking into the system or conducting any hot work. A degree of ventilation shall continue during the period

that the work is carried out. The ventilation should safely disperse any released refrigerant and preferably expel it externally into the atmosphere.

Where electrical components are being changed, they shall be fit for the purpose and to the correct specification. At all times the manufacturer's maintenance and service guidelines shall be followed. If in doubt consult the manufacturer's technical department for assistance.

The following checks shall be applied to installations using flammable refrigerants:

- the charge size is in accordance with the room size within which the refrigerant containing parts are installed;
- the ventilation machinery and outlets are operating adequately and are not obstructed;
- if an indirect refrigerating circuit is being used, the secondary circuit shall be checked for the presence of refrigerant;
- marking to the equipment continues to be visible and legible. Markings and signs that are illegible shall be corrected;
- refrigeration pipe or components are installed in a position where they are unlikely to be exposed to any substance which may corrode refrigerant containing components, unless the components are constructed of materials which are inherently resistant to being corroded or are suitably protected against being so corroded.

Repair and maintenance to electrical components shall include initial safety checks and component inspection procedures.

If a fault exists that could compromise safety, then no electrical supply shall be connected to the circuit until it is satisfactorily dealt with. If the fault cannot be corrected immediately but it is necessary to continue operation, an adequate temporary solution shall be used. This shall be reported to the owner of the equipment so all parties are advised.

Initial safety checks shall include:

- that capacitors are discharged: this shall be done in a safe manner to avoid possibility of sparking;
- that no live electrical components and wiring are exposed while charging, recovering or purging the system;
- that there is continuity of earth bonding.

During repairs to sealed components, all electrical supplies shall be disconnected from the equipment being worked upon prior to any removal of sealed covers, etc. If it is absolutely necessary to have an electrical supply to equipment during servicing, then a permanently operating form of leak detection shall be located at the most critical point to warn of a potentially hazardous situation.

Particular attention shall be paid to the following to ensure that by working on electrical components, the casing is not altered in such a way that the level of protection is affected. This shall include damage to cables, excessive number of connections, terminals not made to original specification, damage to seals, incorrect fitting of glands, etc.

Ensure that seals or sealing materials have not degraded such that they no longer serve the purpose of preventing the ingress of flammable atmospheres.

Replacement parts shall be in accordance with the manufacturer's specifications.

Do not apply any permanent inductive or capacitance loads to the circuit without ensuring that this will not exceed the permissible voltage and current permitted for the equipment in use.

Intrinsically safe components are the only types that can be worked on while live in the presence of a flammable atmosphere. The test apparatus shall be at the correct rating.

Replace components only with parts specified by the manufacturer. Other parts may result in the ignition of refrigerant in the atmosphere from a leak.

Check that cabling will not be subject to wear, corrosion, excessive pressure, vibration, sharp edges or any other adverse environmental effects. The check shall also take into account the effects of ageing or continual vibration from sources such as compressors or fans.

When breaking into the refrigerant circuit to make repairs – or for any other purpose – conventional procedures shall be used. However, it is important that best practice is followed.

Since flammability is a consideration. The following procedure shall be adhered to:

- remove refrigerant;
- purge the circuit with inert gas;
- evacuate;
- purge again with inert gas;
- open the circuit by cutting or brazing.

The refrigerant charge shall be recovered into the correct recovery cylinders. The system shall be “flushed” with OFN to render the unit safe. This process may need to be repeated several times. Compressed air or oxygen shall not be used for this task.

Flushing shall be achieved by breaking the vacuum in the system with OFN and continuing to fill until the working pressure is achieved, then venting to atmosphere, and finally pulling down to a vacuum.

This process shall be repeated until no refrigerant is within the system. When the final OFN charge is used, the system shall be vented down to atmospheric pressure to enable work to take place.

This operation is absolutely vital if brazing operations on the pipe-work are to take place.

Ensure that the outlet for the vacuum pump is not close to any ignition sources and there is ventilation available.

Ensure that contamination of different refrigerants does not occur when using charging equipment. Hoses or lines shall be as short as possible to minimise the amount of refrigerant contained in them.

Prior to recharging the system it shall be pressure tested with OFN.

DD.12 Decommissioning:

Before carrying out this procedure, it is essential that the technician is completely familiar with the equipment and all its detail. It is recommended good practice that all refrigerants are recovered safely. Prior to the task being carried out, an oil and refrigerant sample shall be taken in case analysis is required prior to re-use of reclaimed refrigerant. It is essential that electrical power is available before the task is commenced.

- a) Become familiar with the equipment and its operation.
- b) Isolate system electrically.
- c) Before attempting the procedure ensure that:
 - *mechanical handling equipment is available, if required, for handling refrigerant cylinders;*
 - *all personal protective equipment is available and being used correctly;*
 - *the recovery process is supervised at all times by a competent person;*
 - *recovery equipment and cylinders conform to the appropriate standards.*
- d) Pump down refrigerant system, if possible.
- e) If a vacuum is not possible, make a manifold so that refrigerant can be removed from various parts of the system.
- f) Make sure that cylinder is situated on the scales before recovery takes place.
- g) Start the recovery machine and operate in accordance with manufacturer's instructions.
- h) Do not overfill cylinders. (No more than 80 % volume liquid charge).
- i) Do not exceed the maximum working pressure of the cylinder, even temporarily.
- j) When the cylinders have been filled correctly and the process completed, make sure that the cylinders and the equipment are removed from site promptly and all isolation valves on the equipment are closed off.
- k) Recovered refrigerant shall not be charged into another refrigeration system unless it has been cleaned and checked.

Equipment shall be labelled stating that it has been de-commissioned and emptied of refrigerant. The label shall be dated and signed. Ensure that there are labels on the equipment stating the equipment contains flammable refrigerant.

When removing refrigerant from a system, either for servicing or decommissioning, it is recommended good practice that all refrigerants are removed safely.

When transferring refrigerant into cylinders, ensure that only appropriate refrigerant recovery cylinders are employed. Ensure that the correct number of cylinders for holding the total system charge are available. All cylinders to be used are designated for the recovered refrigerant and labelled for that refrigerant (i.e. special cylinders for the recovery of refrigerant). Cylinders shall be complete with pressure relief valve and associated shut-off valves in good working order. Empty recovery cylinders are evacuated and, if possible, cooled before recovery occurs.

The recovery equipment shall be in good working order with a set of instructions concerning the equipment that is at hand and shall be suitable for the recovery of flammable refrigerants. In addition, a set of calibrated weighing scales shall be available and in good working order. Hoses shall be complete with leak-free disconnect

couplings and in good condition. Before using the recovery machine, check that it is in satisfactory working order, has been properly maintained and that any associated electrical components are sealed to prevent ignition in the event of a refrigerant release. Consult manufacturer if in doubt.

The recovered refrigerant shall be returned to the refrigerant supplier in the correct recovery cylinder, and the relevant Waste Transfer Note arranged. Do not mix refrigerants in recovery units and especially not in cylinders.

If compressors or compressor oils are to be removed, ensure that they have been evacuated to an acceptable level to make certain that flammable refrigerant does not remain within the lubricant. The evacuation process shall be carried out prior to returning the compressor to the suppliers. Only electric heating to the compressor body shall be employed to accelerate this process. When oil is drained from a system, it shall be carried out safely.

Warning: disconnect the appliance from its power source during service and when replacing parts.

These units are partial unit air conditioners, complying with partial unit requirements of this International Standard, and must only be connected to other units that have been confirmed as complying to corresponding partial unit requirements of this International Standard.

Operation

1 Operation Precautions

Warning

If the unit will be not used for a long time, disconnect the main power switch. Otherwise, an accident may occur.

The installation height of the air conditioner shall be at least 2.5m above the ground to avoid the following risks:

1. *Touching of moving or live parts, such as fans, motors, or louvers, by a non professional. Running parts may cause harm to you or transmission assemblies may become damaged.*
2. *Getting too close to the air conditioner may reduce the level of comfort.*

When the product is used with a burning appliance, the room must be ventilated regularly. Otherwise, it may cause an insufficient oxygen supply.

Do not let children play with the air conditioner. Otherwise, an accident may occur.

Do not expose the IDUs or controller to moisture or water as this may cause short circuiting or fire.

Do not place any appliance that uses an open flame in the direct air supply of the air conditioner as it could interfere with the combustion of the appliance.

Do not use or store flammable gases or liquids such as natural gas, hair spray, paint or gasoline near the air conditioner. Otherwise, a fire may occur.

To avoid causing harm, do not place animals or plants directly in front of the air conditioner's air supply.

In the event of abnormal conditions such as abnormal noise, smell, smoke, temperature rise, and electric leakage, please cut off the power immediately, and then contact your local dealer or air conditioner customer service center. Do not repair the air conditioner by yourself.

Do not place flammable sprayers near the air conditioner or spray it directly at the air conditioner. Otherwise, a fire may occur.

Do not place a container of water on the air conditioner. If immersed in water, the air conditioner's electrical insulation will weaken, resulting in electrical shock.

After long-term use, confirm whether the installation platform has become worn. If it is worn, the unit could fall, causing injury.

Do not operate the switch with wet hands, as this may result in electric shock.

When servicing the air conditioner, be sure to turn off the air conditioner and cut off the power supply. Otherwise, the high-speed operation of the internal fan will cause injury.

The air conditioner cannot be used to preserve food, animals and plants, precision instruments and works of art, etc.; otherwise, quality degradation could occur.

Do not use fuses like iron or copper wire other than those with the specified capacity. Otherwise, a malfunction or fire may occur. The power supply must use the special circuit of the air conditioner at the rated voltage.

Do not place valuables under the air conditioner. Air conditioner condensation problems may damage the valuables.

When the air conditioner needs to be moved and re-installed, please entrust the local dealer or a professional technician to operate it.

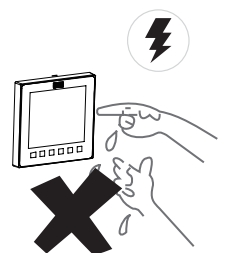
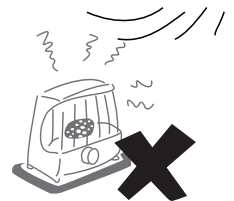

Disposal: Do not dispose of this product as unsorted municipal waste. Collection of such waste separately for special treatment is necessary.

Do not dispose of electrical appliances as unsorted municipal waste, use separate collection facilities. Contact your local government for information regarding the collection systems available.

If electrical appliances are disposed of in landfills or dumps, hazardous substances can leak into the groundwater and get into the food chain, damaging your health and well-being.



Caution

To use the unit normally, please follow the "Operation" section in this manual. Otherwise, the internal protection may be triggered, the unit may begin to drip, or the unit's cooling and heating effects may be impacted.

The room temperature should be set properly, especially when there are elderly, children, or patients in the room.

Lightning or the starting and stopping of large electrical equipment in nearby factories may cause misoperation of the air conditioner. Please turn off the main power switch for a few seconds, and then restart the air conditioner.

To avoid accidental resetting of the thermal circuit breaker, the air conditioner cannot be powered by an external switching device such as a timer or connected to a circuit that is turned on and off by a common component timer.

Check whether the air filter is installed properly. Confirm that the inlet and outlet ports of the IDU/ODU are not blocked.

If the air conditioner will not be used for a long time, please clean the air filter before starting the air conditioner. Otherwise, dust and mold on the filter could contaminate the air or produce an unpleasant smell. For more details, please refer to the section "Cleaning and Maintenance".

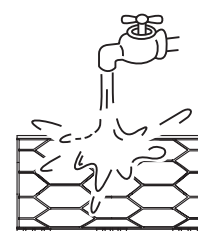
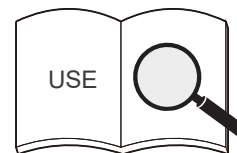

2 Optimum Operation

As cold air sinks and hot air rises, adjust the direction of louvers respectively in cooling and heating modes to ensure good cooling and heating effects.

In Cooling Mode

To improve the cooling effect in the entire room, adjust the louvers of the air outlet grille horizontally.

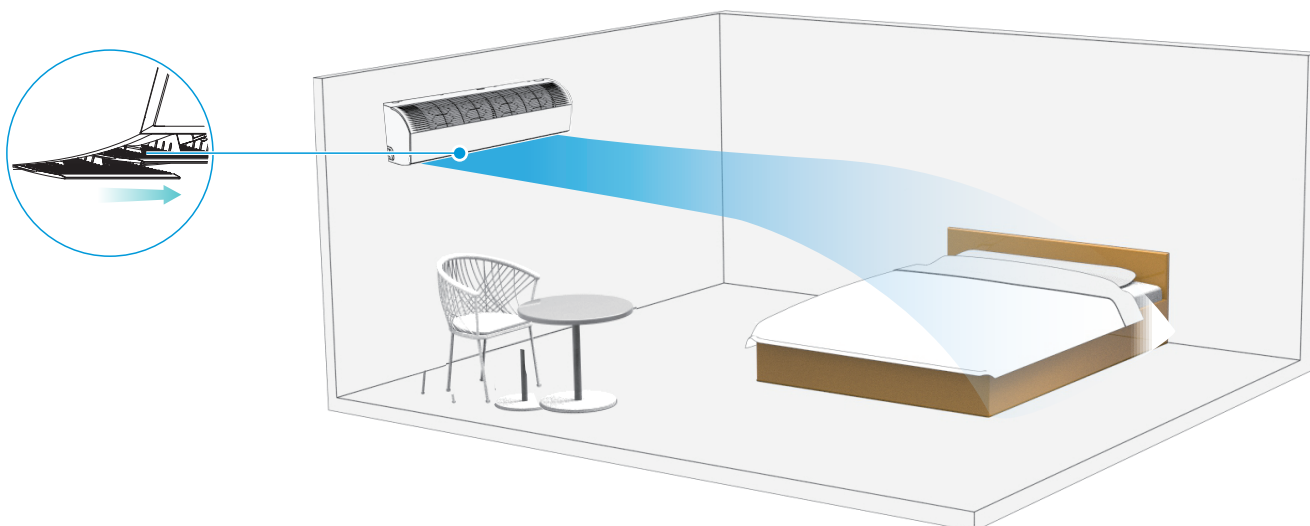

In Heating Mode

To improve the heating effect in the lower parts of a room, adjust the louvers of air outlet grille downwards.

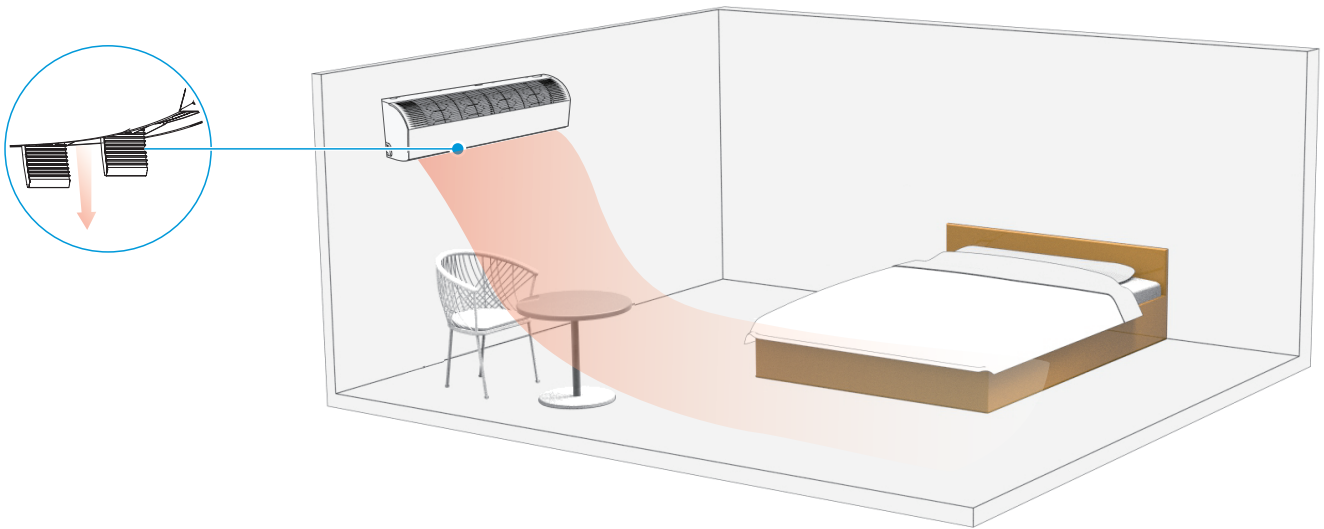

Operating Range

To maintain good performance, operate the air conditioner under the following temperature conditions:

Cooling	Indoor temperature	16~32°C
	Indoor humidity	≤80% (When the humidity exceeds 80%, long-time operation of the IDU may cause dew condensation on the surface of the IDU or generate mist-like cold air from the air outlet.)
Heating	Indoor temperature	15~30°C

Caution

The IDU operates stably within the temperature range given in the table above. If it exceeds this normal operating range, the IDU may stop running.

3 Symptoms That Are Not Faults

Normal Protection of the Air Conditioner

During operation, the following phenomena are normal and do not require maintenance.



When the power switch is on, if you start the system right after it is stopped, it is normal that the ODU does not operate for about four minutes as frequent compressor start/stop is not supported.



In heating mode (including heating in automatic mode), when the indoor heat exchanger does not reach a certain temperature, the indoor fan temporarily shuts off, or runs in Low mode until the heat exchanger heats up to prevent the blowing of cold air.



When the outdoor temperature is low and the humidity is high, frost may build up on the ODU's heat exchanger, which may reduce the heating capacity of the air conditioner. In this case, the air conditioner will stop heating, enter automatic defrosting mode, and return to heating mode after defrosting has been completed.

During the defrosting, the outdoor fan stops running and the indoor fan runs using the anti-cold air protection function.

The defrosting operation time varies depending on the outdoor temperature and the degree of frosting. It generally takes 2 to 10 minutes.

During the defrosting process, the ODU may emit steam due to the rapid defrosting, which is normal.



When the IDU detects high humidity, the air conditioner will adjust the louver angle and the fan speed to prevent condensation and avoid dripping.

Normal Phenomena that Are Not Air Conditioner Faults

The following phenomena are normal during operation of the air conditioner. They can be solved according to the instructions below or do not need to be solved.

■ The IDU emits white mist

1. In an environment where the indoor relative humidity is too high, when the IDU runs in cooling mode, white mist may appear due to the humidity and the temperature difference between the air inlet and outlet.
2. When the air conditioner is switched to heating mode after defrosting, the IDU discharges the moisture generated from defrosting as steam.

■ The IDU blows dust

When the air conditioner has not been used for a long time or is used for the first time, the air filter should be cleaned. Otherwise, dust that has entered the IDU will be blown out.

■ The IDU emits odor

The IDU absorbs the odors of rooms, furniture or cigarettes, etc., and disperses the odors during operation. It is advised to have the air conditioner cleaned and maintained regularly by professional technicians.

■ Water drips on the air conditioner surface

When the indoor relative humidity is high, it is normal for condensation or slight water blowing to occur on the surface of the air conditioner.

■ "Self-cleaning" sound of icing

During self-cleaning, there may be a slight clicking sound for about 10 minutes, indicating that the IDU is freezing, which is normal.

■ The air conditioner makes low noise

1. When the air conditioner is in "Auto", "Cool", "Dry", and "Heat" modes, it may emit a low continuous "hissing" sound, which is caused by the refrigerant flowing between the IDU and the ODU.
2. A "hissing" sound may be heard for a short time after the air conditioner stops operation or during "defrosting", which is caused when the refrigerant stops flowing or changes its flow.
3. When the air conditioner is in Cool mode or Dry mode, a small and continuous rustling sound can be heard, which is caused by the drain pump.
4. When the air conditioner starts or stops running, you may hear a squeaking sound which is produced by the expansion or shrinkage of parts or surrounding aesthetic materials due to temperature change. The sound will disappear when the air conditioner is running normally.

■ Switching from cooling/heating (not available for cooling only units) mode to fan only mode

When the IDU reaches the set temperature, the air conditioner compressor automatically stops operation and switches to the fan only mode. When the room temperature rises (in cooling mode) or falls (in heating mode) to a certain level, the compressor is restarted and cooling or heating operation is resumed.

■ In winter, the outdoor temperature is low, and heating effects may be decreased

1. During the heating operation of the heat pump type air conditioner, the air conditioner absorbs heat from the outdoor air and releases it to heat the indoor air. This is the heat pump heating principle of the air conditioner.
2. When the heat pump runs in heating mode, the ODU blows out cold air, causing the outdoor temperature to drop. When the outdoor temperature is extremely low, the heating capability of the air conditioner drops gradually. You are advised to use other heating devices for heating.

■ No heating or cooling options

All IDUs in the same air conditioning system can only operate in the same mode, for example, cooling, heating, or others. Conflict may occur if IDUs are set to different modes. Only the IDU that is first started up can determine the operating mode, and those started after it can only follow the operating mode of the first IDU. To change the operating mode, you need to turn off all the IDUs. The operating mode of all IDUs must be the same.

4 Display Panel

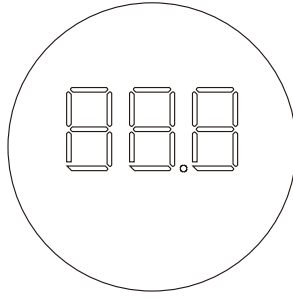

Display functions:

- ① In Standby mode, the main interface displays "----".
- ② When starting up in Cooling or Heating mode, the main interface displays the set temperature. In Fan mode, the main interface displays the indoor temperature. In Dry mode, the main interface displays the set temperature, and when the humidity is set, the set humidity value is displayed on the wired controller.
- ③ The light display on the main interface can be turned on or off through the light button on the remote controller.
- ④ When the system fails or runs in a special mode, the main interface displays the error code or the special mode running code. For more information, see the "Installation - Application Control - Error Codes and Meanings" section.

Caution

Some display functions are available only for certain IDU and ODU models, wired controllers, and display panels. For further details, please consult your local dealer or technical support staff.

Installation

Carefully read this manual before installing the IDU.

1 Installation Precautions

Qualification and Safety Regulation Requirements

Warning

Please carry out the installation according to local standards.

Ask your local dealer or professionals to install the product.

This unit must be installed by professional technicians with relevant specialized knowledge. Users MAY NOT install the unit themselves; otherwise, faulty operations may cause the risks of fire, electrical shock, injury, or leakage, which could harm you or others or damage the air conditioner.

Never modify or repair the unit on your own.

Otherwise, a fire, electric shock, injury or water leakage may occur. Get your local dealer or a professional to do so.

Ensure that the residual current device (RCD) is installed.

The RCD must be installed. Failure to install it may result in electric shock.

When powering the unit, follow the regulations of the local electric company.

Make sure that the unit is grounded reliably in accordance with laws. If the grounding is not completed correctly, it may cause electrical shock.

When moving, disassembling or reinstalling the air conditioner, get the assistance of your local dealer or a professional.

If installed improperly, fire, electrical shock, injury, or water leakage may occur.

Use the optional accessories specified by our company.

The installation of these accessories must be carried out by professionals. Improper installation may cause fire, electrical shock, water leakage and other hazards.

Use only power cables and communication cables that meet specification requirements. Properly connect all the wiring to make sure that no external forces are acting on the terminal blocks, power cables and communication cables. Improper wiring or installation may cause a fire.

The air conditioner must be grounded. Check whether the earth line is securely connected or broken. Do not connect the ground line to gas cans, water piping, lightning rods or telephone earth lines.

The main power switch of the air conditioner should be put in a position that is out of the reach of children.

It should not be obstructed by flammable objects such as curtains.

Open flames are prohibited when refrigerant leaks are present.

If the air conditioner is not cooling/heating properly, this may be caused by a refrigerant leak. If this occurs, contact your local dealer or a professional.

The refrigerant in the air conditioner is safe, and usually does not leak. If there is refrigerant leakage in the room, it is easy for a fire to occur after contact with the heating units of the heater/electric stove/stove. Please disconnect the power supply of the air conditioner, extinguish the flames of appliances that produce a flame, and open the windows and doors of the room to allow ventilation and ensure that the concentration of refrigerant leakage in the room does not exceed a critical level; keep away from the leakage point, and contact the dealer or professional personnel.

After the refrigerant leakage is repaired, do not start the product until the maintenance personnel confirms that the leakage is fully repaired.

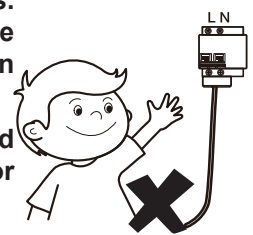
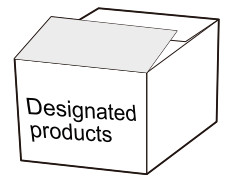
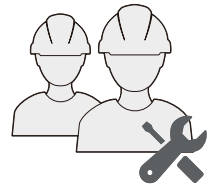

Before and after installation, exposing the unit to water or moisture will cause electrical short circuit.

Do not store the unit in a humid basement or expose it to rain or water.

Make sure the installation base and lifting are robust and reliable;

Insecure installation of the base may cause the air conditioner to fall, leading to an accident. Take into full consideration the effects of strong winds, typhoons and earthquakes, and reinforce the installation.

Check whether the drainage pipe can drain the water smoothly.

Improper installation of the pipeline may lead to water leakage that damage the furniture, electric appliances, and carpet.

After installation, check whether the refrigerant is leaking.

Do not install the product in a location where there is a danger of flammable gas leaks.

In the event of leakage of combustible gas, the combustible gas surrounding the IDU may cause a fire.

Install an air filter of 30–80 mesh/inch at the return air grille to filter dust in the air and keep the air diffuser clean and free from dirt blockage.

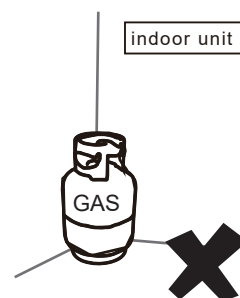

Caution

Keep the IDU, ODU, power cable, and connecting wires at least 1m away from the high-power radio equipment, to prevent electromagnetic interference and noise. For some electromagnetic waves, it is not enough to prevent noise even at a distance of more than 1m.

In a room equipped with fluorescent lamps (rectifier type or fast start type), the signal transmission distance of the remote controller (wireless) may not reach the predetermined value. Install the IDU as far away from the fluorescent lamp as possible.

Do not touch the fins of the heat exchanger, as this could cause injury.

For safety, please dispose of the packing materials properly.

Nails and other packaging materials may cause personal injury or other risks. Tear up the plastic packaging bag and dispose of it properly to prevent children from playing with it, leading to suffocation.

Do not cut off the power supply immediately after the IDU stops running.

Some parts of the IDU like the valve body and water pump are still in operation. Please wait for at least 5 minutes before cutting off the power supply. Otherwise, water leakage and other faults may occur.

For evaporating units and condensing units, the instructions or markings shall include a wording to assure that the maximum operating pressure is considered when connecting to any condenser unit or evaporator unit.

For evaporating units, condensing units and condenser units, the instructions or markings shall include refrigerant charging instructions.

A warning to assure that partial units shall only be connected to an appliance suitable for the same refrigerant.

This unit is a partial unit air conditioner, complying with partial unit requirements of this International Standard, and must only be connected to other units that have been confirmed as complying to corresponding partial unit requirements of this International Standard.

The electrical interfaces shall be specified with purpose, voltage, current, and safety class of construction.

The SELV connection points, if provided, are to be clearly indicated in the instructions.

The connection point should be marked with the “read the instructions” symbol per ISO 7000-0790 (2004-01) and the Class III symbol according to IEC 60417-5180 (2003-02).

Note

This unit is equipped with a refrigerant leak detector for safety. To be effective, the unit must be electrically powered at all times after installation, other than when servicing.

If any supplemental unit is employed to detect leaked refrigerant, such unit shall also apply this marking or be accompanied by such instructions.









Precautions for Carrying and Lifting the Air Conditioner

- ① Before carrying the air conditioner, determine the route that will be used to move it to the installation site.
- ② Do not unseal the air conditioner until it is moved to the installation site.
- ③ When unpacking and moving the air conditioner, do not apply force to the refrigerant piping, drainage pipe and plastic accessories, so as to avoid damaging the air conditioner and causing personal injury.
- ④ Before installing the air conditioner, make sure that the refrigerant specified on the nameplate is being used. For the installation of the ODU, refer to the installation instructions in the Installation & Owner's Manual attached with the ODU.

Forbidden Installation Sites

Warning

Do not install or use the air conditioner in the following places:

-  A place filled with mineral oil, fumes or mist, like a kitchen. Plastic parts will age and the heat exchanger will become dirty, eventually causing the air conditioner performance to deteriorate or leak water.
-  A place where there are corrosive gases, such as acid or alkaline gases. Copper pipes and copper welds will be corroded, resulting in refrigerant leakage.
-  A place exposed to combustible gases and using volatile combustible gases such as diluent or gasoline. The electronics in the air conditioner may cause the surrounding gas to ignite.
-  A place where there is equipment emitting electromagnetic radiation. The control system will fail and the air conditioner will not function properly.
-  A place where there is a high salt content in the air like a coastal area.
-  A place where an explosion may occur.
-  In vehicles or cabin rooms.
-  Factories with major voltage fluctuations in the power supplies.
-  Other special environmental conditions.



Caution

Air conditioner units of this series are designed to provide comfort. Do not use them in equipment rooms and rooms with precision instruments, food, plants, animals, or works of art.

Recommended Installation Sites

It is recommended to install the air conditioner according to the design drawing of the HVAC engineer. The selection principle for the installation site is as follows:

- Ensure that the airflow in and out of the IDU is reasonably organized to form an air circulation in the room.
- Ensure IDU maintenance space.
- The nearer the drainage pipe and copper pipe are to the ODU, the lower the pipe cost is.
- Prevent the air conditioner from blowing directly at the human body.
- The closer the wiring is to the power cabinet, the lower the wiring cost is.
- Keep the air-conditioning return air away from direct exposure to the sun in the room.
- Be careful not to interfere with the light tank, fire pipe, gas pipe and other facilities.
- The IDU should not be installed on load-bearing beams or columns that affect the structural safety of the house.
- The wired controller and the IDU should be in the same installation space; otherwise, the sampling point setting of the wired controller needs to be changed.

Choose a site that fully complies with the following conditions and user requirements to install the air conditioning unit:

- There is enough space for installation and maintenance.
- Airflow in/out of the machine is not obstructed, and the external air exerts minimum impact.
- It is easy to supply airflow to every corner of the room.
- It is easy to drain fluids from the connected piping and water discharge piping.
- There is no direct heat radiation.
- Avoid installation in narrow spaces or where there are more stringent noise requirements.
- Install the IDU at a place 2.5m above ground.
- Condensate water can be discharged smoothly.
- The length of the piping between the indoor and ODUs is within the permitted range. Refer to the Installation & Owner's Manual attached with the ODU.

Recommended Installation Sites



Crowded places such as living rooms and offices

The unit is usually installed in a concealed manner, with air supplied on the side and returned at the bottom.

The air outlet must not face areas where people frequently spend time, such as sofas and coffee tables. Instead, the breeze should flow out from the side to increase comfort.



Dining room

As the dining room is generally located next to the kitchen, which is usually filled with oily fumes, the central air conditioner can be installed on the ceiling between the dining room and the kitchen. The air outlet must not face the dining table. Otherwise, dust on the air outlet on the ceiling may be blown onto the food. Keep the return air inlet as far away from the kitchen as possible to avoid intaking oily fumes and affecting the air quality.



Bedroom

The unit can be installed on the ceiling above the bedroom doors or near windows. The air is flexibly supplied on the side and returned at the bottom. Avoid directing streams of air towards the bed if possible.

Warning

Install the air conditioner in a location with sufficient strength to support the weight of the unit. Take reinforcement measures when necessary.

The unit may fall and cause personal injury if the location is not strong enough or if the air conditioner is not properly installed.

Before wiring/pipe layout, make sure that the installation area (walls and floor) is safe and free of water, power, gas, and other hidden dangers.

The unit needs to be level and shall not tilt to either side or forward.

Parts

Part Description (kW≤8.0)

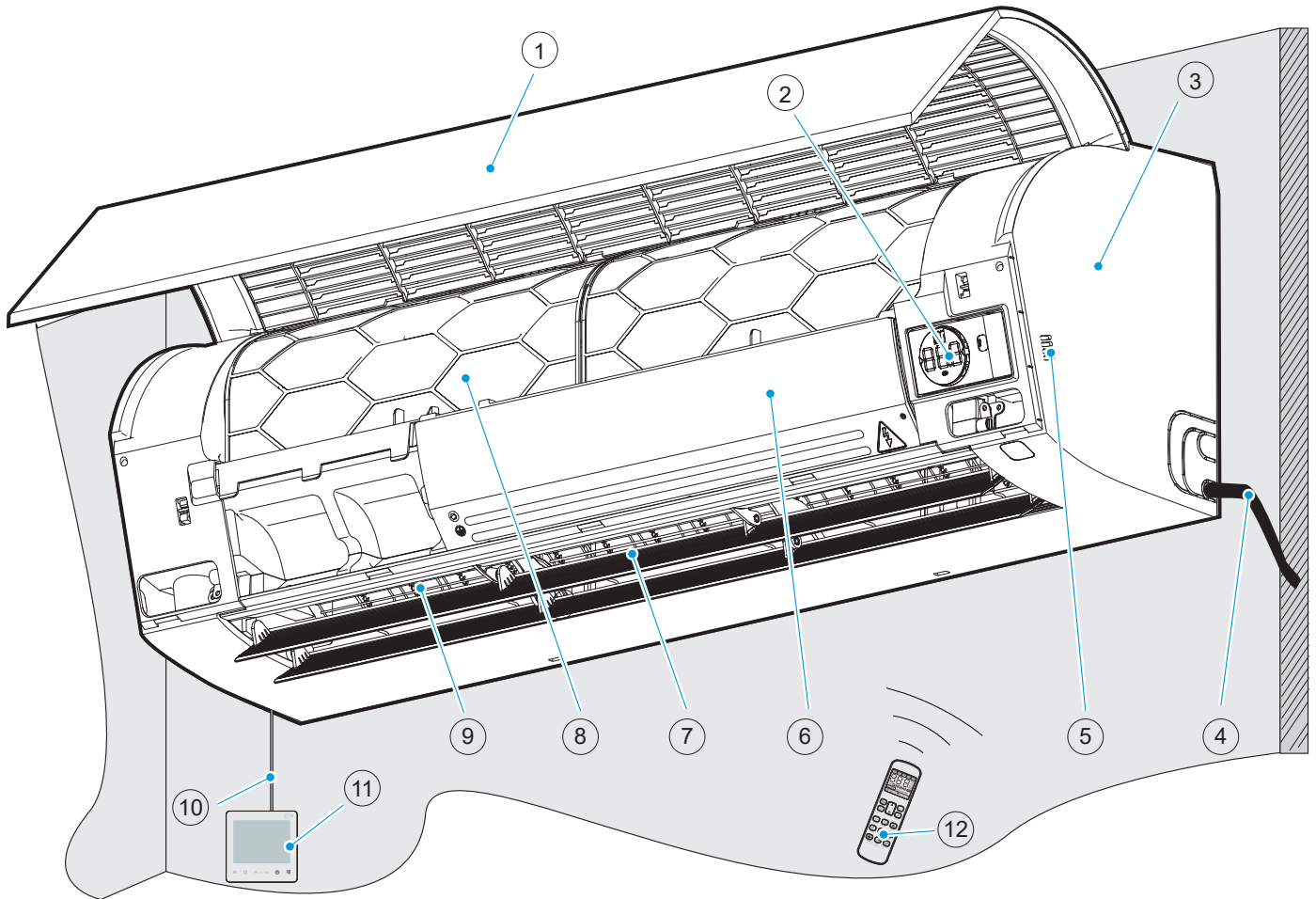

① Panel assembly

② Display panel

③ Panel frame

④ *Power cable and ground wire

⑤ Room temperature sensor

⑥ Electric control parts

⑦ Upper and lower louvers

⑧ Filter

⑨ Left and right louver parts (optional)

⑩ *Connection wire

⑪ Wired controller (optional)

⑫ Remote controller (optional)

* To be purchased separately on site.

Note

When installing the unit, remember to remove the protective film of the display panel and sticker attached, otherwise the display effect will be affected.

All the optional accessories should be from our company.

For optional accessories such as wired controllers, please refer to the instructions of the product.

All the figures in the manual explain only the general appearance and functions of the product. The appearance and functions of the product you purchased may not be completely consistent with those listed in the figures. Please refer to the actual product.

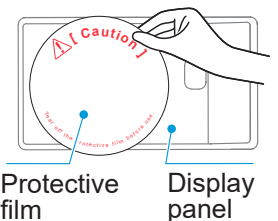

2 Product Installation

(Unit: mm)

Product Dimensions

kW≤8.0:

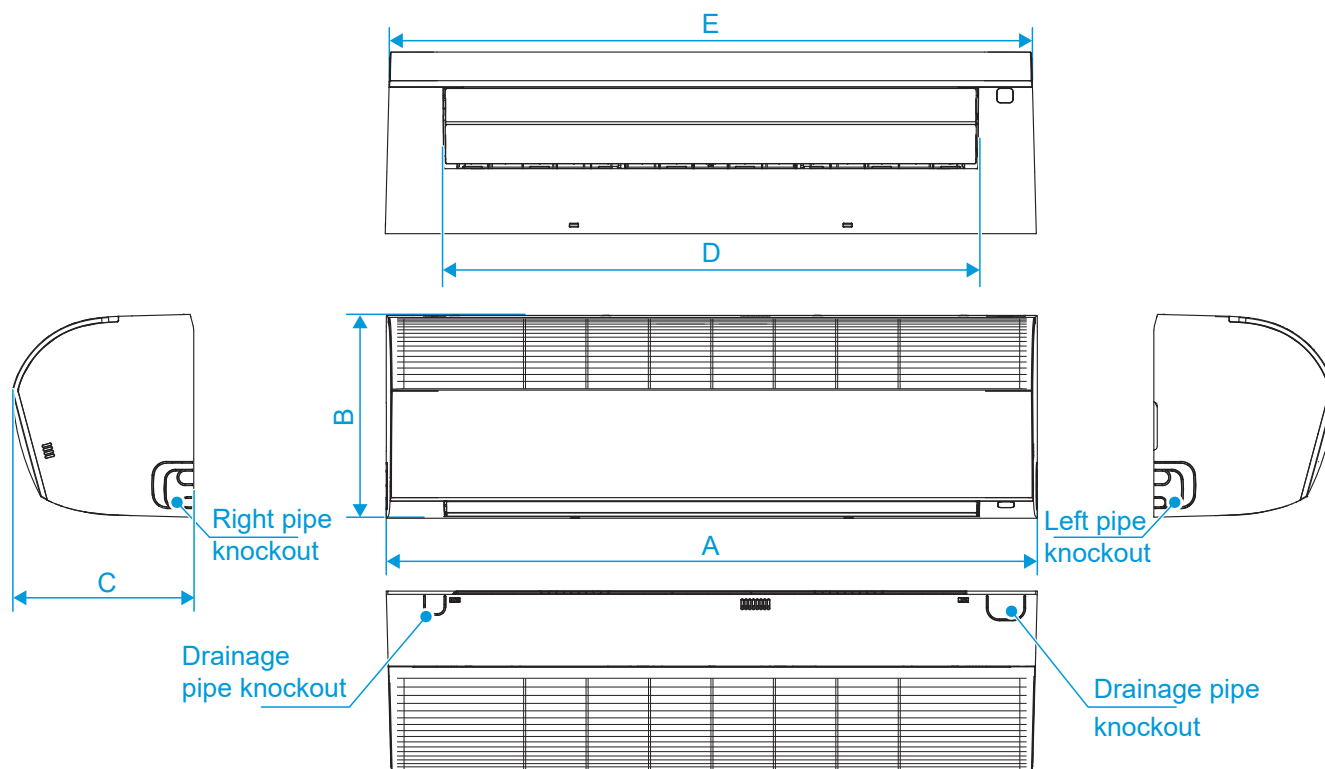

Model (kW)	A	B	C	D	E
kW≤3.6	750	295	265	581	736
3.6 < kW≤5.6	950	295	265	781	936
5.6 < kW≤8.0	1200	295	265	1025	1186

Installation Distance

kW≤8.0:

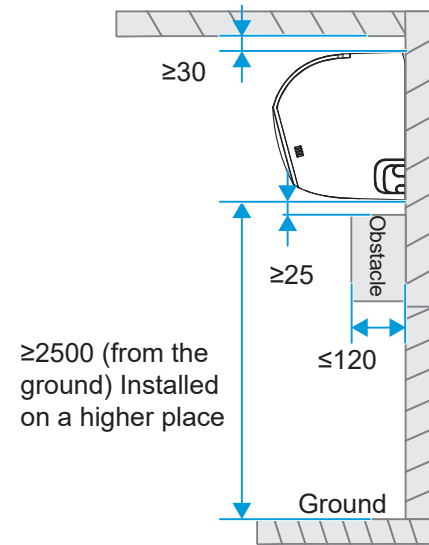
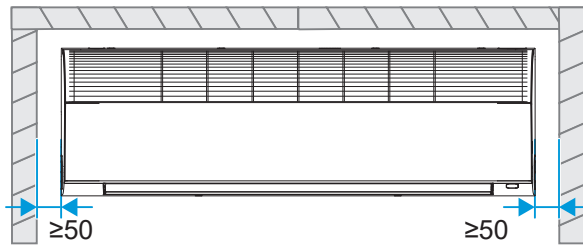

Pipe Routing Direction

The refrigerant pipe can be routed from four directions: left, left rear, right, and right rear; drainage pipe can be routed from six directions: left, left rear, right, right rear, upper left, and upper right. The upper left and upper right directions are only applicable to drainage pipe of the water pump.

If pipes are routed from left, right, upper left or upper right directions, cut holes through the panel frame accordingly.

Refrigerant pipe routing direction

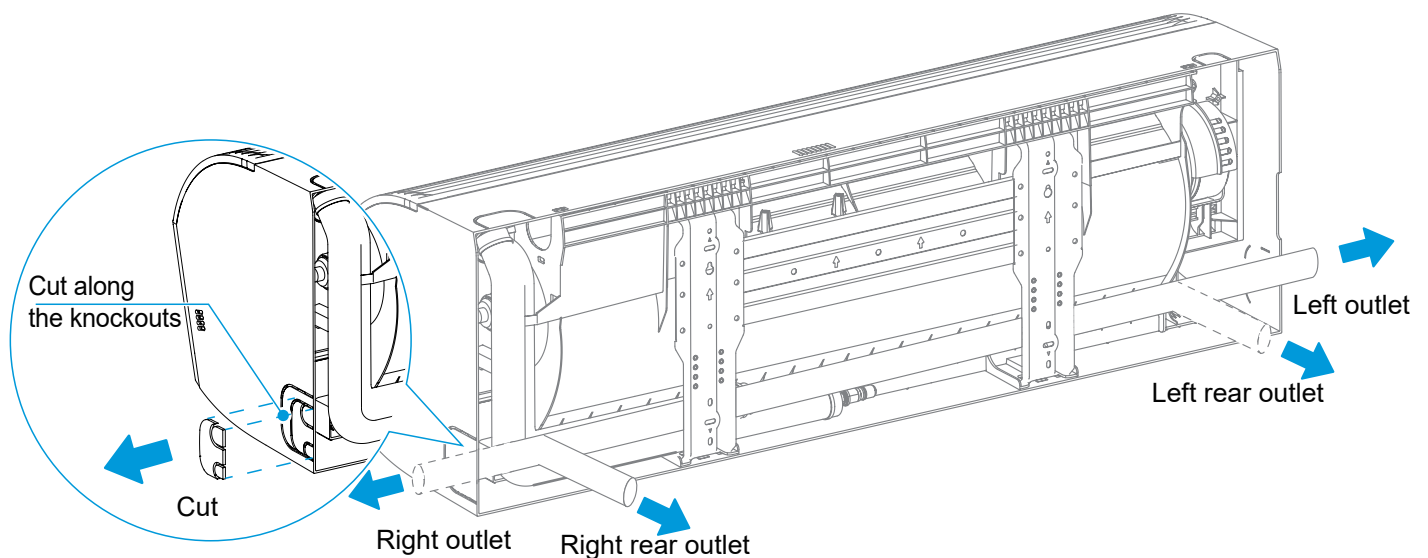

Drainage pipe routing direction

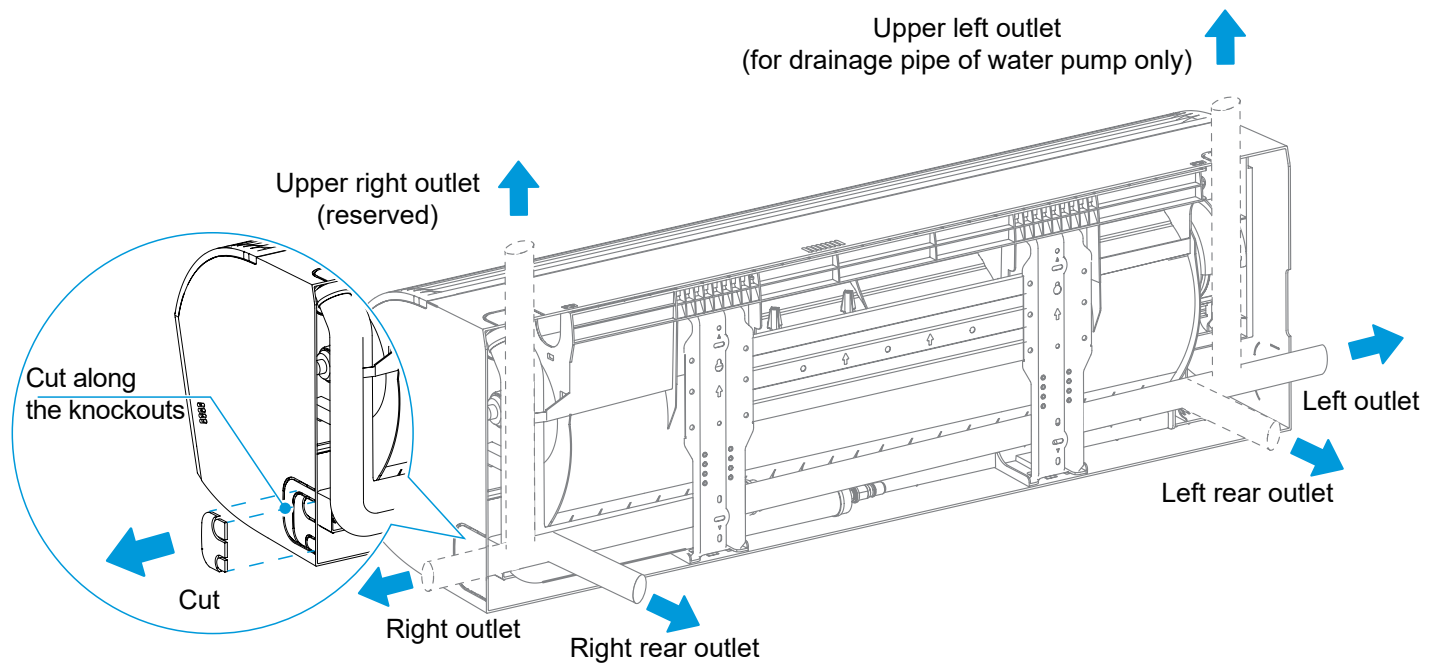

Instructions on Cutting Left and Right Knockouts

kW≤8.0:

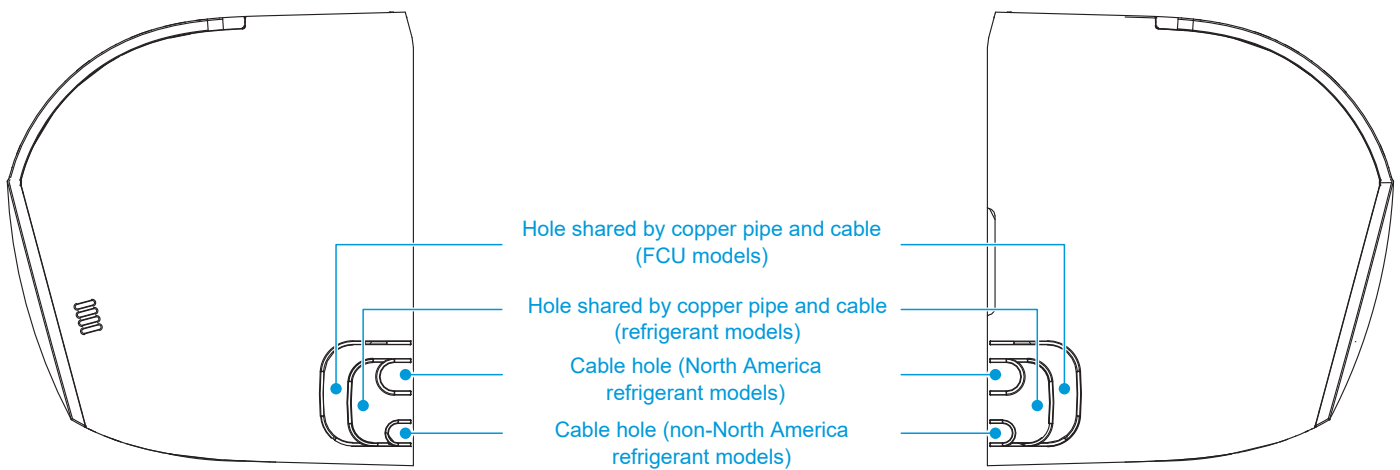

Installation Board Positioning

kW≤8.0

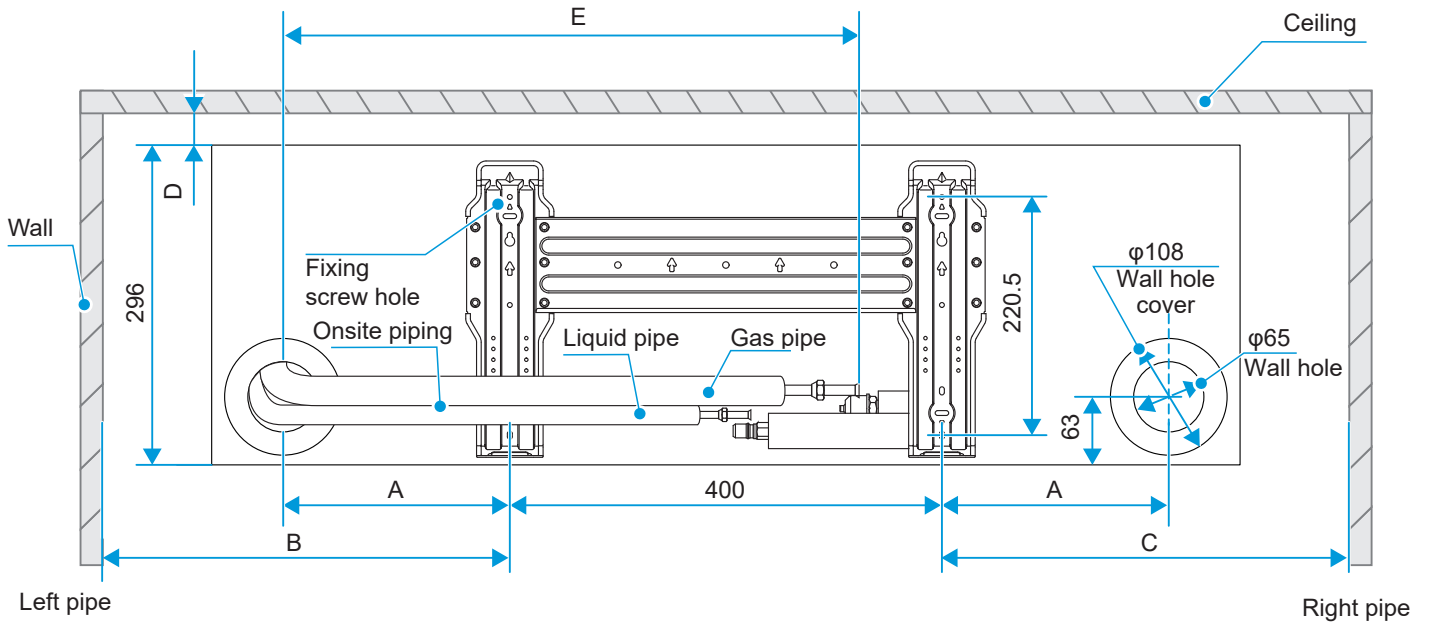

Distance Model (kW)	A	B	C	D	E	Reserved length of power cable and signal cable	
						Left pipe	Right pipe
kW≤3.6	100	≥225	≥225	≥30	230	≥1115	≥415
3.6<kW≤5.6	180	≥325	≥325	≥30	412	≥1315	≥415
5.6<kW≤8.0	220	≥375	≥375	≥30	530	≥1565	≥415

Installation Materials

1 Accessories

List of accessories				
Installation & Owner's Manual X 1 IDU Installation Instructions (Make sure to hand it over to the user)	Brass nut X 2 For use in the installation of connecting pipe	Drainage hose X 1	Installation board X 1	Rubber sleeve of expansion screw X 4
Wall hole sleeve X 1	Wall hole sleeve cover X 1	Binding tie X 1	Power cable clamp X 2	Screw ST3.9*25 X 4
Screw ST3.9*6.5 X 4				

Note

- Check the accessory kit for the above items and contact your local dealer for any missing items.
- Do not throw away any accessories that may be required for installation until the installation is complete.
- Wired/remote controller is optional and needs to be purchased separately.

2 Locally Purchased Accessories

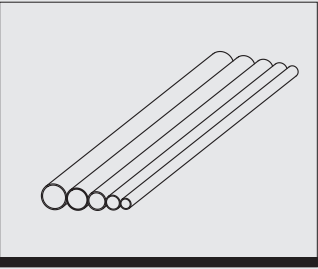
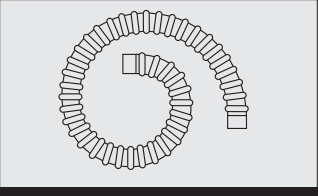
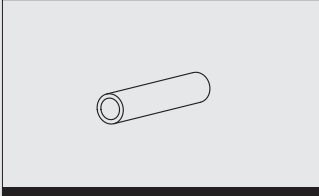
	Connecting piping (unit: mm)		
	Capacity	Piping	Gas side
	kW≤5.6	Φ6.35×0.75	Φ12.7×0.75
	5.6 < kW≤8.0	Φ9.52×0.75	Φ15.9×1.0
	Remarks	For connection of the IDU refrigerant system, it is recommended to use a soft copper tube (T2M), with the length selected according to the actual situation.	
	Drainage hose		Thermal insulation pipe
	This is used to extend the IDU's drainage pipe, 16mm in external diameter. The length is determined according to actual needs.		The thickness of the insulation pipe for the copper pipe is usually 15mm or above; and the thickness of the insulation pipe for the UPVC plastic tube is usually 10mm or above. If the pipe is used in a closed humid area, the thickness should be increased.

Caution

- Materials, including copper pipes, drainage hoses, various fasteners (such as pipe supports, clamps, and screws), power cables, and signal cables to be used for field installation need to be purchased on site by the installation operator.
- Materials and specifications must comply with relevant national or industry standards.

3 Heat Insulation Material Requirements

Copper pipe insulation

- ① Use the closed-cell foam insulation material, which is rated at a flame retardancy level of B1 and heat resistance of over 120 °C.
- ② Thickness of the insulation pipe:
 1. When the diameter of the copper pipe is equal to or greater than 15.9mm, the insulation thickness is at least 20mm.
 2. When the diameter of the copper pipe is equal to or smaller than 12.7mm, the insulation thickness is at least 15mm.
- ③ For insulation of the outdoor copper pipe, the wall thickness of insulation pipes for winter heating systems is generally thickened to over 40mm in regions with severe cold. For insulation of the indoor gas pipe, the wall thickness of insulation pipes is usually greater than 20mm.

Caution

The materials and specifications of insulation materials must meet national or industry standards.

Installation Operation

1 Check Before Installation

Unpacking Check

- ① Before installation, check whether the packing materials are in good condition, whether the accessories that come with the product are complete, whether the air conditioner is intact, whether the surfaces of the heat exchanger and other parts have become worn, and whether there are oil stains on the check valve of the unit.
- ② Check the two sealing nuts of the refrigerant pipe, and observe whether the red dot on the surface of the sealing nut of the gas pipe bulges. If it bulges, the pipe is well sealed; if it retracts, the line is leaking, and you need to contact your local dealer.
- ③ Check the machine model before installation.
- ④ After IDU and ODU inspection, pack them with plastic bags to avoid intake of foreign matters.

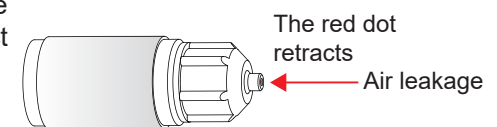
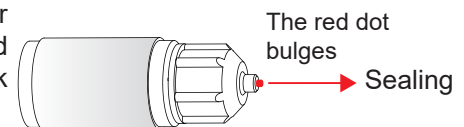

Refrigerant Connecting Piping Installation

1 Length and Level Difference Requirements for the Pipe Connections of IDU and ODU

Different ODUs have different requirements for length and level differences for the piping. Refer to the Installation & Owner's Manual attached with the ODU.

Warning

During the installation of the connecting pipes, do not allow air, dust, and other debris to penetrate the piping system, and make sure the interior of the pipes is dry.

Install the connecting pipes only when the IDUs and ODUs are secured.

When installing the connecting pipes, record the actual installation length of the liquid pipe on the spot so that additional refrigerant can be added.

The copper pipes must be wrapped with thermal insulation materials when they are installed.

In the event of refrigerant gas leakage during operation, please ventilate immediately.

2 Pipe Layout

- ① Bend the pipes or punch holes in the wall as needed. The deformed pipe area must not exceed 15% of the total area. A protective casing should be installed at the wall or floor hole. The weld joint must not be inside the casing. The drill hole on the external wall must be sealed and tightly wrapped with a binding tie to prevent impurities from entering the pipe. The pipe must be insulated with the correctly-sized insulation pipe.

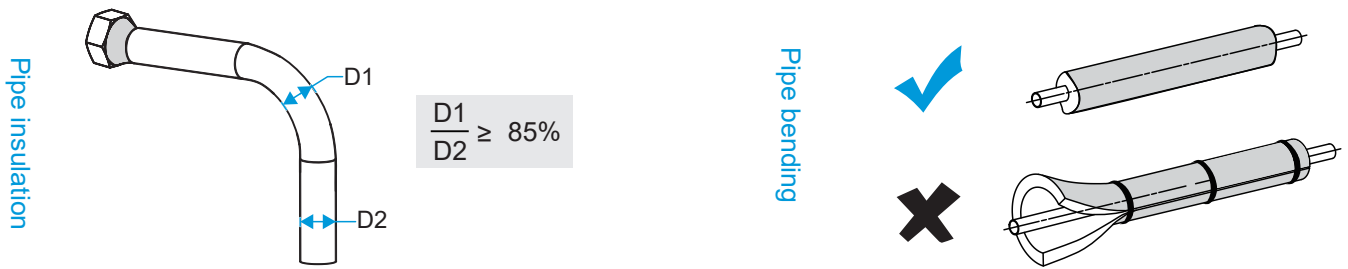

Note: D1 is the minimum diameter, and D2 is the nominal diameter.

- ② The wrapped connecting pipe is plugged through the wall hole sleeve from the outdoor side and enters the indoor side. The pipes must be arranged carefully so as not to damage the piping.

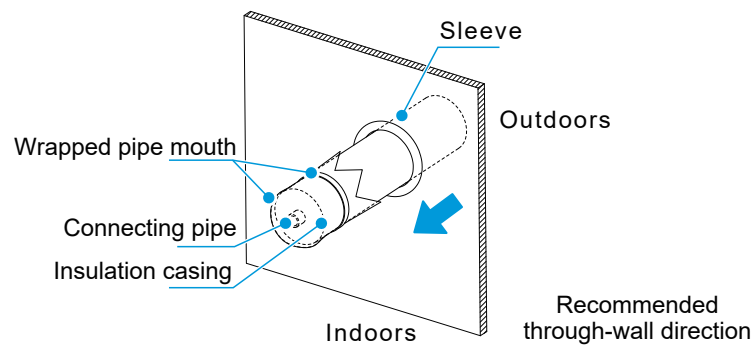

3 Pipe Connection Steps

Measure the required length of the connecting pipe. Make the connecting pipe using the following method (see "Pipe Connection" for details).

- Connect the IDU first, then connect the ODU.
- ① Before tightening the flare nut, apply refrigeration oil on the inner and outer surface of the pipe flare (you must use refrigeration oil compatible with the refrigerant for this model), and tighten it 3 or 4 turns by hand. When connecting or removing a pipe, use two wrenches at the same time.

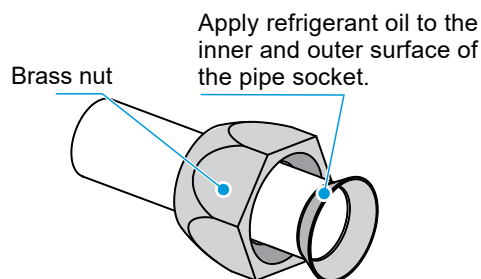

⚠ Caution

Bend and arrange pipes carefully without damaging the pipes and their insulating layers.

Do not let the interface of the IDU bear the weight of the connecting pipe; otherwise, the connecting pipe may be crushed and deformed, which will affect the cooling (heating) effect, or the thermal insulation materials may be compressed, resulting in air leakage and condensation.

- ② The check valve of the ODU is completely closed when leaving the factory. Unscrew the nuts from the check valve in each connection, and connect the flared tube within 5 minutes. When the nuts at the check valve are removed and placed somewhere for too long, dust and other sundries may enter the pipeline system and cause failures after extended operation.
- ③ After the refrigerant piping is connected to the IDU and ODU, follow the operations in "Vacuum pumping" to exhaust the air. After the air is exhausted, tighten the maintenance nut.

4 Pipe Connection

Processing method

Mechanical bending processing: Wider application ($\phi 6.35$ - $\phi 28.6$ mm), using a spring pipe bender, manual pipe bender or electric pipe bender.

⚠ Caution

When bending pipes, the copper pipes shall not be wrinkled or deformed on the inside.

When a spring pipe bender is used, clean it before it is inserted into the copper pipe.

The bending angle should not exceed 90° ; otherwise, wrinkles will form in the pipe, which increases the likelihood of breakage.

Do not leave any dents in the pipe when you bend the pipe. The cross-sectional area of the bent pipe must exceed $2/3$ of the original pipe section.

1. Brazing pipes

When brazing pipes, fill the pipes with nitrogen. First evenly heat the inner pipes, then the outer pipes, and fill the joints with welding material.

⚠ Caution

Nitrogen pressure is kept at about 0.2 – 0.3 kgf/cm² during welding.

Use nitrogen for welding. Do not use flammable gas such as oxygen to avoid the risk of explosion.

Use a pressure relief valve to keep the nitrogen pressure at 0.2 kgf/cm².

Select an appropriate position to add nitrogen.

Make sure that the nitrogen passes the welding spot.

If there is a long distance between the position of adding nitrogen and the welding spot, keep adding the nitrogen for a while until oxygen at the welding spot is completely removed.

After welding is completed, continue adding nitrogen until the pipe becomes cool.

Perform welding downwards or horizontally from either side.

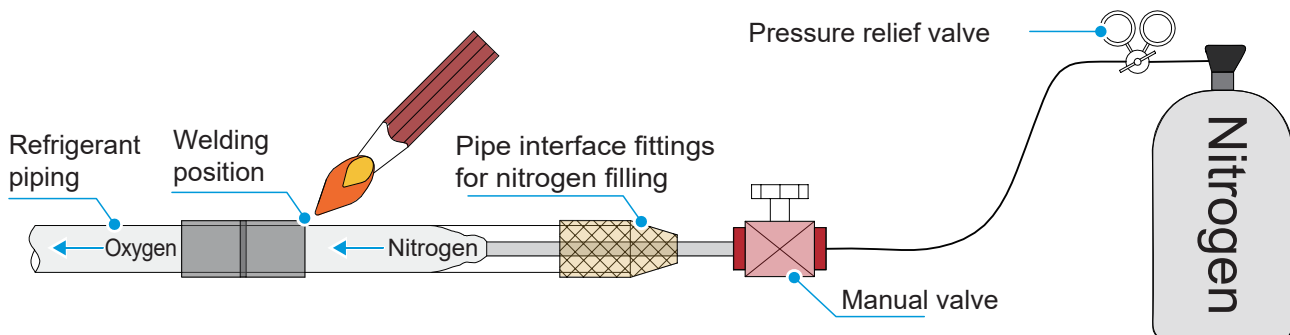

2. Flaring

To cut the piping with a pipe cutter, rotate the pipe cutter repeatedly.

Put the pipe into the connecting nut flaring, and both the gas pipe and liquid pipe of the IDU are connected by flaring.

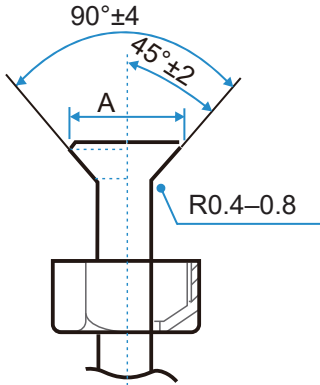
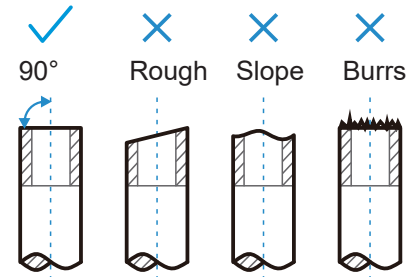
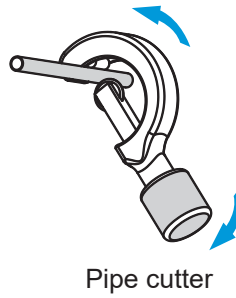

Outer diameter (mm)	A (mm)	
	Max.	Min.
Φ6.35	8.7	8.3
Φ9.52	12.4	12.0
Φ12.7	15.8	15.4
Φ15.9	19.1	18.6
Φ19.1	23.3	22.9

3. Nut fastening

- Align the connecting piping, firstly tighten most of the thread of the connecting nut by hand, and then use a wrench to tighten the last 1-2 turns of the thread as shown in the figure.
- The welding is done on site, and the bell mouth cannot be used indoors. (For IEC/EN 60335-2-40 except IEC 60335-2-40: 2018)
- The protective nut is a one-time part, it can not be reused. In case it is removed, it should be replaced with a new one. (For IEC 60335-2-40: 2018 only)

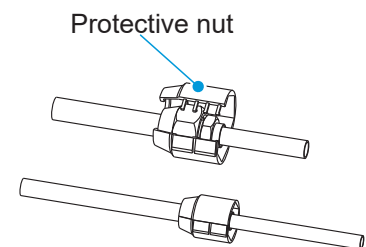
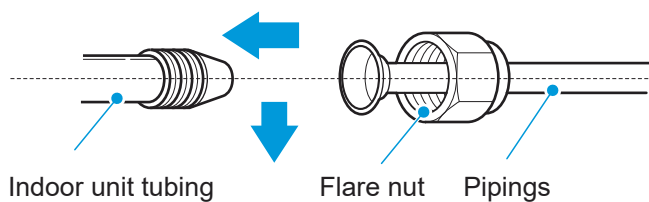
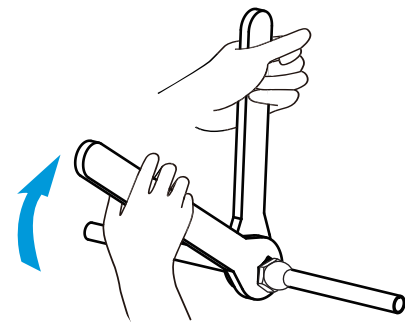
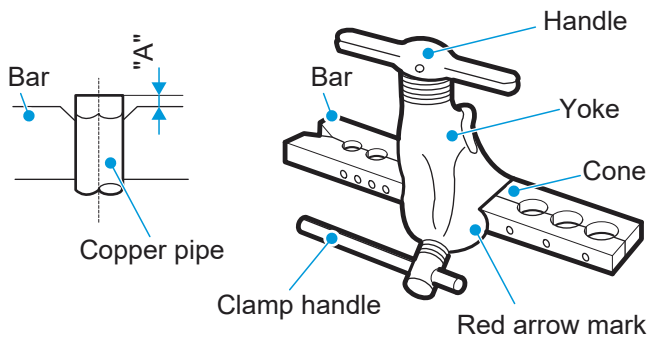

⚠ Caution

Excessive torque can break nut on installation conditions.

When flared joints are reused indoors, the flare part should be re-fabricated.

Pipe size (mm)	Tightening torque [N.m (kgf.cm)]
Φ6.35	14.2–17.2 (144–176)
Φ9.52	32.7–39.9 (333–407)
Φ12.7	49.5–60.3 (504–616)
Φ15.9	61.8–75.4 (630–770)
Φ19.1	97.2–118.6 (990–1210)

Caution

Depending on the installation conditions, excessive torque will damage the flared mouth, and too small torque cannot tighten the nut, which will cause refrigerant leakage. Please refer to the above table to determine the appropriate tightening torque.

5 Refrigerant Piping Fixing

Angle iron brackets or round steel hangers should be used for fixing. When the liquid pipe and gas pipe are suspended together, the size of the liquid pipe shall prevail.

Outer diameter of copper pipe (mm)	≤20	20~40	≥40
Horizontal pipe distance (m)	1.0	1.5	2.0
Stand pipe distance (m)	1.5	2.0	2.5

6 Vacuum Pumping

Connect the refrigerant piping to the gas and liquid pipes of the ODU, and use a vacuum pump to evacuate the gas and liquid pipes of the ODU at the same time.

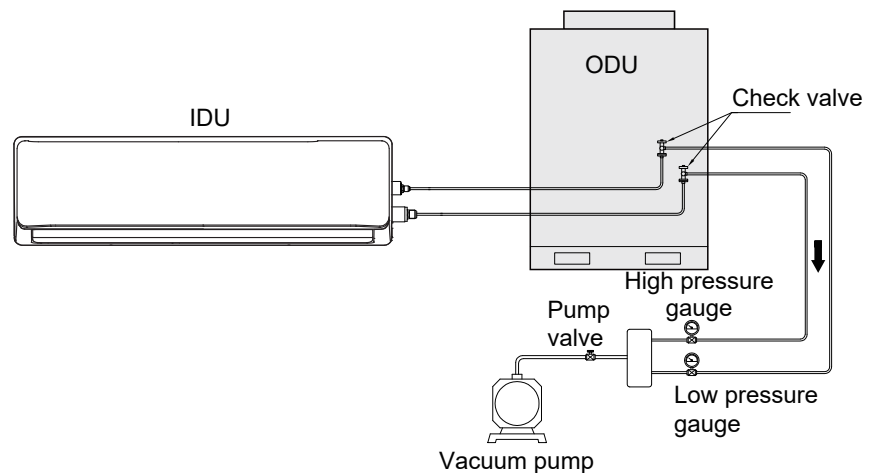

Caution

Do not use the refrigerant enclosed in the ODU for vacuuming. The reduction of ODU refrigerant may cause performance degradation of the air conditioner.

7 Leak Detection

Fill the system with nitrogen and increase its pressure to detect leaks. The following methods are recommended:

1. By foam

Apply soapy water or foam evenly (spray) on areas where leakage may occur, and observe whether air bubbles appear. If there are no air bubbles, it indicates that the system is airtight.

2. By instrument

Use a refrigerant leak detector to identify leaks. Align the leak detector probe with the part where leakage may occur, and follow the instructions to determine whether there is a leak.

Caution

Leak detection will be conducted at each spot for at least 3 minutes. If any leak has been identified, tighten the nut and perform the detection again until no leaks are found. After completing the leak detection, wrap the exposed IDU pipe joint with insulation material and tie it with a binding tie to prevent condensation and dripping water.

8 Heat Insulation Treatment

Pipes the liquid and air sides have a low temperature during cooling. Take sufficient insulation measures to prevent condensation.

Caution

Be sure to use a thermal insulation material with a heat resistance of 120°C or higher for the gas pipe.

The attached insulation material for the part of the IDU where the pipe connects must undergo heat insulation treatment that leaves no gaps.

Thermal insulation materials directly exposed to the open air will degrade and lose their insulating properties. For outdoor pipelines, additional protective treatments should be performed, such as adding metal duct boxes.

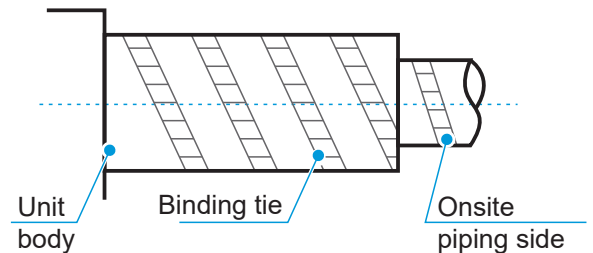

1. Steps of insulating refrigerant piping



Connecting parts: For example, brazing area, flare, or flange connection shall be insulated after passing the air tightness test.

2. Reasons why refrigerant piping shall be insulated

- (1) The gas pipes and liquid pipes can become extremely hot or cool while in operation. Therefore, they should be insulated. Otherwise, the cooling and heating effects will be seriously impacted, and the compressor may become burnt.
- (2) The gas pipes are cold when the unit operates in cooling mode. If they are not properly insulated, they may cause condensation and water leakage.
- (3) The outlet pipe (gas pipe) is hot (usually 50–100°C) when the unit operates in heating mode, and accidental contact with the pipe will cause burns. To avoid burns, the pipes should be insulated.

3. Selection of insulation materials for refrigerant piping

Use the closed-cell foam insulation material, which has a flame retardant level of B1 and heat resistance of over 120°C.

4. Thickness of the insulation layer

When the outer diameter d of the copper pipe is not greater than $\Phi 12.7\text{mm}$, the thickness δ of insulation layer is greater than 15mm.

When the outer diameter d of the copper pipe is not smaller than $\Phi 15.9\text{mm}$, the thickness δ of insulation layer is greater than 20mm.

Caution

The above thickness should be increased if the place is hot and humid.

The pipes outdoors should be protected by metal covers to avoid sunlight, rain, weathering, external force or artificial damage.

5. Installation and insulation tips

(1) Wrong

The gas pipe and the liquid pipe are insulated together, which reduces the heating or cooling effects.

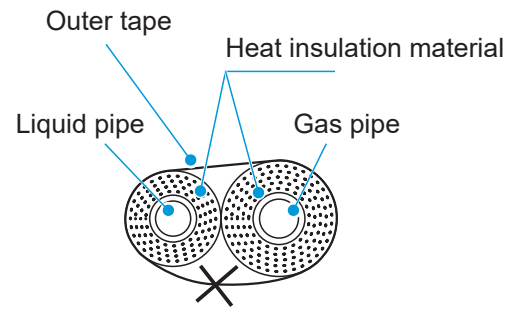

Pipes should not be bound together.



(2) Correct

a. Insulate the gas pipe and the liquid pipe separately.

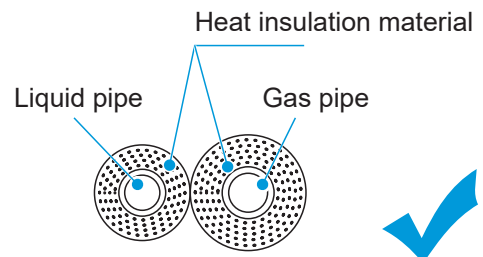

! Caution

After the gas pipe and the liquid pipe are insulated separately, binding them too tight may damage the insulation materials already connected. Binding with ties is not recommended.

b. Pipe connectors shall be properly insulated.

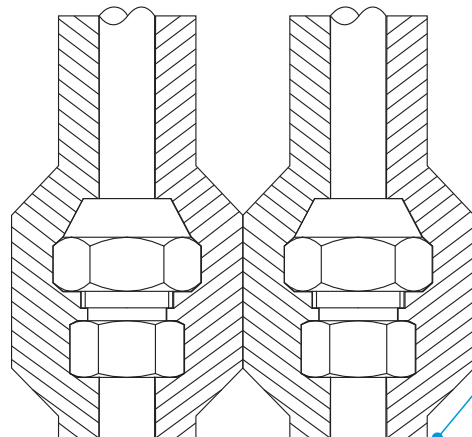

No gaps shall be left here

Unit

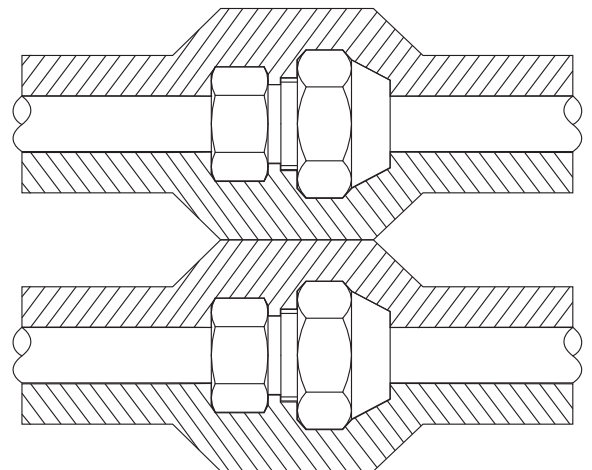

! Caution

No gaps shall be left at the place where insulation materials connect.

If the connecting sections of insulation materials are pulled too much, or wrapped too tightly, these sections are likely to shrink and leave gaps, causing condensation and dripping. Tight wrapping may squeeze out the air in the materials and reduce the insulation effects. In addition, the adhesive tape tends to age and peel off over time.

There is no need to wrap the concealed sections indoors with a binding tie, otherwise the insulation effect will be reduced.

Steps to repair protection sponge: (see the figure below)

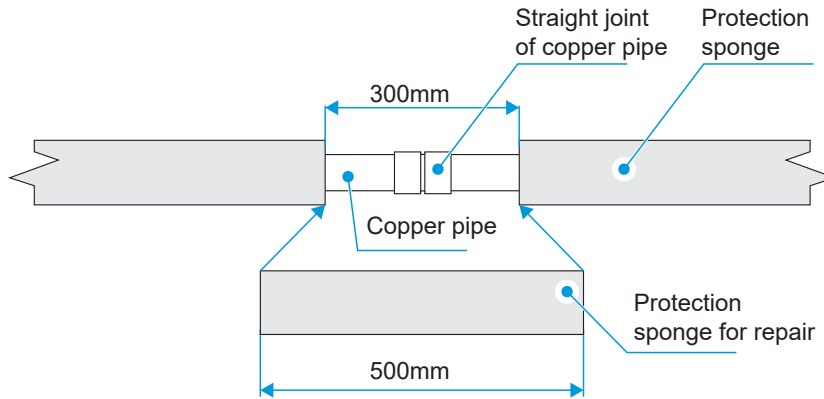

Cut a section of protection sponge longer than the gap, pull open the two ends, insert the protection sponge, and apply glue to the joint.

Caution

Tips for repairing insulation layer:

1. The length of the protection sponge for repair (protection sponge used to fill the gap) must be 5–10 cm longer than the gap.
2. The protection sponge for repair must be cut neatly.
3. Tightly insert the protection sponge for repair into the gap.
4. All the sectional areas and cuts must be glued.
5. Wrap the joints with tape.
6. There is no need to wrap the concealed sections with a binding tie, otherwise the insulation effect will be reduced.

Caution

When installing the insulation pipe on site, please cut it according to the actual needs. (Either method (a) or (b) is OK. Method (c) is incorrect. There must be no gap between the insulation pipe and copper pipe.)

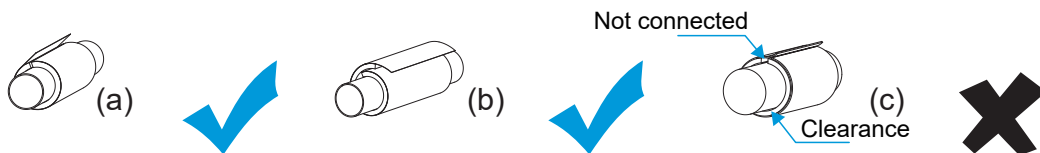

Installation of Drainage Hose

⚠ Caution

Before installation of the condensate pipeline, determine its direction and elevation to avoid intersection with other pipelines to ensure that the slope is smooth and straight.

The highest point of the drainage pipe should be equipped with a discharge port to ensure the smooth discharge of condensate water, and the discharge port must face downwards to prevent dirt from entering the pipe.

Do not connect the drainage pipe to the wastewater pipe, sewage pipe, or other pipes that produce corrosive gases or odors. Otherwise, the IDU (especially the heat exchanger) may be corroded and odor may enter the room, negatively impacting the heat exchange effects and user experience. The user will assume responsibility for any consequences resulting from failure to abide by instructions.

After the pipeline connection is completed, a water test and a full water test should be done to check whether the drainage is smooth and whether the pipeline system leaks.

The air conditioner drainage pipe must be installed separately from other sewage pipes, rainwater pipes and drainage pipes in the building.

Adverse slope, convex and concave pipes are prohibited, as improper airflow will cause poor drainage.

Drainage hoses need to be evenly wrapped with thermal insulation pipes to prevent condensation.

Please connect the drainage pipes in the following ways. Improper installation of the pipes may result in water leakage and damage to furniture and property.

All joints of the drainage system must be sealed to prevent water leakage.

1 Install the drainage hose.

- ① Connect the drainage hose to the water outlet pipe of the IDU.
- ② Wrap the joint with waterproof tape, cover the exposed drainage hoses with insulation material, and tie them with a binding tie.
- ③ Insert the end of the drainage hose outdoors into the drainage pipe.

💡 Note

The drainage hose is at the outer layer of the IDU drainage pipe. Try to connect the two pipes till the end.

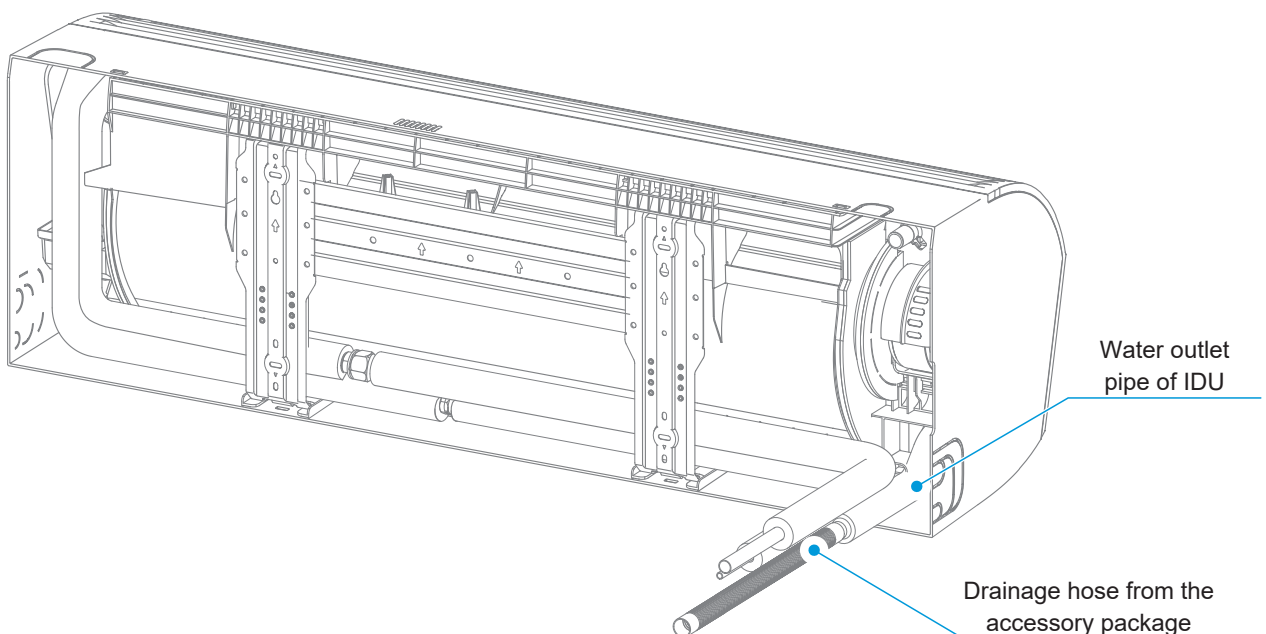

① Selection of drainage outlet

kW≤8.0:

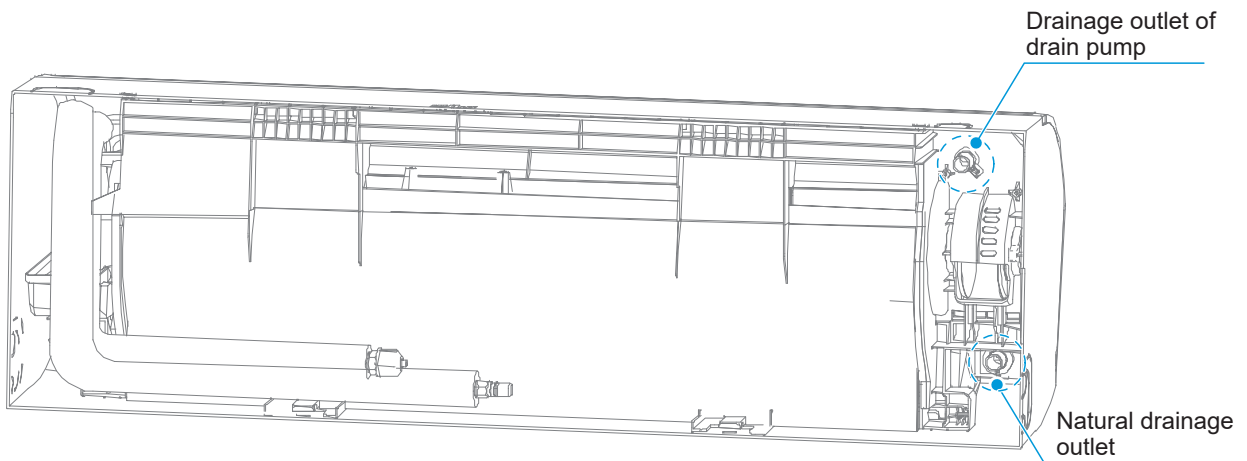

⚠ Caution

For models without drain pumps, a water outlet pipe is connected to the natural drainage outlet when the unit leaves factory. For models with drain pumps, a water outlet pipe is connected to the drainage outlet of the drain pump, with natural drainage outlet sealed using a drainage plug, when the unit leaves the factory. Models with drain pumps need to be customized.

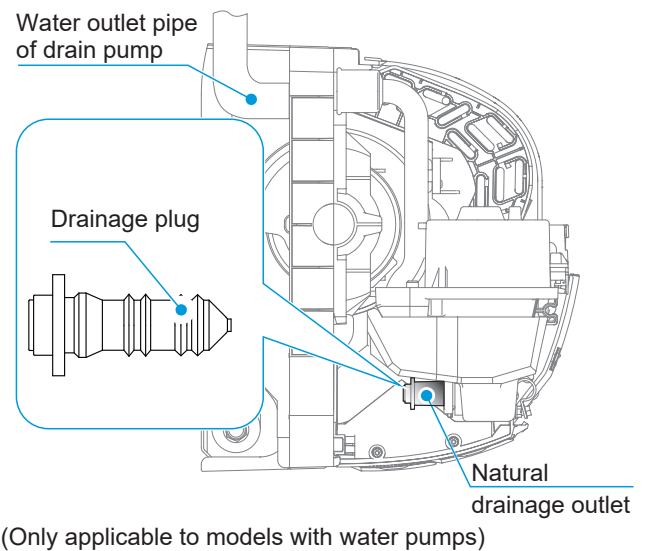

② Connection method of the drainage pipe

(Unit: mm)

- Method to discharge water with the natural drainage outlet:

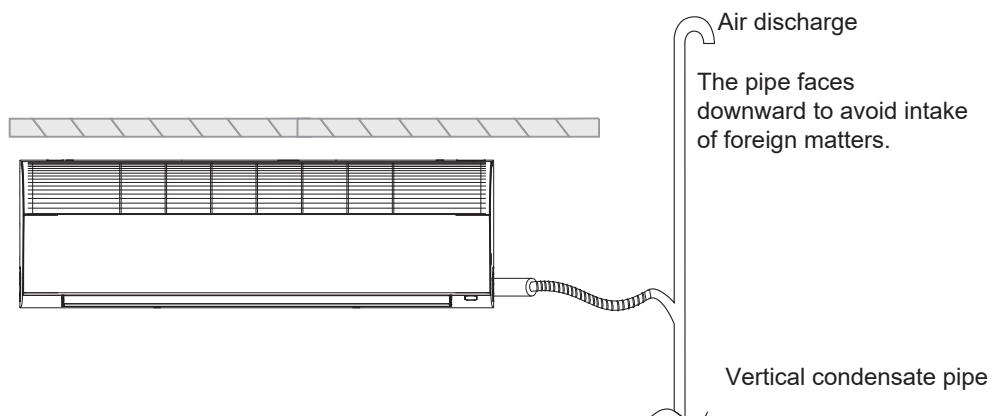

- Method to discharge water with the drain pump:

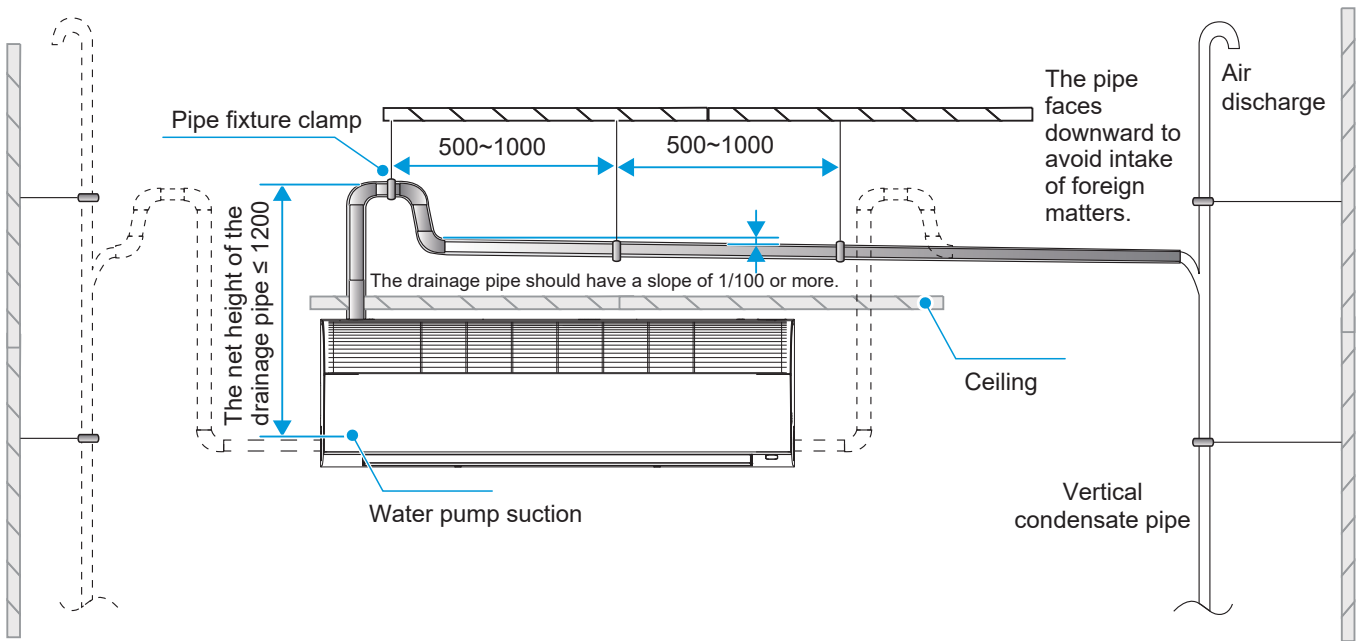

⚠ Caution

Requirements for slope of the drainage pipe:

- ① The branch pipes of the drainage pipe shall have a slope of at least 1% that follows the direction of water flow. Lifting bolts shall be placed every 1–1.5m at a horizontal pipe and every 1.5–2.0m at a vertical pipe. Each vertical pipe shall have at least two fixing points for branch pipes and lifting bolts.
- ② Adverse slopes are prohibited, and no water may accumulate in the elbow pipe. The outlet end shall not be immersed in liquid.

③ Installation requirement for drainage pipe

The drainage pipe must be inclined downward (1/100 or above) to avoid condensate water flow.

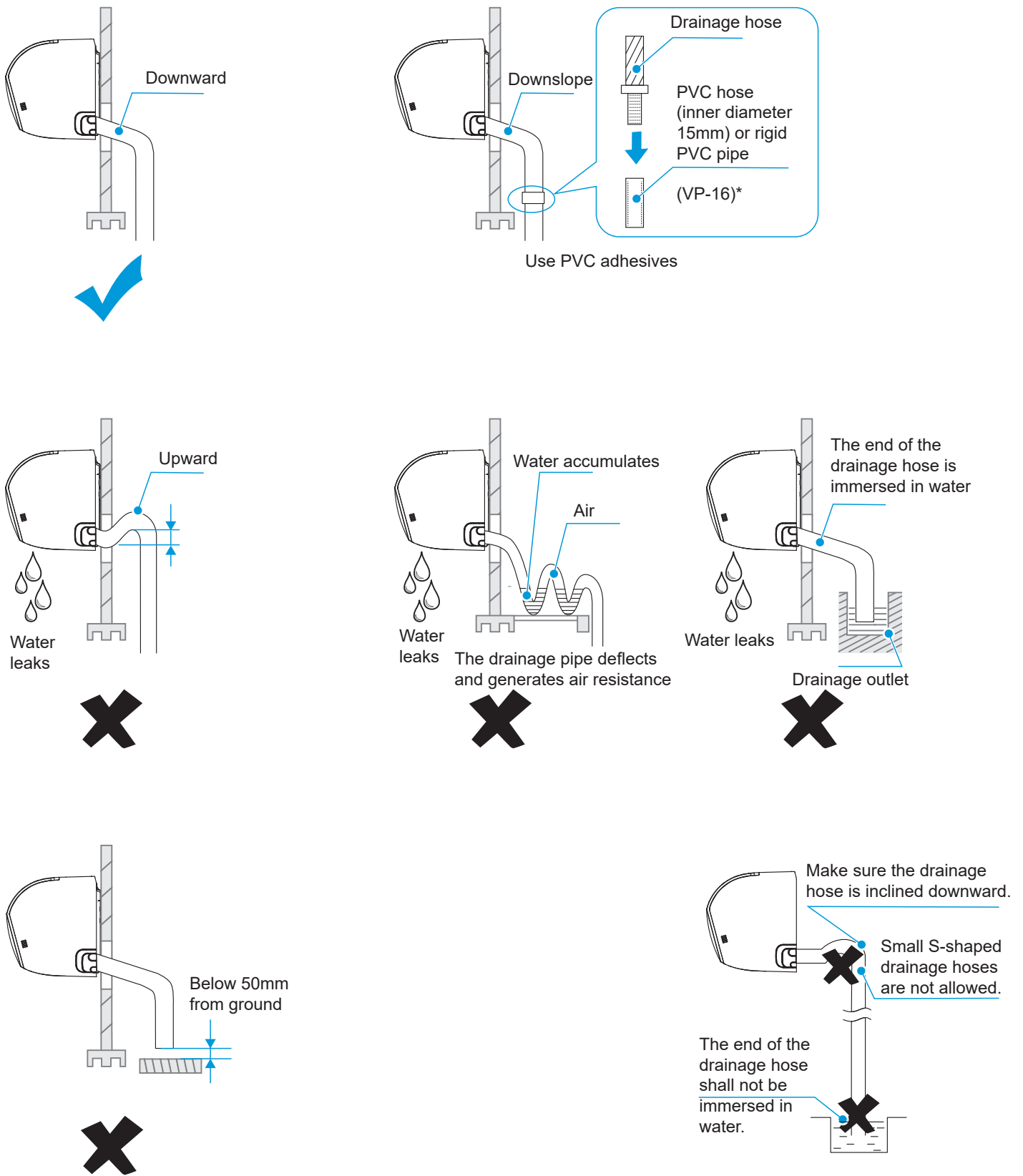

2 Extend the drainage pipe.

- ① To extend the length of a drainage pipe, you need to purchase an extension drainage hose locally. Make sure the extension portion of the drainage hose indoors undergoes heat insulation treatment.

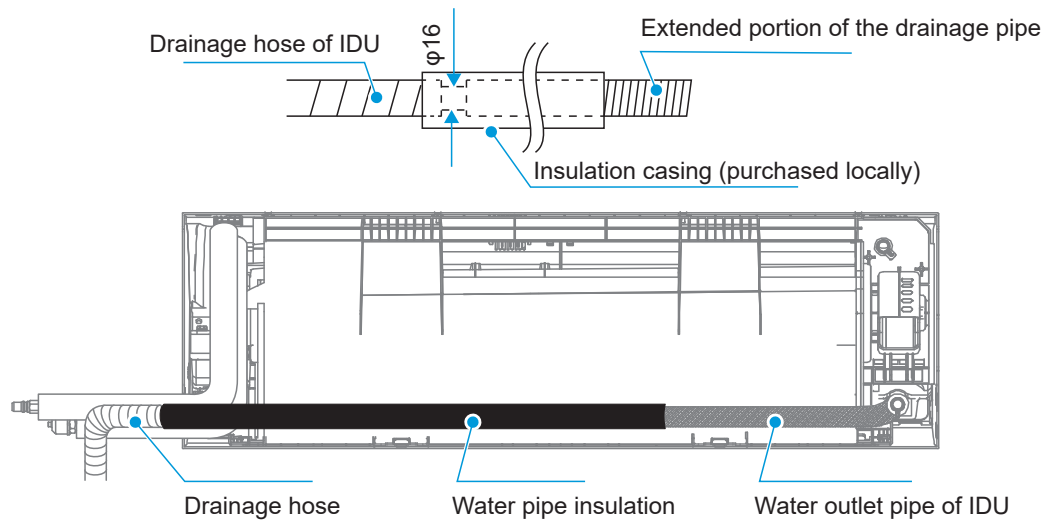

! Caution

Indoor parts of the drainage pipe shall be insulated to prevent condensation, and protective sleeves should be thicker than 10mm.

If the pipe is not wholly insulated, be sure to rebind the cut part.

Use glue or buckles to connect the joints and cuts of the thermal insulation pipe, and make sure it is at the top of the pipe.

After the drainage test shows that there are no leaks, carry out the insulation of the drainage pipe.

3 Lay and insulate pipes.

- ① Straighten and place the connecting pipes on the floor, and lay the drainage pipe and various cables (remember to distinguish the two ends of the cable) around the connecting pipes.
- ② Measure and adjust the distances of the low-pressure pipe, high-pressure pipe and various cables based on the mouth of the drainage pipe, and bind them together with cable ties.
- ③ Sort the pipes and cables in the following sequence: drainage pipe at the bottom, connecting pipe in the middle, and power cable at the top.
- ④ Start wrapping from the drainage pipe and tie a fast knot.

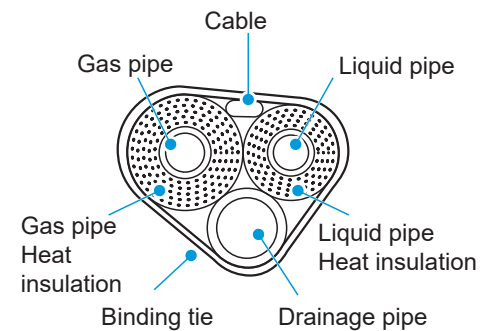

Note: If the drainage pipe is wrapped above the piping, it may cause poor drainage or backflow of water.

💡 Note

The number and type of cables may vary from model to model.

Both ends of the cable are different, so make sure the cable end is correct before binding the pipes.

The binding shall be seamless and neat in appearance.

4 Hang the IDU.

- ① Pass the properly bundled pipeline and connection lines through the wall hole, making sure that the pipe socket is not damaged, and that the connecting pipes of the unit are free of sand and dust.
- ② Hang the buckle at the back of the indoor unit on the upper hooker of the installation board. Shift the indoor unit left and right to check that the unit is securely and firmly mounted.
- ③ Push the lower part of the indoor unit against the wall, and shift the unit body up and down and left and right to check that the connection is secure.
- ④ Until the indoor unit can be connected properly, make sure that the indoor unit is buckled into the slots. Use your hands to shake the unit to check that it does not move up, down, left or right. Use a spirit level to verify that the indoor unit is level.

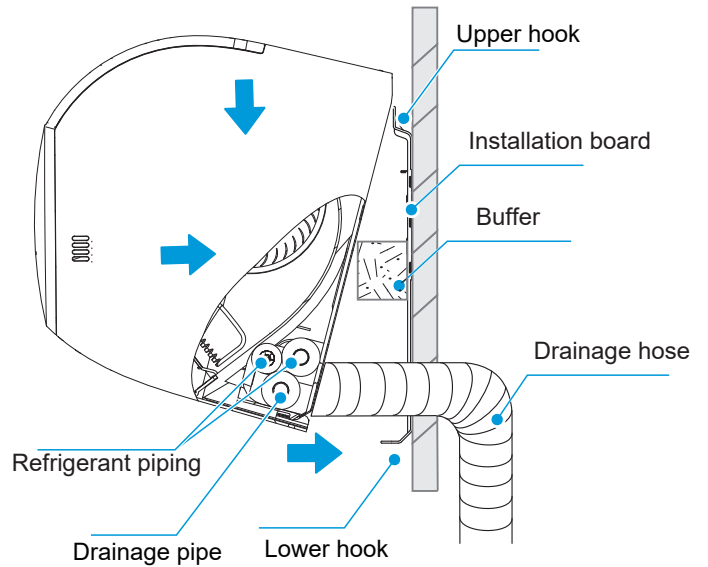

5 Install sealant and wall hole sleeve cover.

- ① Arrange the wrapped pipes.
- ② Apply the sealant to the gap between the pipe and wall and press it tightly.
- ③ Pull open the wall hole sleeve cover, and insert the pipe through the hole until it is pressed against the wall.

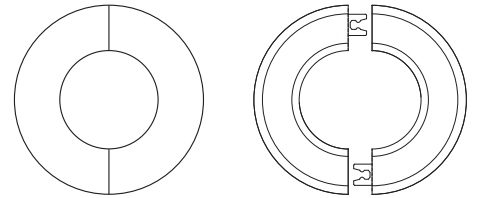

6 Perform drainage test.

Drainage

- ① Open the panel assembly and remove the filter.
- ② Fill the fins of the heat exchanger with water.
- ③ After confirming that the drainage is smooth and free of water leakage, install the filter and close the panel assembly.

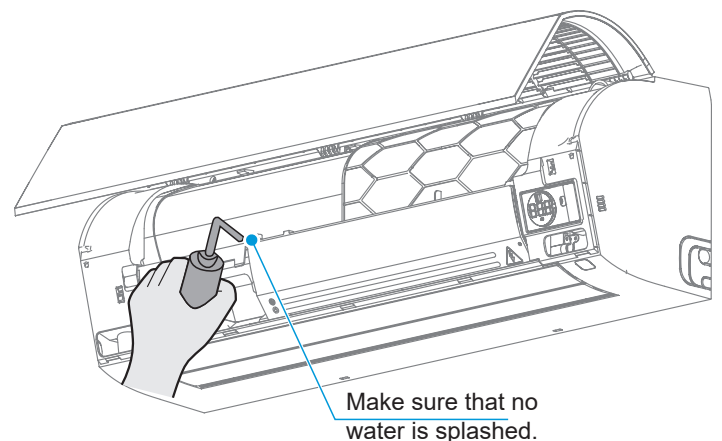
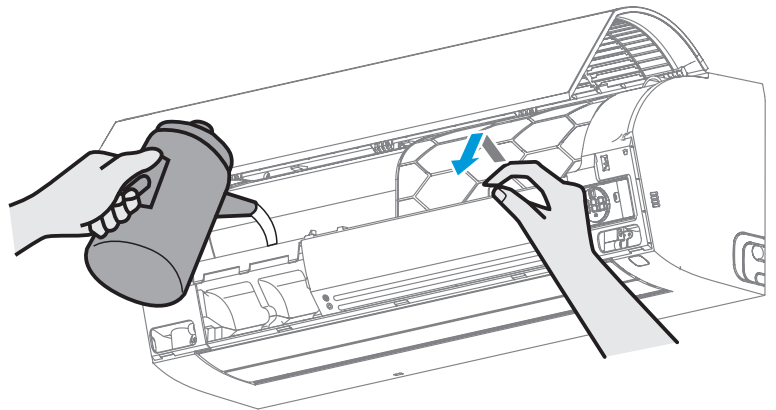

3 Electrical Connection

Danger

The power supply must be cut off before any electrical work is carried out. Do not conduct electrical work when the power is on; otherwise, it may cause serious personal injury.

The air conditioning unit must be grounded reliably and must meet the requirements of the local country/region. If the grounding is not reliable, serious personal injury due to electric leakage may occur.

Warning

Installation, inspection or maintenance operations must be completed by professional technicians. All parts and materials must comply with the relevant regulations of the local country/region.

The air conditioning unit must be equipped with a special power supply, and the power supply voltage should conform to the nominal working voltage range of the air conditioning unit.

The power supply of the air conditioning unit must be equipped with a power disconnect device that conforms to the requirements of relevant local technical standards for electrical equipment. The power disconnecting device must have the functions of short circuit protection, overload protection and electric leakage protection. The clearance between open contacts of the power disconnecting device shall be at least 3mm.

The core of the power cable must be made of copper, and the wire diameter should meet the current-carrying requirements. For details, refer to the "Power Cable Diameter and Electric Leakage Protector Selection". A wire diameter that is too small may cause the power cable to heat up, resulting in a fire.

The power cable and the ground wire should be secured reliably to avoid stress on the terminals. Do not pull the power cable forcibly; otherwise, the wiring may become loosened or the terminal blocks may be damaged.

Strong current wires such as power cables cannot be connected to weak current wires such as communication lines; otherwise, the product may become seriously damaged.

Do not bond and connect the power cable. Bonding and connecting the power cable may cause it to heat up, resulting in a fire.

Caution

Bonding and connecting the communication line should be avoided, but if it is used, at the very least, ensure a reliable connection by crimping or soldering and make sure the copper wire at the connection is not exposed; otherwise, communication failure may occur.

The power cable and communication line must be routed separately, with a distance of over 5 cm. Otherwise, communication failure may occur.

Keep the vicinity of the air conditioning unit as clean as possible to avoid small animals from nesting and biting the cables. If a small animal touches or bites the cables, short circuiting or electric leakage may occur.

Do not connect the ground wire to the gas pipe, water pipe, lightning rod ground wire or telephone ground wire.

Gas pipe: Risk of explosion and fire when gas leaks.

Water pipe: If rigid plastic pipes are used, there will be no grounding effect.

Lightning rod ground wire or telephone ground wire: In the event of lightning strikes, abnormal ground potential may rise.

After all wiring is completed, check carefully before turning on the power supply.

Electrical Characteristics

Unit power (kW)	Electric specifications of the IDU				Indoor Fan Motor	
	Frequency (Hz)	Voltage (V)	MCA (A)	MFA (A)	Rated Motor Output (W)	FLA (A)
1.5	50	220~240	0.28	15	20	0.22
2.2			0.29		20	0.23
2.8			0.36		20	0.29
3.6			0.39		20	0.31
4.5			0.41		20	0.33
5.6			0.51		20	0.33
7.1			0.65		50	0.55
8.0			0.98		50	0.78

Notes:

MCA: Min. Circuit Amps. (A), which is used to select the minimum circuit size to ensure safe operation over a long period of time.

MFA: Max. Fuse Amps. (A), which is used to select the circuit breaker.

FLA: Full Load Amps. (A), which is the full load current of the indoor fan motor (reliable operation at the fastest speed setting).

Schematic diagram of the main terminal blocks of main control board

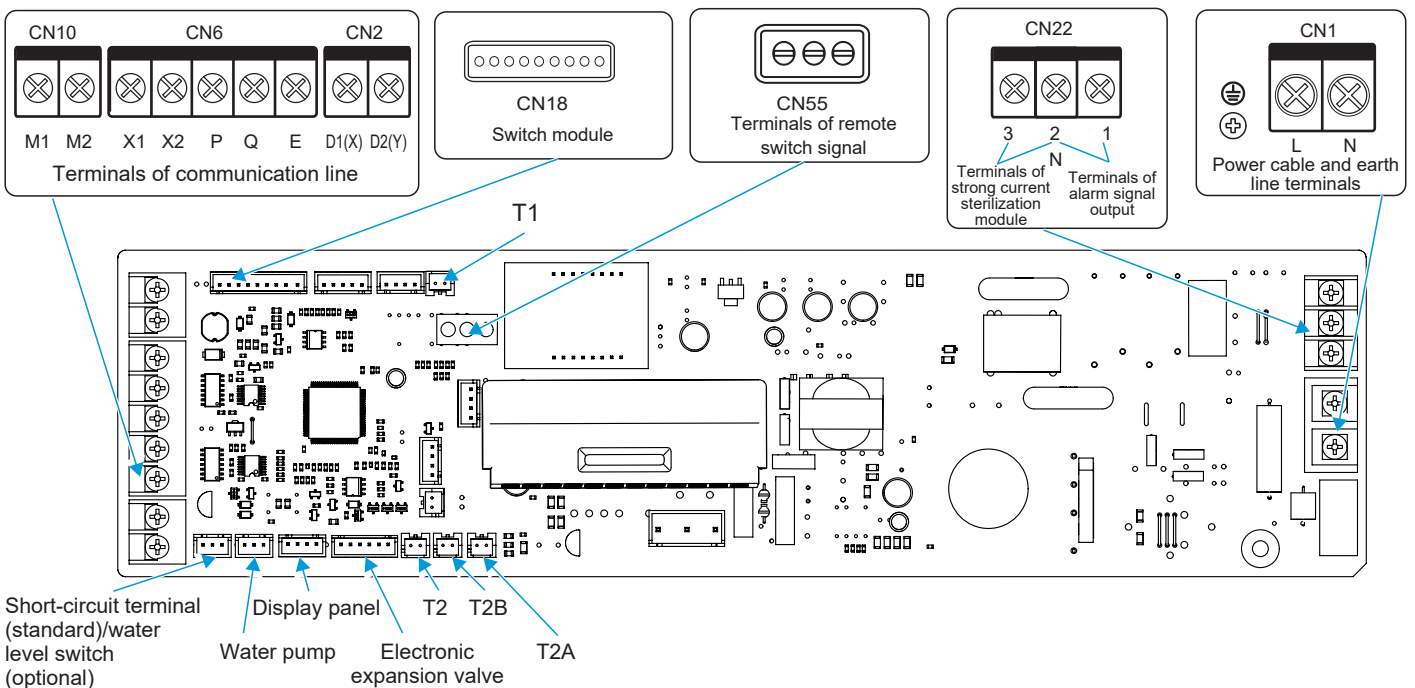

Caution



All weak point connection points meet SELV, such as X1, X2, P, Q, E, M1, M2, CN18, CN55 etc.

Wiring

- 1 Open the IDU's electric control box cover.
Loosen the screws on the right side of the electric control box cover and remove the electric control box cover.

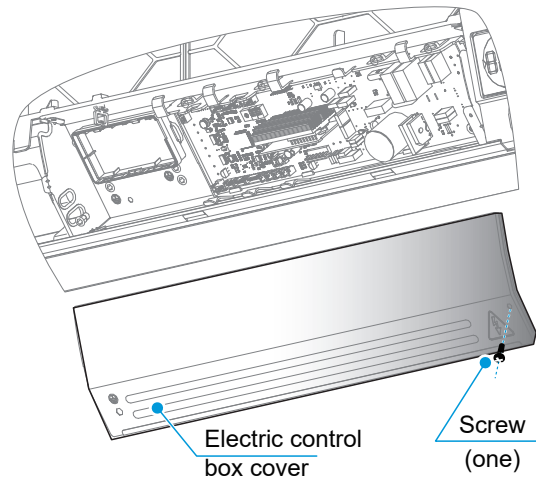

- 2 Connect the strong current wires (power cable, alarm signal output wire, and strong current sterilization wire) and weak current wires (communication line, expansion board connection wire, remote switch connection wire) to the electric control box through the bottom of the electric control box, and the strong and weak current inlets.

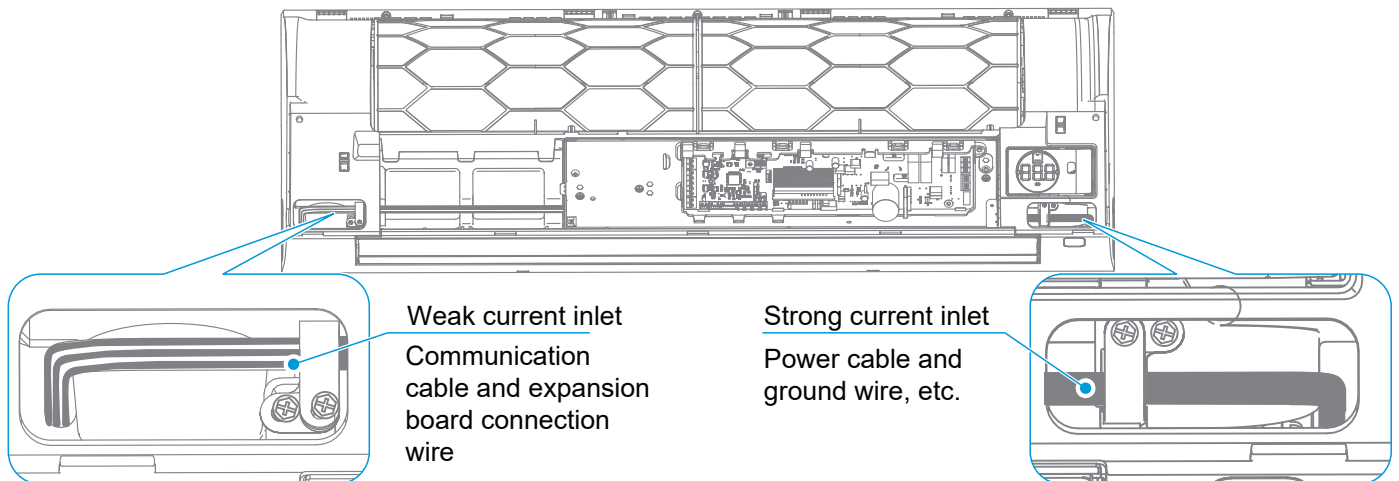

When there is a number of weak current wires, making it impossible for the cable clamp to fix all the wires, please use two ST3.6*6.5 self-tapping screws to fix the power cable clamp from the accessory package on the installation board, and fix those weak current wires that cannot be fixed on the drain pan here.

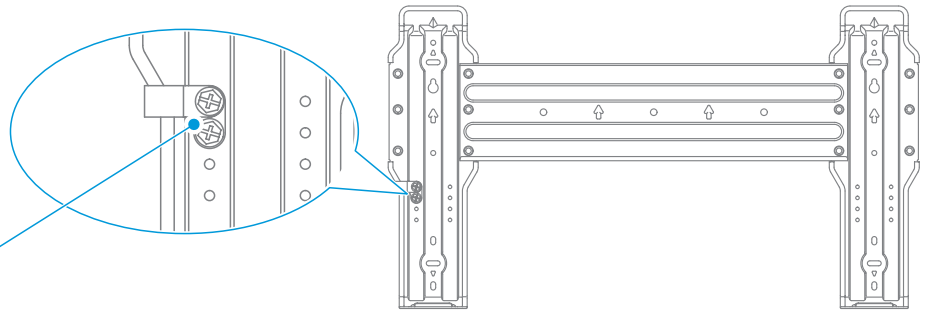

⚠ Caution

- The strong and weak current wires must be separated.
- The use of an adapter board and function expansion board are optional.
- Water level switch terminals are shorted when the water level switch is unavailable.

3 Power cable connection

1. Connection between the power cable and power supply terminal

The power supply terminal of the IDU is fixed on the main control board, the power cable is connected to the power supply terminal labeled "CN1" on the main control board. The live and neutral wires are connected according to the main control board logos "L" and "N", and the ground wire is directly connected to the electric control box sheet metal part.

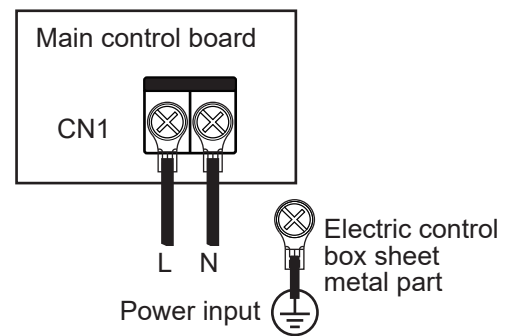

⚠ Caution

A Do not bond and connect the power cable. Bonding and connecting the power cable may cause it to heat up, resulting in a fire.

B The power cable must be crimped reliably using an insulated circular terminal block, and then connected to the power supply terminal of the IDU, as shown in the figure below.

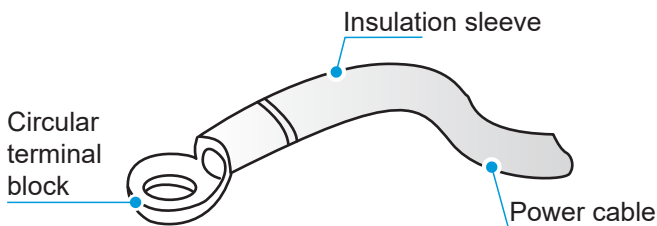

C If it fails to crimp the insulated circular terminal block due to on-site limitations, connect the power cables of the same diameter to both sides of the power supply terminal block of the IDU, as shown in the figure below.

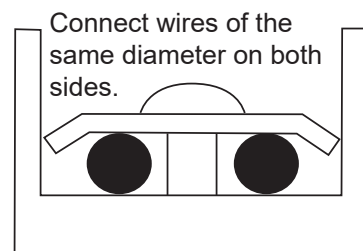

D Do not press the power cables of the same wire diameter on the same side of the terminal. Do not use two power cables of different wire diameters for the same terminal blocks; otherwise, they can easily loosen due to uneven pressure and cause accidents, as shown in the figure below.

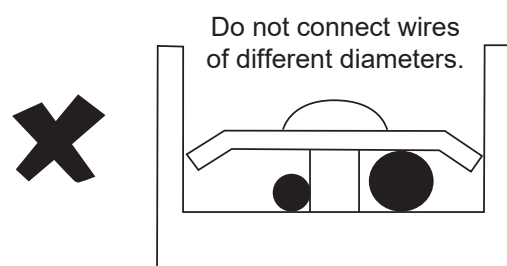
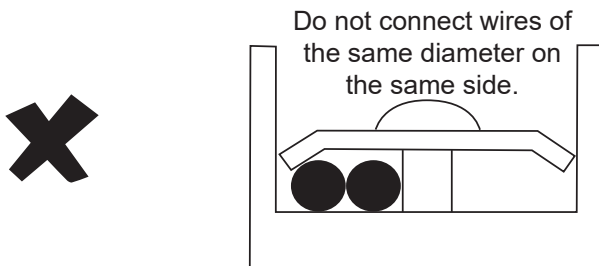

E The connected power cable should be secured with a wire clamp to prevent loosening, as shown in the figure.

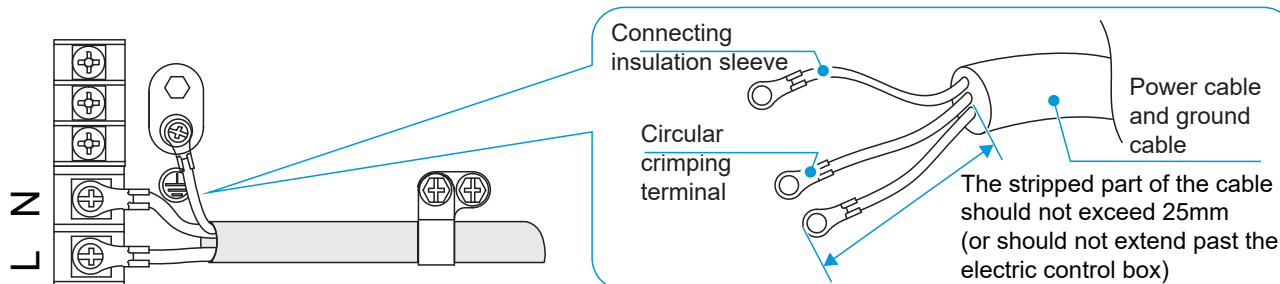

2. Power cable system connection

Power cable system connection depends on the forms of communication between the IDU and ODU. For the HyperLink communication form with independent power supply, IDUs are allowed to have independent power supply. For other communication forms, IDUs should be provided with uniform power supply.

A IDUs are provided with independent power supplies*, which are wired as follows:
For HyperLink communication with independent power supply:

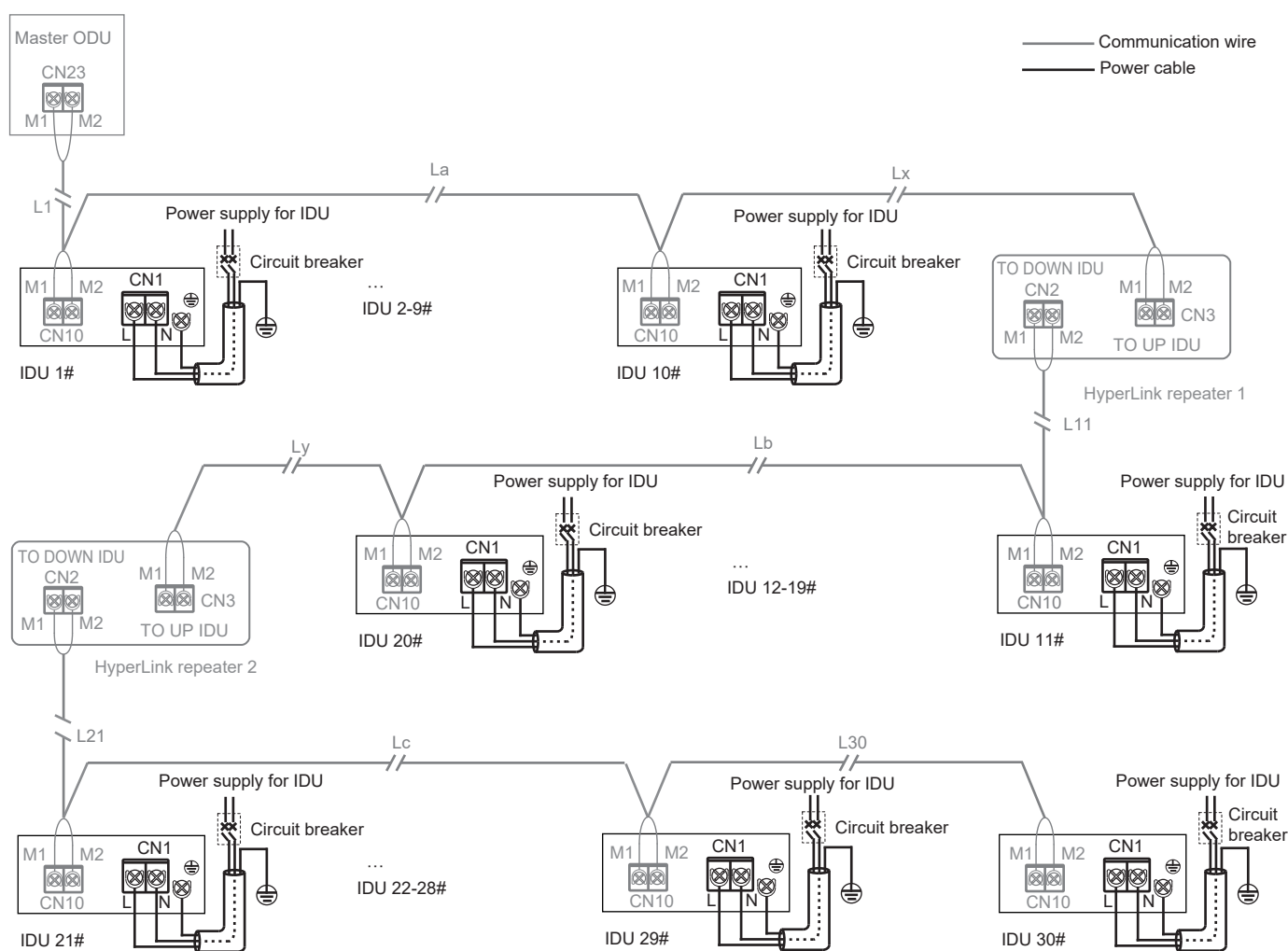

[Caution]

When the IDUs are provided with independent power supplies, the IDUs in the same refrigerant system should be V8 IDUs*, and the communication between IDUs and ODU adopts a HyperLink with an independent power supply.

This connection method has the function of an independent power supply, so in the same refrigerant system, the number of IDUs must not exceed 30 sets, and a maximum of only two repeaters may be installed*.

One repeater shall be added for every 10 IDUs or a communication distance of 200m added.

B IDUs are provided with uniform power supply*, which are wired as follows:

1. HyperLink communication with the uniform power supply:

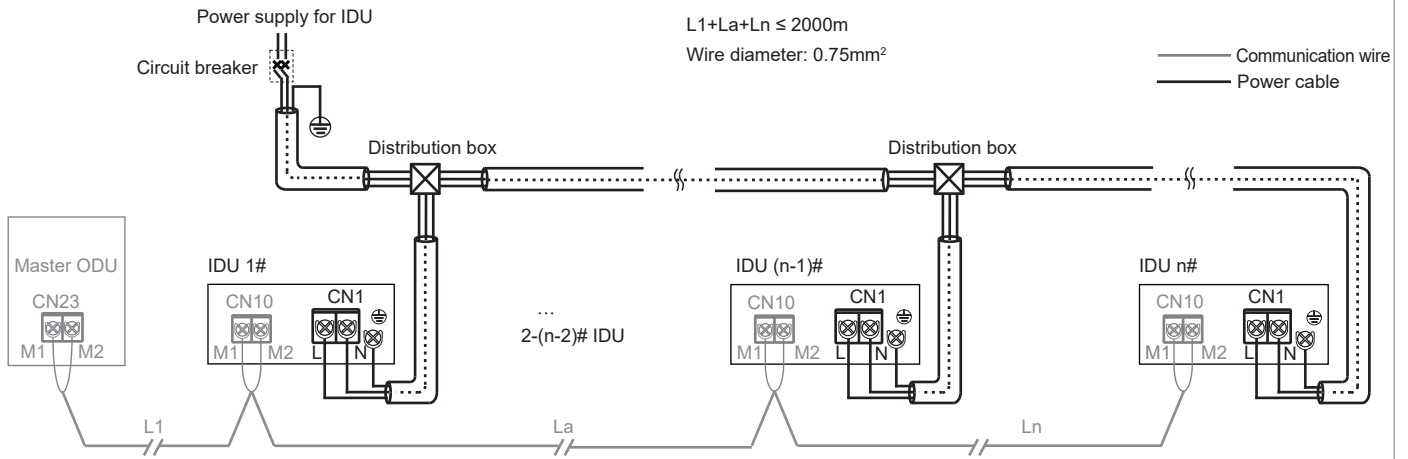

2. P/Q communication:

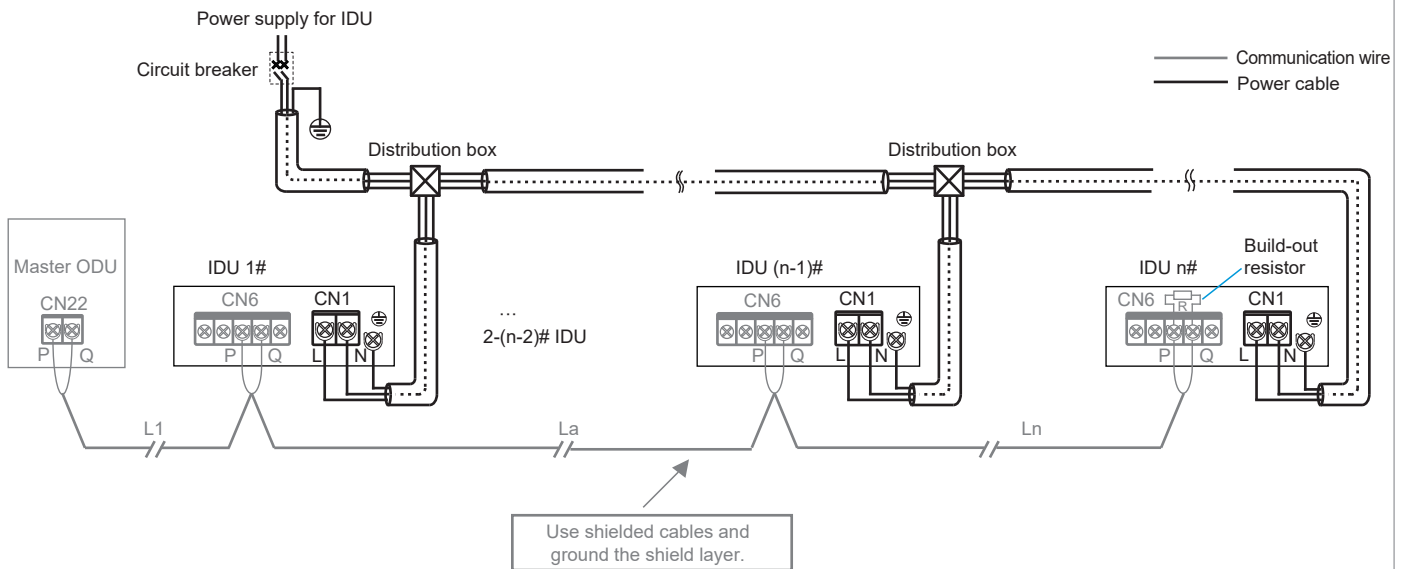

3. P/Q/E communication:

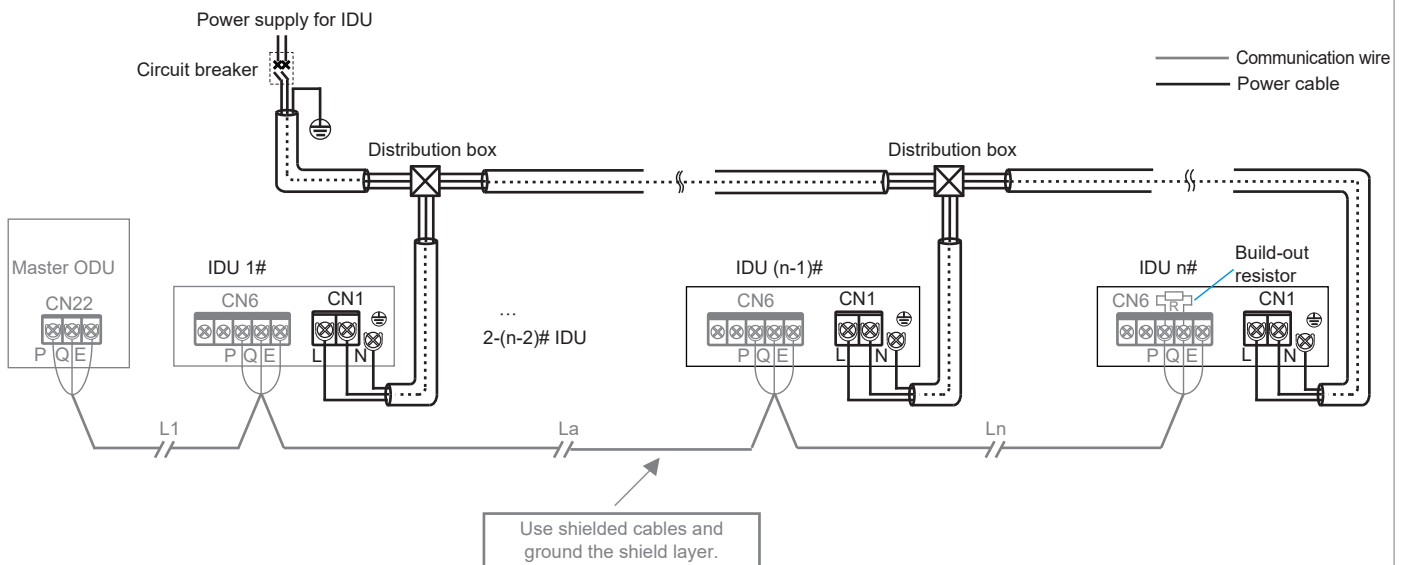

Caution

When the IDUs are provided with a uniform power supply, if the IDUs in the same refrigerant system are V8 IDUs, then IDUs and ODU can communicate either via HyperLink with a uniform power supply, or via P/Q. If some of the IDUs in the same refrigerant system are non-V8 series, then IDUs and ODU can only communicate via P/Q or P/Q/E communication.

Both P/Q communication and HyperLink communication (M1M2) are indoor and outdoor communication, and only one of them can be selected. Do not connect P/Q communication and HyperLink communication at the same time in the same system. Do not connect HyperLink communication to P/Q or D1D2 communication.

Note

V8 IDUs: with V8 printed on the packaging carton

Independent power supply: With separate circuit breakers, the power supply for each IDU can be controlled independently.

Uniform power supply: All the IDUs in the system are controlled by one circuit breaker.

Repeater: power supply repeater, which is used to compensate for the pressure drop due to excessive length of line or line resistance when the main control board of the ODU provides an independent power supply for IDUs through the HyperLink communication line. It is only used in refrigerant systems where IDUs are provided with an independent power supply.

4 Communication line connection

1. Selection of communication method for IDUs

Equipped with independently developed HyperLink (M1M2) communication, V8 series IDUs also preserve the previous RS-485 (PQE) communication method. They are compatible with non-V8 IDUs. Pay attention to the type of IDU you have purchased before connecting communication lines. Please refer to the following table to select an appropriate communication method.

IDU type	Optional communication method between IDUs and ODU	Remarks
Are all the IDUs in the system V8 series	HyperLink (M1M2) communication	<ol style="list-style-type: none">1. Independent power supply for IDUs*.2. Any topology connection of communication lines.3. Two-core and non-polar communication for M1M2.
	RS-485 (PQ) communication	<ol style="list-style-type: none">1. The IDUs need to be powered uniformly.2. The communication cables must be connected in serial.3. Two-core and non-polar communication for PQ.
Are some of the IDUs in the system non-V8 series	RS-485 (PQE) communication	<ol style="list-style-type: none">1. The IDUs need to be powered uniformly.2. The communication cables must be connected in serial.3. PQE cables must be 3-core and PQ non-polar.

2. Table of selection of communication line diameter

Function	IDU and ODU communication				One controller to one IDU (two controllers to one IDU) communication	One-to-more (centralized control) communication
	HyperLink communication (IDUs are powered independently)	HyperLink communication (IDUs are powered uniformly)	P/Q communication (IDUs are powered uniformly)	P/Q/E communication (IDUs are powered uniformly)	X1X2 communication	D1D2 communication
Wire diameter	2 × 1.5mm ² Wire resistance ≤ 1.33Ω/100m	2 × 0.75mm ²	2 × 0.75mm ² (shielded cable)	3 × 0.75mm ² (shielded cable)	2 × 0.75mm ² (shielded cable)	2 × 0.75mm ² (shielded cable)
Length	≤ 600m (add two repeaters)	≤ 2000m	≤ 1200m	≤ 1200m	≤ 200m	≤ 1200m

Caution

Please select the communication line according to the requirements in the above reference table. Use shielded cables for communication when strong magnetism or interference is present.

On-site wiring must comply with the relevant regulations of the local country/region and must be completed by professionals.

Do not connect the communication line when the power is on.

Do not connect the power cable to the communication terminal; otherwise, the main control board may be damaged.

The standard value of the screw torque of the communication line terminal is 0.5N·m. Insufficient torque may cause poor contact; excessive torque may damage the screws and power supply terminals.

Both HyperLink communication and PQ communication are internal and external, so only one of the two can be selected. Do not connect both HyperLink communication line and PQ communication line to the same system, otherwise the IDU and ODU cannot communicate normally.

If some of the IDUs in the same refrigerant system are non-V8 series, only P/Q/E communication can be selected for the IDU and ODU communication. The three-core shielded cable of 3×0.75mm² is required to connect "P", "Q", and "E".

Do not bundle the communication line with the refrigerant pipeline, power cable, etc. When the power cable and the communication line are laid in parallel, a distance of more than 5cm should be maintained to prevent interference from the signal source.

When the construction personnel of the IDU and ODU are working separately, information communication and synchronization are required. Do not connect the ODU to HyperLink and the IDU to PQ. Do not connect the ODU to PQ and the IDU to HyperLink.

Bonding and connecting the communication line should be avoided, but if it is used, at the very least, ensure a reliable connection by crimping or soldering and make sure the copper wire at the connection is not exposed; otherwise, communication failure may occur.

3. IDU and ODU communication

A HyperLink communication (with independent power supply)

Single unit: HyperLink communication is a new type of IDU and ODU communication technology. When the IDUs are provided with independent power supplies, use $2 \times 1.5\text{mm}^2$ communication cables. M1 and M2 ports are located at terminal block "CN10" of the main control board. There is no distinction between negative and positive electrodes. For details, see the following figure:

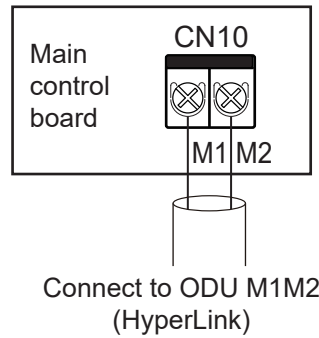

⚠ Caution

Do not connect the HyperLink communication line to the PQ or D1D2 communication line.

System: The HyperLink communication line with an independent power supply between IDU and ODU can reach a length of up to 600 meters, supporting any topology connection. The following figure shows a serial connection:

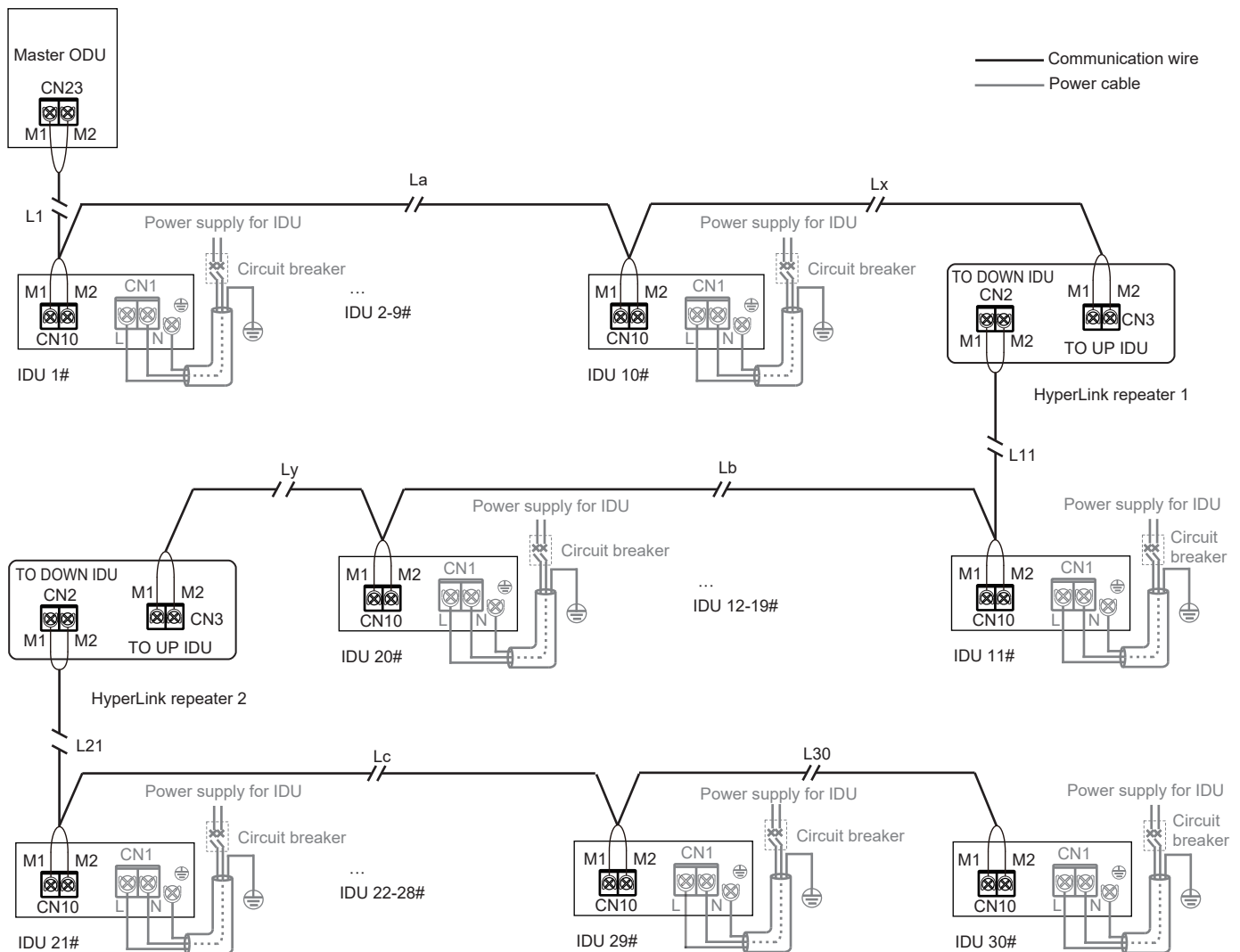

$$L1+L_a+L_x \leq 200\text{m} \quad L_{11}+L_b+L_y \leq 200\text{m} \quad L_{21}+L_c+L_{30} \leq 200\text{m}$$

For other connection methods (tree topology, star topology, ring topology), please refer to the technical manual or consult technical personnel.

Caution

If the total distance is $\leq 200\text{m}$ and the total number of IDUs is ≤ 10 sets, the valve is powered and controlled by the master ODU.

If the total distance is longer than 200m or the total number of IDUs is more than 10 sets, a repeater is required to increase the bus voltage.

The load capacity of the repeater is the same as that of the ODU, and it can load a bus length of 200m or 10 IDUs.

The number of IDUs requiring power supply in the same refrigerant system does not exceed 30 sets.

A maximum of two repeaters can be installed in the same refrigerant system.

Keep the power on/off for both the repeater and the ODU, or use an uninterruptible power supply.

For repeater installation, refer to the repeater installation manual. Do not connect the upstream and downstream IDU ports of the repeater in reverse; otherwise, it will cause a communication failure.

The repeater is optional. If you need to purchase it, please contact your local dealer.

B HyperLink communication (with uniform power supply)

Single unit: When the IDUs are provided with uniform power supply, it is not necessary for HyperLink communication line to provide independent power supply for IDUs. In this case, use $2 \times 0.75\text{mm}^2$ communication cables. M1 and M2 ports are located at terminal block "CN10" of the main control board. There is no distinction between negative and positive electrodes. For details, see the following figure:

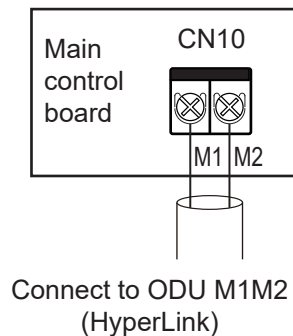

Caution

Do not connect the HyperLink communication line to the PQ or D1D2 communication line.

System: The HyperLink communication line with a uniform power supply between IDU and ODU can reach a length of up to 2000 meters, supporting any topology connection. The following figure shows a serial connection:

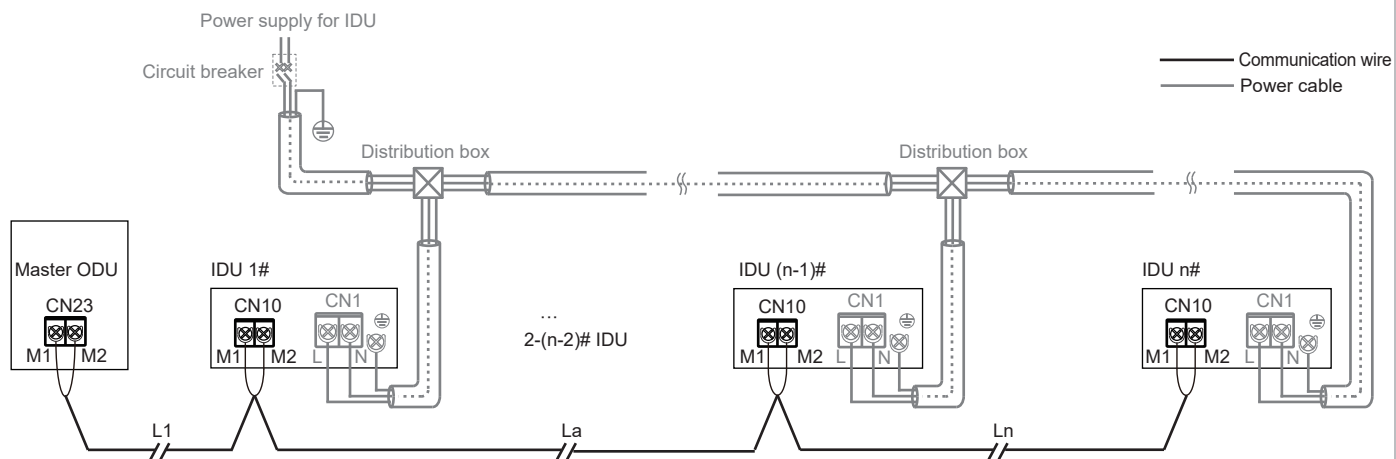

$$L1 + La + Ln \leq 2000m$$

For other connection methods (tree topology, star topology, ring topology), please refer to the technical manual or consult technical personnel.

Caution

- When HyperLink with a uniform power supply is available, a uniform power supply for IDUs is required. For details, see "Power Cable Connection".
- When HyperLink with a uniform power supply is available, there is no need to connect a repeater to the system.

C P/Q communication

Single unit: Use a shielded cable for the P/Q communication and properly ground the shield layer. P and Q ports are located at terminal block "CN6" of the main control board. There is no distinction between negative and positive electrodes. Connect the shield layer to the sheet metal of the electric control box, as shown in the following figure:

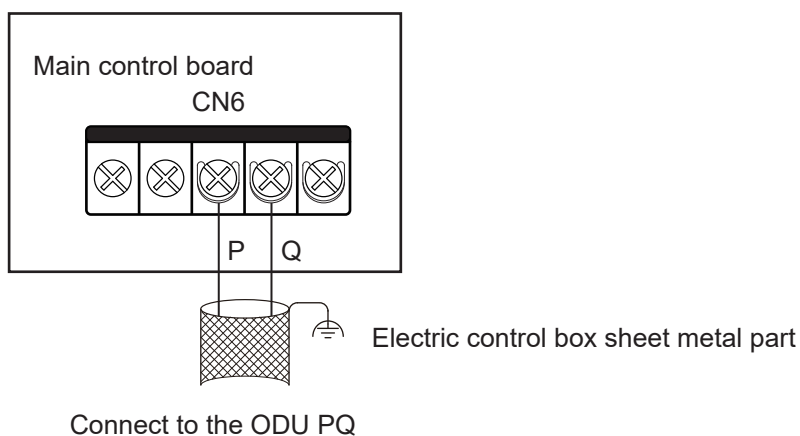

System: The maximum total length of the P/Q communication cable of the IDU and ODU can be up to 1200m, and can be connected in serial, as shown in the figure below:

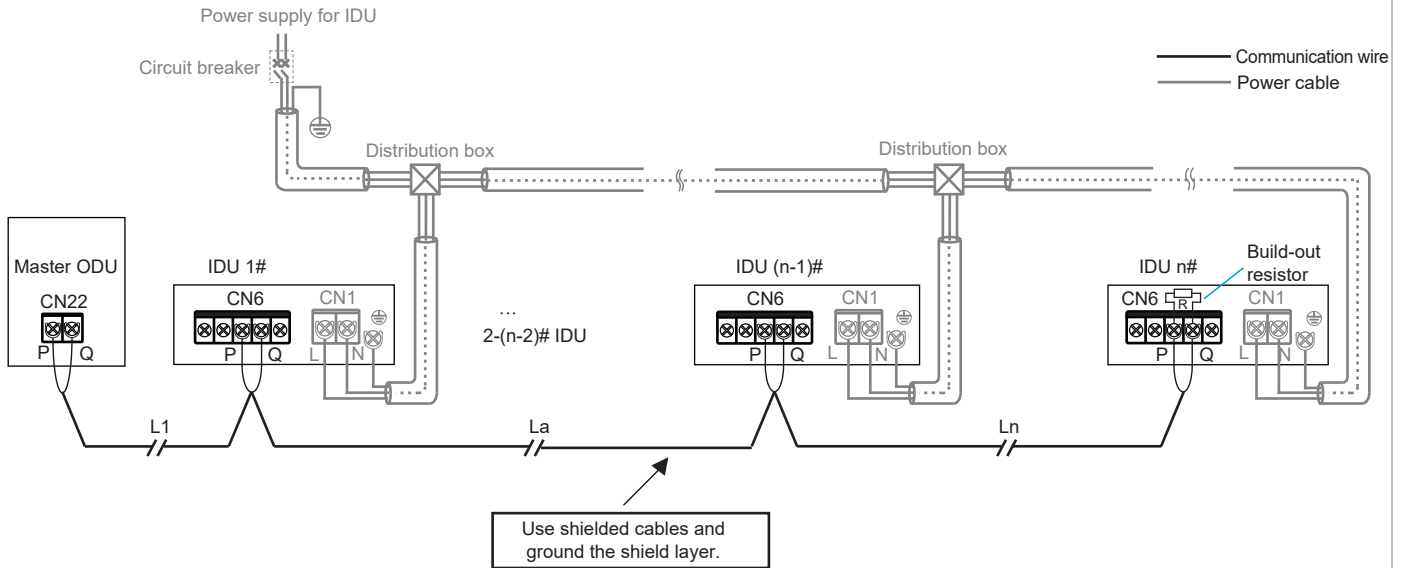

$$L1 + La + Ln \leq 1200m$$

D P/Q/E communication

If some of the IDUs in the same refrigerant system are non-V8 series, it is required to connect "P", "Q", and "E" for P/Q/E communication.

Single unit: Use a shielded cable for the P/Q/E communication and properly ground the shield layer. P, Q, and E ports are located at terminal block "CN6" of the main control board. There is no distinction between negative and positive electrodes. Connect the shield layer to the sheet metal of the electric control box, as shown in the following figure:

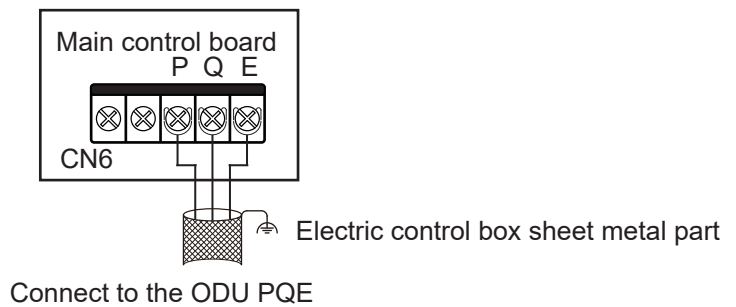

System: The maximum total length of the P/Q/E communication cable of the IDU and ODU can be up to 1200m, and can be connected in serial, as shown in the figure below:

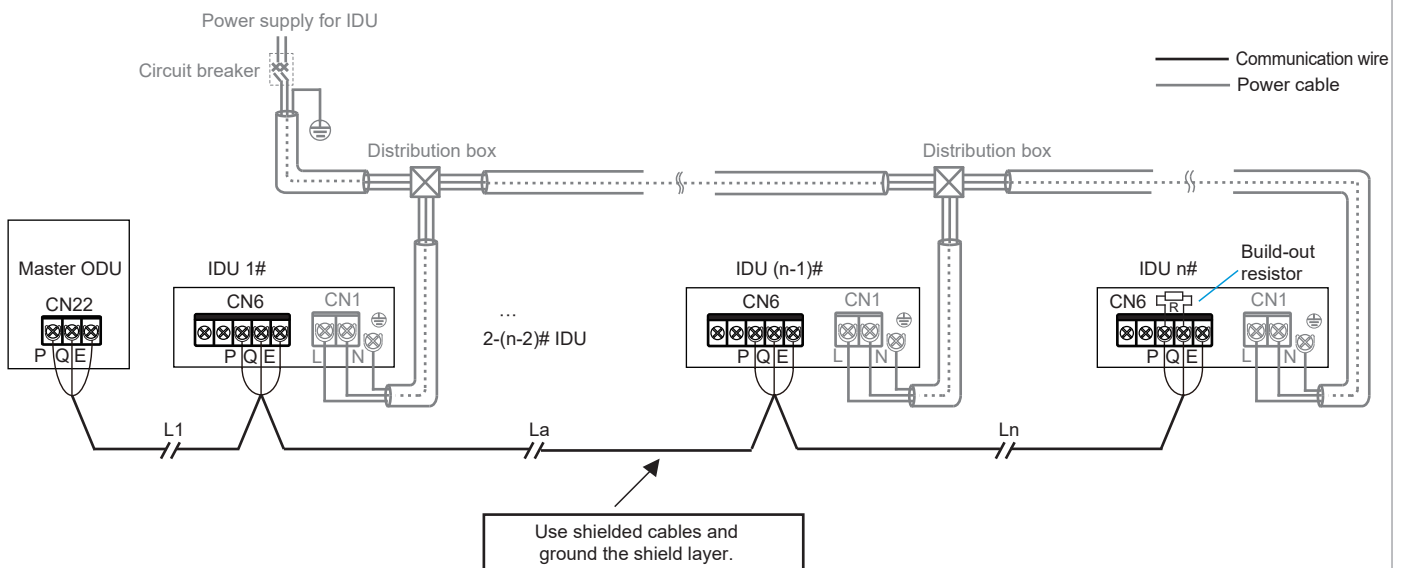

$$L1 + La + Ln \leq 1200m$$

Caution

When P/Q or P/Q/E communication is used, the IDUs need to be powered uniformly.

Either P/Q, P/Q/E communication or HyperLink communication can be selected. If it is required for IDUs to have independent power supplies, then HyperLink communication must be selected.

Use only shielded cables for P/Q or P/Q/E communication. Otherwise, the IDU and ODU communication may be affected.

A matching resistor needs to be added to the last IDU on the PQ (in the accessory bag of the ODU).

4. X1/X2 communication cable connection

The X1X2 communication line is mainly connected to the wired controller to achieve one controller per IDU and two controllers per IDU. The total length of the X1X2 communication line can reach 200 meters. Please use shielded wires, but the shield layer cannot be grounded. X1 and X2 ports are located at terminal block "CN6" of the main control board. There is no distinction between negative and positive electrodes. For details, see the following figure:

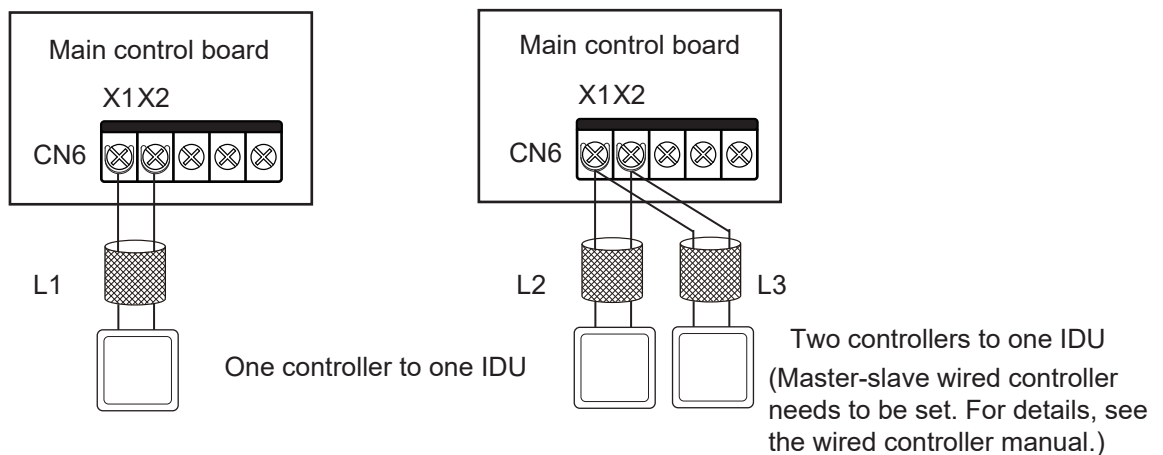

$L1 \leq 200\text{m}$, $L2+L3 \leq 200\text{m}$.

Caution

Two wired controllers of the same model can be used to control one IDU at the same time. In this case, you need to set one controller to be the master and the other to be the slave. For details, see the wired controller manual.

5. D1D2 communication line connection (limited to ODU and system configuration)

A Achieving one-to-multiple and two-to-multiple functions of the IDU wired controller through D1D2 communication (a maximum of 16 sets)

D1D2 communication is 485 communication. The one-to-more and two-to-more functions of the IDU wired controller can be achieved through D1D2 communication, as shown in the figure below:

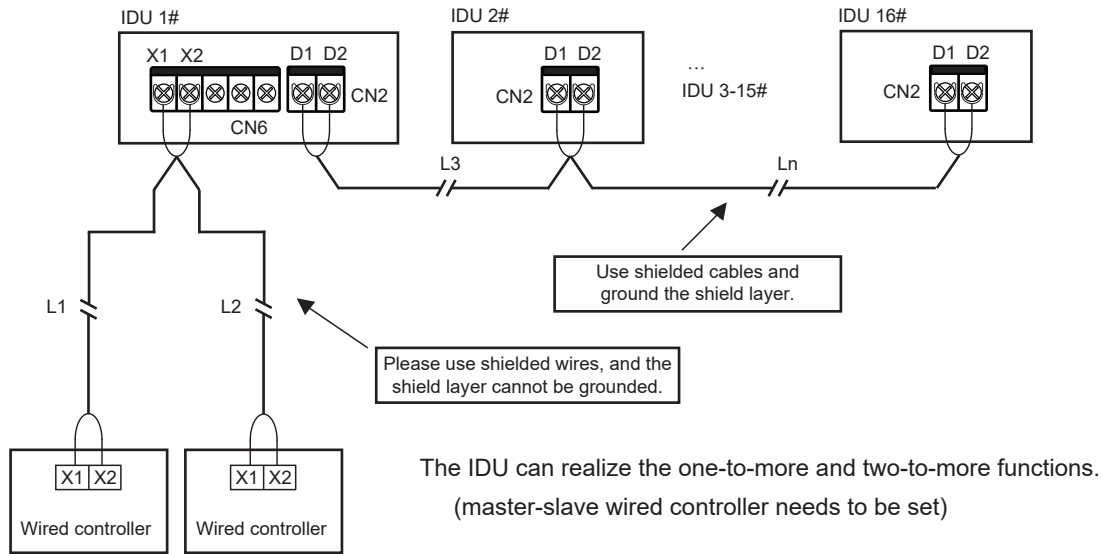

$$L1+L2 \leq 200\text{m}, L3+L_n \leq 1200\text{m}$$

⚠ Caution

When the IDUs in the same refrigerant system are V8 IDUs, D1D2 communication can enable one-to-multiple and two-to-multiple functions of the IDU wired controller.

To enable two-to-multiple functions, wired controllers must be of the same model.

B Achieving centralized control of the IDU through D1D2 communication

The D1D2 communication line can also be connected to the centralized controller to achieve centralized control of the IDU, as shown in the figure below:

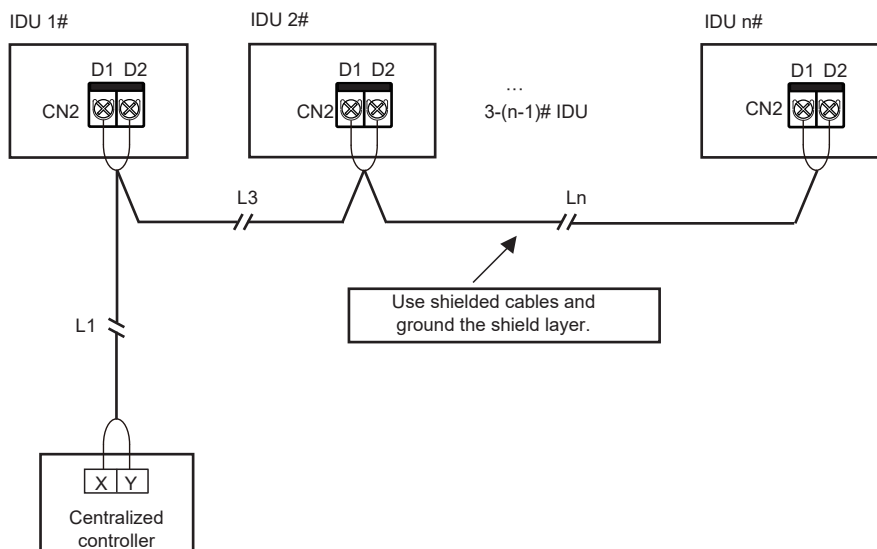

$$L1+L3+L_n \leq 1200\text{m}$$

5 External board connection (limited to ODU and system configuration)

The external board is a connection module outside the main control board, including a Switch module, and 1# Expansion board and 2# Expansion board.

1. Display panel connection

The display panel is connected to the main control board through a 4-core cable, and is connected to the "CN30" socket of the main control board, as shown in the following figure:

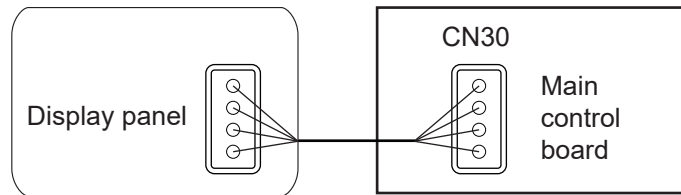

1. Switch module connection

Expansion boards can communicate with the main control board through the adapter board. You can use one or both of the two expansion boards. The wiring diagrams are as follows:

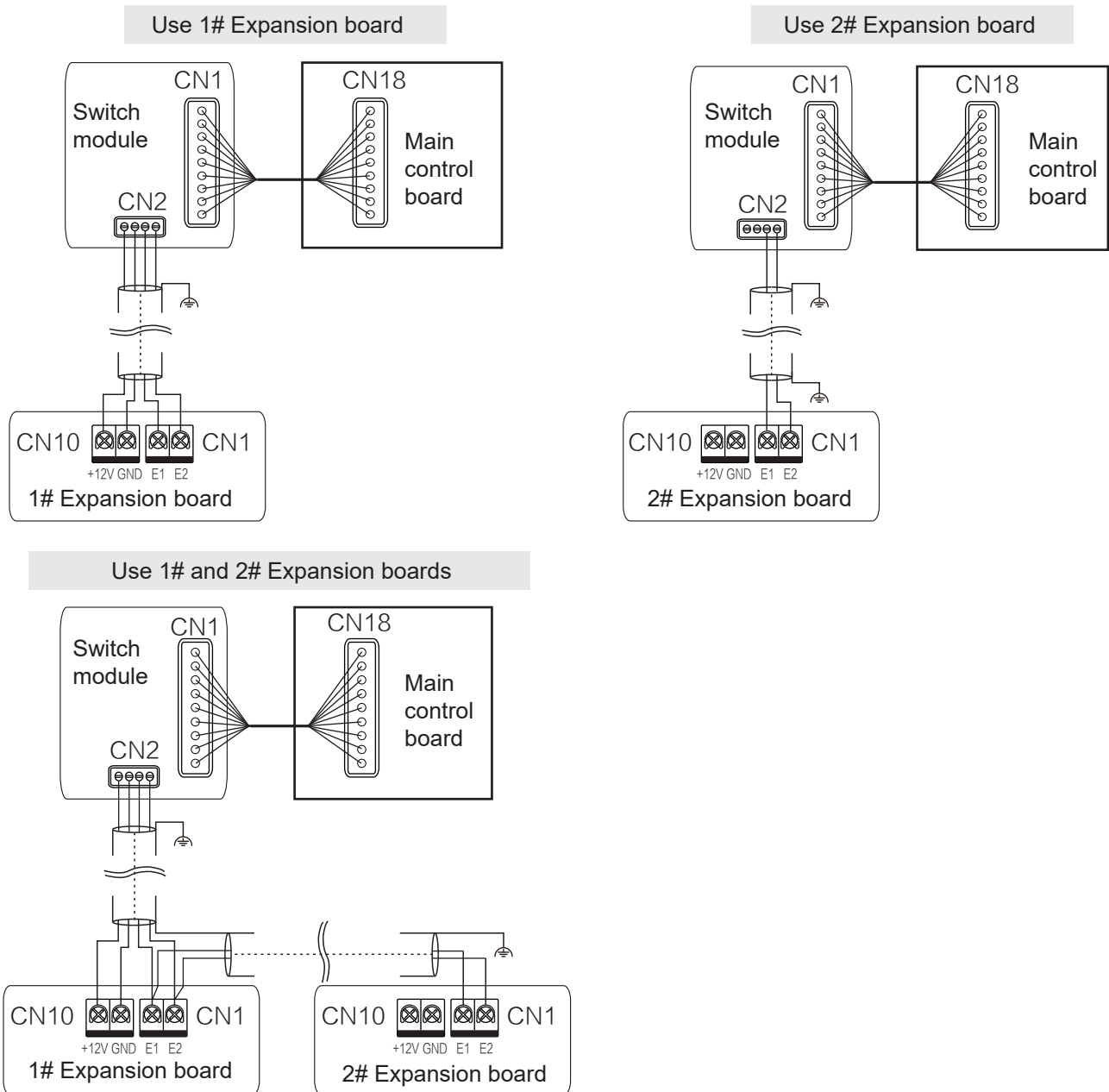

⚠ Caution

For the function introduction of the Switch module, function expansion board 1#, and function expansion board 2#, please refer to the function module manual.

6 Reclose the electric control box cover

Straighten out the connecting wires and lay them flat, and separate and fix the strong- and weak-current cables with cable clamps.

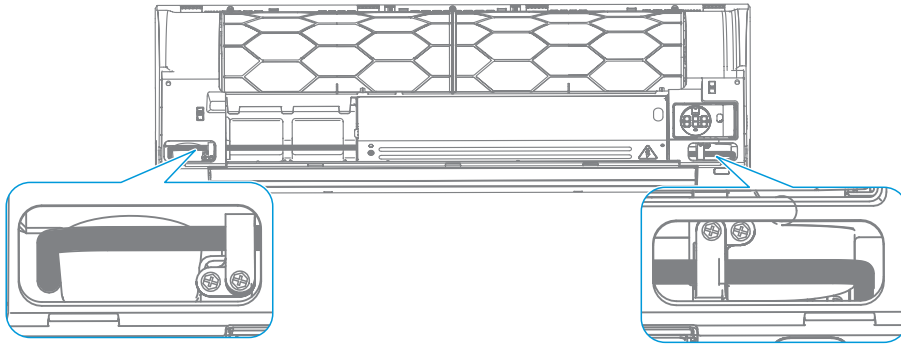

Caution

Do not cover the electric control box during power-on.

When covering the electric control box, arrange the cables carefully and do not clip the connecting wires on the electric control box cover.

4 Application Control









Error Codes and Definitions

In the following circumstances (warning failures excluded), please stop the air conditioner immediately, cut off the power switch and contact the local air conditioner customer service center. The error code is displayed on the display panel and the wired controller display.









Error	Error code	Digital display
Emergency stop	A01	
R32 refrigerant leaks, requiring shutdown immediately	A11	
ODU fault	A51	
The fault of the linked FAPU is transmitted to the master IDU (series setting)	A71	
The fault of the linked humidifying IDU is transmitted to the master IDU	A72	
The fault of the linked FAPU is transmitted to the master IDU (non-series setting)	A73	
The fault of the AHU Kit slave unit is sent to the master unit	A74	
Self-check fault	A81	
MS (refrigerant flow direction switching device) fault	A82	
Mode conflict (V6 communication protocol adopted)	A91	
1# EEV coil fault	b11	
1# EEV body fault	b12	
2# EEV coil fault	b13	
2# EEV body fault	b14	
Stall protection on 1# water pump	b34	
Stall protection on 2# water pump	b35	
Water level switch alarm	b36	
Reheating electric heater fault	b71	
Preprocessing electric heater fault	b72	
Humidifier fault	b81	
Duplicate IDU address code	C11	

Error	Error code	Digital display
Abnormal communication between the IDU and ODU	C21	
Abnormal communication between the IDU main control board and fan drive board	C41	
Abnormal communication between the IDU and wired controller	C51	
Abnormal communication between the IDU and Wi-Fi Kit	C52	
Abnormal communication between the IDU main control board and display board	C61	
Abnormal communication between the AHU Kit slave unit and master unit	C71	
Number of AHU Kits is not the same as the set number	C72	
Abnormal communication between the linked humidifying IDU and master IDU	C73	
Abnormal communication between the linked FAPU and master IDU (series setting)	C74	
Abnormal communication between the linked FAPU and master IDU (non-series setting)	C75	
Abnormal communication between the main wired controller and secondary wired controller	C76	
Abnormal communication between the IDU main control board and 1# function expansion board	C77	
Abnormal communication between the IDU main control board and 2# function expansion board	C78	
Abnormal communication between the IDU main control board and adapter board	C79	
Air inlet temperature of the IDU is too low in heating mode	d16	
Air inlet temperature of the IDU is too high in cooling mode	d17	
Alarm for exceeding temperature and humidity range	d81	
Sensor control board fault	dE1	
PM2.5 sensor fault	dE2	
CO2 sensor fault	dE3	
Formaldehyde sensor fault	dE4	
INTELLECTUAL EYE sensor fault	dE5	
T0 (fresh inlet air temperature sensor) short-circuits or cuts off	E21	
The upper dry bulb temperature sensor short-circuits or cuts off	E22	
The lower dry bulb temperature sensor short-circuits or cuts off	E23	
T1 (IDU return air temperature sensor) short-circuits or cuts off	E24	

Error	Error code	Digital display
The built-in room temperature sensor of the wired controller short-circuits or cuts off	E31	
The wireless temperature sensor short-circuits or cuts off	E32	
The external room temperature sensor short-circuits or cuts off	E33	
Tcp (pre-cooled fresh air temperature sensor) short-circuits or cuts off	E61	
Tph (pre-heated fresh air temperature sensor) short-circuits or cuts off	E62	
TA (outlet air temperature sensor) short-circuits or cuts off	E81	
Outlet air humidity sensor fault	EA1	
Return air humidity sensor fault	EA2	
Upper wet bulb sensor fault	EA3	
Lower wet bulb sensor fault	EA4	
R32 refrigerant leakage sensor fault	EC1	
T2A (heat exchanger inlet temperature sensor) short-circuits or cuts off	F01	
T2 (heat exchanger middle temperature sensor) short-circuits or cuts off	F11	
T2 (heat exchanger middle temperature sensor) overtemperature protection	F12	
T2B (heat exchanger outlet temperature sensor) short-circuits or cuts off	F21	
Main control board EEPROM fault	P71	
IDU display control board EEPROM fault	P72	
Locked (electronic lock)	U01	
Unit model code not set	U11	
Horsepower code not set	U12	
Horsepower code setting error	U14	
AHU Kit fan control input signal DIP setting error	U15	
Address code not detected	U38	
Motor failed more than once	J01	
IPM (fan module) overcurrent protection	J1E	
Instantaneous overcurrent protection for phase current	J11	

Error	Error code	Digital display
Low bus voltage fault	J3E	
High bus voltage fault	J31	
Phase current sample bias error	J43	
Motor and IDU are unmatched	J45	
IPM and IDU are unmatched	J47	
Motor startup failure	J5E	
Motor blocking protection	J52	
Speed control mode setting error	J55	
Phase lack protection of motor	J6E	

Operating Status Codes and Definitions (Non-Error)

Definition	Code	Digital display
Oil return or preheating operation	d0	
Self-cleaning	dC	
Mode conflict (V8 communication protocol adopted)	dd	
Defrosting	dF	
Static pressure detection	d51	
Remote shutdown	d61	
IDU backup operation	d71	
ODU backup operation	d72	
Main control program upgrading	OTA	

Caution

Error codes are displayed only for certain ODU models and IDU configurations (including the wired controller and display panel).

When the main control program is being upgraded, make sure that the IDU and ODU remain powered on. Otherwise, the upgrading process will stop.

Spot Check Description

Use the bi-directional communication wired controller (for example, WDC3-86S) to activate the spot check function in the following steps:

1. On the main page, hold "≡" and "▲" for 2s to enter the query page. The ODU displays u00-u03, the IDU displays n00-n63 (the last two digits show the IDU address), and the wired controller displays CC. Press the "▲" or "▼" key to select the IDU, and press the "↵" key to enter the parameter query page.
2. Press the "▲" or "▼" key to query the parameters, and the parameters can be queried cyclically. See the spot check list below for details.
3. Press the "⌚" key to exit the query function.
4. On the top of the query page, the "Timing area" displays the spot check serial number, and the "Temperature area" displays the content of the spot check parameters.

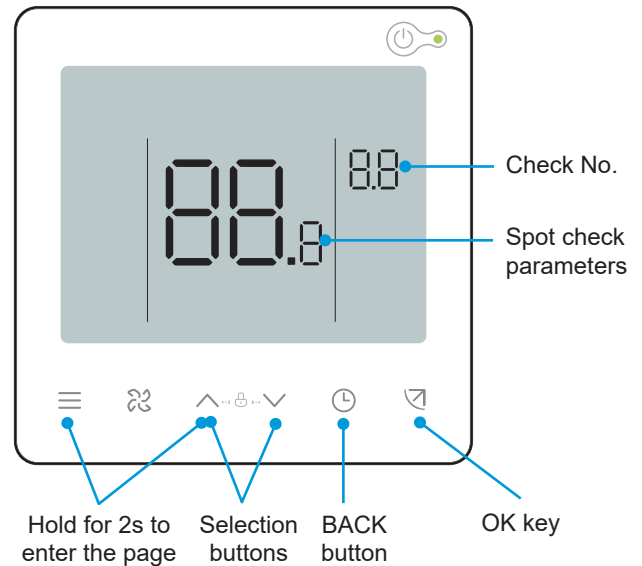

No.	Displayed content	No.	Displayed content
1	IDU and ODU communication address (current IDU addresses are displayed every 0.5s)	13	Compressor discharge temperature
2	Capacity HP of IDU	14	Target overheating
3	Actual set temperature Ts	15	EEV opening (actual opening/8)
4	Current running set temperature Ts	16	Software version No.
5	Actual T1 indoor temperature	17	Display board version No.
6	Modified indoor temperature T1_modify	18	Fan drive version No.
7	T2 heat exchanger intermediate temperature	19	Historical error code (recent)
8	T2A heat exchanger liquid pipe temperature	20	Historical error code (sub-recent)
9	T2B heat exchanger gas pipe temperature	21	IDU network address display
10	Actual set humidity RHs	22	IDU expansion board address display
11	Actual RH indoor humidity	23	[— — —] is displayed
12	Real-time static pressure		

5 Test Run

Before the Test Run, Make Sure That

- IDUs and the ODU are properly installed.
- The piping is correct, and the refrigerant piping system has been checked for leakage.
- Piping length and the amount of refrigerant charged have been recorded.
- The wiring is correct and firm without virtual connection issues. Ground wires have been properly connected.
- The voltage of the power supply is the same as the rated voltage of the air conditioner.
- Heat insulation is complete.
- There are no obstructions at the air inlet and outlet of the IDU and ODU.
- Fully open the check valves of the gas pipe and liquid pipe of the ODU.
- Turn on the power supply to preheat the ODU for 12 hours.

Test Run

Use the wired/remote controller to control the cooling or heating operation of the air conditioner according to the instructions.

In the event of a failure, please troubleshoot according to the "Symptoms That Are Not Faults" in the "Operation" in this manual.

Caution

Follow the trial run steps of the ODU.

IDU

- The wired/remote controller switch is operating normally.
- The display of the wired/remote controller is normal, the function keys work normally, the room temperature adjustment is normal, and the air flow and direction adjustment are normal.
- The LED indicator is on.
- Water discharge is normal.
- Check the IDUs one by one for normal operation, and the cooling and heating functions are normal without vibration or abnormal sound.

ODU

- There are no vibrations or strange sounds during operation.
- The fan, noise and condensation do not affect the neighbors.
- There is no refrigerant leakage.

Inspection After Installation

To ensure a comfortable indoor environment, please run down through the list to check whether the installation of the air conditioner meets the requirements. Insert a "x" for Fail and a "√" for Pass.

Check Item	Check Criteria	Check Result (Pass/Fail)
Are the IDUs and ODUs securely installed?	The air conditioner does not fall or vibrate, and there is no noise.	
Has the installation of the IDU been completed?	The unit works properly and no parts are burned out.	
Has a leak test been performed?	The cold/hot air is sufficient.	
Is the heat insulation in good condition (refrigerant piping, drainage pipe, and air ducts)?	There is no condensation dripping.	
Were the copper pipes sealed before installation to prevent dust from entering?	The compressor is functional.	
Is the refrigerant piping filled with nitrogen for shielded welding during the welding process (a nitrogen cylinder is on site)?	There is no oxide film on the inner surface of the copper pipe. The system is functional with no major failures.	
Has a water discharge test been performed? Is drainage smooth? Is the connection secure?	There is no water leakage.	
Is the power supply voltage consistent with the specified voltage on the unit nameplate?	The unit works properly and no parts are burned out.	
Are the wires and pipes connected correctly?	The unit works properly and no parts are burned out.	
Is the air conditioner safely grounded?	There is no electric leakage.	
Have wires of the specified size been used?	The unit works properly and no parts are burned out.	
Are the terminal screws securely fastened?	There is no electric shock or fire.	
Are the inlets and outlets of the IDUs and ODUs free of obstruction?	The cold/hot air is sufficient.	
Has the refrigerant piping length and refrigerant charge been recorded?	The amount of refrigerant in the air conditioning system is clear.	
Does the temperature of each room meet the requirements during testing?	Users' comfort needs can be satisfied.	
Have you explained to the user how to operate the unit according to the user manual?	The unit is effective.	
Have you explained to the user how to use and clean the air filter?	The unit is effective.	

Cleaning, Maintenance and After-Sales Service

1 Safety Warning

Warning

For safety reasons, always turn off the air conditioner and turn off the power before cleaning the air conditioner.

Do not disassemble or repair the air conditioner by yourself; otherwise, it may cause fire or other hazards.

Only professional service personnel can carry out the maintenance.

Do not use flammable or explosive materials (such as hair styling agents or pesticides) near the product.

Do not use organic solvents such as paint thinner to clean this product; otherwise, it may cause cracks, electric shock or fire.

Only qualified dealers and professionally qualified electricians can install the optional accessories.

Be sure to use the optional accessories specified by our company.

Improper installation by yourself may result in water leakage, electric shock or fire.

Do not wash the air conditioner with water; otherwise, it may cause an electric shock.

Use a stable standing platform.

2 Cleaning and Maintenance

Cleaning the Louver and Unit Surface

① Clean the cloth in water, wring out the cloth, and gently wipe the unit body.

② If a stain is hard to remove, dip a cloth into neutral detergent and clean the stain.

Caution

Do not use gasoline, benzene, volatile agents, decontamination powder or liquid insecticides. Otherwise, the air outlet or panel may become discolored or deformed.

Do not expose the inside of the IDU to moisture, as it may result in electric shock or fire.

When cleaning the louver with water, do not scrub it violently.

If the air conditioner is used without an air filter, the accumulation of dust in the air conditioner will often cause malfunctions due to the failure to remove dust from the indoor air.

Cleaning the Air Filter

Caution

Air filters can be used to remove dust or other particles from the air, and if clogged, the effectiveness of the air conditioner will be greatly reduced.

Therefore, be sure to clean the air filter frequently when using it for an extended period. If the unit is installed in a place with a lot of dust, it is recommended that you clean the filter once a month.

If excess dirt makes the filter difficult to clean, replace the filter.

Do not remove the air filter unless it is being cleaned; otherwise, it may cause malfunction.

1 Procedure diagram

- 1 Use two hands to hold the panel above the air outlet, open it in the direction of the arrow, and use one hand to hold the panel and the other hand to lift the middle convex part of the filter and pull the filter out downwards.

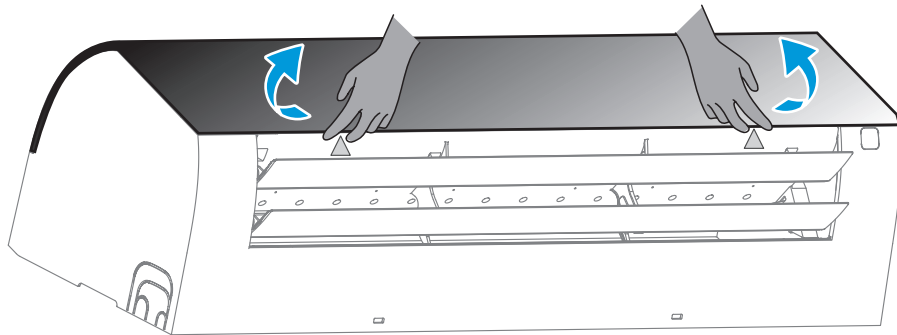

- 2 Clean the filter and dry it in a cool place.

Clean the filter with a vacuum cleaner, with the air inlet side of the filter facing upwards.

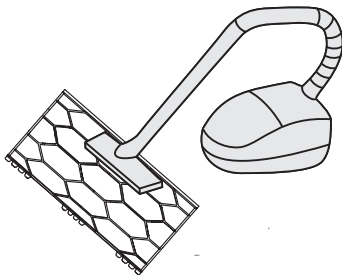

Clean the filter with clean water (except for the activated carbon module), with the air inlet side of the filter facing downwards.

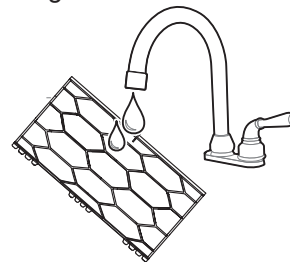

Caution

To avoid deformation of the filter, do not use fire or a burning appliance to dry the filter.

If the filter is heavily soiled, use a soft brush and neutral detergent to clean it, then shake off the water and dry it in a cool place.

Non-professionals should not disassemble, replace or repair the filter.

- 3 Reinstall the filter in the reverse order of the steps above and put the panel back.

During in-depth maintenance, the air conditioner should be cleaned and maintained by professional technicians every 2 to 3 years.

Clean the filter regularly.

When operating in a dusty environment, the air flow and capacity of the filter will decrease. The filter may even become blocked, and the air conditioner performance and indoor air compromised.

Preheat the unit in advance.

When the heating season comes, power on the ODU master unit for preheating more than 4 hours before use. The preheating time depends on the weather temperature. This can make the air conditioner operate more stably and help the refrigeration oil in the air conditioner compressor to maintain the best lubrication state, which can prolong the service life of the compressor.

Complete the following steps before the air conditioner is put out of use for a long period:

1. If the air conditioner is not in use for a long time due to seasonal changes, keep the unit running for 4-5 hours in fan mode until the unit becomes completely dry. Otherwise, it may grow mold indoors and have negative health effects.
2. When not in use for a long time, power off or unplug the power plug to reduce standby power consumption, and wipe the wireless remote controller with a clean soft dry cloth and remove the battery.
3. Turn on the power switch 12 hours before using the air conditioner again. In addition, in seasons when air conditioners are frequently used, keep the power switch on. Otherwise, failures may occur.

Caution

Before the air conditioner is idle for a long time, the internal components of the ODUs should be checked and cleaned regularly. For more details, please contact the local air conditioner customer service center or special technical service department.

Check the return air inlet and outlet of the ODU and IDU after long periods of use to see if they are blocked; if an inlet/outlet is blocked, clean it immediately.

3 Maintenance of Conventional Parts

Disassembly and Installation of Panel and IDU Wiring

1 Disassembly of the Front Panel

There is no need to disassemble the panel frame when confirming the electrical cable distribution and condensed water drainage.

- ① Pull out slightly on the panel from the buckle position on both sides of the unit body.
- ② Take the panel off the buckles along the gap between the panel and the unit body. Remove the panel obliquely upward.
- ③ Hold the two lower ends of the front panel, gently pull the panel and then push the panel upward to remove it.

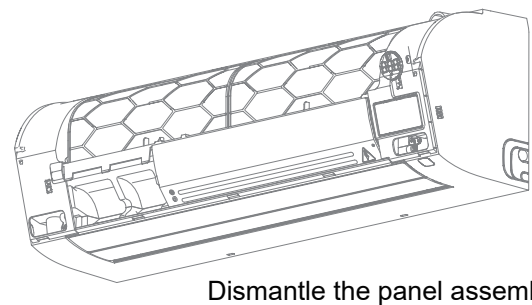
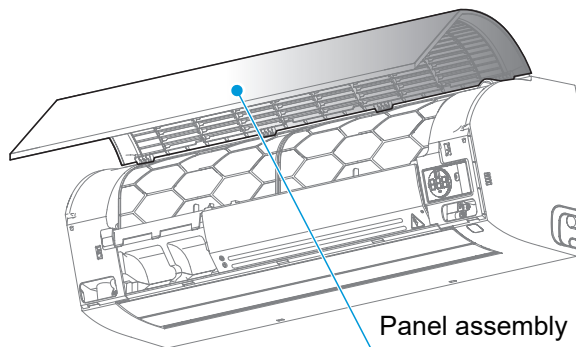

2 IDU wiring

Lead the power cable, ground wire, and signal cable from the back of the indoor unit to the front. For detailed wiring steps, refer to section "Installation Instructions - Electrical Connection".

3 Installation of Front Panel

- ① Insert the upper buckles of the panel into the buckles on the panel frame.
- ② Place the panel and press the buckles.

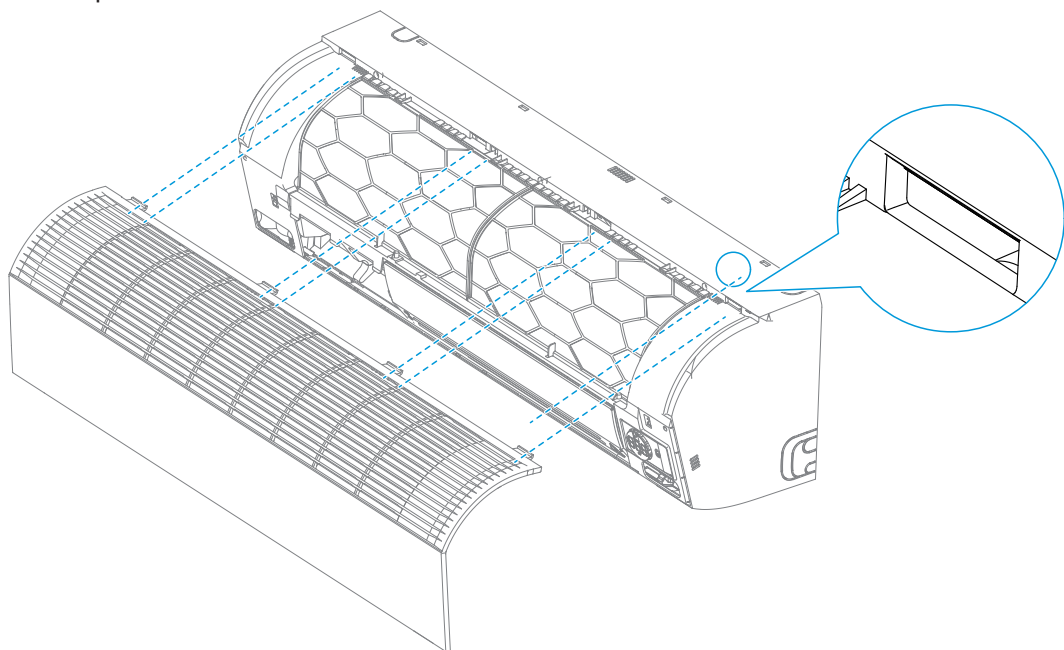

Caution

Make sure that the front buckles of the panel fit the unit well, otherwise condensation and other risks may occur.

Replacement of the Filter

- 1 Open the panel assembly.

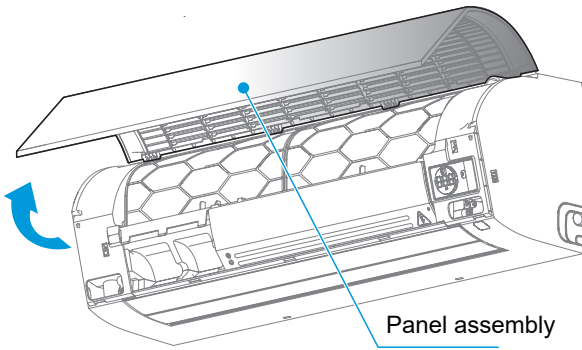

- 2 Remove and replace the filter.

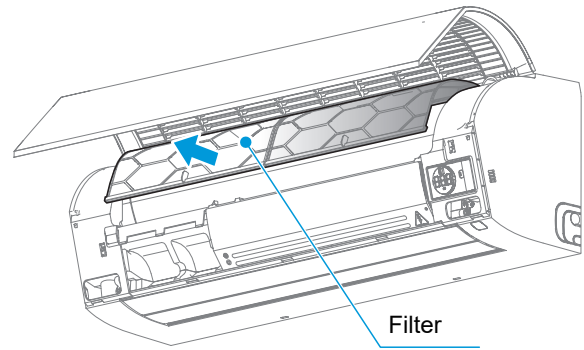

Maintenance of the Electric Control Board

- 1 Dismantle the panel assembly.

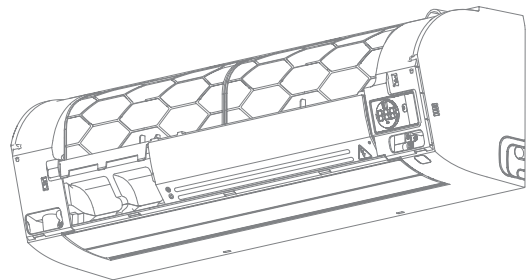
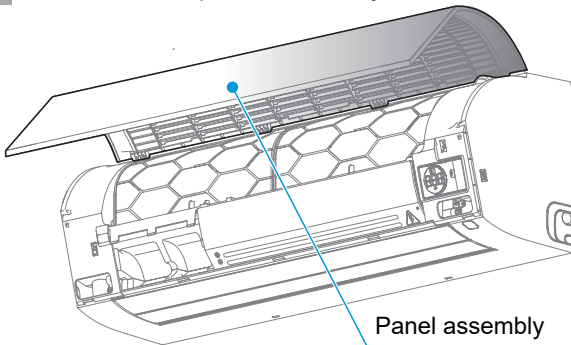

- 2 Loosen the screws on the right side of the electric control box cover and remove the electric control box cover.

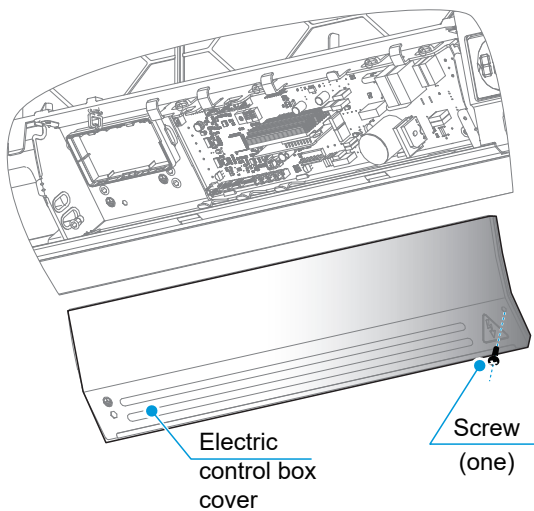

- 3 Loosen the screws inside the electric control box, remove the main control board and start repairing the unit.

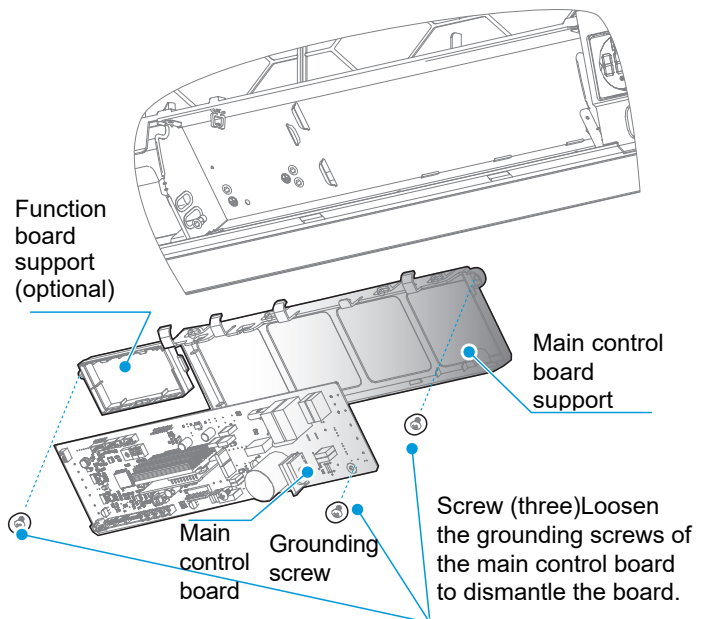

Maintenance of Display Panel

- 1 Follow the steps above to dismantle the panel assembly.
- 2 First remove the display box cover, then remove the display panel and unplug the cable.

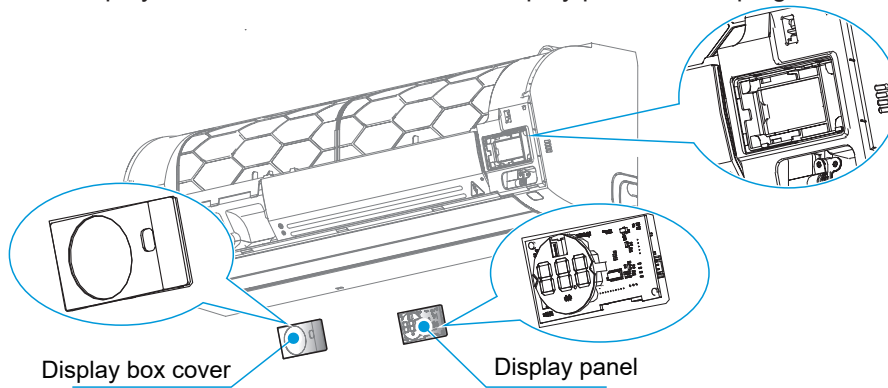

Maintenance of Infrared Human Sensor, Temperature Sensor, Drain Pump and Water Level Switch

- 1 Remove the upper and lower louver near the screw hole, loosen the screws, and then remove the panel frame.

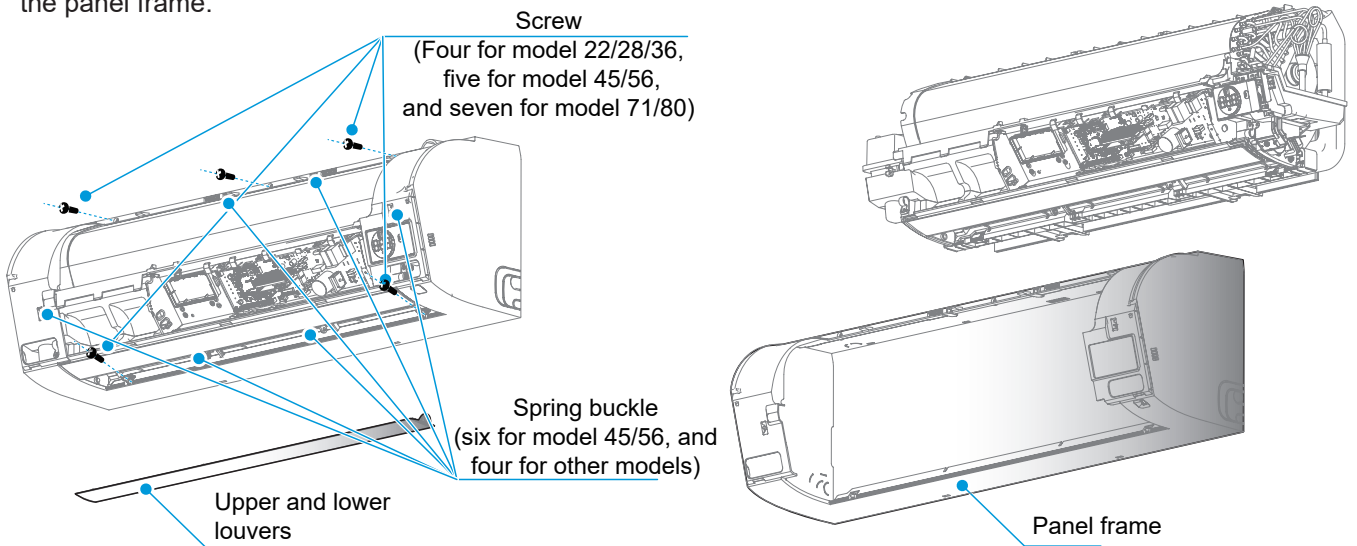

- 2 Take out the infrared human sensor, remove the connecting cable and repair the sensor.

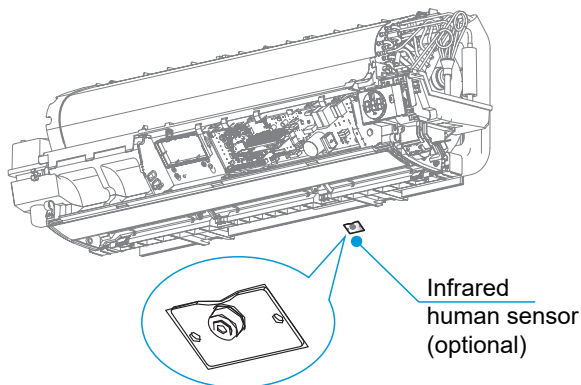

- 3 Pull the temperature sensor out of the buckle or sleeve, pull the plug out of the electric control box and repair the temperature sensor.

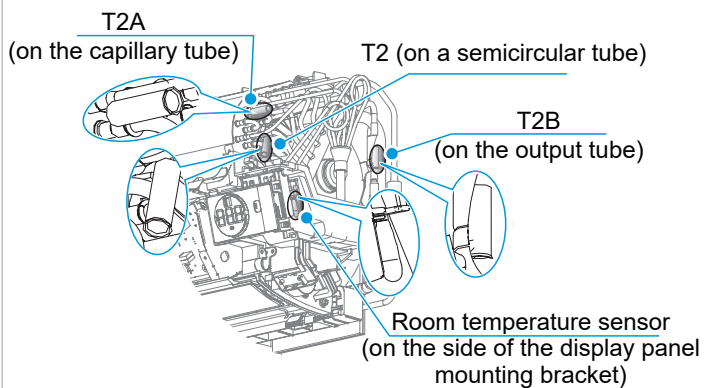

4 Plasma generator (optional):

① Remove the screws (two).

② Pull out the electrode, remove the plasma generator and repair it.

Humidity sensor: Remove the humidity sensor cable from the electric control board, pull out the humidity sensor and repair it.

Electronic expansion valve coil: Remove the electronic expansion valve coil cable from the electric control board, pull out the coil and repair it.

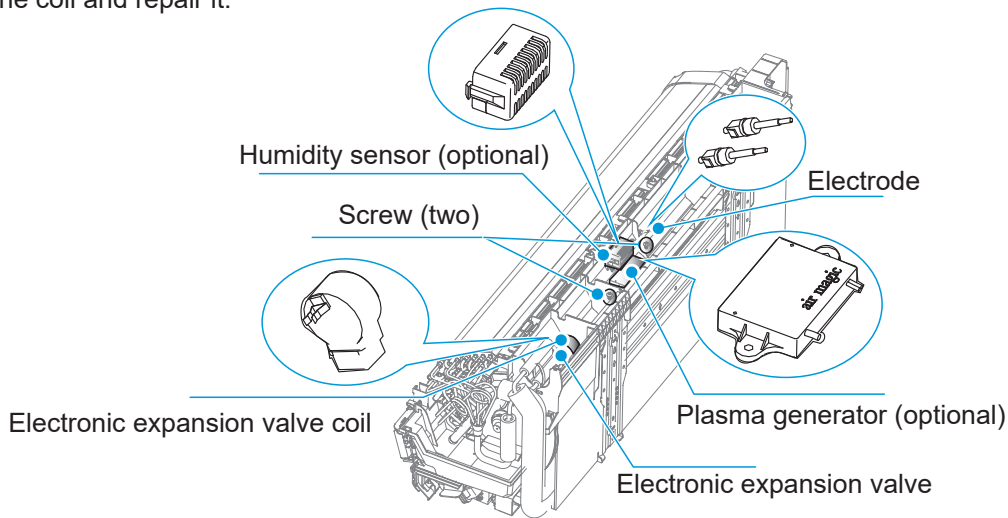

5 Remove the water pump and water level switch cable from the electric control board, ① pull out the drainage pipe from the chassis outlet, ② loosen the two screws fixing the drain pump mounting base, remove the drain pump assembly, ③ loosen the screws securing the drain pump, remove the drain pump to repair it, and ④ remove the water level switch to repair it.

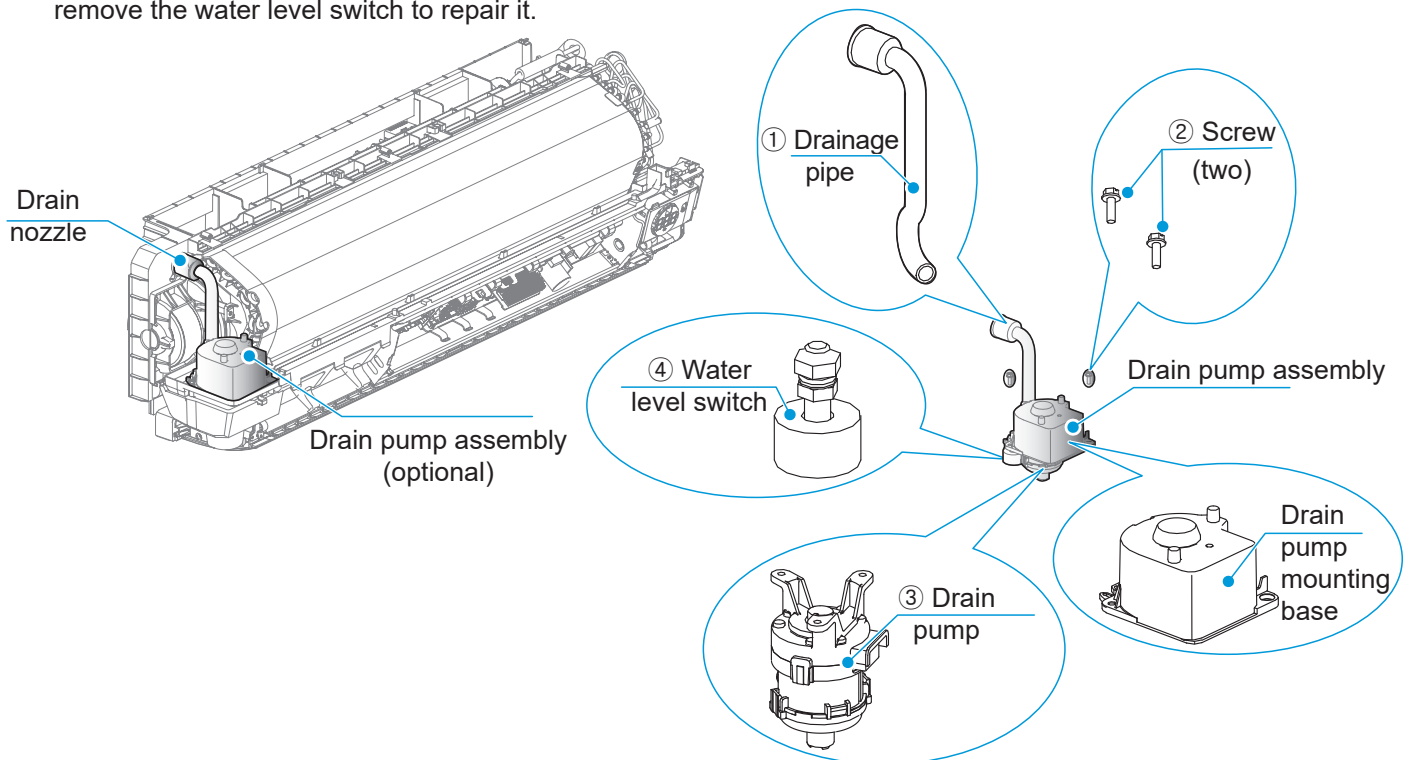

Maintenance of Motor and Wind Wheel

- 1 Pull the plug of the motor, electronic expansion valve and each temperature sensing line out of the electric control board, pull out the drainage pipe from the chassis outlet, push the buckle of the drain pan assembly upward so that the buckle is separated from the chassis, and then pull the drain pan assembly out horizontally. (The 71/80 model needs to remove a screw and support sheet metal as shown before removing the drain pan assembly.)

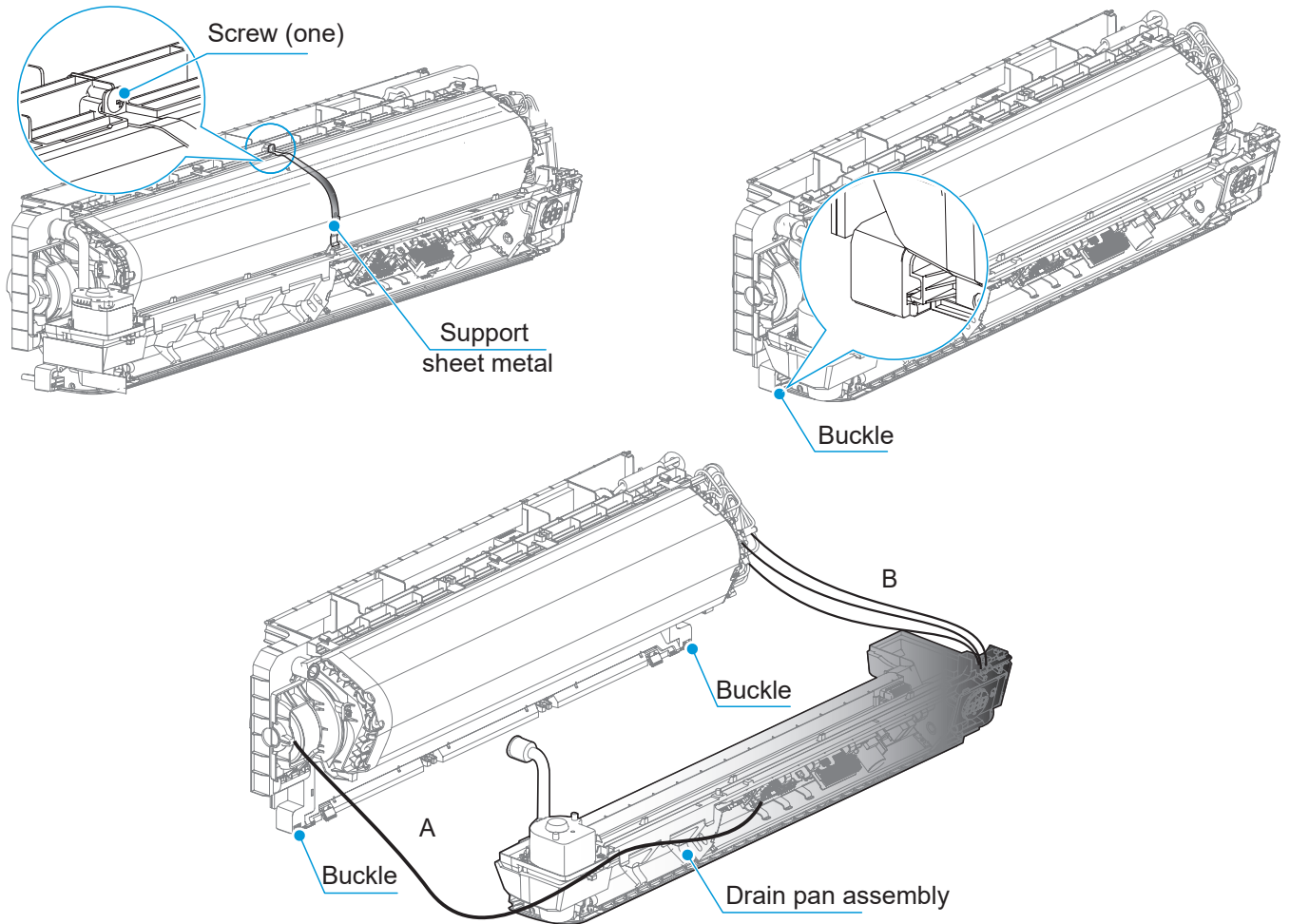

Caution

Dismantle the motor cable at position A before you dismantle the drain pan assembly. The sensor cable at position B may not be removed. Carefully hang the drain pan assembly.

- 2 Lift and pull out the box containing the silver ion deodorizer for maintenance.

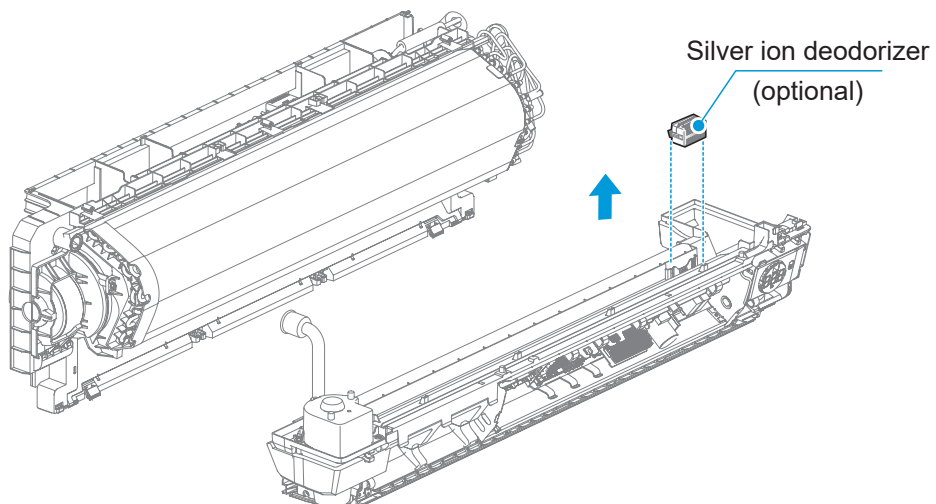

3 Loosen the screw (one), pull the evaporator horizontally a little and hang the evaporator.

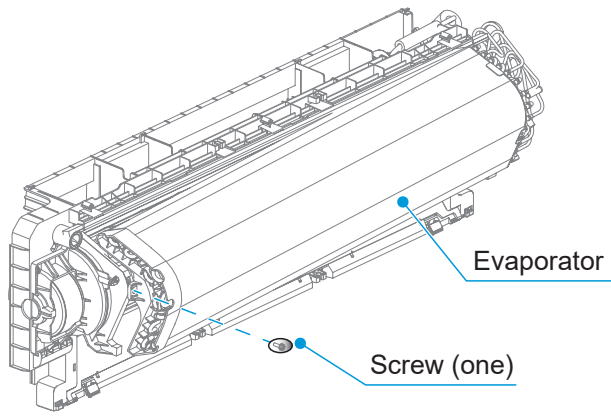

4 Loosen the screws (two), swivel out slightly and take out the motor mounting rack (hold the motor and prevent it from falling). Pull out the motor and wind wheel horizontally.

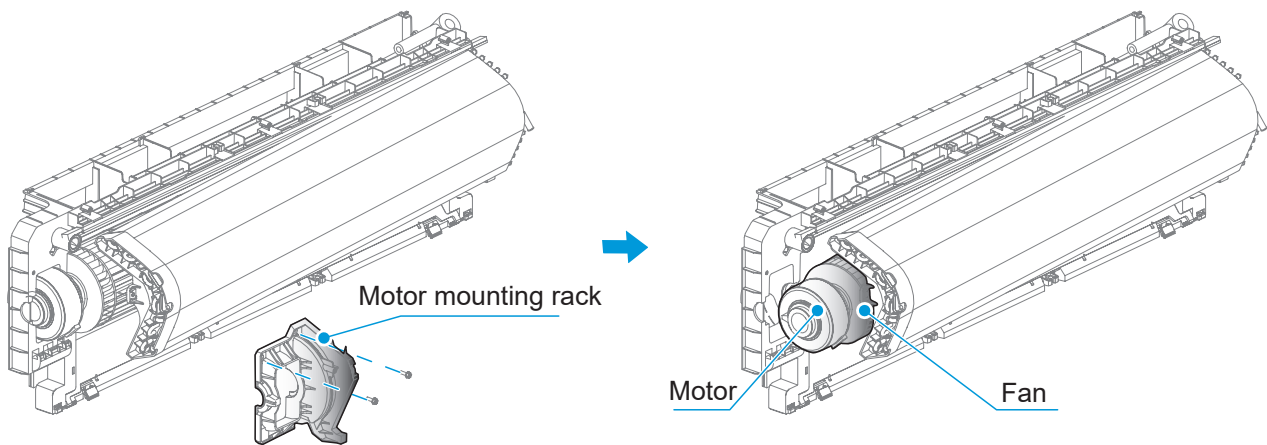

5 Take the motor and wind wheel out horizontally; loosen the screws fixing the motor and wind wheel, and repair the motor and wind wheel.

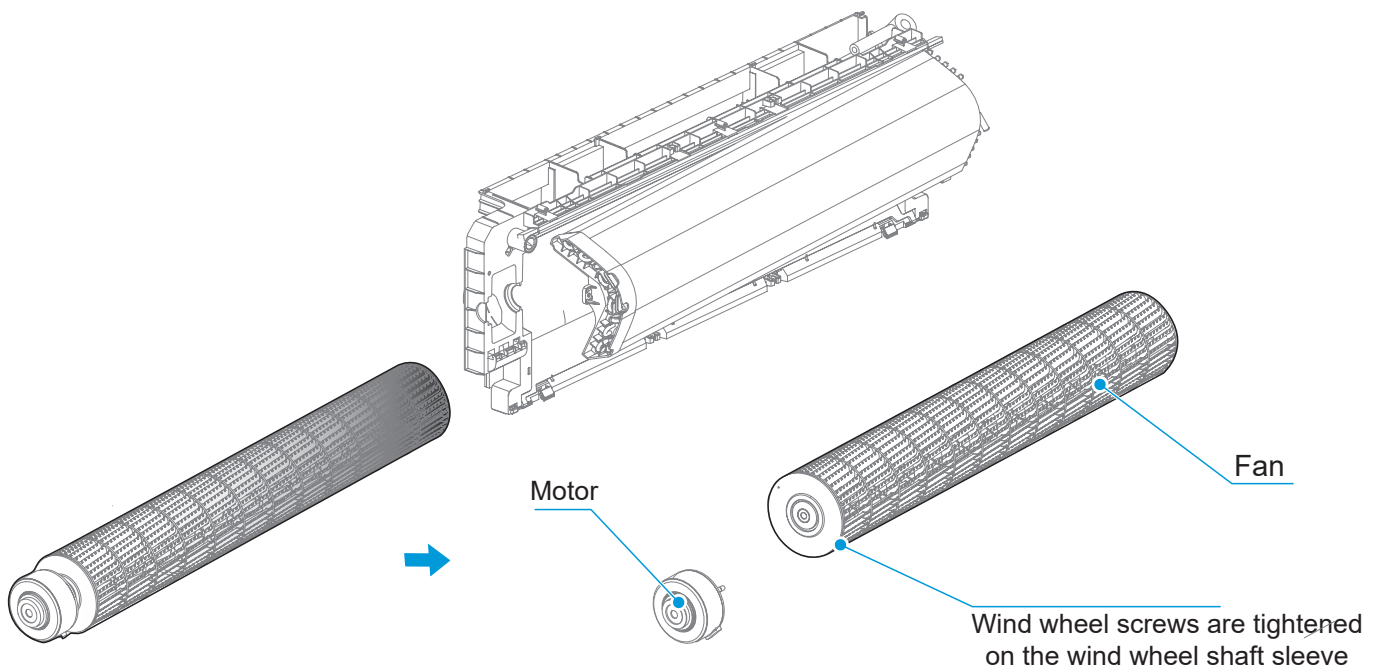

Maintenance of Wind Wheel Bearing

- 1 Follow the steps above to remove the motor and wind wheel; push the wind wheel bearing to remove and repair it.

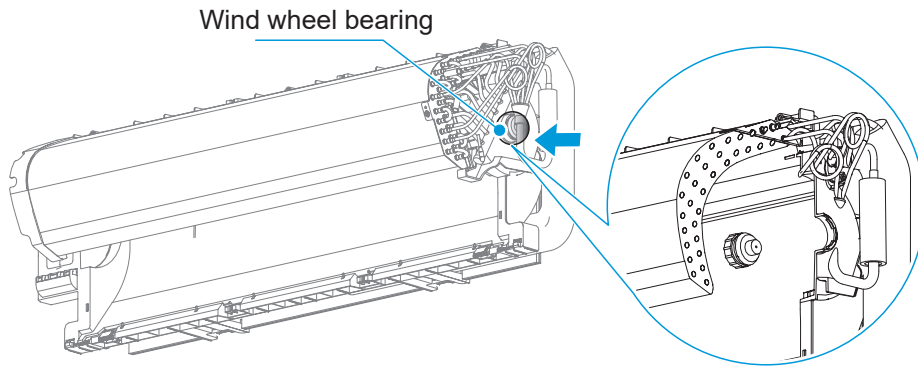

Maintenance of Oscillation Motor

- 1 Follow the steps above to remove the panel frame and upper and lower louvers.

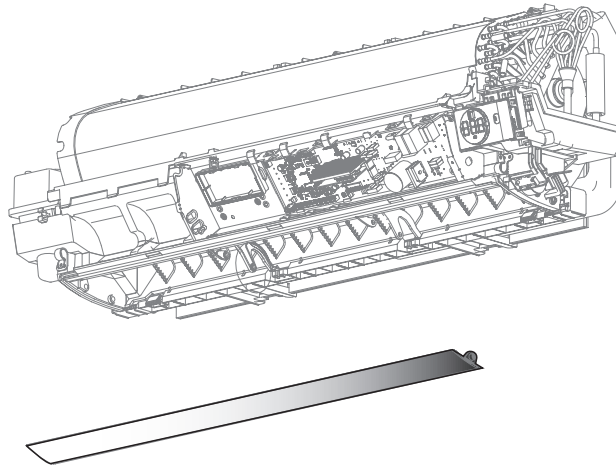

- 2 First loosen the screws (three) to remove the display panel, remove the cable terminal on the oscillation motor, then disconnect the left and right louver rod and the left and right swing motor rod, and take the swing motor and repair it.

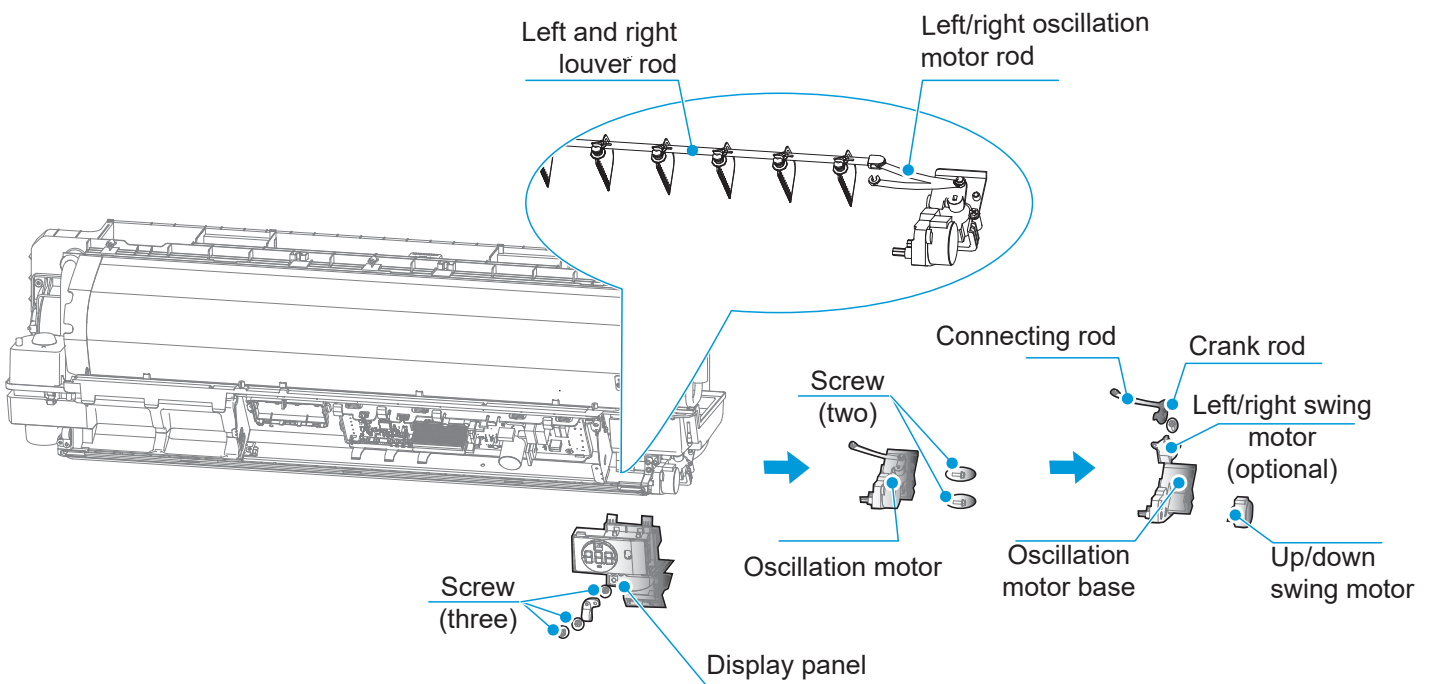

16126000A27243 V1.2

GD Midea Heating & Ventilating
Equipment Co., Ltd.
Penglai Industry Road, Beijiao, Shunde, Foshan,
Guangdong, 528311, P.R. China

此页不做菲林，仅核对使用

印刷技术要求

材质	封面封底为双胶纸120g，内页为双胶纸80g
规格	210*297(双面)
颜色	黑白
其他	胶装

设计更改记录表（仅做说明用，不做菲林）

版本升级	更改人	更改日期	更改主要内容	涉及更改页面 (印刷页码)
V1.0-V1.1	农钰莹	2023.4.23	随基准升级 P22修改参数400-530 P26删除手工弯管 P39修改7.1/8.0kW的参数 P52修改功能扩展板的连接 整本修改 警示标志 P66更改螺钉数量，P68增加示意图	修改CN18的名称
V1.1-V1.2	何淑玉	2023.12.13	随基准更改,整本更改面框图、风轮图	