

# OWNER'S MANUAL

*DC INVERTER FREE*



**This air conditioner comprises an indoor unit, outdoor unit, and a connection pipe.**

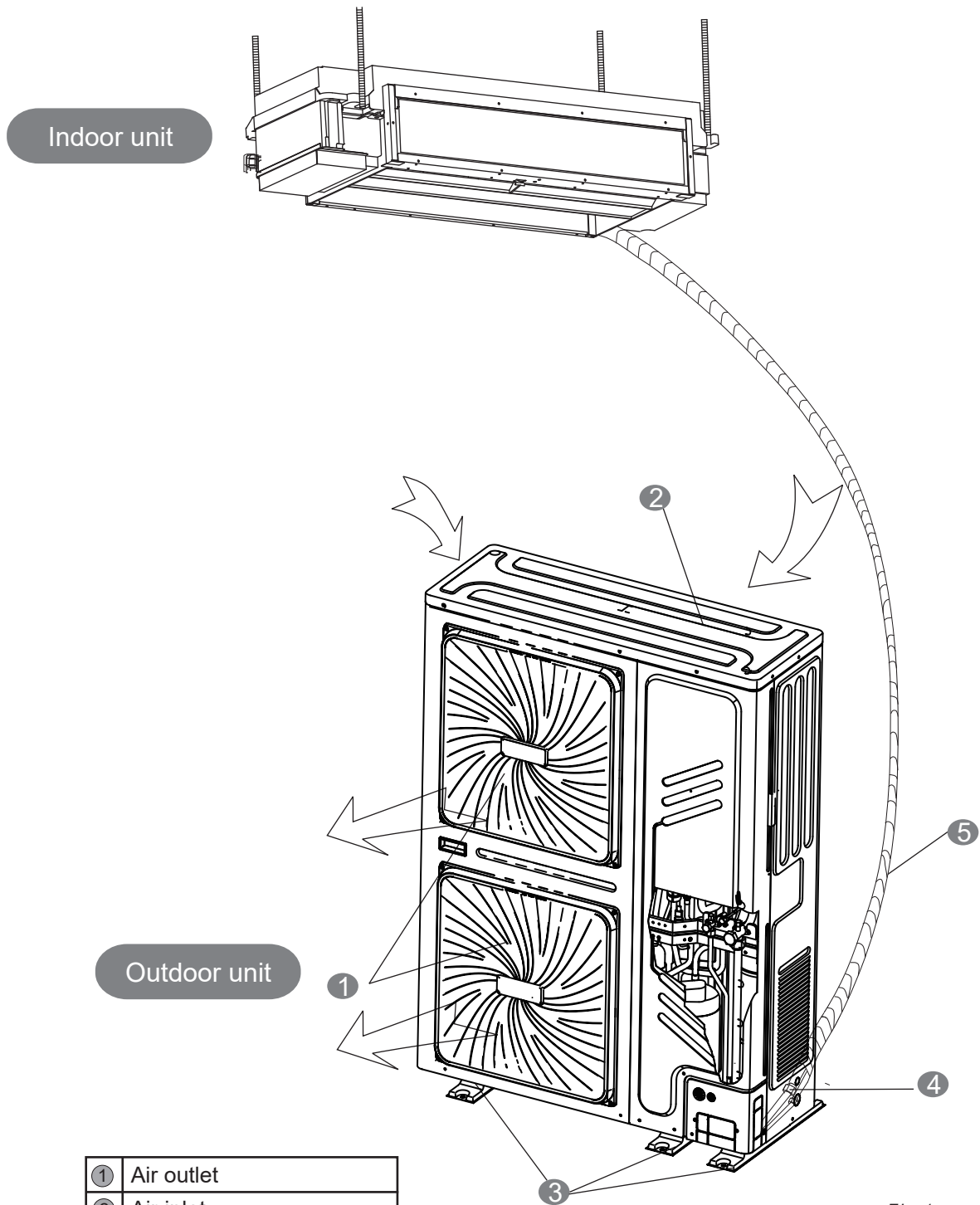

Fig. 1



**NOTE**

All the pictures in this manual are for explanation purpose only. They may be slightly different from the air conditioner you purchased (depend on model). The actual shape shall prevail.

CONTENTS	PAGE
IMPORTANT SAFETY INFORMATION.....	1
OPERATION RANGE.....	2
OPERATION AND PERFORMANCE.....	3
MALFUNCTION CODE OF OUTDOOR UNIT .....	4
FOLLOWING SYMPTOMS ARE NOT AIR CONDITIONER TROUBLES.....	5
TROUBLESHOOTING.....	5
MAINTENANCE AND PEPAIR.....	7

## 1. IMPORTANT SAFETY INFORMATION

To prevent injury to the user or other people and property damage, the following instructions must be followed. Incorrect operation due to ignoring of instructions may cause harm or damage.

The safety precautions listed here are divided into two categories. In either case, important safety information is listed which must be read carefully.



### WARNING

Failure to observe a warning may result in death. The appliance shall be installed in accordance with national wiring regulations.



### CAUTION

Failure to observe a caution may result in injury or damage to the equipment.



### WARNING

**Ask your dealer for installation of the air conditioner.**  
Incomplete installation performed by yourself may result in a water leakage, electric shock, and fire.

**Ask your dealer for improvement, repair, and maintenance.**  
Incomplete improvement, repair, and maintenance may result in a water leakage, electric shock, and fire.

**In order to avoid electric shock, fire or injury, or if you detect any abnormality such as smell of fire, turn off the power supply and call your dealer for instructions.**

**Never let the indoor unit or the remote controller get wet.**  
It may cause an electric shock or a fire.

**Never press the button of the remote controller with a hard, pointed object.**  
The remote controller may be damaged.

**Never replace a fuse with that of wrong rated current or other wires when a fuse blows out.**  
Use of wire or copper wire may cause the unit to break down or cause a fire.

**It is not good for your health to expose your body to the air flow for a long time.**

where oil gas, salty air (near the coast), caustic gas (the sulfide in hot spring) exist, otherwise it may damage the unit and shorten the life span of the machine. If the situations above can't be avoided, choose an anticorrosive model.

**Do not insert fingers, rods or other objects into the air inlet or outlet.**  
When the fan is rotating at high speed, it will cause injury.

**Never use a flammable spray such as hair spray, lacquer or paint near the unit.**  
It may cause a fire.

**Never touch the air outlet or the horizontal blades while the swing flap is in operation.**  
Fingers may become caught or the unit may break down.

**Never put any objects into the air inlet or outlet.**  
Objects touching the fan at high speed can be dangerous.

**Never inspect or service the unit by yourself.**  
Ask a qualified service person to perform this work.

**Do not dispose this product as unsorted municipal waste. Collection of such waste separately for special treatment is necessary.**  
Do not dispose of electrical appliances as unsorted municipal waste, use separate collection facilities.



Contact your local government for information regarding the connection systems available.

**If electrical appliances are disposed of in landfills or dumps, hazardous substances can leak into the ground and get into the food chain, damaging your health and well-being.**

**To prevent refrigerant leak, contact your dealer.**  
When the system is installed and runs in a small room, it is required to keep the concentration of the refrigerant, if by any chance coming out, below the limit. Otherwise, oxygen in the room may be affected, resulting in a serious accident.

**The refrigerant in the air conditioner is safe and normally does not leak.**  
If the refrigerant leaks in the room, contact with a fire of a burner, a heater or a cooker may result in a harmful gas.

**Turn off any combustible heating devices, ventilate the room, and contact the dealer where you purchased the unit.**  
Do not use the air conditioner until a service person confirms that the portion where the refrigerant leaks is repaired.

**If the supply cord is damaged, it must be replaced by the manufacturer, its service agent or similarly qualified person in order to avoid a hazard.**



### CAUTION

**Do not use the air conditioner for other purposes.**  
In order to avoid any quality deterioration, do not use the unit for cooling precision instruments, food, plants, animals or works of art.

**Before cleaning, be sure to stop the operation, turn the breaker off or pull out the supply cord.**  
Otherwise, an electric shock and injury may result.

**In order to avoid electric shock or fire, make sure that an earth leak detector is installed.**

**Be sure the air conditioner is grounded.**  
In order to avoid electric shock, make sure that the unit is grounded and that the earth wire is not connected to gas or water pipe, lightning conductor or telephone earth wire.

**In order to avoid injury, do not remove the fan guard of the outdoor unit.**

**Do not operate the air conditioner with a wet hand.**  
An electric shock may happen.

**Do not touch the heat exchanger fins.**  
These fins are sharp and could result in cutting injuries.

**Do not place items which might be damaged by moisture under the indoor unit.**  
Condensation may form if the humidity is above 80%, the drain outlet is blocked or the filter is polluted.

**After a long use, check the unit stand and fitting for damage.**  
If damaged, the unit may fall and result in injury.

**To avoid oxygen deficiency, ventilate the room sufficiently if equipment with burner is used together with the air conditioner.**

**Arrange the drain hose to ensure smooth drainage.**  
Incomplete drainage may cause wetting of the building, furniture etc.

**Never touch the internal parts of the controller.**  
Do not remove the front panel. Some parts inside are dangerous to touch, and a machine trouble may happen.

**Never expose little children, plants or animals directly to the air flow.**  
Adverse influence to little children, animals and plants may result.

**Do not allow a child to mount on the outdoor unit or avoid placing any object on it.**  
Falling or tumbling may result in injury.

**Do not operate the air conditioner when using a room fumigation - type insecticide.**  
Failure to observe could cause the chemicals to become deposited in the unit, which could endanger the health of those who are hypersensitive to chemicals.

**Do not place appliances which produce open fire in places exposed to the air flow from the unit or under the indoor unit.**  
It may cause incomplete combustion or deformation of the unit due to the heat.

**Do not install the air conditioner at any place where flammable gas may leak out.**  
If the gas leaks out and stays around the air conditioner, a fire may break out.

**This appliance can be used by children age from 8 years and above and persons with reduced physical, sensory or mental capabilities or lack of experience and knowledge if they have been given supervision or instruction concerning use of the appliance in a safe way and understand the hazards involved, children should not play with This appliance. Cleaning and user maintenance should not be made by children without supervision.**

**When capacity of indoor unit greater than the sum of 100%, capacity of indoor unit will be attenuated.**

**When capacity of indoor unit greater than or equal to the sum of 120%, in order to ensure the effectiveness of machine, and then try to open the indoor units at different time.**

**The outdoor unit window-shades should be periodic cleaning in case of being jammed.**  
This window-shapes is heat dissipation outlet of components, if being jammed will cause the components shorten their service life spans because of overheated for a long time.

**The temperature of refrigerant circuit will be high, please keep the interconnection cable away from the copper tube.**

**Poor environmental conditions, the appliance should be maintained a month and a half or so; if the environment condition is good, may be extended appropriately maintenance cycle.**

**This appliance can be used by children aged from 8 years and above and person with reduced physical, sensory or mental capabilities or lack of experience and knowledge if they have been given supervision or instruction concerning use of the appliance in a safe way and understand the hazards involved. Children shall not play with the appliance. Cleaning and user maintenance shall not be made by children without supervision.**

## 2. OPERATION RANGE

Use the system in the following temperature and pressure for safe and effective operation. The Max operation temperature for the air conditioner. (Cooling/Heating)

Table 2-1

Temperature Mode	Outdoor temperature	Room temperature
Cooling operation	-5°C~55°C	17°C~32°C
Heating operating	-20°C~27°C	15°C~27°C

Mode PS	High	Low
Parameter	4.2MP	3.4MP



### NOTE

1. If air conditioner is used outside the above conditions, it may cause the unit to function abnormally.
2. The phenomenon is normal that the surface of air conditioning may condense water when the relative larger humidity in room, please close the door and window.
3. Optimum performance will be achieved within these operating temperature range.
4. The A-weighted sound pressure level is below 70 dB.
5. The temperature sound below 55°C during transporting.
6. The sound pressure level is below 70 dB(A)

## 2.1 Short-circuit ratio statement

We declare the model MVi-(200,224,260,280,335)WV2GN1(A) This equipment complies with IEC 61000-3-12 provided that the short-circuit power Ssc is greater than or equal to 6280232W or 6401472W at the interface point between the user's supply and the public system. It is the responsibility of the installer or user of the equipment to ensure, by consultation with the distribution network operator if necessary, that the equipment is connected only to a supply with a short-circuit power Ssc greater than or equal to 6280232W or 6401472W.

Table 2-2

Power Mode	short-circuit power Ssc(w)
20-28	6280232
33.5	6401472

## 3 OPERATION AND PERFORMANCE

### 3.1 Protection Equipment

This Protection Equipment will enable the Air Conditioner to stop when the Air Conditioner is to be directed running compulsively.

When the Protection Equipment is activated, the Operation Indicator still lights while the Air Conditioner is not running. But the Check Indicator Lights.

The protection equipment may be activated in following conditions:

#### ■ Cooling Operation

- The air inlet or air outlet of outdoor unit is blocked.
- Strong wind is Continuously blowing to the air outlet of the outdoor unit.

#### ■ Heating Operation

- Too much dust and rubbish adhere to the dust filter in the indoor unit
- The air outlet of indoor unit is choked



#### NOTE

When the protection equipment starts, please shut down the manual power switch, and restart operation after problem is solved.

### 3.2 About power cut

- If power is cut during operation, stop all the operation immediately.
- Power comes again. The lamp on the display panel of indoor unit flashes. And then unit will auto-restart.
- Mishandling in operation:  
If mishandling happens because of lighting or mobile wireless, please shut off the manual power switch, and turn on again, then push the ON/OFF button.

### 3.3 Heating capacity

- The heating operation is a heat-pump process that heat will be absorbed from outdoor air and released in doors. Once the outdoor temperature is decreased, heating capacity decreased correspondingly.

- Other heating equipment is suggested to be used together when outdoor temperature is too low.
- In some extreme cold upland that buy another indoor unit equipped electrical heater will obtain better performance.(Refer to indoor unit owner's manual for details)



#### NOTE

1. The motor in Indoor Unit will continue running for 20~30 seconds for to remove residual heat when the Indoor Unit receiving OFF command during heating operation.
2. If the air conditioner malfunction occurs because of disturb, please reconnect the air conditioner to power, then turn on it again.

### 3.4 Five-minute protection feature

- A protection feature prevents the air conditioner from being activated for approximately 5 minutes when it restarts immediately after operation.

### 3.5 Cooling and heating operation

- The indoor unit of the intelligent inverter centralized air conditioner can be controlled solely, but the indoor unit in the same system can not run cooling and heating at the same time.
- When the Cooling and Heating operation confront with each other, the Indoor Unit which are running on Cooling Mode would stop and there will be Standby or No Priority displayed in the Control Panel. Those Indoor Units which are running on Heating Mode will run continuously.
- If the Air Conditioner Administrator has set running mode, then the air conditioner can not run on modes other than the presetted. Standby or No Priority will be displayed in the Control Panel.

### 3.6 Features of heating operation

- Warm air will not be blown out immediately at the beginning of the heating operation, 3~5 minutes ago (depends on the indoor and outdoor temperature), until the indoor heat exchanger become hot, then blows out warm air.
- During operation, the fan motor in the outdoor unit may stop running under high temperature.
- During Fan Operation, if other Indoor Units are running on Heating Mode, the fan may stop in order to prevent sending heat wind.

### 3.7 Defrost in the heating operation

- During heating operation, outdoor unit sometimes will frost. To increase efficiency, the unit will start defrosting automatically (about 2~10 minutes), and then water will be drained out from outdoor unit.
- During defrosting, both the fan motors in the outdoor unit and indoor unit will stop running.

## 4 MALFUNCTION CODE OF OUTDOOR UNIT

Table 4-1

No.	Failure or Protection Type	Recovery Mode	Fault Code
1	Communication error between main board and compressor drive board	Recoverable	H0
2	DC bus voltage error	Recoverable	F1
3	Inverter-module protection	Recoverable	H4
4	3 times of P2 protection in 30 minutes	Irrecoverable	H5
5	Qty. of indoor units mismatching	Irrecoverable	H7
6	High pressure sensor fault	Recoverable	H8
7	M-HOME for the indoor and outdoor units does not match	Irrecoverable	HF
8	Phase sequence error	Recoverable	E1
9	Communication error between indoor and master unit	Recoverable	E2
10	T3 & T4 temperature sensor error	Recoverable	E4
11	Abnormal power supply voltage	Recoverable	E5
12	DC fan motor error	Recoverable	E6
13	Discharge temperature sensor error	Recoverable	E7
14	TL sensor error	Recoverable	EH
15	E6 protection appears 6 times in 1 hour	Irrecoverable	Eb
16	Inverter module Temp. protection	Recoverable	PL
17	High pressure protection	Recoverable	P1
18	Low pressure protection	Recoverable	P2
19	Compressor current protection	Recoverable	P3
20	Discharge Temp. protection	Recoverable	P4
21	High Temp. protection of condenser	Recoverable	P5
22	Typhoon protection	Recoverable	P8
23	Inverter compressor module error	Recoverable	L0
24	DC bus low voltage protection	Recoverable	L1
25	DC bus high voltage protection	Recoverable	L2
26	MCE error	Recoverable	L4
27	Zero speed protection	Recoverable	L5
28	Phase sequence protection	Recoverable	L7
29	Compressor frequency variation greater than 15Hz within one second protection	Recoverable	L8
30	Actual compressor frequency differs from target frequency by more than 15Hz protection	Recoverable	L9
31	PED protection board error	Recoverable	bH
32	High pressure switch protection on driver board	Recoverable	bL

### Display Function Instruction

1. When stand by, LED displaying the amount of indoor units online which communicate with outdoor units.
2. When operation, LED displaying frequency value of compressor.
3. When defrost, LED displaying "dF".
4. The power cord type designation is H07RN-F.

## 5. FOLLOWING SYMPTOMS ARE NOT AIR CONDITIONER TROUBLES

### Symptom 1: The system does not operate

- The air conditioner does not start immediately after the ON/OFF button on the remote controller is pressed. If the operation lamp lights, the system is in normal condition. To prevent overloading of the compressor motor, the air conditioner starts 5 minutes after it is turned ON.
- If the operation lamp and the "PRE-DEF indicator (cooling and heating type) or fan only indicator (cooling only type)" light, it means you choose the heating model. When just starting, if the compressor has not started, the indoor unit appears "anti cold wind" protection because of its overflow outlet temperature.

### Symptom 2: Change into the fan mode during cooling mode

- In order to prevent the indoor evaporator frosting, the system will change into fan mode automatically, restore to the cooling mode after soon.
- When the room temperature drops to the set temperature, the compressor goes off and the indoor unit changes to fan mode; when the temperature rises up, the compressor starts again. It is same in the heating mode.

### Symptom 3: White mist comes out of a unit

#### Symptom 3.1: Indoor unit

- When humidity is high during cooling operation. If the interior of an indoor unit is extremely contaminated, the temperature distribution inside a room becomes uneven. It is necessary to clean the interior of the indoor unit. Ask your dealer for details on cleaning the unit. This operation requires a qualified service person.

#### Symptom 3.2: Indoor unit, outdoor unit

- When the system is changed over to heating operation after defrost operation. Moisture generated by defrost becomes steam and is exhausted.

### Sptom 4: Noise of air conditioners cooling

#### Symptom 4.1: Indoor unit

- A continuous low "shah" sound is heard when the system is in cooling operation or at a stop. When the drain pump (optional accessories) is in operation, this noise is heard.
- A "pishi-pishi" squeaking sound is heard when the system stops after heating operation. Expansion and contraction of plastic parts caused by temperature change make this noise.

#### Symptom 4.2: Indoor unit, outdoor unit

- A continuous low hissing sound is heard when the system is in operation. This is the sound of refrigerant gas flowing through both indoor and outdoor units.
- A hissing sound which is heard at the start or immediately after stopping operation or defrost operation. This is the noise of refrigerant caused by flow stop or flow change.

#### Symptom 4.3: Outdoor unit

- When the tone of operating noise changes. This noise is caused by the change of frequency.

### Symptom 5: Dust comes out of the unit

- When the unit is used for the first time in a long time. This is because dust has gotten into the unit.

### Symptom 6: The units can give off odours

- The unit can absorb the smell of rooms, furniture, cigarettes, etc., and then emit it again.

### Symptom 7: The outdoor unit fan does not spin.

- During operation. The speed of the fan is controlled in order to optimize product operation.

## 6. TROUBLESHOOTING

### 6.1. Troubles and causes of air conditioner

If one of the following malfunctions occur, stop operation, shut off the power, and contact with your dealer.

- The operation lamp is flashing rapidly (twice every second). This lamp is still flashing rapidly after turn off the power and turn on again.
- Remote controller receives malfunction or the button does not work well.
- A safety device such as a fuse, a breaker frequently actuates.
- Obstacles and water enter the unit.
- Water leaks from indoor unit.
- Other malfunctions.

If the system does not properly operate except the above mentioned cases or the above mentioned malfunctions is evident, investigate the system according to the following procedures. (see in Table 6-1)



Table 6-1

Symptoms	Causes	Solution
Unit does not start	<ul style="list-style-type: none"> <li>Power failure.</li> <li>Power switch is off.</li> <li>Fuse of power switch may have burned.</li> <li>Batteries of remote controller exhausted or other problem of controller.</li> </ul>	<ul style="list-style-type: none"> <li>Wait for the comeback of power.</li> <li>Switch on the power.</li> <li>ReplLocation:</li> <li>Replace the batterises or check the controller.</li> </ul>
Air flowing normally but completely can't cooling	<ul style="list-style-type: none"> <li>Temperature is not set correctly.</li> <li>Be in 3 minutes protection of compressor.</li> </ul>	<ul style="list-style-type: none"> <li>Set the temperature properly.</li> <li>Wait.</li> </ul>
Units start or stop frequently	<ul style="list-style-type: none"> <li>Refrigerant is too little or too much.</li> <li>Air or no concreting gas in the refrigerating circuit.</li> <li>Compressor is malfunction.</li> <li>Voltage is too high or too low.</li> <li>System circuit is blocked.</li> </ul>	<ul style="list-style-type: none"> <li>Check leakage, and rightly recharge refrigerant.</li> <li>Vacuum and recharge refrigerant.</li> <li>Maintenance or change compressor.</li> <li>Install manostat.</li> <li>Find reasons and solution.</li> </ul>
Low cooling effect	<ul style="list-style-type: none"> <li>Outdoor unit and indoor unit heat exchanger is dirty.</li> <li>The air filter is dirty.</li> <li>Inlet/outlet of indoor/outdoor units is blocked.</li> <li>Doors and windows are open</li> <li>Sunlight directly shine.</li> <li>Too much heat resource.</li> <li>Outdoor temp. is too high.</li> <li>Leakage of refrigerant or lack of refrigerant.</li> </ul>	<ul style="list-style-type: none"> <li>Clean the heat exchanger.</li> <li>Clean the air filter.</li> <li>Eliminate all dirties and make air smooth.</li> <li>Close doors and windows.</li> <li>Make curtains in order to shelter from sunshine.</li> <li>Reduce heat source.</li> <li>AC cooling capacity reduces (normal).</li> <li>Check leakage and rightly recharge refrigerant.</li> </ul>
Low heating effect	<ul style="list-style-type: none"> <li>Outdoor temperature is lower than 7°C</li> <li>Doors and windows not completely closed.</li> <li>Leakage of refrigerant or lack of refrigerant.</li> </ul>	<ul style="list-style-type: none"> <li>Use heating device.</li> <li>Close doors and windows.</li> <li>Check leakage and rightly recharge refrigerant.</li> </ul>

## 6.2 Troubles and causes of remote controller

Before asking for serving or repairing , check the following points.

(see in Table 6-2)

Table 6-2

Symptoms	Causes	Solution
The fan speed can not be changed.	<ul style="list-style-type: none"> <li>● Check whether the MODE indicated on the display is "AUTO"</li> </ul>	When the automatic mode is selected, the air conditioner will automatically change the fan speed.
	<ul style="list-style-type: none"> <li>● Check whether the MODE indicated on the display is "DRY"</li> </ul>	When dry operation is selected, the air conditioner automatically change the fan speed. The fan speed can be selected during "COOL" , "FAN ONLY", and "HEAT"
The remote controller signal is not transmitted even when the ON/OFF button is pushed.	<ul style="list-style-type: none"> <li>● Check whether the batteries in the remote controller are exhausted.</li> </ul>	The power supply is off.
The TEMP. indicator does not come on.	<ul style="list-style-type: none"> <li>● Check whether the MODE indicated on the display is FAN ONLY</li> </ul>	The temperature cannot be set during FAN mode.
The indication on the display disappears after a lapse of time.	<ul style="list-style-type: none"> <li>● Check whether the timer operation has come to an end when the TIMER OFF is indicated on the display.</li> </ul>	The air conditioner operation will stop up to the set time
The TIMER ON indicator goes off after a lapse of certain time.	<ul style="list-style-type: none"> <li>● Check whether the timer operation is started when the TIMER ON is indicated on the display.</li> </ul>	Up to the set time, the air conditioner will automatically start and the appropriate indicator will go off.
No receiving tone sounds from the indoor unit even when the ON/OFF button is pressed.	<ul style="list-style-type: none"> <li>● Check whether the signal transmitter of the remote controller is properly directed to the infrared signal receiver of the indoor unit when the ON/OFF button is pressed.</li> </ul>	Directly transmit the signal transmitter of the remote controller to the infrared signal receiver of the indoor unit, and then repeatedly push the ON/OFF button twice.

## 7 MAINTENANCE AND REPAIR



### Note

Do not check or repair the unit on your own. Please get relevant professionals to conduct any check or repairs.  
Do not use substances like gasoline, diluent, and chemical dust cloth to wipe the operations panel of the controller. This may remove the surface layer of the controller. If the unit is dirty, immerse a cloth in diluted and neutral detergent, squeeze it dry, and then use it to clean the panel. Finally, wipe it with a dry cloth.



### Warning

When the fuse melts, do not use any unspecified fuse or other wire to replace the original fuse. The use of electrical wires or copper wires may cause the unit to malfunction or cause a fire.



### Warning

Do not insert fingers, sticks, or other items into the air inlet or outlet. Do not remove the fan mesh cover. When the fan rotates at a high speed, it may cause bodily injury.  
It is very dangerous to check the unit when the fan is rotating. Make sure you turn off the main switch before any maintenance work begins.  
Do check the supporting and base structure of the unit for any damages after a long period of use. The unit may drop and cause personal injury if there is any damage.  
Please release pressure before disassembly.

## 7.1 Maintenance after Unit has been Shut Down for a Long Period

For example, in early summer or winter.

- Check and remove all objects that may clog the air inlets and outlets of the indoor and outdoor units.
- Clean the air filter and external shell of the unit. Please contact the installation or maintenance personnel. The installation/operation manual of the indoor unit includes maintenance tips and cleaning procedures. Make sure that the clean air filter is installed in its original position.
- Turn on the main power supply 12 hours before this unit is operated in order to ensure that the unit runs smoothly. The user interface is displayed once the power is turned on.

## 7.2 Maintenance Before Unit is Shut Down for a Long Period

For example, at the end of winter and summer.

- Run the indoor unit in the fan mode for about half a day to dry the internal parts of the unit.
- Turn off the power supply.
- Clean the air filter and external shell of the unit. Please contact the installation or maintenance personnel to clean the air filter and external shell of the indoor unit. The installation/operation manual of the specialized indoor unit includes maintenance tips and cleaning procedures. Make sure that the clean air filter is installed in its original position.

## 7.3 About the Refrigerant

This product contains fluorinated greenhouse gases as stipulated in the Kyoto Protocol. Do not discharge the gas into the atmosphere.

Based on the applicable law, the refrigerant must be checked regularly for leakages. Please contact the installation personnel for more information.



### Warning

The refrigerant in the air conditioner is relatively safer, and usually does not leak. If the refrigerant leaks, and comes in contact with burning objects in the room, it will produce harmful gases.

Shut down any flammable heating device, ventilate the room and contact the agent of the unit immediately.

Do not use the air conditioner again until the maintenance personnel has confirmed that the refrigerant leakage has been sufficiently resolved.



### Warning

The partial units shall only be connected to an appliance suitable for the same refrigerant.

This unit is a partial unit air conditioner, complying with partial unit requirements of this International Standard, and must only be connected to other units that have been confirmed as complying to corresponding partial unit requirements of this International Standard.

### 7.3.1 Important information for the refrigerant

This product has the fluorinated gas, it is forbidden to release to air.

Refrigerant type: R410A/8Kg

Volume of GWP: 2088; tonnes CO2 equivalent

GWP=Global Warming Potential

Attention:

Frequency of Refrigerant Leak Checks

- For equipment that contains fluorinated greenhouse gases in quantities of 5 tonnes of CO2 equivalent or more, but of less than 50 tonnes of CO2 equipment, at least every 12 months, or where a leakage detection system is installed, at least every 24 months.
- For equipment that contains fluorinated greenhouse gases in quantities of 50 tonnes of CO2 equivalent or more, but of less than 500 tonnes of CO2 equipment, at least every six months, or where a leakage detection system is installed, at least every 12 months.
- For equipment that contains fluorinated greenhouse gases in quantities of 500 tonnes of CO2 equivalent or more, at least every three months, or where a leakage detection system is installed, at least every six months.
- Non-hermetically sealed equipment charged with fluorinated greenhouse gases shall only be sold to the end user where evidence is provided that the installation is to be carried out by an undertaking certified person.
- Only certificated person is allowed to do installation, operation and maintenance.

## 7.4 After-sales Service and Warranty

### 7.4.1 Warranty period

- This product contains the warranty card that was completed by the agent during installation. The customer must check the completed warranty card and keep it properly.
- If you need to repair the air conditioner during the warranty period, please contact the agent and provide the warranty card.

### 7.4.2 Recommended maintenance and inspection

As the use of the unit for many years will eventually lead to a dust layer, the performance of the unit will degenerate to a certain extent. As professional skills are needed to dismantle and clean the unit, and for the optimal maintenance effects of this unit, please contact your agent for more details.

When you request the agent for assistance, please remember to state:

- Complete model name of the air conditioner.
- Date of installation.
- Details on the fault symptoms or errors, and any defects.



### Warning

- Do not attempt to modify, dismantle, remove, reinstall or repair this unit, as the improper dismantling or installation may result in electric shock or fire. Please contact the agent.
- If the refrigerant accidentally leaks, make sure that there is no fire around the unit. The refrigerant itself is completely safe, non-toxic and non-flammable, but it will produce toxic gases when it accidentally leaks and comes in contact with flammable substances generated by existing heaters, and burning devices in the room. You must get a qualified maintenance personnel to verify that the point of leakage has been repaired or rectified before you restore the operations of the unit.

### 7.4.3 Shorter maintenance and replacement cycle

In the following situations, the "maintenance cycle" and "replacement cycle" may be shortened.

The unit is used in the following situations:

- Temperature and humidity fluctuations are outside the normal ranges.
- Large power fluctuations (voltage, frequency, waveform distortion etc.) (must not use the unit if the power fluctuations exceed the allowed range).
- Frequent collisions and vibrations.
- The air may contain dust, salt, harmful gas or oil such as sulphite and hydrogen sulphide.
- Frequent on and off of unit or operating time is too long (in places where the air conditioning is on for 24 hours a day).

**GD Midea Heating &Ventilating  
Equipment Co.,Ltd.**

Penglai Industry Road,Beijiao, Shunde, Foshan,  
Guangdong,528311,P.R.China

16126000A20860 V1.0

此页不做菲林，只做说明  
材料：双胶纸100克  
尺寸：大A4纸  
颜色：黑白印刷