

Engineering Data

Arc Duct VRF IDU

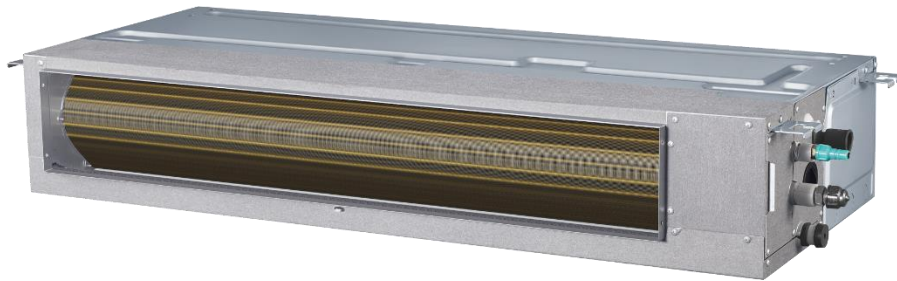

MIH15T3N18

MIH56T3N18

MIH22T3N18

MIH71T3N18

MIH28T3N18

MIH80T3N18

MIH36T3N18

MIH90T3N18

MIH45T3N18

MIH112T3N18

Arc Duct

1 Specifications	4
2 Dimensions.....	7
3 Unit Placement.....	9
4 Piping Diagram	10
5 Wiring Diagram	11
6 Capacity Tables.....	12
7 Electrical Characteristics	14
8 Sound Levels	15
9 Fan Performance	18

1 Specifications

Table 1.1: MIH15(22,28)T3N18 specifications

Model			MIH15T3N18	MIH22T3N18	MIH28T3N18
Power supply			1-phase, 220-240V, 50Hz		
Cooling ¹	Capacity	kW	1.5	2.2	2.8
		kBtu/h	5.1	7.5	9.6
	Power input	W	21	22	28
Heating ²	Capacity	kW	1.8	2.5	3.2
		kBtu/h	6.1	8.5	10.9
	Power input	W	21	22	28
Fan motor type			DC		
Indoor coil	Number of rows ³		2&3	2&3	2&3
	Tube pitch ³	mm	14&18		
	Fin spacing and type	mm	1.33 Hydrophilic aluminum		
	Tube OD and type	mm	Φ5 Inner-groove		
	Dimensions (L×H×W)	mm	380×170×95		
	Number of circuits			4	4
Air flow rate ⁴		m ³ /h	340/335/329/320/307 /298/290	370/347/339/322/314 /306/295	460/431/413/380/351 /323/300
External static pressure ⁵		Pa	10 (10-50)		
Sound pressure level ⁶		dB(A)	27/26/25.5/24.5/23.5 /22.5/22	28/27.5/26.5/25.5/24.5 /23.5/22	30/29.5/28.5/27.5/26 /24.5/22
Sound power level ⁶		dB(A)	43.5/43/42.5/42/41.5/41 /40	46/45/44/43/42/41/40	50.5/49/47/45.5/43.5 /42/40
Unit	Net dimensions ⁷ (W×H×D)	mm	550×199×450		
	Packed dimensions (W×H×D)	mm	715×255×525		
	Net/Gross weight	kg	11.5/13.5		
Refrigerant type			R410A/R32		
Throttle type			Electronic expansion valve		
Design pressure (H/L)		MPa	4.4/2.6		
Pipe connections	Liquid/Gas pipe	mm	Φ6.35/Φ12.7		
	Drain pipe	mm	OD Φ25		

Notes:

- Indoor temperature 27°C DB, 19°C WB; outdoor temperature 35°C DB; equivalent refrigerant piping length 7.5m with zero level difference.
- Indoor temperature 20°C DB; outdoor temperature 7°C DB, 6°C WB; equivalent refrigerant piping length 7.5m with zero level difference.
- Arc Duct adopts a brand-new special-shaped heat exchanger with different number of rows and different Tube pitch at different positions.
- Fan motor speed and air flow rate are from the highest speed to the lowest speed, total 7 rates for each model.
- Stable operation external static pressure range. (Note: setting external static pressure outside the unit's optimal static pressure range may lead to higher noise levels and lower airflow rate. For the optimal external static pressure range refer to the unit's installation manual.)
- Sound pressure level is from highest level to lowest level, total 7 levels for each model. Sound pressure level is measured 1.5m below the unit in an anechoic chamber.
- The dimension is only the body size, excluding the size of the installation lug, connecting copper pipe, etc. For detailed dimensions, please refer to the installation manual.
- All specifications are measured at standard external static pressure.
- G1 air filter is standard for Arc Duct.

Table 1.2: MIH36(45,56,71)T3N18 specifications

Model			MIH36T3N18	MIH45T3N18	MIH56T3N18	MIH71T3N18
Power supply			1-phase, 220-240V, 50Hz			
Cooling ¹	Capacity	kW	3.6	4.5	5.6	7.1
		kBtu/h	12.3	15.4	19.1	24.2
	Power input	W	31	43	58	65
Heating ²	Capacity	kW	4	5	6.3	8
		kBtu/h	13.7	17.1	21.5	27.3
	Power input	W	31	43	58	65
Fan motor type			DC			
Indoor coil	Number of rows ³		2&3	2&3	2&3	2&3
	Tube pitch ³	mm	14&18			
	Fin spacing and type	mm	1.33 Hydrophilic aluminum			
	Tube OD and type	mm	Φ5 Inner-groove			
	Dimensions (L×H×W)	mm	530×170×95	730×170×95		930×170×95
	Number of circuits		4	6	6	8
Air flow rate ⁴	m ³ /h	605/557/508/453 /414/365/320	800/770/701/629 /557/506/435	900/800/761/682 /603/549/470	1145/1033/957/ 860/763/671/580	
External static pressure ⁵	Pa	10 (10-50)				
Sound pressure level ⁶	dB(A)	30/29.5/28.5/27.5 26.5/25.5/25	33/32.5/32/30.5/ 29/27.5/26	36/34.5/33.5/32.5 /31/29/27	37/35/34/32.5/31 /30/29	
Sound power level	dB(A)	50.5/49.5/48/47 /45.5/44.5/43	52/50.5/49/47.5 /46/44.5/43	56/54/52/50/48 /46/44	57/55.5/54/52/ 50.5/49/47	
Unit	Net dimensions ⁷ (W×H×D)	mm	700×199×450	900×199×450		1100×199×450
	Packed dimensions (W×H×D)	mm	865×255×525	1065×255×525		1300×255×525
	Net/Gross weight	kg	13.0/15.5	16.5/19.5		20/23.5
Refrigerant type			R410A/R32			
Throttle type			Electronic expansion valve			
Design pressure (H/L)		MPa	4.4/2.6			
Pipe connections	Liquid/Gas pipe	mm	Φ6.35/Φ12.7			Φ9.52/Φ15.9
	Drain pipe	mm	OD Φ25			

Notes:

- Indoor temperature 27°C DB, 19°C WB; outdoor temperature 35°C DB; equivalent refrigerant piping length 7.5m with zero level difference.
- Indoor temperature 20°C DB; outdoor temperature 7°C DB, 6°C WB; equivalent refrigerant piping length 7.5m with zero level difference.
- Arc Duct adopts a brand-new special-shaped heat exchanger with different number of rows and different Tube pitch at different positions.
- Fan motor speed and air flow rate are from the highest speed to the lowest speed, total 7 rates for each model.
- Stable operation external static pressure range. (Note: setting external static pressure outside the unit's optimal static pressure range may lead to higher noise levels and lower airflow rate. For the optimal external static pressure range refer to the unit's installation manual.)
- Sound pressure level is from highest level to lowest level, total 7 levels for each model. Sound pressure level is measured 1.5m below the unit in an anechoic chamber.
- The dimension is only the body size, excluding the size of the installation lug, connecting copper pipe, etc. For detailed dimensions, please refer to the installation manual.
- All specifications are measured at standard external static pressure.
- G1 air filter is standard for Arc Duct.

Table 1.3: MIH80(90,112)T3N18 specifications

Model			MIH80T3N18	MIH90T3N18	MIH112T3N18
Power supply			1-phase, 220-240V, 50Hz		
Cooling ¹	Capacity	kW	8	9	11.2
		kBtu/h	27.3	30.7	38.2
	Power input	W	108	108	128
Heating ²	Capacity	kW	9	10	12.5
		kBtu/h	30.7	34.1	42.7
	Power input	W	108	108	128
Fan motor type			DC		
Indoor coil	Number of rows ³		2&3	2&3	2&3
	Tube pitch ³	mm	14&18		
	Fin spacing and type	mm	1.33 Hydrophilic aluminum		
	Tube OD and type	mm	Φ5 Inner-groove		
	Dimensions (L×H×W)	mm	1405×170×95		
	Number of circuits		12		
Air flow rate ⁴ (20Pa)		m ³ /h	1400/1327/1249/1175 /1095/1026/960	1400/1327/1249/1175 /1095/1026/960	1620/1522/1433/1343 /1254/1170/1080
External static pressure ⁵		Pa	20(10-80)		
Sound pressure level ⁶ (20Pa)		dB(A)	36.5/35.5/34/33/32/31.5 /30.5	36.5/35.5/34/33/32/31.5 /30.5	39.5/38/36.5/35/34/32.5 /31.5
Sound power level(20Pa)		dB(A)	57/56/54.5/53.5/52/51 /49.5	57/56/54.5/53.5/52/51 /49.5	60.5/59/57.5/55.5/54 /52.5/50.5
Unit	Net dimensions ⁷ (W×H×D)		1600×199×450		
	Packed dimensions (W×H×D)		1780×250×525		
	Net/Gross weight		28/32.5		
Refrigerant type			R410A/R32		
Throttle type			Electronic expansion valve		
Design pressure (H/L)		MPa	4.4/2.6		
Pipe connections	Liquid/Gas pipe		Φ9.52/Φ15.9		
	Drain pipe		OD Φ25		

Notes:

- Indoor temperature 27°C DB, 19°C WB; outdoor temperature 35°C DB; equivalent refrigerant piping length 7.5m with zero level difference.
- Indoor temperature 20°C DB; outdoor temperature 7°C DB, 6°C WB; equivalent refrigerant piping length 7.5m with zero level difference.
- Arc Duct adopts a brand-new special-shaped heat exchanger with different number of rows and different Tube pitch at different positions.
- Fan motor speed and air flow rate are from the highest speed to the lowest speed, total 7 rates for each model.
- Stable operation external static pressure range. (Note: setting external static pressure outside the unit's optimal static pressure range may lead to higher noise levels and lower airflow rate. For the optimal external static pressure range refer to the unit's installation manual.)
- Sound pressure level is from highest level to lowest level, total 7 levels for each model. Sound pressure level is measured 1.5m below the unit in an anechoic chamber.
- The dimension is only the body size, excluding the size of the installation lug, connecting copper pipe, etc. For detailed dimensions, please refer to the installation manual.
- All specifications are measured at standard external static pressure.
- G1 air filter is standard for Arc Duct.

2 Dimensions

2.1 Unit Dimensions

Figure 2.1: External dimension, air outlet size, and size of fresh air outlet: (unit: mm)

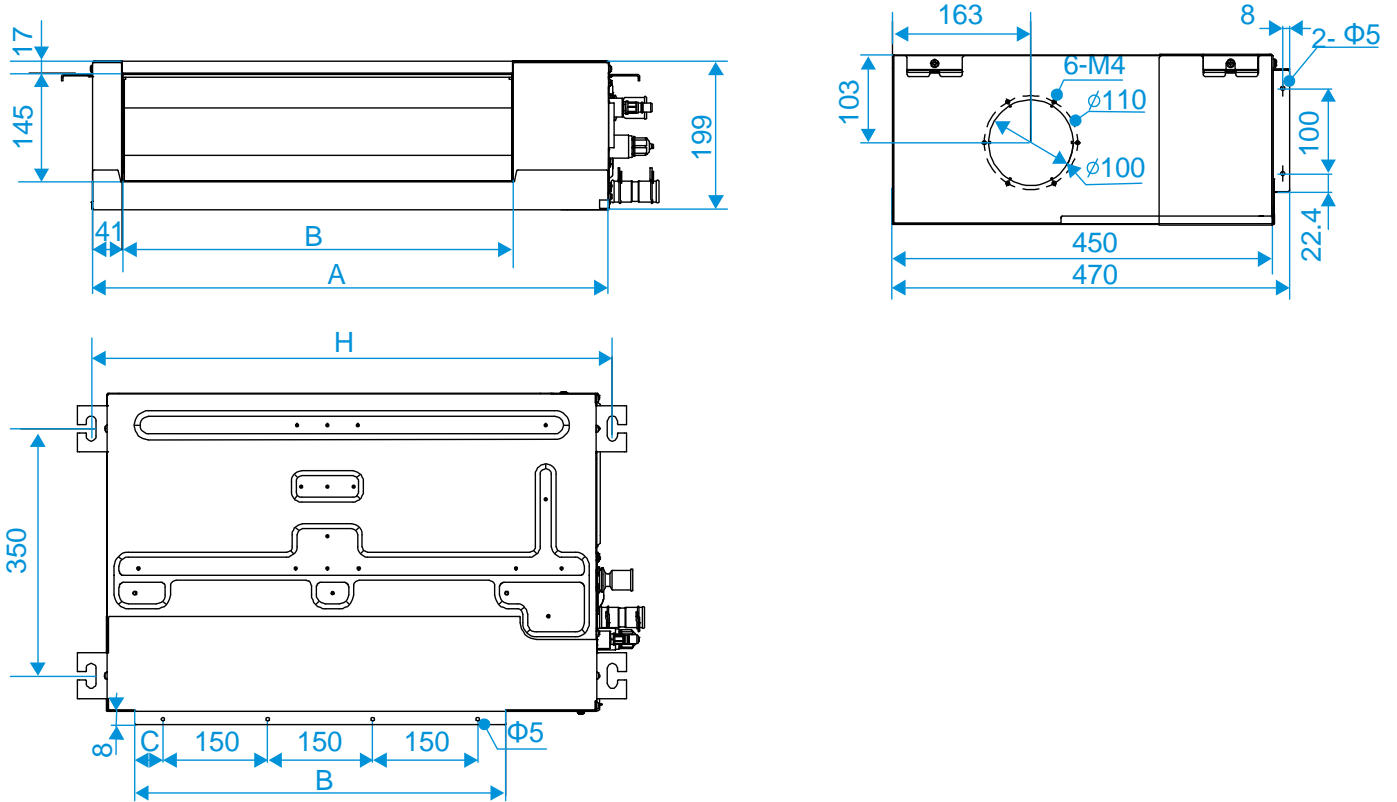

Figure 2.2: Size of return air inlet (rear return air mode): (unit: mm)

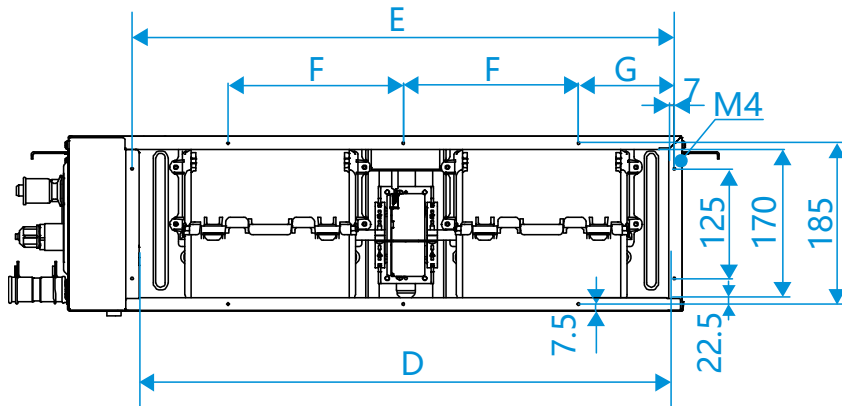

Table 2.1: Letter-Size Correspondence Table: (unit: mm)

Capacity (kW)	A	B	C	D	E	F	G	H	I	J
kW≤2.8	550	380	40	455	469	250	109.5	595	7/16-20 UNF	3/4-16 UNF
2.8<kW≤3.6	700	530	40	605	619	200	109.5	745		
3.6<kW≤5.6	900	730	65	805	819	200	109.5	945		
5.6<kW≤7.1	1100	930	15	1005	1019	200	109.5	1145	5/8-18 UNF	7/8-14 UNF
7.1<kW≤11.2	1600	1400	25	1505	1519	200	159.5	1645		

V8 VRF Indoor Units



Figure 2.3: Size of return air inlet (bottom return air mode) and distance between lifting lugs:(unit: mm)

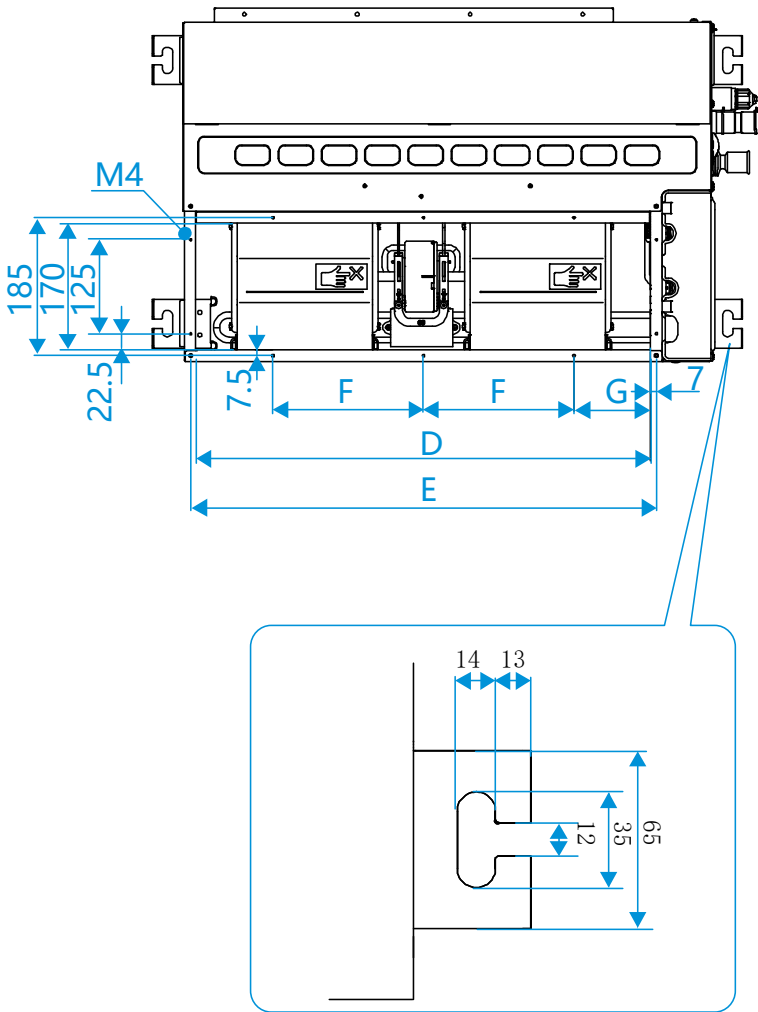

Notes:

1. meaning of letters refer to Table 2.1

Figure 2.4: Piping and water pipe size:(unit: mm)

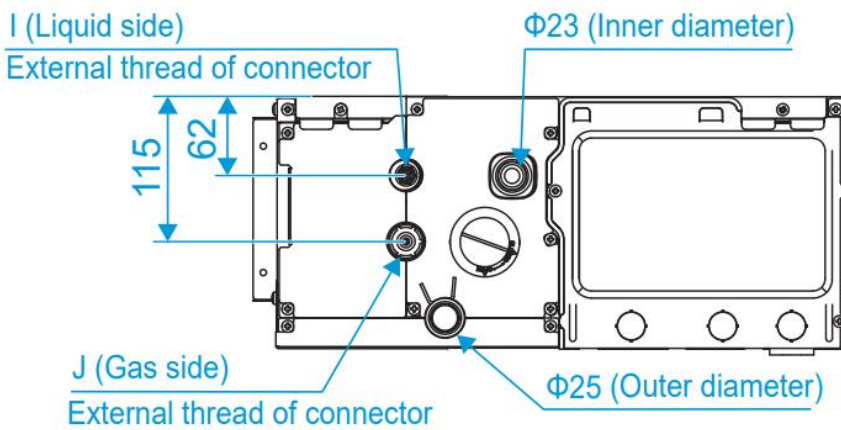

Notes:

1. meaning of letters refer to Table 2.1

3 Unit Placement

3.1 Placement Considerations

Unit placement should take account of the following considerations:

- Units should not be installed in the following locations:
 - A place filled with mineral oil, fumes or mist, like a kitchen.
 - A place where there are corrosive gases, such as acid or alkaline gases..
 - A place exposed to combustible gases and using volatile combustible gases such as diluent or gasoline.
 - A place where there is equipment emitting electromagnetic radiation.
 - A place where there is a high salt content in the air like a coast.
 - Do not use the air conditioner in an environment where an explosion may occur.
 - Places like in vehicles or cabin rooms.
 - Factories with major voltage fluctuations in the power supplies.
 - Other special environmental conditions.
- Units should be installed in positions where:
 - Ensure that the airflow in and out of the IDU is reasonably organized to form an air circulation in the room.
 - Ensure IDU maintenance space.
 - The nearer the drainage pipe and copper pipe are to the ODU, the lower the pipe cost is.
 - Prevent the air conditioner from blowing directly to the human body.
 - The closer the wiring to the power cabinet, the lower the wiring cost is.
 - Keep the air-conditioning return air away from the setting sun of the room.
 - Be careful not to interfere with the light tank, fire pipe, gas pipe and other facilities.
 - The IDU should not be lifted in the places like load-bearing beam and columns that affect the structural safety of the house.
 - The wired controller and the IDU should be in the same installation space; otherwise, the sampling point setting of the wired controller need to be changed.

3.2 Space Requirements

Figure 3.1: Arc Duct space requirements (unit: mm)

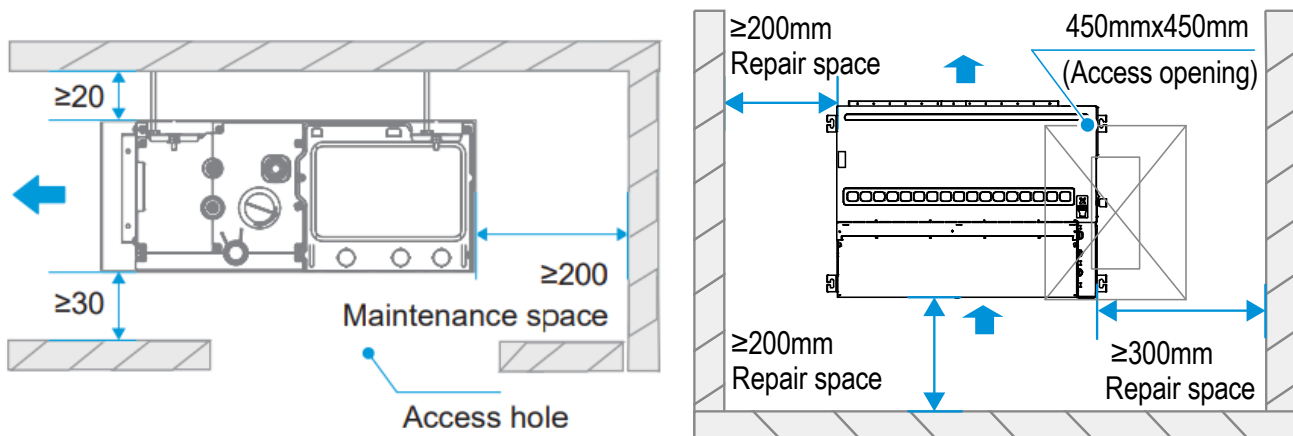

Notes:

1. The centerline of the maintenance hole should be in the same position as the centerline of the indoor unit.

4 Piping Diagram

Figure 4.1: Arc Duct piping diagram

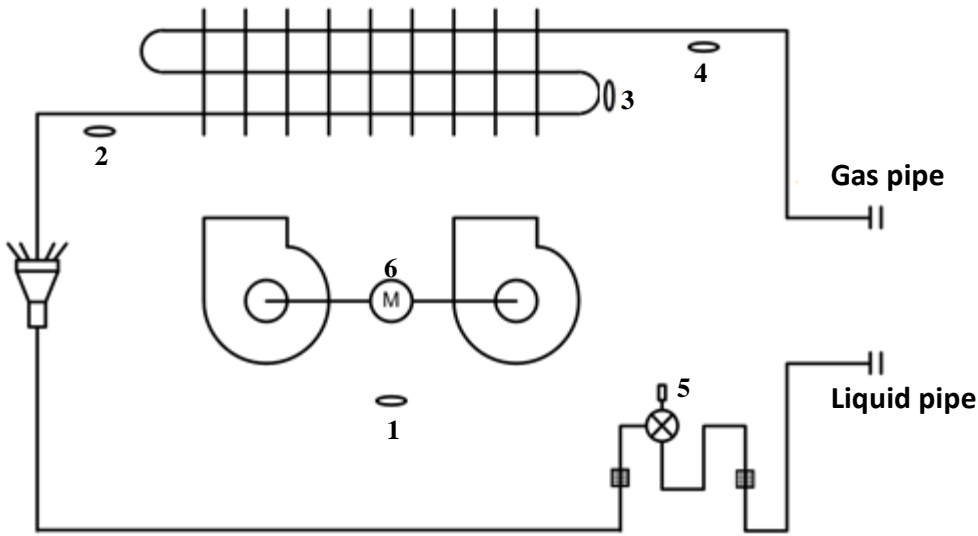

Legend	Code	Description
1	T1	Inlet Air Temp. Sensor
2	T2A	Liquid Pipe Temp. Sensor
3	T2	Middle Pipe Temp. Sensor
4	T2B	Gas Pipe Temp. Sensor
5	EEV	Electronic Expansion Valve
6	FAN	DC Fan motor

5 Wiring Diagram

Figure 5.1: Arc Duct wiring diagram

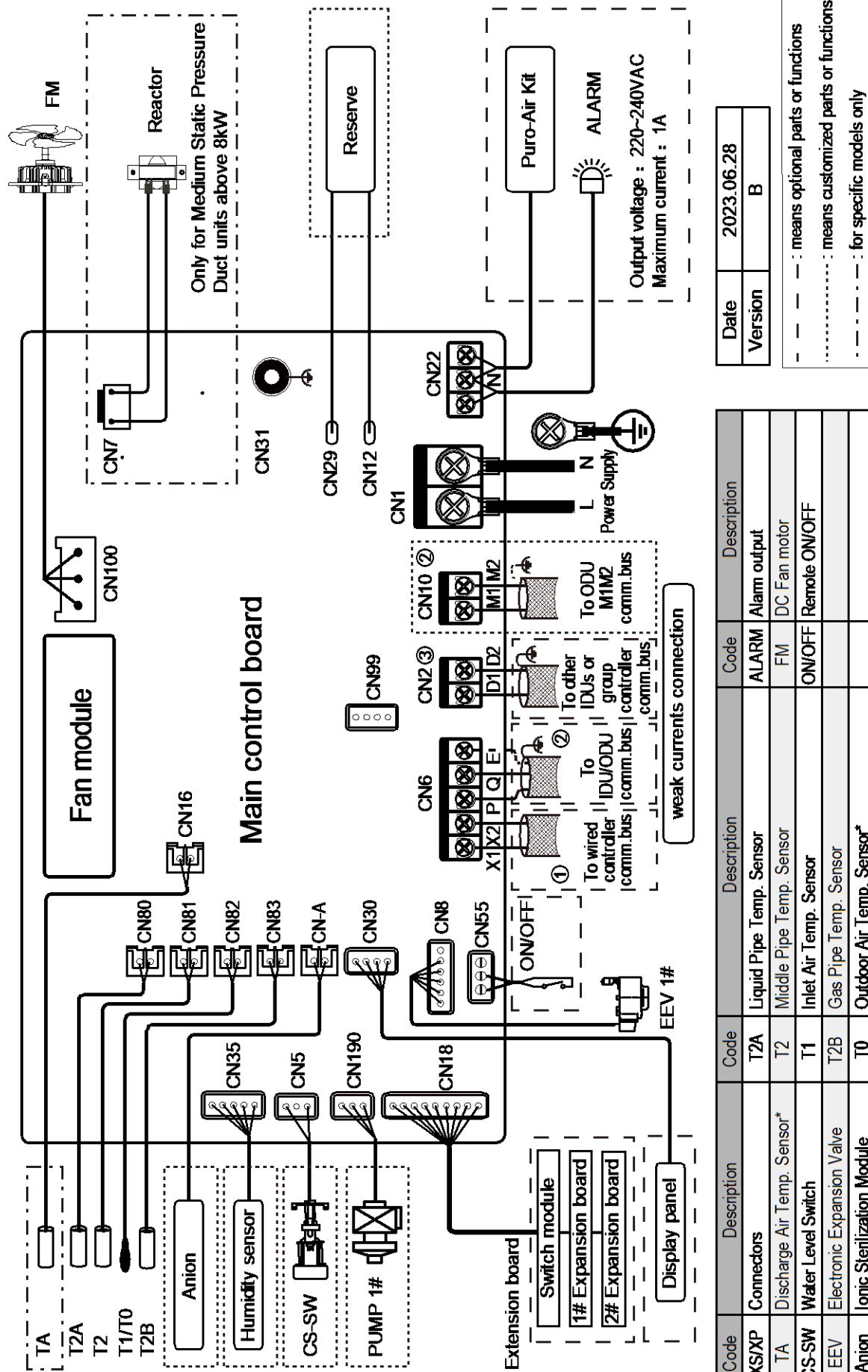

Date	2023.06.28
Version	B

- - - : means optional parts or functions
- : means customized parts or functions
- . - . - : for specific models only

* Indicates that this sensor is only available for Fresh Air Processing Unit

Notes for installers and service engineers

Caution

- All installation, servicing and maintenance must be carried out by competent and suitably qualified, certified and accredited professionals and in accordance with all applicable legislation.
- Units should be grounded in accordance with all applicable legislation. Metal and other conductive components should be insulated in accordance with all applicable legislation.
- Power supply wiring should be securely fastened at the power supply terminals – loose power supply wiring would represent a fire risk.
- After installation, servicing or maintenance, the electric control box cover should be closed. Failing to close the electric control box cover risks fire or electric shock.
- The dotted lines indicate the field wiring or optional function.
- PQ and M1M2 communication ports both are used for indoor and outdoor communication, and only one of them can be used at a time. Meanwhile, be sure to connect the same communication ports (PQ to PQ; M1M2 to M1M2) in case of damage of the main control board.
- D1D2 communication ports are used for group control communication. When connecting the group controller, the D1D2 port of the indoor units that are to be group controlled must be connected in daisy chain, and the group controller must be connected to the X1X2 port of one of the indoor units in the group control, and set to group control mode. In addition, D1D2 communication ports can also be connected to the central controller.

6 Capacity Tables

6.1 Cooling Capacity Table

Table 6.1: Arc Duct cooling capacity

Model	Indoor air temperature (°C WB/DB)													
	14/20		16/23		18/26		19/27		20/28		22/30		24/32	
	TC	SC	TC	SC	TC	SC	TC	SC	TC	SC	TC	SC	TC	SC
MIH15T3N18	1.4	1.3	1.5	1.4	1.5	1.3	1.5	1.3	1.6	1.3	1.6	1.2	1.6	1.1
MIH22T3N18	2.0	1.9	2.1	1.9	2.2	1.9	2.2	1.8	2.3	1.8	2.3	1.7	2.4	1.7
MIH28T3N18	2.5	2.3	2.7	2.4	2.8	2.4	2.8	2.3	2.9	2.3	2.9	2.2	3.0	2.1
MIH36T3N18	3.2	3.0	3.4	3.1	3.6	3.1	3.6	3.0	3.7	3.0	3.8	2.8	3.9	2.7
MIH45T3N18	4.0	3.7	4.3	3.8	4.5	3.9	4.5	3.7	4.6	3.6	4.7	3.5	4.8	3.3
MIH56T3N18	5.0	4.6	5.3	4.7	5.6	4.8	5.6	4.6	5.7	4.5	5.8	4.3	6.0	4.1
MIH71T3N18	6.3	5.8	6.7	5.9	7.0	6.0	7.1	5.8	7.2	5.7	7.4	5.4	7.6	5.2
MIH80T3N18	7.1	6.3	7.6	6.5	7.9	6.6	8.0	6.5	8.1	6.3	8.3	6.0	8.5	5.8
MIH90T3N18	8.0	7.1	8.5	7.3	8.9	7.4	9.0	7.3	9.1	7.1	9.4	6.8	9.6	6.5
MIH112T3N18	9.9	8.8	10.6	9.1	11.1	9.3	11.2	9.1	11.3	8.8	11.6	8.4	11.9	8.1

Abbreviations:

TC: Total capacity (kW)

SC: Sensible capacity(kW)

Notes:

1. Shaded cells indicate rating condition.

6.2 Heating Capacity Table
Table 6.2: Arc Duct heating capacity

Model	Indoor air temperature (°C DB)					
	16	18	20	21	22	24
	SHC	SHC	SHC	SHC	SHC	SHC
MIH15T3N18	1.9	1.9	1.8	1.7	1.7	1.6
MIH22T3N18	2.7	2.7	2.5	2.4	2.4	2.2
MIH28T3N18	3.4	3.4	3.2	3.1	3.0	2.8
MIH36T3N18	4.2	4.2	4.0	3.8	3.8	3.5
MIH45T3N18	5.3	5.3	5.0	4.8	4.7	4.4
MIH56T3N18	6.7	6.6	6.3	6.1	5.9	5.5
MIH71T3N18	8.5	8.4	8.0	7.8	7.5	7.0
MIH80T3N18	9.5	9.5	9.0	8.7	8.5	7.8
MIH90T3N18	10.6	10.5	10.0	9.7	9.4	8.8
MIH112T3N18	13.3	13.1	12.5	12.1	11.8	10.9

Abbreviations:

SHC: Sensible Heat Capacity

Notes:

1. Shaded cells indicate rating condition.

7 Electrical Characteristics

Table 7.1: Arc Duct electrical characteristics

Model name	Power supply						Indoor Fan Motor	
	Hz	Volts	Min. volts	Max. volts	MCA	MFA	Rated motor output (W)	FLA
MIH15T3N18	50/60	220-240	198	264	0.88	15	20	0.70
MIH22T3N18	50/60	220-240	198	264	0.88	15	20	0.70
MIH28T3N18	50/60	220-240	198	264	0.88	15	20	0.70
MIH36T3N18	50/60	220-240	198	264	0.94	15	20	0.75
MIH45T3N18	50/60	220-240	198	264	1.10	15	30	0.85
MIH56T3N18	50/60	220-240	198	264	1.10	15	30	0.85
MIH71T3N18	50/60	220-240	198	264	1.20	15	50	0.94
MIH80T3N18	50/60	220-240	198	264	1.70	15	60	1.35
MIH90T3N18	50/60	220-240	198	264	1.70	15	60	1.35
MIH112T3N18	50/60	220-240	198	264	1.70	15	60	1.35

Abbreviations:

MCA: Minimum Circuit Amps

MFA: Maximum Fuse Amps

FLA: Full Load Amps

8 Sound Levels

8.1 Overall

Table 8.1: Arc Duct sound pressure levels¹

Model name	Sound pressure levels dB						
	SSH	SH	H	M	L	SL	SSL
MIH15T3N18	27	26	25	24	23	22.5	22
MIH22T3N18	28	27	26	25	24	23.5	22
MIH28T3N18	30	29	28	27	26	25	22
MIH36T3N18	30	29	28	27	26	25.5	25
MIH45T3N18	33	32.5	32	30	29	28	26
MIH56T3N18	36	34	33	32	31	30	27
MIH71T3N18	37	35	34	32.5	31	30	29
MIH80T3N18	36.5	35	34	33	32	31	30.5
MIH90T3N18	36.5	35	34	33	32	31	30.5
MIH112T3N18	39.5	38	36.5	35	34	32.5	31.5

Notes:

1. The sound pressure level is measured in an anechoic chamber at a distance of 1.5m below the unit, under the default static pressure setting at the factory. During on-site operation, the sound pressure level may be higher due to the influence of environmental noise.

Figure 8.2: Arc Duct sound pressure level measurement

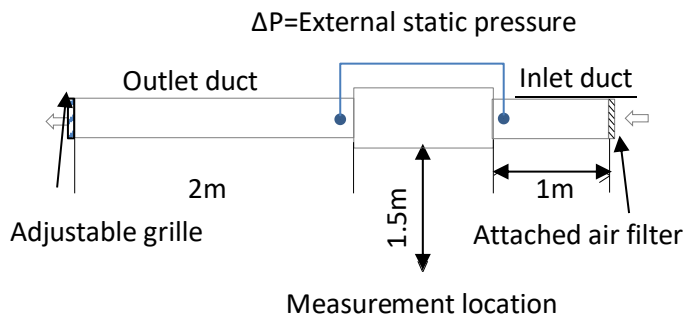

Connected to a top-discharge outdoor unit and measured in anechoic room. Adjusting the outlet grille to make the ΔP is equal to the rated static pressure, the data was recorded at 1.5m below the unit.

V8 VRF Indoor Units



8.2 Octave Band Levels

Figure 8.3: MIH15T3N18 octave band levels

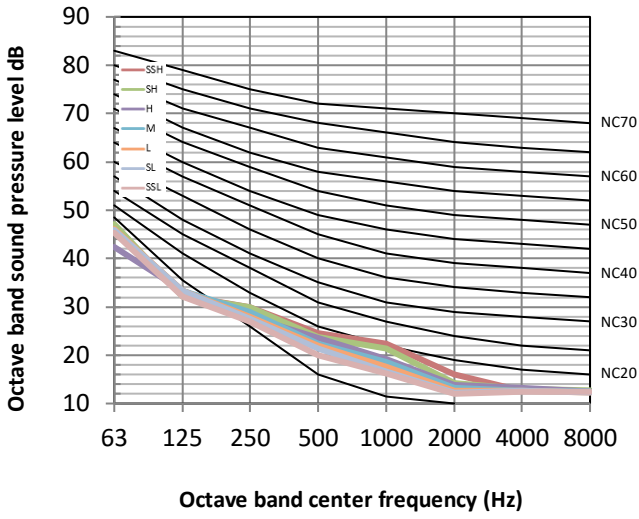

Figure 8.4: MIH22T3N18 octave band levels

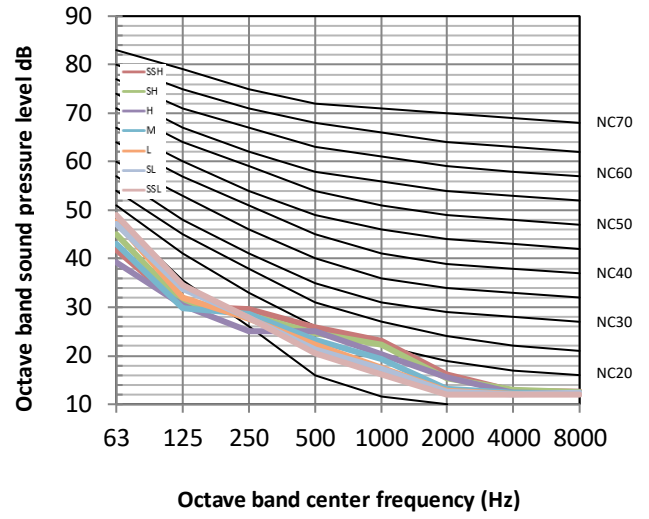

Figure 8.5: MIH28T3N18 octave band levels

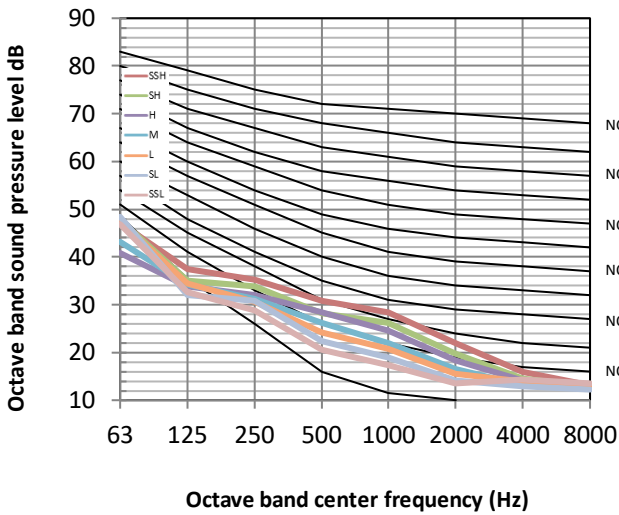

Figure 8.6: MIH36T3N18 octave band levels

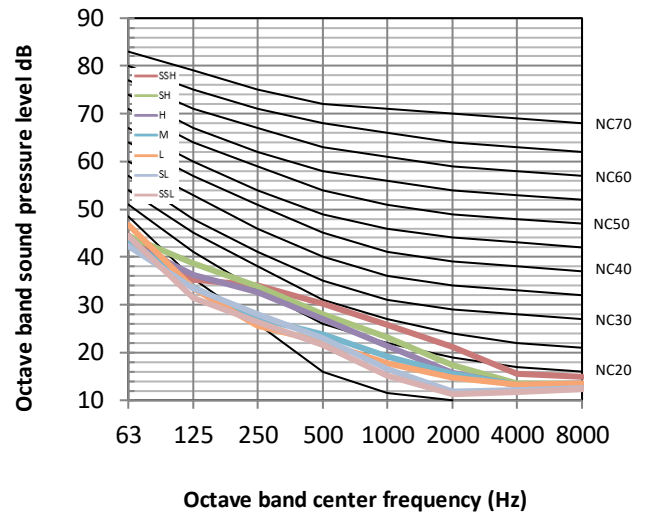

Figure 8.7: MIH45T3N18 octave band levels

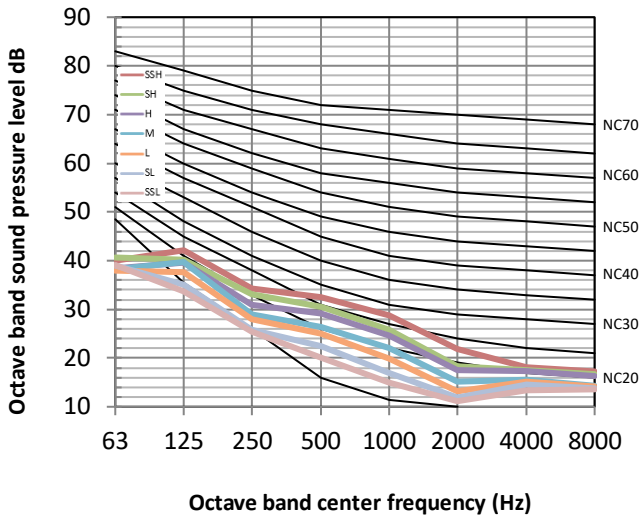

Figure 8.8: MIH56T3N18 octave band levels

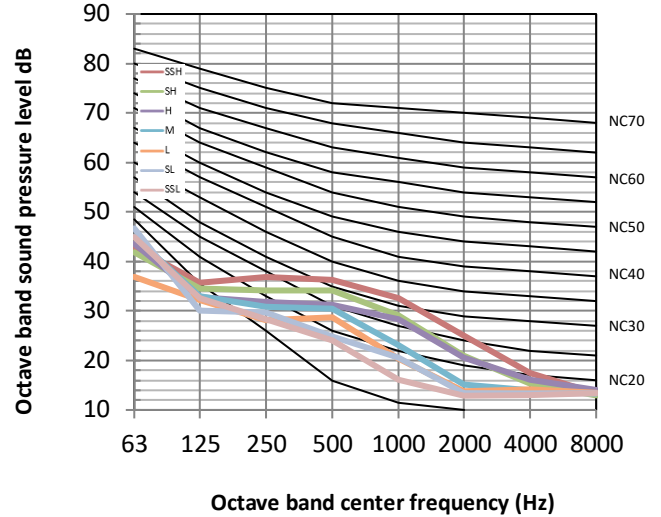

Figure 8.9: MIH71T3N18 octave band levels

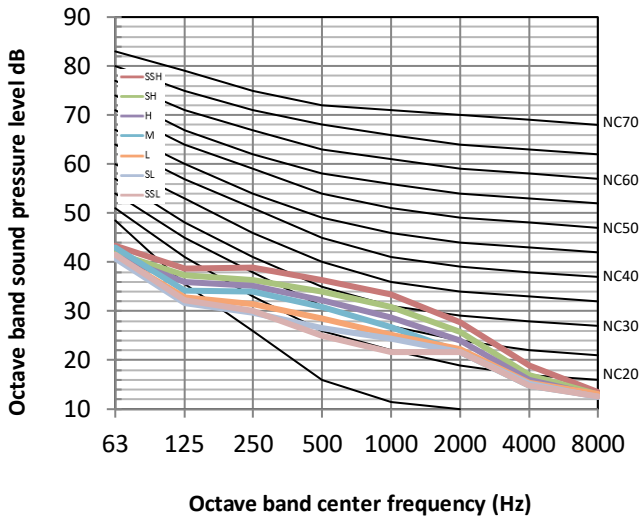

Figure 8.10: MIH80T3N18 octave band levels

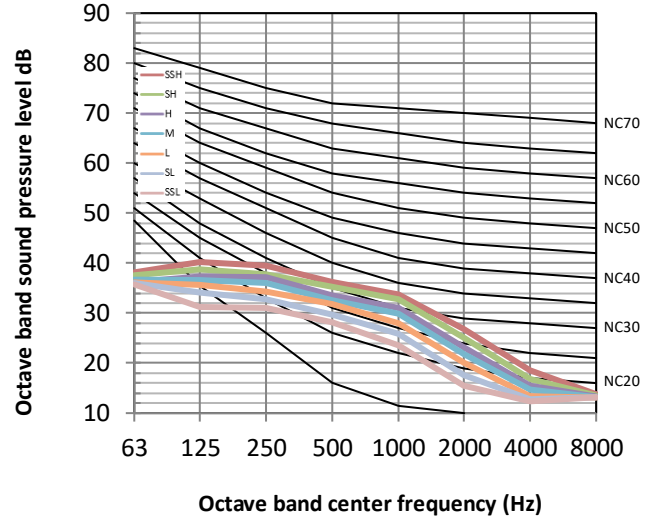

Figure 8.11: MIH90T3N18 octave band levels

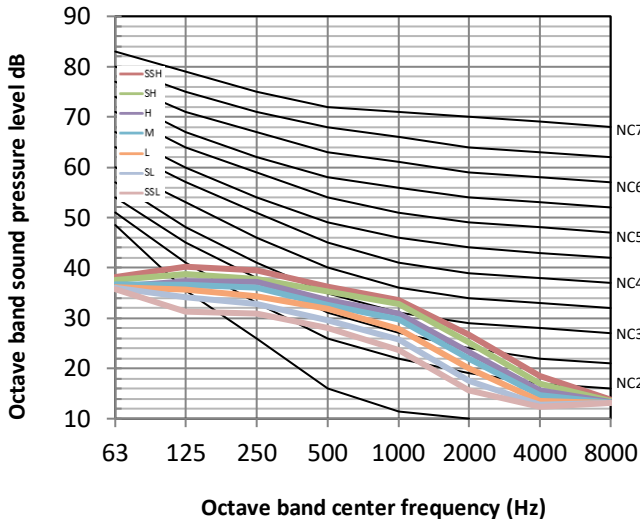
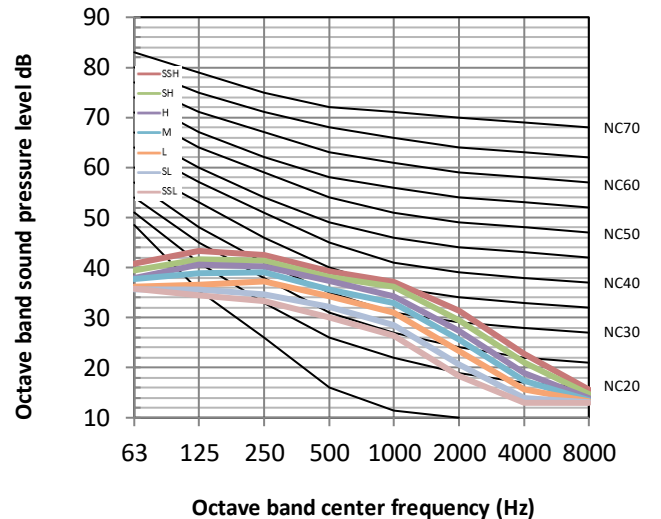

Figure 8.12: MIH112T3N18 octave band levels



9 Fan Performance

9.1 How to switch between Constant Airflow mode and Constant Speed mode

① In the main interface, press "≡" + "↵" for 3 seconds at the same time, and the main interface will display "CC". Press the "▲" and "▼" to select the indoor unit ("n00-n63" is displayed, and the last two digits are the indoor unit addresses). Press the "↵" to enter the parameter setting interface, and "n00" will be displayed.

② Press the "▲" and "▼" until "N30" is displayed on the page, and

then press the "↵" to enter the mode setting. Use the "▲" and "▼" keys to adjust to the demand mode parameter values, and press the "↵" to confirm.

③ Press the "⌚" button to return to the previous menu and exit the parameter setting. Parameter setting will also exit after 60 s of no operation

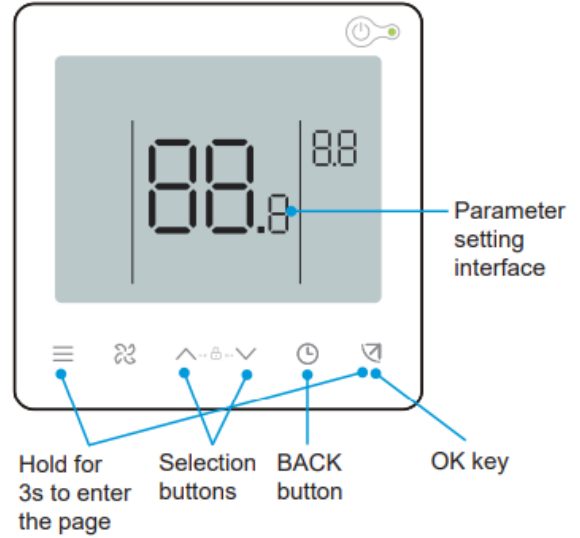

Table 9.1: Arc Duct mode setting

First level menu	Second level menu	Description	Default
n30	00	Constant Speed	-
	01	Constant Airflow	√

9.2 Constant Airflow mode

9.2.1 Fan performance diagram

Figure 9.1: MIH15T3N18

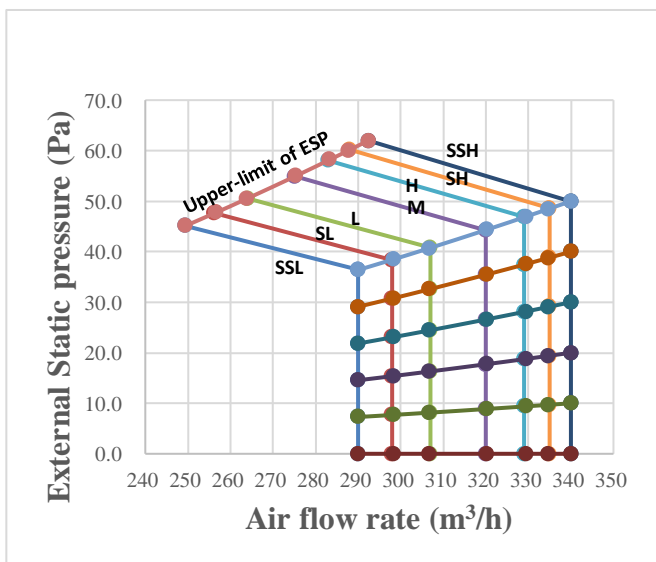

Figure 9.2: MIH22T3N18

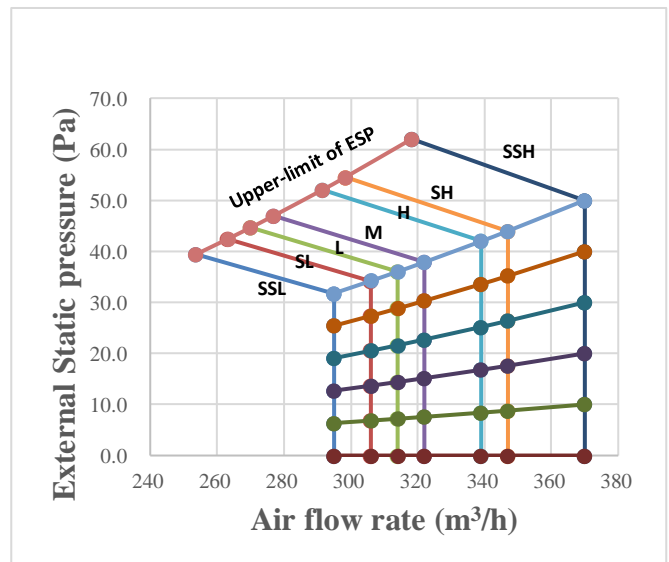

Figure 9.3: MIH28T3N18

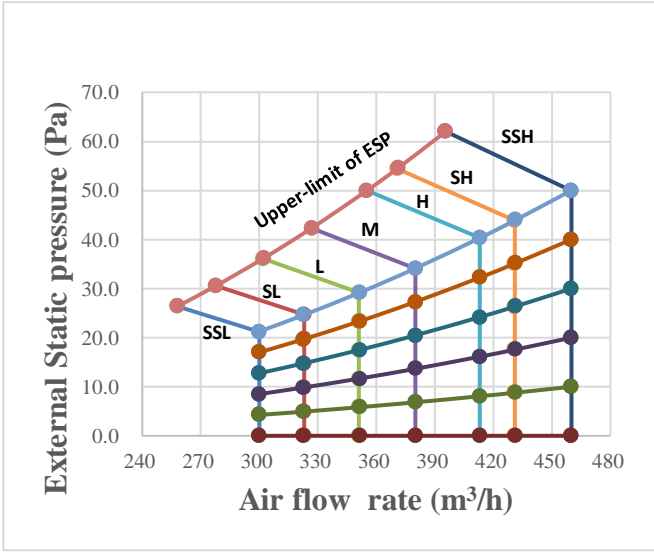

Figure 9.4: MIH36T3N18

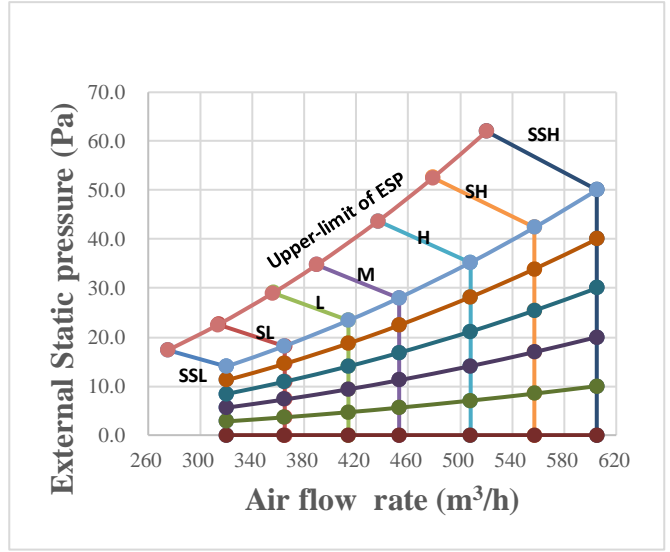

Figure 9.5: MIH45T3N18

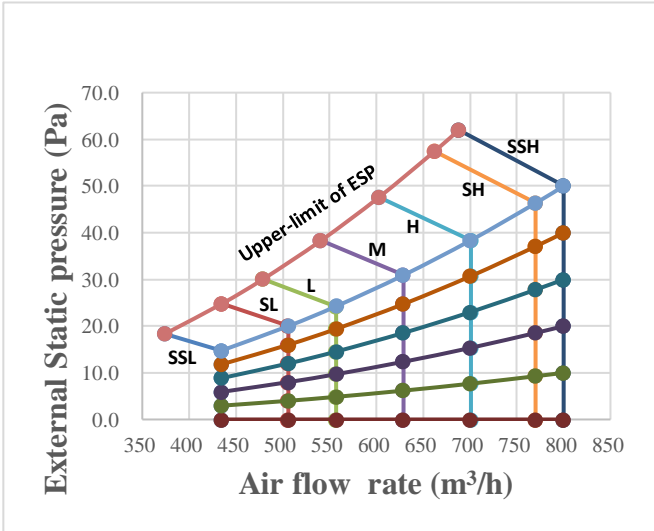

Figure 9.6: MIH56T3N18

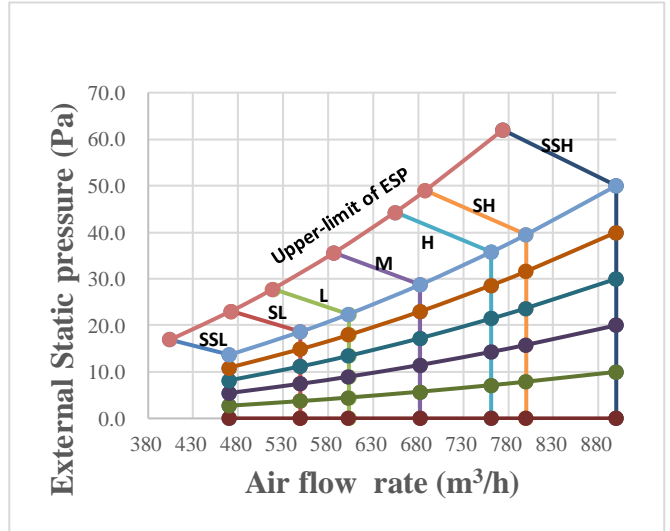

Figure 9.7: MIH71T3N18

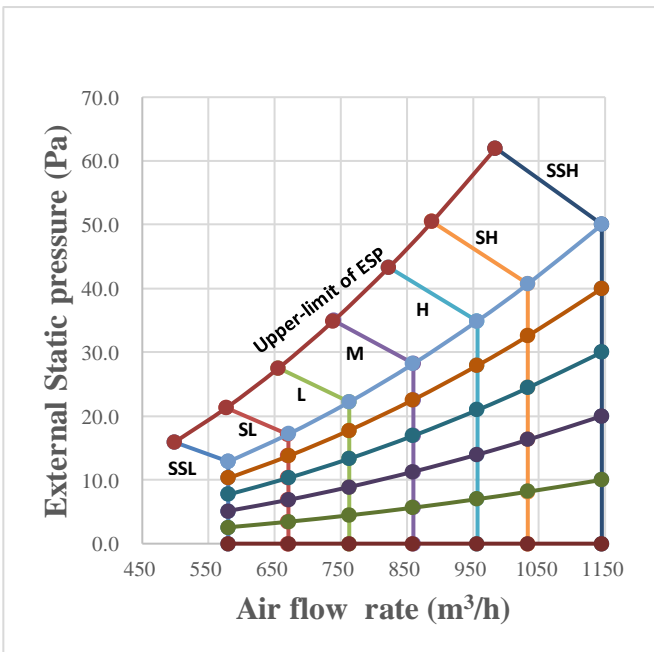

Figure 9.8: MIH80T3N18

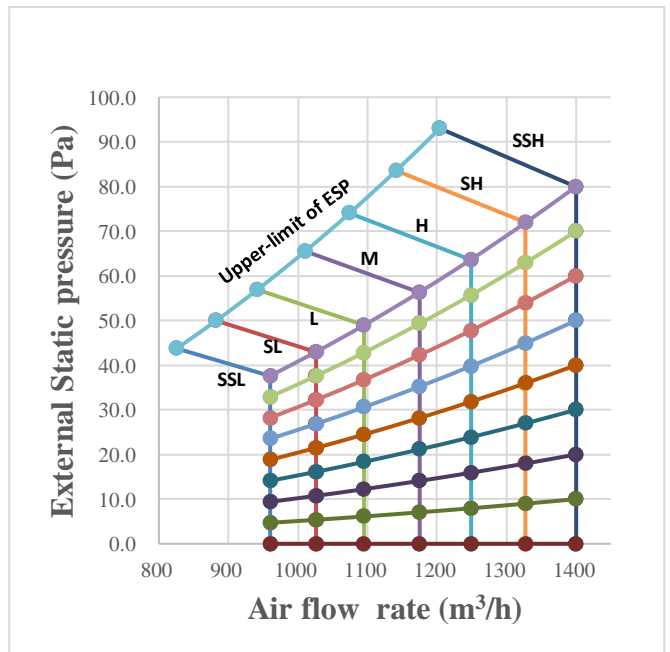

Figure 9.9: MIH90T3N18

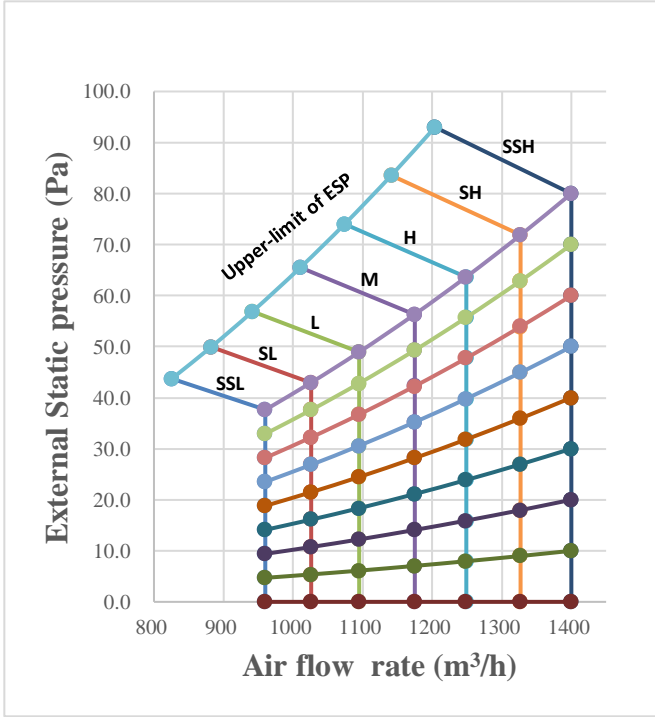
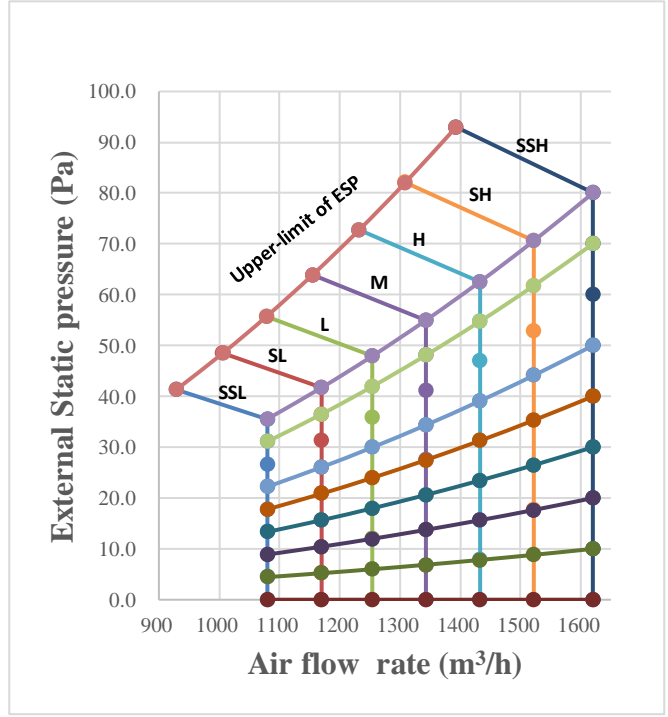

Figure 9.10: MIH112T3N18



9.2.2 How to Read the Diagram

The vertical axis is the External Static Pressure (Pa) while the horizontal axis represents the Air Flow (m³/h). The characteristic curve for the “SSH”, “SH”, “H”, “M”, “L”, “SL” and “SSL” fan speed control.

For MIH80T3N18, in “H” windshield, when the external static pressure is less than 63.7 Pa, the air flow keeps 1249 m3/h, but when the externa static pressure is greater than 63.7 Pa, the air flow begins to decline, and the allowable maximum external static pressure is 74 Pa.

9.3 Constant Speed mode

9.3.1 Set external static pressure parameters

① In the main interface, press "≡" + "↵" for 3 seconds at the same time, and the main interface will display "CC". Press the "▲" and "▼" to select the indoor unit ("n00-n63" is displayed, and the last two digits are the indoor unit addresses). Press the "↵" to enter the parameter setting interface, and "n00" will be displayed.

② When "n00" is displayed, press the "↵" to enter the static pressure setting. Use the "▲" and "▼" keys to adjust to the demand parameter values, and press the "↵" to confirm.

③ Press the "⌚" button to return to the previous menu and exit the parameter setting. Parameter setting will also exit after 60 s of no operation

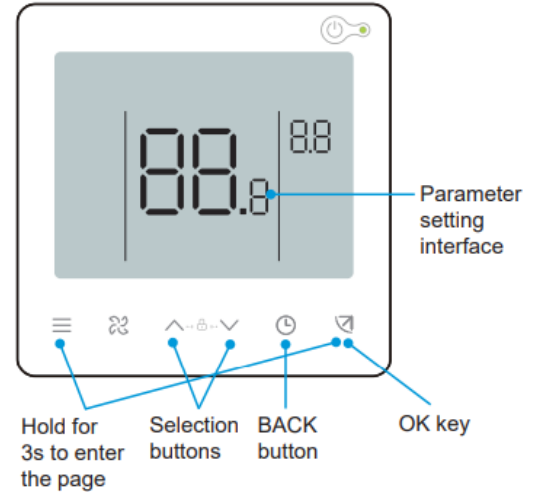

Table 9.1: External static pressure setting (1.5-7.1kW)

First level menu	Second level menu	Description	Default
N00	00/01/02/03/04/05/~ /19	Static pressure level	00

Level	00	01	02	03	04-19
Static pressure(Pa)	10	20	30	40	50

Table 9.2: External static pressure setting (8-11.2kW)

First level menu	Second level menu	Description	Default
N00	00/01/02/03/04/05/~ /19	Static pressure level	01

Level	00	01	02	03	04	05	06	07-19
Static pressure(Pa)	10	20	30	40	50	60	70	80

Notes:

- The above is only an example of 86S wired controller. If you choose other controllers, please refer to their manuals for setting.

9.3.2 Fan performance diagram

Figure 9.11: MIH15T3N18

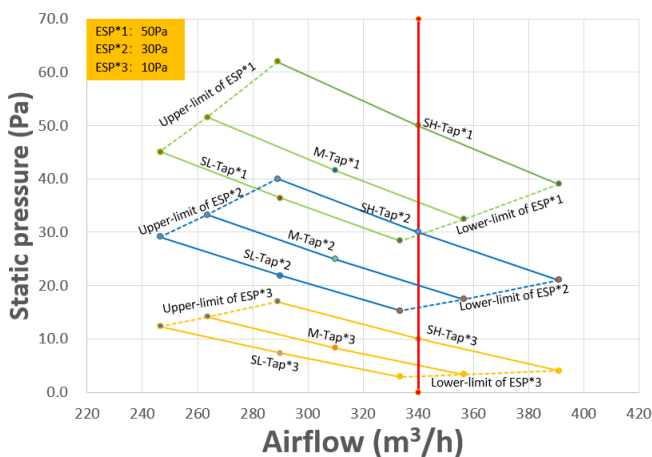

Figure 9.12: MIH22T3N18

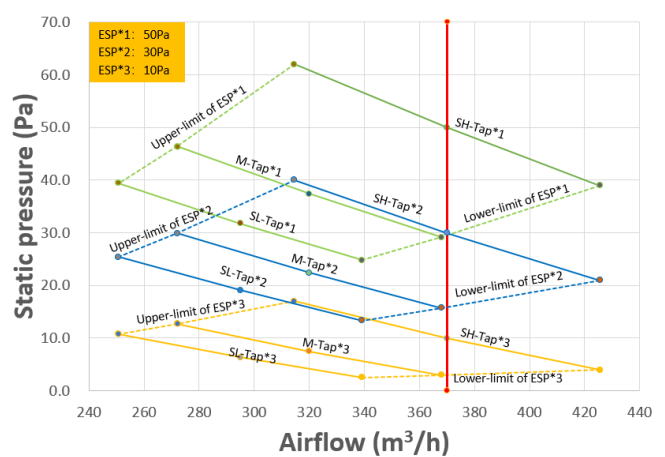

Figure 9.13: MIH28T3N18

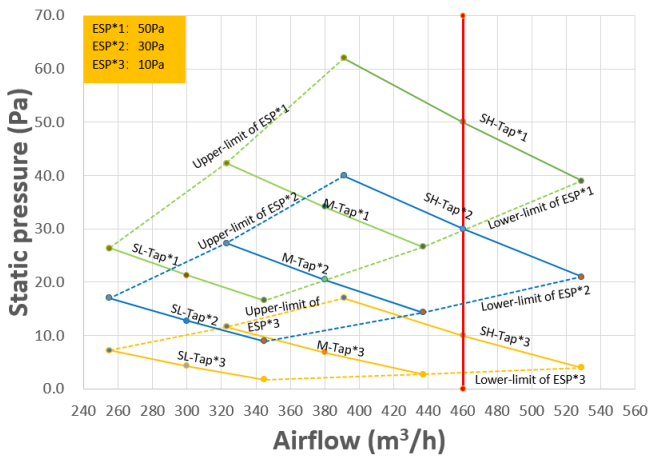

Figure 9.14: MIH36T3N18

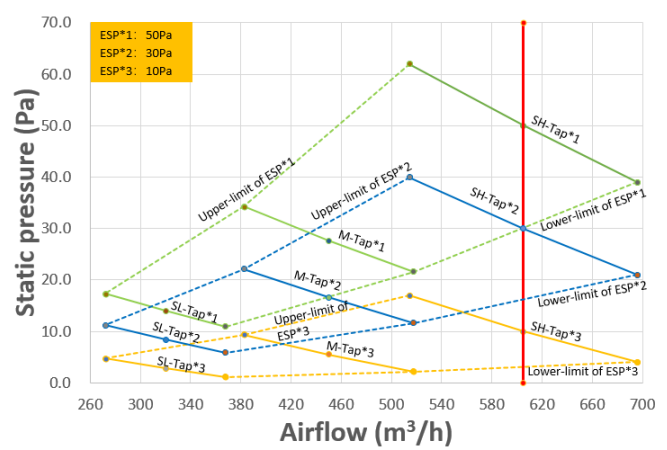

Figure 9.15: MIH45T3N18

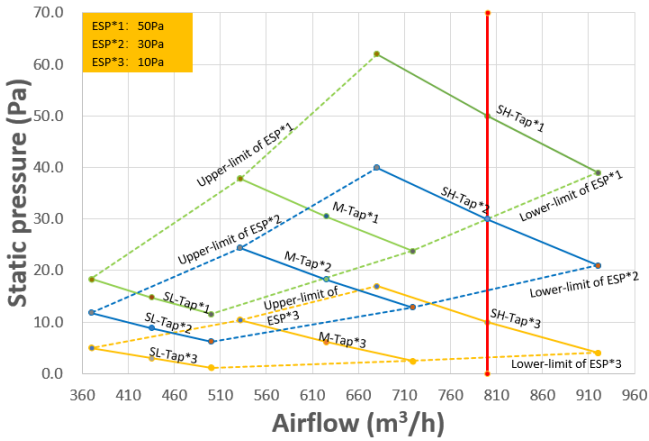

Figure 9.16: MIH56T3N18

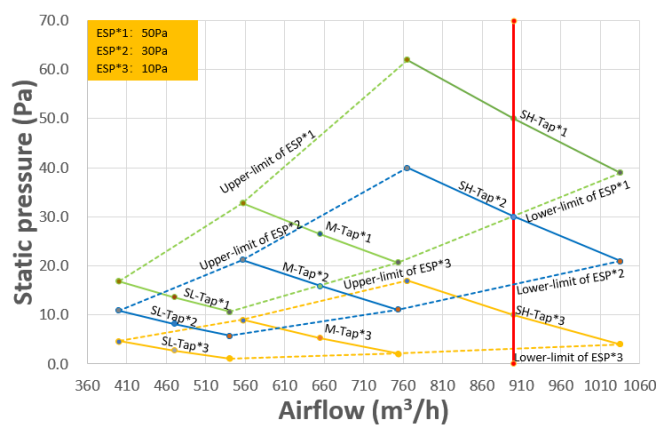

Figure 9.17: MIH71T3N18

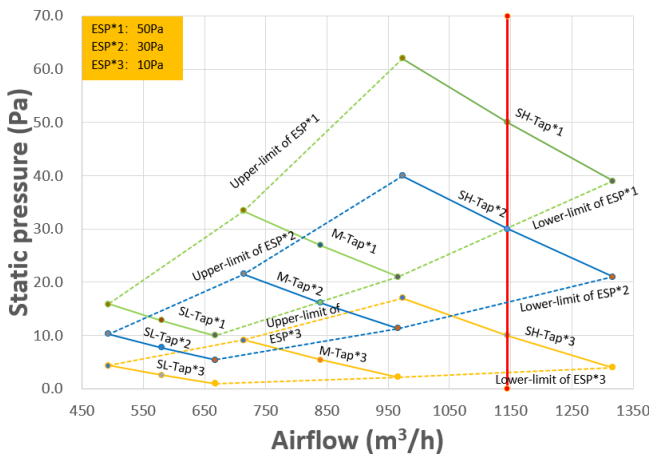

Figure 9.18: MIH80T3N18

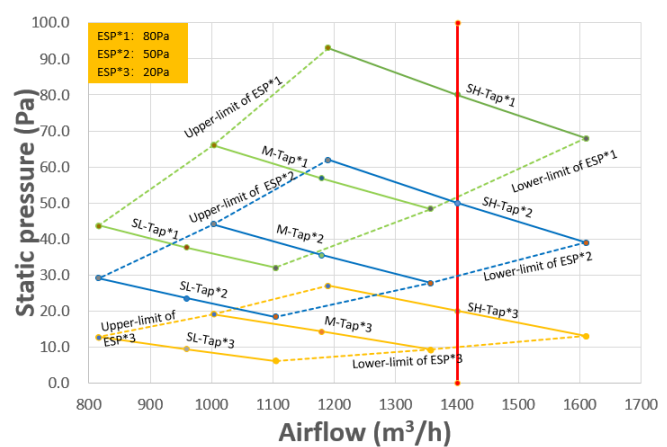

Figure 9.19: MIH90T3N18

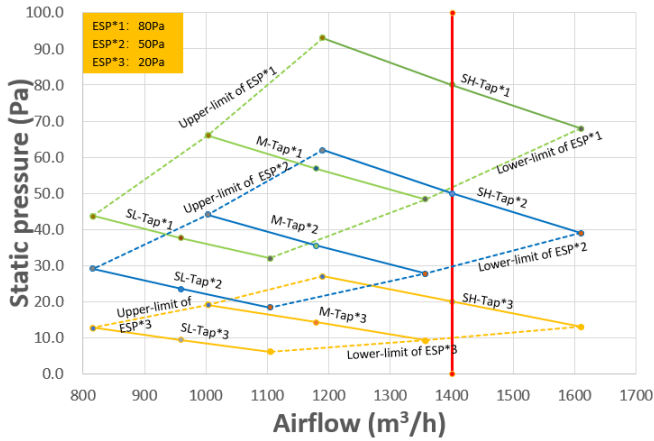
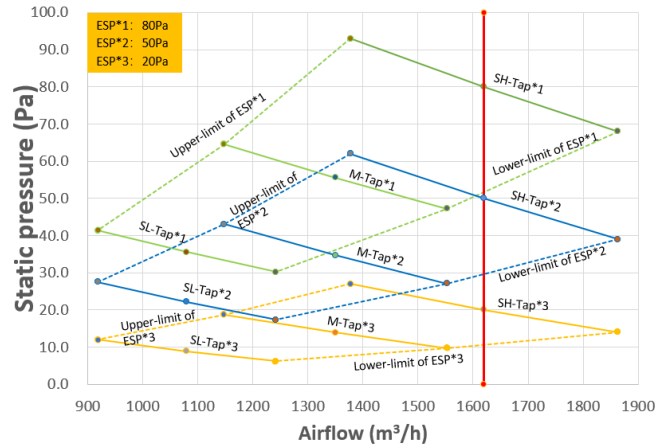

Figure 9.20: MIH112T3N18



9.3.3 How to Read the Diagram

The vertical axis is the External Static Pressure (Pa) while the horizontal axis represents the Air Flow (m³/h). The characteristic curve for the “SH”, “M” and “SL” fan speed control.

The Air Flow decreases with the increase of the external static pressure. For MIH80T3N18, in “SH” windshield and “50Pa” setting static pressure, when the external static pressure is 50Pa, the air flow is 1400 m³/h, and the allowable external static pressure range is 39 to 62.

Midea Building Technologies Division
Midea Group

Add.: Midea Headquarters Building, 6 Midea Avenue, Shunde, Foshan, Guangdong, China

Postal code: 528311

mbt.midea.com / www.midea-group.com / tsp.midea.com/

Note: Product specifications change from time to time as product improvements and developments are released and may vary from those in this document.

