



## Signaline WDM-KM Control Module Instruction Manual

### **IMPORTANT:**

**Please read this instruction leaflet thoroughly before commencing installation.**

### **Storage:**

Store the Signaline WD Water Detection Cable and Signaline WDM-KM Control Module in a cool, dry area. Storage areas should not exceed 50°C or 60% RH.

### **Signaline WD Water Detection Cable Installation Guidelines:**

- It is recommended to draw a plan of how you intend to lay the Signaline WD Water Detection Cable, this will help determine how much cable is required. Ensure the Signaline WD Water Detection Cable is laid in areas where water will naturally flow to or collect to form puddles such as at the bottom of slopes, in dips and underneath pipes. For the cable to alarm it must come in contact with water. Avoid installing the Signaline WD Water Detection Cable in areas of heavy traffic such as doorways and in areas which may result in the cable being crushed.
- Signaline WD Water Sensing Cable is supplied in pre-terminated lengths of 3.75, 7.5, 15, 30 and 100 metres. Simply plug together any number of individual lengths of Signaline WD Water Detection Cable to make up the required length. A minimum of 3.75m (12.5ft) and a maximum of 1000m (3280ft) of Signaline WD Water Detection Cable can be used with a single WDM-KM Control Module.
- If the risk area is some distance from the WDM-KM, lengths of non sensing leader cable may be used to connect the Signaline WD Water Detection Cable to the WDM-KM. Signaline LIC Lead-in Cable is also available in 10 metre (33ft) pre-terminated lengths and simply plugs into the WDM-KM. Signaline LIC Lead-in Cable may also be used in areas where non-sensing cable is required and can be connected between lengths of Signaline WD Water Detection Cable.
- Secure the Signaline WD Water Detection Cable to the floor with self adhesive tape or U clips without lifting the cable or creating an air gap underneath it. The cable should be secured at intervals of no less than 1 metre.
- Ensure the installation area is clean and free from dust and debris.
- Care should be taken to not damage the cable with sharp tools or other objects. Do not place heavy objects on the Signaline WD Water Detection Cable.
- Do not cut and re-terminate the Signaline WD Water Detection Cable. The cable connectors are terminated in the factory and **cannot be re-terminated on site.**
- Do not paint the Signaline WD Water Detection Cable.
- Do not stretch the Signaline WD Water Detection Cable tight. Some slack should be left in the cable runs.
- Do not bend the Signaline WD Water Detection Cable at right angles. The minimum bend radius is 25mm (1").
- Do not allow any conductive object to come into contact with the black conductors of the Signaline WD Water Detection Cable.

**LGM PRODUCTS LTD  
UNIT 15 RIVERSIDE INDUSTRIAL PARK  
FARNHAM  
SURREY GU9 7UG  
UNITED KINGDOM**

**TEL +44 (0) 1252 725257  
FAX +44 (0) 1252 727627  
E-mail [sales@Lgmproducts.com](mailto:sales@Lgmproducts.com)  
[www.signaline.com](http://www.signaline.com)**



## Signaline WDM-KM Control Module Instruction Manual

- Ensure adequate distance (1.8m/6ft) is left from any heating, ventilation or air conditioning downdraft which may contain moisture and condensate on the Signaline WD Water Detection Cable.
- End of Line plug is firmly attached at the end of the zone before commissioning the system
- Ensure the Signaline WD Water Detection Cable is thoroughly dried out after an alarm condition before resetting the system.
- Ensure the product is installed, commissioned and maintained by persons according to good engineering practices and installation regulations that apply in your country.

### Signaline WDM-KM Control Module Installation Guidelines

- The Signaline WDM-KM Control Module must be powered from a 24Vdc, 30mA power supply. The voltage tolerance of the module is 12 to 30 Vdc. Do **not** exceed the 30Vdc maximum rated input voltage of the Signaline WDM-KM Control Module. Do not power the WDM-KM control module from a fire alarm control panel unless it has a suitably rated auxiliary power supply.
- Do not connect the WDM-KM to a building management system or fire alarm system in a manner that will initiate fire alarm signal.
- The WDM-KM may be connected to any compatible control panel, fire alarm system, addressable module or building management system. We recommend the Signaline CB200W series of control panels that can monitor up to 8 WDM-KM control modules.

**The Signaline WDM-KM Control Module and Signaline WD Water Detection Cable are designed for use in safe areas only and must not be installed in designated hazardous areas.**

**LGM PRODUCTS LTD  
UNIT 15 RIVERSIDE INDUSTRIAL PARK  
FARNHAM  
SURREY GU9 7UG  
UNITED KINGDOM**

**TEL +44 (0) 1252 725257  
FAX +44 (0) 1252 727627  
E-mail [sales@lgmproducts.com](mailto:sales@lgmproducts.com)  
[www.signaline.com](http://www.signaline.com)**



## Signaline WDM-KM Control Module Instruction Manual

### Installation and Commissioning Procedure

- Mount the Signaline WDM-KM Control Module on a wall not less than 0.5m above floor level. If the Signaline WD Water Detection Cable is to be used to sense flooding in tunnels, car parks and similar locations, the Signaline WDM-KM Control Module must be located at least 0.5m above the maximum anticipated flood height.
- Remove the end of line plug from the Signaline WDM-KM Control Module and temporarily retain in a safe place for use later in the installation procedure.
- If the risk area is some distance from where the Signaline WDM-KM Control Module is to be located, plug a length or lengths of Signaline LIC Lead-in Cable into the Signaline WDM-KM Control Module (available in 10 metre pre-terminated lengths).
- Connect together the required Signaline WD Water Detection Cable lengths. When laying out cable ensure that male plugs point toward the Signaline WDM-KM Control Module which is fitted with a female socket.
- Re-connect the end of line plug at the far end of the Signaline WD Water Detection Cable.
- Secure the Signaline WD cable in place with suitable fixing clips or tape at not less than 1 metre intervals.
- All external connections from the Signaline WDM-KM Control Module must be made using the 6 core data cable which is integrated into the module. The module has been completely sealed for increased robustness and waterproofing. The Signaline WDM-KM Control Module is completely sealed, do not try and make any other connections inside the module. There are no user serviceable components in the Signaline WDM-KM Control Module. The sensitivity of the module is set during manufacture to provide optimum sensitivity and help prevent false alarms.
- Connect the red and black cores of the data cable from the Signaline WDM-KM Control Module to a 24Vdc, 30mA suitable power supply. DO NOT SWITCH ON.
- Connect the green, orange, blue and yellow cores of the data cable from the Signaline WDM-KM Control Module to local alarms, building management system or water detection alarm system as required.
- A normally open volt free relay contact (alarm output) and a normally closed opto-isolated output (fault output) are provided for connection to external monitoring and alarm equipment, such as a conventional water detection alarm control panel.
- The fault output opens on loss of power to the Signaline WDM-KM Control Module or if the Signaline WD Water Detection Cable is open circuit.

**LGM PRODUCTS LTD  
UNIT 15 RIVERSIDE INDUSTRIAL PARK  
FARNHAM  
SURREY GU9 7UG  
UNITED KINGDOM**

**TEL +44 (0) 1252 725257  
FAX +44 (0) 1252 727627  
E-mail [sales@lgmproducts.com](mailto:sales@lgmproducts.com)  
[www.signaline.com](http://www.signaline.com)**



# SIGNALINE

## Signaline WDM-KM Control Module Instruction Manual

Two examples of typical water detection layout schematics.

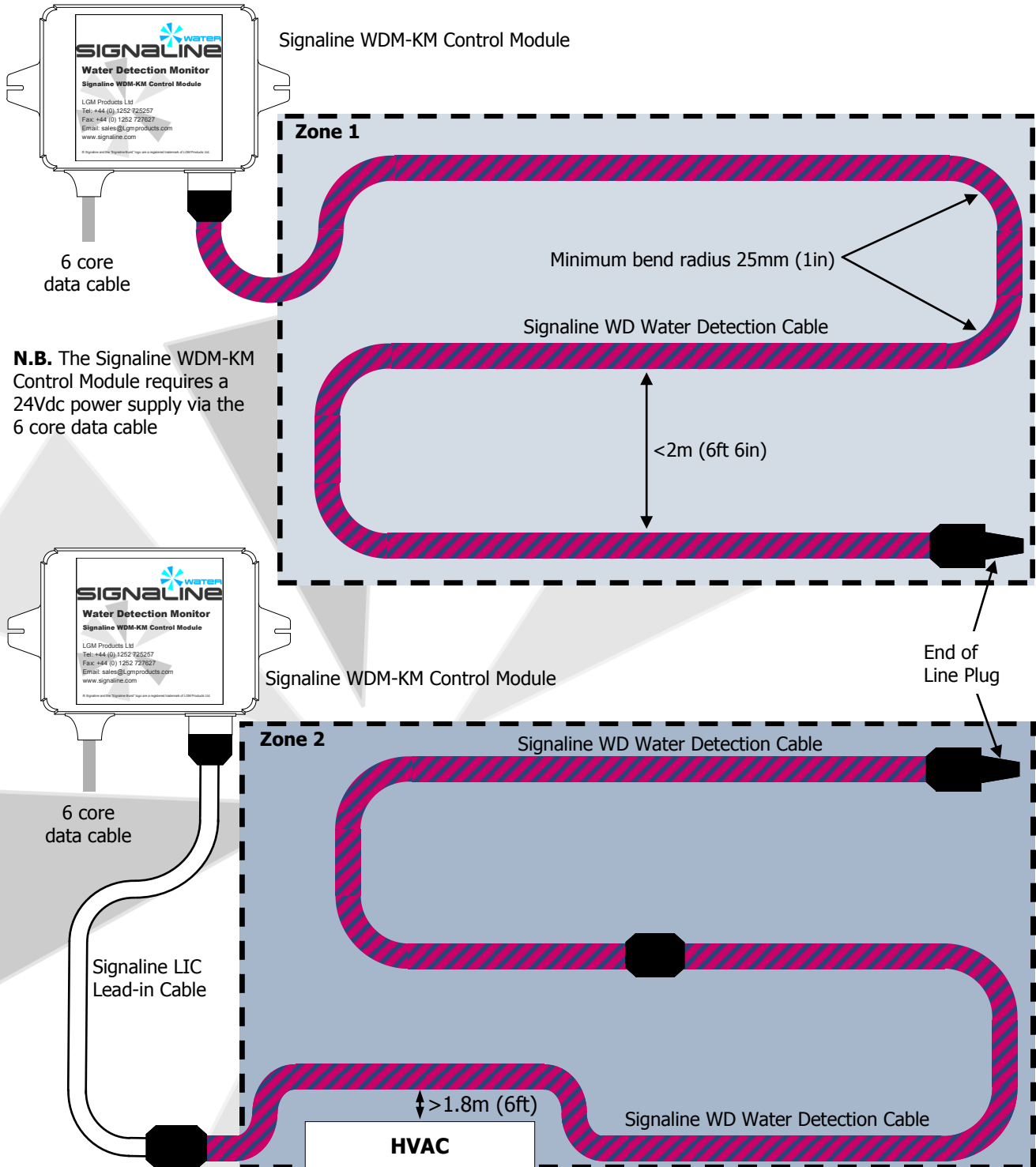

**LGM PRODUCTS LTD**  
**UNIT 15 RIVERSIDE INDUSTRIAL PARK**  
**FARNHAM**  
**SURREY GU9 7UG**  
**UNITED KINGDOM**

**TEL +44 (0) 1252 725257**  
**FAX +44 (0) 1252 727627**  
**E-mail sales@Lgmproducts.com**  
**www.signaline.com**

## Signaline WDM-KM Control Module Instruction Manual

Signaline WDM-KM Control Module

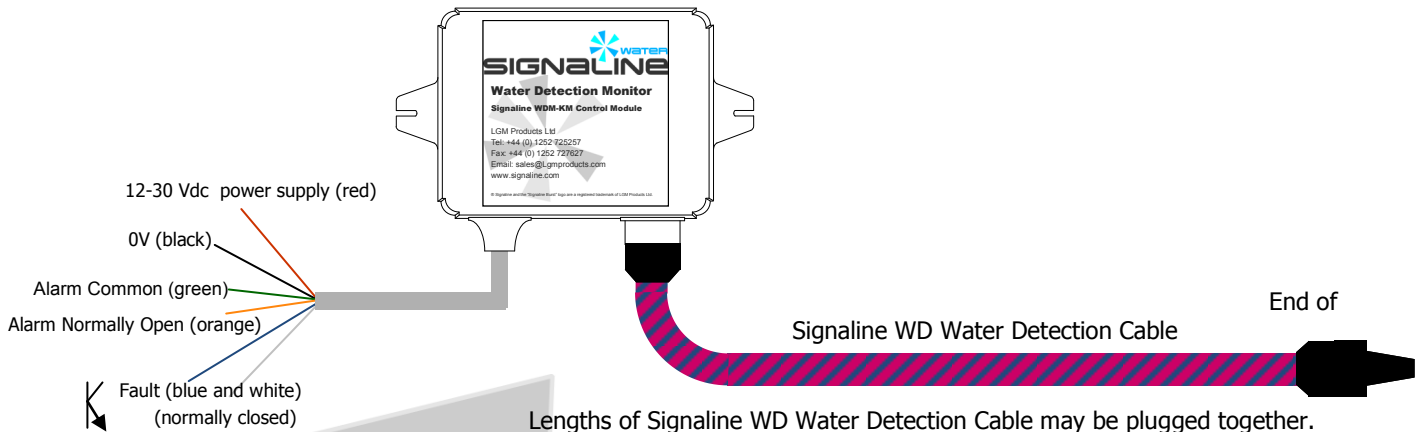

Lengths of Signaline WD Water Detection Cable may be plugged together. A 10 metre pre-terminated non-sensing leader cable is available to connect the control monitor to the start of the sensor cable.

### Output Signal Specification:

#### Alarm Water Detected

Normally Open Volt Free Contacts  
 1A, 30Vdc (resistive load)  
 0.3A, 110Vdc (resistive load)

#### Fault

Normally closed opto-isolated output  
 (opening on power loss or open circuit of detection cable)  
 20mA, 48Vdc (resistive load)

### Important Note:

The fault output circuit is not current limited. Exceeding the specified current limit on the fault output will damage the fault output circuit beyond repair.



## Signaline WDM-KM Control Module Instruction Manual

### TESTING THE SYSTEM:

- Ensure the installed Signaline WD Water Detection Cable is clean and dry.
- Ensure any monitoring equipment connected to the Signaline WDM-KM Control Module is switched on and indicating normal/healthy condition.
- Switch on power to the Signaline WDM-KM Control Module. Any monitoring equipment connected to the Signaline WDM-KM Control Module should continue to indicate normal/healthy condition.
- Disconnect or switch off the power supply to the Signaline WDM-KM Control Module. A fault signal should be triggered on any monitoring equipment connected to the Signaline WDM-KM Control Module. Restoring power to the module should remove the fault signal and return to normal/healthy condition.
- Disconnect the Signaline WD Water Detection Cable from the Signaline WDM-KM Control Module. A fault signal should be triggered on any monitoring equipment connected to the Signaline WDM-KM Control Module. Reconnecting the Signaline WD Water Detection Cable to the module should remove the fault signal and return to normal/healthy condition.
- Disconnect the end of line plug from the Signaline WD Water Detection Cable. A fault signal should be triggered on any monitoring equipment connected to the Signaline WDM-KM Control Module. Reconnecting the end of line plug should remove the fault signal and return to normal/healthy condition.
- **Water Test:** Fill a tray or similar container with a reasonable amount of water. Dip the Signaline WD Water Detection Cable into the water so that the Signaline WD Water Detection Cable is submerged to at least half the diameter of the cable. An alarm condition should be triggered on the monitoring equipment connected to the Signaline WDM-KM Control Module. Remove the Signaline WD Water Detection Cable from the water and gently dry the cable with a paper towel along the wet area. Resetting the monitoring equipment connected to the Signaline WDM-KM Control Module will remove the alarm condition. It may be necessary to wait up to 30 minutes before the alarm signal can be cleared, particularly in hot humid environments. Performing this test at either ends of the Signaline WD Water Detection Cable verifies that the entire length of Signaline WD Water Detection Cable is operative.

**LGM PRODUCTS LTD  
UNIT 15 RIVERSIDE INDUSTRIAL PARK  
FARNHAM  
SURREY GU9 7UG  
UNITED KINGDOM**

**TEL +44 (0) 1252 725257  
FAX +44 (0) 1252 727627  
E-mail [sales@Lgmproducts.com](mailto:sales@Lgmproducts.com)  
[www.signaline.com](http://www.signaline.com)**



## Signaline WDM-KM Control Module Instruction Manual

### Frequently Asked Questions:

#### 1) What is the best way to secure the Signaline WD Water Detection Cable?

The Signaline WD Water Detection Cable should be firmly attached using self adhesive tape or clips. When using the Signaline WD Water Detection Cable on the floor ensuring the cable does not have any air gaps under it will give the quickest response to a leak. Any gaps between the surface and the cable decreases the response time and increases the required amount of water needed to trigger an alarm. If the Signaline WD Water Detection Cable is to be run alongside a pipe cable ties or equivalent should be used to secure the cable at 20cm (8") intervals to prevent sagging. Once again, any gaps between the piping and cable will decrease the response time and increase the required amount of water needed to trigger an alarm.

#### 2) How can I check the integrity of the cable?

The Signaline WDM-KM Control Module continuously monitors the Signaline WD Water Detection Cable for faults along the length of cable. Signaline WD Water Detection Cable can be tested as per points 7 & 8 in the installation instructions proceeding.

#### 3) Can Signaline WD cable be laid directly on metal surfaces?

Yes. The Signaline WD Water Detection Cable is constructed to minimise false alarms, as it is surrounded by a nonconductive polymer braid. This prevents the sensitive parts of the cable from touching conductive materials. (Care should be taken to prevent protruding conductive parts from going through the braid).

#### 4) How much water is needed to trigger the Signaline Water Detection System?

The Signaline WDM-KM Control Module and Signaline WD Water Detection Cable has the ability to detect very small amounts of water such as a saucer of water. Remember, water must come into physical contact with the Signaline WD Water Detection Cable to activate an alarm.

#### 5) What should I do if there are areas in a zone which do not require Signaline WD Water Detection Cable?

For sections of the zone which do not require water sensing cable, Signaline LIC Lead-in Cable is available in 10m (33ft) lengths. The non-sensing cable is a rugged waterproof cable coated in 105°C rated PVC and is pre-terminated for easy connection to the Signaline WD Water Detection Cable. Multiple lengths may be connected together as required.

#### 6) Can the Signaline WDM-KM Control Module be used to switch off the flow of water?

Yes. Many building management systems provide outputs which can be programmed to activate when a certain input is triggered - such as the detection of a water leak. These outputs are often used to activate electric solenoid valves controlling the flow of water. In the majority of cases the alarm volt free relay contacts on the Signaline WDM-KM Control Module will be used to trigger an alarm condition in the building management system. The control panel can then be programmed to activate a particular output operating an electric solenoid valve switching off the flow of water.

**LGM PRODUCTS LTD  
UNIT 15 RIVERSIDE INDUSTRIAL PARK  
FARNHAM  
SURREY GU9 7UG  
UNITED KINGDOM**

**TEL +44 (0) 1252 725257  
FAX +44 (0) 1252 727627  
E-mail [sales@Lgmproducts.com](mailto:sales@Lgmproducts.com)  
[www.signaline.com](http://www.signaline.com)**



## Signaline WDM-KM Control Module Instruction Manual

**7) Is it possible to locate where along the Signaline WD Water Detection Cable the leak has occurred?**

No. The Signaline WDM-KM Control Module does not give an indication of where along the Signaline WD Water Detection Cable the leak has occurred.

**8) Can Signaline LIC Lead-in Cable be used if the Signaline WDM-KM Control Module is located some distance from the area requiring protection?**

Yes, Signaline LIC Lead-in Cable may be used as non-sensing leader cable so the Signaline WDM-KM Control Module may be located away from the area requiring protection if necessary. Multiple lengths of Signaline LIC Lead-in Cable may be connected together.

**9) Can the Signaline WDM-KM Control Module communicate with serial protocols (RS232/RS485) or addressable systems?**

The Signaline WDM-KM Control Module cannot communicate directly with serial protocols, however, industry standard modules are available which can expand the functionality of the Signaline WDM-KM Control Module. For example, the Advantech ADAM4052 module can link up to four Signaline WDM-KM Control Modules (2 channels per module) to an RS485 or RS232 network. In a similar manner, many manufacturers of addressable systems supply addressable zone monitors allowing conventional Signaline Cables such as the Signaline WDM-KM Control Module to be connected.

**LGM PRODUCTS LTD  
UNIT 15 RIVERSIDE INDUSTRIAL PARK  
FARNHAM  
SURREY GU9 7UG  
UNITED KINGDOM**

**TEL +44 (0) 1252 725257  
FAX +44 (0) 1252 727627  
E-mail [sales@Lgmproducts.com](mailto:sales@Lgmproducts.com)  
[www.signaline.com](http://www.signaline.com)**