

Matrix 424 832 832+

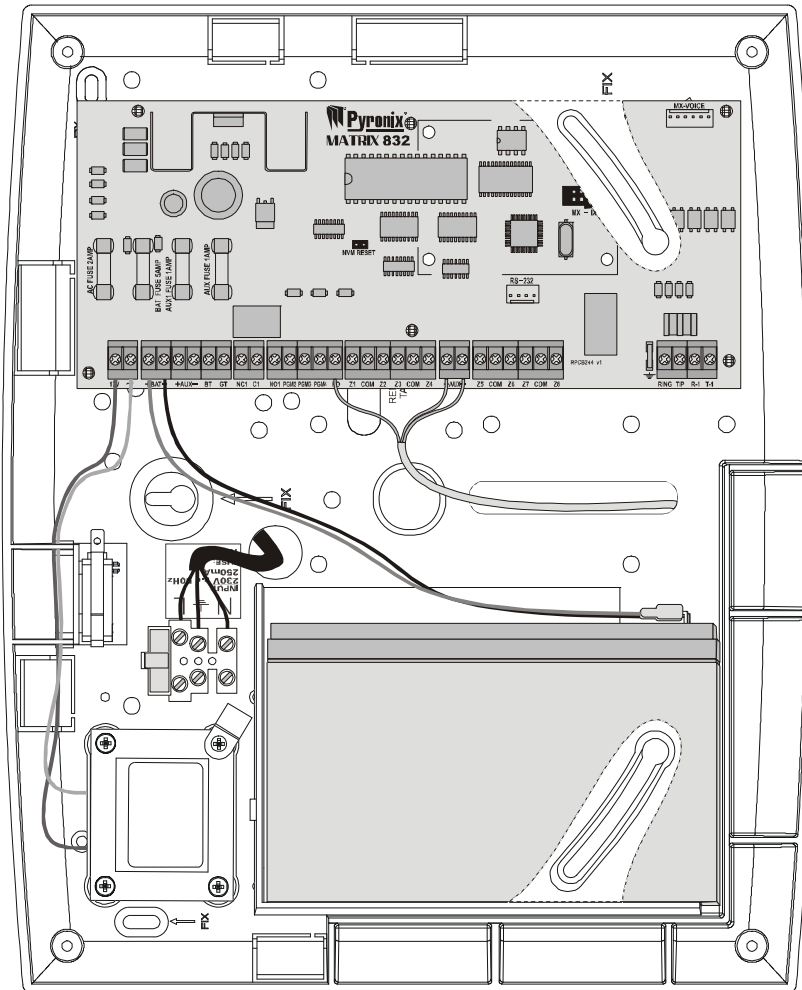

Installation Manual

Software Version 5



RINS918-3



EN50131-1
Security Grade 2
Environmental Class 2

CONTENTS

1. INSTALLATION & CABLING RULES	1
1.1 Tools Required	1
1.2 Mains Wiring.....	1
1.3 Zone/PGM Wiring.....	1
1.4 Battery Wiring.....	1
1.5 Battery Maintenance	1
1.6 Mounting Procedure for Matrix – Plastic & Metal Case	2
1.6.1 Panel Layout – Plastic Case	2
1.6.2 Panel Layout – Metal Case	3
1.7 Battery Installation Procedure	3
1.8 Cabling Rules for the Matrix Bus.....	3
1.8.1 Table 1: KEN (Keypad Equivalent Number) values for each serial module	4
1.8.2 Table 2: Number of 'KENs' Allowed for different Cable lengths	4
1.8.3 System Examples	4
1.9 Addressing the Keypads & Proximity Readers	6
1.10 Finding Bus Devices.....	6
2. WIRING DIAGRAMS	7
2.1 Matrix 424 PCB	7
2.2 Matrix 832 PCB	8
2.3 Matrix 832+ PCB	9
2.4 Power Supply Wiring.....	10
2.5 Telephone Line Wiring	10
2.6 Keypads & Proximity Readers Wiring	11
2.6.1 Connecting a Single Keypad to a Matrix 424.....	11
2.6.2 Connecting a Single Keypad to a Matrix 832.....	11
2.6.3 Connecting a Single Keypad to a Matrix 832+.....	12
2.6.4 Connecting Multiple Keypads / Proximity Readers to a Matrix 424	13
2.6.5 Connecting Multiple Keypads / Proximity Readers to a Matrix 832	14
2.6.6 Connecting Multiple Keypads / Proximity Readers to a Matrix 832+	15
2.7 Matrix Voice Module.....	16
2.7.1 MX-VOICE Module Programming	16
2.8 Battery Monitor Board Wiring	17
2.8.1 How the Battery Monitor Board Works.....	17
2.9 Matrix Zone Expanders	18
2.9.1 Local Plug-On 8 Zone Expander MX-IX16.....	18
2.9.2 Remote 8 Zone Expander MX-RIX with Zone Analyser	19
2.9.3 Wiring 28 Zones to Matrix 424	21
2.9.4 Wiring 32 Zones to Matrix 832	22
2.9.5 Wiring 32 True Zones to Matrix 832+.....	23
2.10 Matrix PGM Expanders	24
2.10.1 Transistor Output Expander MX-ROX8T	24
2.10.2 Relay Output Expander MX-ROX8R.....	24
2.11 Matrix Wireless Expanders	25
2.11.1 Wiring 32 true zones with the wireless expander to a Matrix.....	26
2.12 Zone Wiring	27
2.12.1 Normally Closed Zones Connection to Matrix 424	27
2.12.2 Normally Closed Zones Connection to Matrix 832 (832+).....	27
2.12.3 Single End of Line Zones (Alarm zones – no tamper) Connection to Matrix.....	28
2.12.4 Double End of Line Zones Connection to Matrix	29
2.12.5 Zone Doubling to Matrix	30
2.13 Programmable Outputs Wiring.....	31
2.13.1 External Sounder Connection to Matrix 424	31
2.13.2 External Sounder Connection to Matrix 832	31
2.13.3 External Sounder Connection to Matrix 832+	32
2.13.4 TWIN ALERT Internal Sounder Connection to Matrix 424	32
2.13.5 TWIN ALERT Internal Sounder Connection to Matrix 832 (832+).....	33
2.13.6 Buzzer, LED & Any Siren Connection to Matrix.....	33
2.13.7 Vocaliser Connection to Matrix 832 (424).....	34
2.13.8 Vocaliser Connection to Matrix 832+	34
2.14 Fire Detector Connection to Matrix	35
2.14.1 Two Wire Fire Detector Wiring.....	35
2.14.2 Four Wire Fire Detector Connection to Normally Closed Zone	35

2.14.3 Four Wire Fire Detector Connection to End of Line Zones	36
3. OPERATING MODES AND KEYPAD/READER INDICATIONS	37
3.1 Disarmed and Armed Modes	37
3.1.1 Available Arm Modes	37
3.1.2 Alarm Mode	37
3.1.3 First to Alarm Mode (FTA)	37
3.2 Entry/Exit Mode	37
3.3 Keypad Layout & Button Meanings	38
3.4 ICON Keypad Indication	39
3.5 LCD Keypad Indication	40
3.6 Proximity Reader Indication	40
3.7 Keyfob Layout and Button Meanings	41
3.7.1 The KF4DW Actions	41
3.7.2 STATUS LEDS	41
4. SYSTEM OVERVIEW & TECHNICAL SPECIFICATIONS	43
4.1 System Overview	43
4.1.1 Zones	43
4.1.2 Programmable Outputs (PGM)	43
4.1.3 Keypads	44
4.1.4 Proximity Reader (Not approved for use in Denmark, Finland, Norway or Sweden)	44
4.1.5 Partitions	44
4.1.6 User Codes	44
4.1.7 Central Monitoring Options	45
4.1.8 Other	45
4.2 Minimum Installation Requirements	45
4.3 Technical Specification	46
4.3.1 Main Control Panel	46
4.3.2 Keypads, Proximity Reader & Additional Expanders	47
4.4 Battery Capacity Calculations	48
4.4.1 Norwegian & Danish Requirements	48
4.4.2 Swedish Requirements	48
5. SAFETY & APPROVALS	49

1. INSTALLATION & CABLING RULES

Before mounting the panel you must decide on the place of installation. The use of remote keypads mean that the panel can be located anywhere on the premises and it is recommended that the panel be housed in a concealed place.

IMPORTANT:

1. Before any work is undertaken it is highly recommended that the mains supply be isolated to reduce the risk of electric shock.

2. Before handling or touching any of the bare PCBs, you should make every effort to reduce the amount of static electricity that the boards may be exposed to.

1.1 Tools Required

The Matrix alarm panel and associated devices use standard screws for all serviceable parts. No other special tools are required.

Action / Serviceable Part	Tool Required
Remove the case lid (panel + expanders)	Pozi-drive No.3
Mains input terminals	Slotted 4mm
Zone terminals (panel and expanders)	Slotted 3mm
Battery terminals on main PCB	Slotted 3mm
MX-BATT terminals	Slotted 3mm
Remove LCD/ICON keypad rear cover	Pozi-drive No.0

1.2 Mains Wiring

The matrix panel has a standard 3-way mains input connector block with integrated supply fuse protection. The connector block connections are indicated on the panel case with an associated mains input sticker. This sticker indicates Live (L), Neutral (N) and Earth, as well as the mains supply voltage rating.

1.3 Zone/PGM Wiring

To minimise false signals on the zone connections it is recommended that no part of the wiring be allowed to short to adjacent connectors. Strip back only enough sleeving from the wire as necessary before inserting it all the way into the connector, as far as it will go. When placing more than one wire into a single terminal make sure that all the wires are pushed in firmly as far as they will go, before tightening the terminal screw. Do not join multiple wires together before inserting into the terminal block, as this is a common cause of faulty wiring causing false alarms.

When linking out unused zones with resistors, again make every effort to ensure that adjacent resistors cannot short out with each other. Keep the resistor leg length short and do not allow resistor legs to overlap with each other.

1.4 Battery Wiring

The battery wiring is very similar to the zone/PGM wiring as the same type of terminal connections are employed. If you are using an MX-BATT battery monitor board then you will be wiring to the MX-BATT BAT IN connector and not to the Matrix alarm panel PCB.

The battery connection is polarized. You must ensure that the positive terminal of the battery is connected to the BAT+ terminal on the Matrix alarm panel (BAT IN+ on the MX-BATT PCB), and that the negative terminal of the battery is connected to the BAT- terminal on the Matrix alarm panel (BAT IN – on the MX-BATT PCB).

1.5 Battery Maintenance

The Matrix alarm panel constantly monitors the battery voltage and will provide suitable battery low/fail warnings in the event of a battery problem. A system fault 4 indicates a low battery. System fault 3 indicates a missing/dead battery. When replacing a battery only use the recommended battery type and rating. See the Technical Specification Section for full details.

1.6 Mounting Procedure for Matrix – Plastic & Metal Case

The following steps illustrate basic mounting procedure for matrix plastic & metal case. (See Section 2 for complete wiring diagrams)

Step 1 - Remove the case lid from the matrix panel and check all parts and components are in place.

Step 2 - Decide where the matrix panel will be situated. The matrix panel may be housed in the loft or different rooms in the premises. A discrete and concealed place is advisable, as only the Matrix keypads need to be seen.

Step 3 - Secure the matrix panel to a sturdy and stable surface, using the mounting screws provided. First mark the wall where the panel is to be situated (using the mounting holes), drill holes in the wall, and fasten the panel base to the wall using the screws supplied.

Step 4 - Before the panel base is completely secured to the wall feed cables for keypads / AC power supply / and accessories through the cable entry holes as illustrated.

1.6.1 Panel Layout – Plastic Case

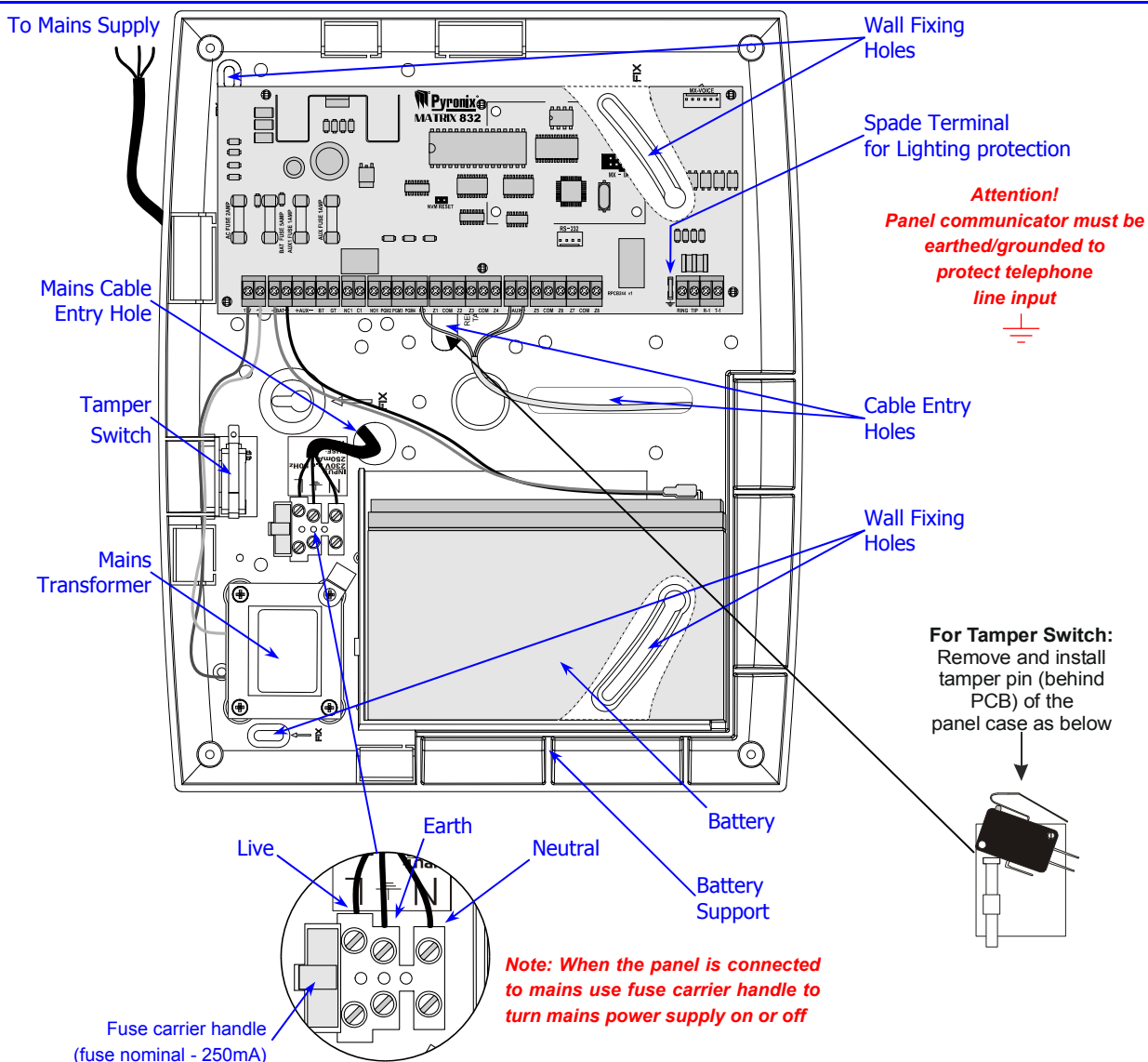

1.6.2 Panel Layout – Metal Case

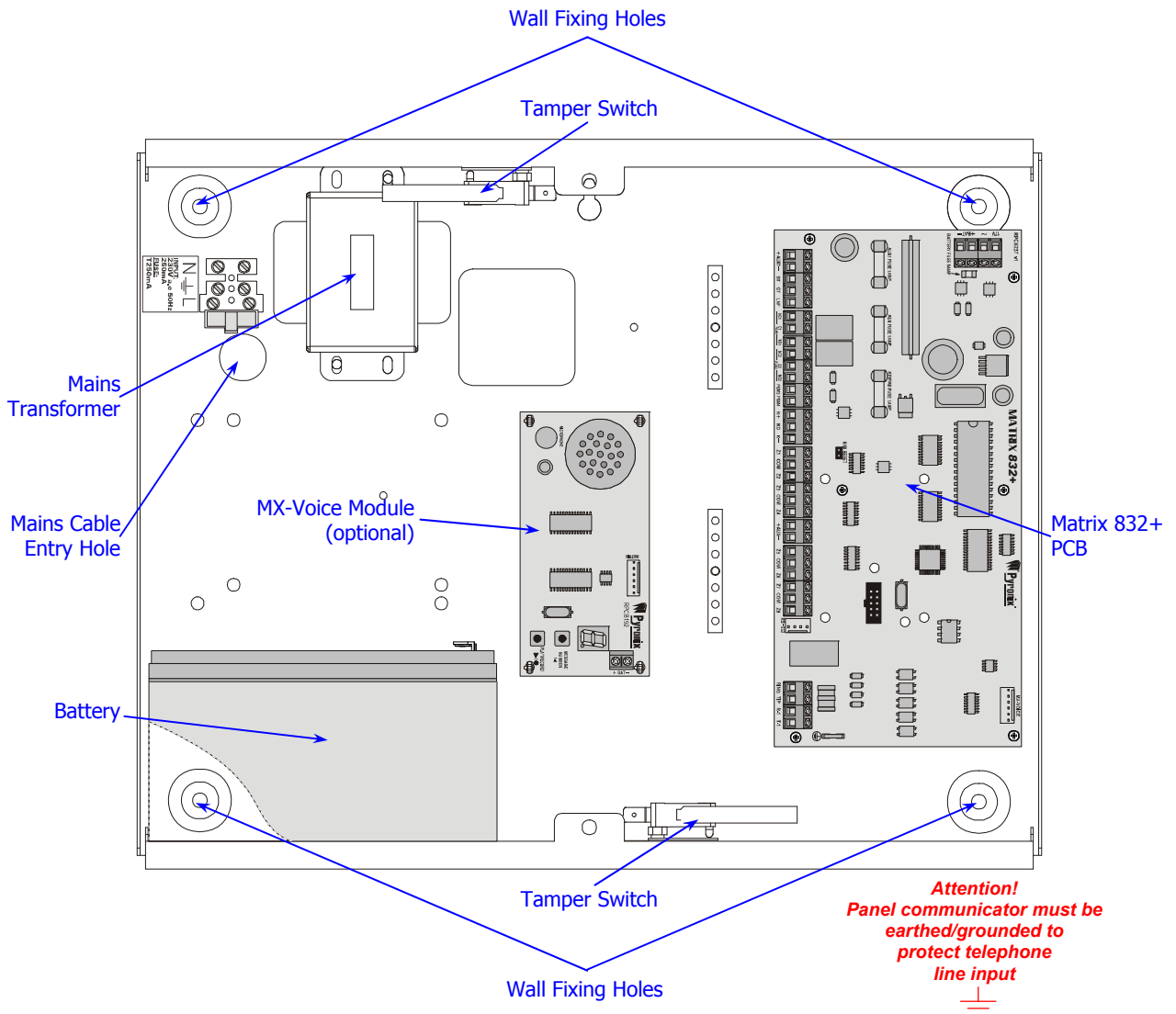

1.7 Battery Installation Procedure

Place two foam pads on the bottom of the battery and two on the upper rear. Place the battery in the case and secure with two tie wraps.

1.8 Cabling Rules for the Matrix Bus

Care must be taken when connecting devices to the bus over long cable runs. This is to ensure maximum system integrity under all circumstances (battery backup, etc.). Pyronix recommends using standard 0.22mm cross sectional area, shielded multi-core alarm cable for the Matrix bus.

The maximum number of external devices connected to the bus on any one system is limited to six - this may not be exceeded. Although six is the system limit other restrictions apply to each cable run. It is important to restrict the amount of current carried along each length of cable to limit voltage drops across the system. Apart from being affected by current magnitude, voltage drops are also dependent upon the length of cable and the types of devices fitted. The following tables provide a means of determining suitable cable run configurations for different systems.

NOTE: It is the length of cable between panel and end device that is important rather than the overall length on the entire bus.

1.8.1 Table 1: KEN (Keypad Equivalent Number) values for each serial module

DEVICE	Description and Configuration	KEN
MX-LCD	Matrix LCD Keypad	3
MX-RIX	Matrix Remote Zone Expander	1
MX-RIX8DW	Matrix Wireless Expander	3
MX-PROX	Proximity Reader	2
MX-ROX8R	8 Way Relay Output Module *1 *2	4
MX-ROX8T	8 Way Transistor Output Module (max. total transistor outputs current sink < 30mA)	1
MX-ROX8T	8 Way Transistor Output Module (max. total transistor outputs current sink < 90mA)	2
MX-ROX8T	8 Way Transistor Output Module (max. total transistor outputs current sink < 150mA)	3
MX-ROX8T	8 Way Transistor Output Module (max. total transistor outputs current sink < 210mA)	4
MX-ROX8T	8 Way Transistor Output Module (max. total transistor outputs current sink > 210mA)	$1 + \frac{\text{Sink Current(A)} - 0.03}{0.06}$

*1 The Above KEN assignments for Relay type output modules assume that all power supplying the switched contacts (devices switched on/off by the output expander) is supplied via a different feed/ PSU.

*2 Remember that the maximum allowable current-draw from the Matrix for External devices is 0.6A (plastic case) / 1.1A (metal case). Any requirement exceeding this must be provided by a separate power supply. Where a power supply is added for use with an output expander, the 0V of the supply should be connected at the expander.

1.8.2 Table 2: Number of 'KENs' Allowed for different Cable lengths

Length of Cable (meters)	Number of KEN allowed with Single core cable per signal	Number of KENs with standard cable 0V return doubled
100	3	4
75	4	6
50	6	9
25	13	18

1.8.3 System Examples

A Matrix System is required to provide the following:

- 6 PIR Detectors (15mA each)
- A bell-box (max. current draw 400mA) connected to PGM1
- 2 Matrix ICON Keypads (60mA each), one 50m away, and the other 100m away
- A Matrix Transistor Output Expander (30mA) with 3 LEDs (10mA each) and 3 buzzers (12mA each) controlled by the outputs (accompanying the keypad 100m away) power supply.

From the above example, the total current drawn from the panel would be:

TOTAL	Detectors	Bell	RKPs	Output Expander	LEDs	Buzzers
0.706A	6 X 0.015	1 X 0.400	2 X 0.060	1 X 0.030	3 X 0.010	3 X 0.012

The maximum current available for external devices from the Matrix PCB is 0.6A. Therefore, this installation would require an additional power supply.

Before we can calculate an acceptable wiring arrangement we must know the 'KEN' value for each device on the keypad bus. From Table 1 we know that each keypad has a KEN of 1. The Transistor Output expander controls the LEDs and buzzers, which together give a total current of 66mA (3x10mA + 3x12mA). From table 1 a transistor output expander with a current sink of 66mA falls into the <90mA criteria which corresponds with a 'KEN' of 2.

Example 1

The most straightforward wiring approach would be to daisy chain the devices on one run as below.

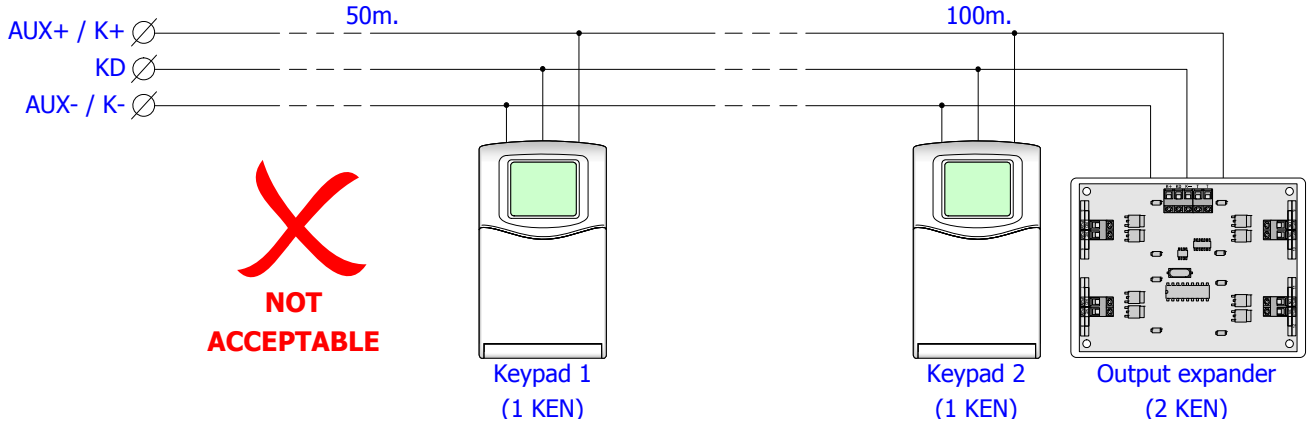

However, this is an unacceptable solution because there are 4 'KEN' on a 100m length of cable. Table 2 shows that a maximum of 3 'KEN' is acceptable on a 100m length of cable – the fact that one keypad is just 50m away does not affect these rules.

Example 2

This is now an acceptable solution because the ground return is shared between 2 cores of cable. Referring to table 2, the second column shows that by doubling up the ground return it is acceptable to have up to 4 'KEN' on a 100m length of cable.

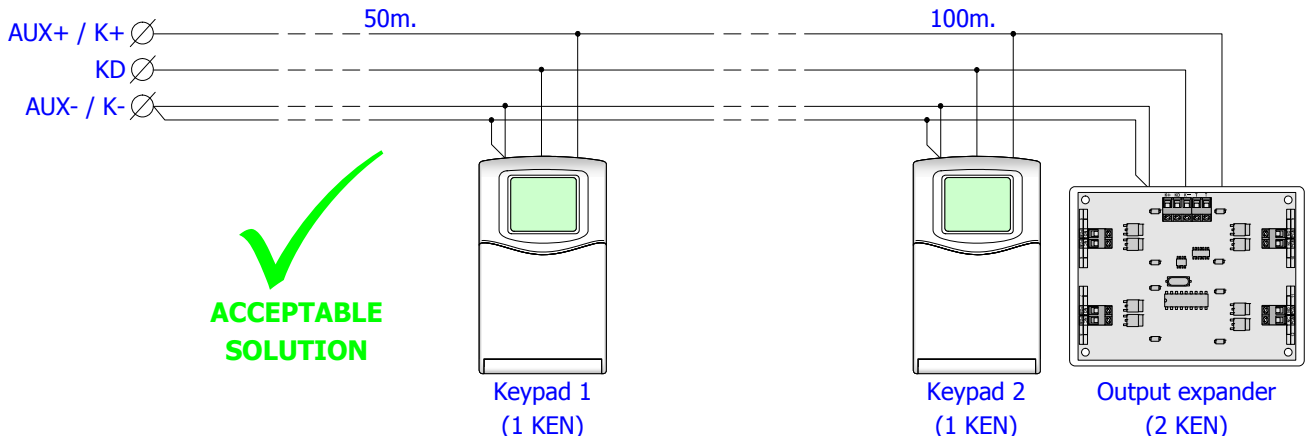

Example 3

This is now an acceptable solution because there are now two separate cables connecting the devices back to the Matrix control panel. The 100m cable is now supporting 3 'KEN' and is now in accordance with table 2, and the 50m cable is supporting 1 'KEN' which is well within the limits.

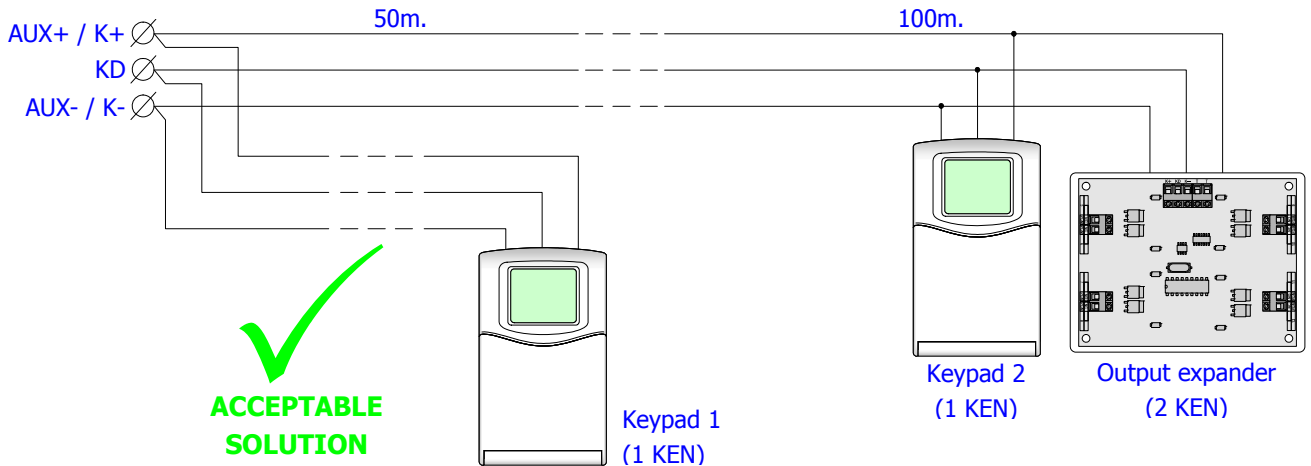

1.9 Addressing the Keypads & Proximity Readers

The LCD and ICON keypads are individually addressable. Each keypad type (LCD & ICON) can have four different addresses. The address of the device is set using the small switch on the keypad PCB. If you have multiple devices of the same type then they must have different addresses (IDs). One keypad **MUST** be set to ID 1. You will need to remove the rear cover from the keypad to gain access to the address switch. The Matrix panel recognizes individual MX PROX readers by the link settings on the back of each reader.

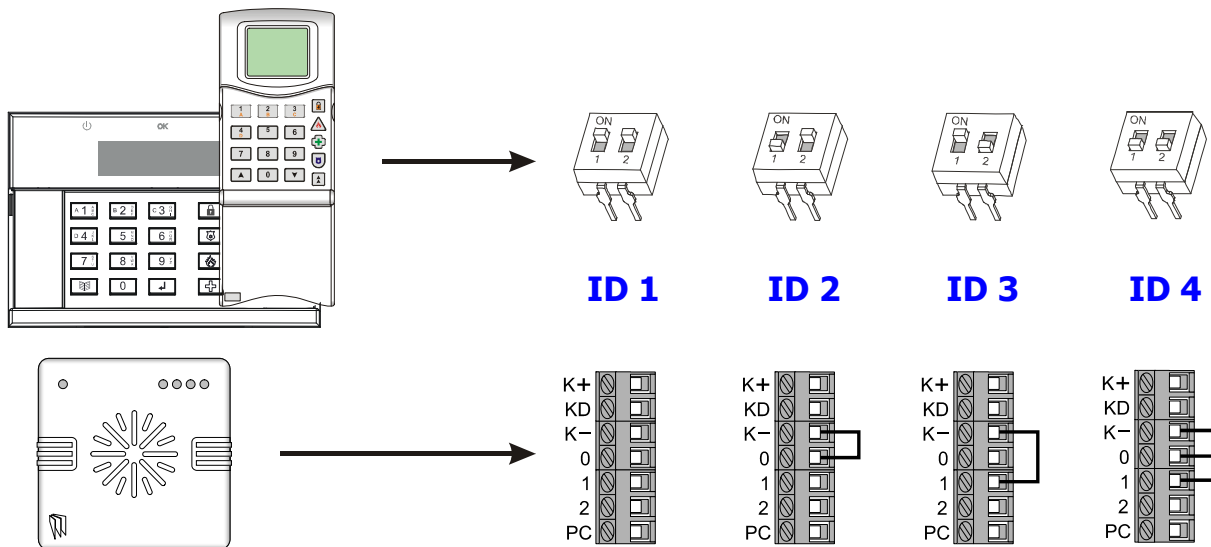

NOTE: Before you start programming the system, use engineers function 754 to scan for all devices on the Matrix bus.

1.10 Finding Bus Devices

Every time you add or remove a device on system bus, you must rescan for bus devices (**▲ 7 5 4**) so that the panel can recognise the new hardware.

2. WIRING DIAGRAMS

GLOBAL TAMPER CONNECTION

Note: The global tamper connections are very important.

The global tamper connections on the 832 and 832+ control panel are GT and AUX-, devices should be connected between these two terminals to create a global tamper loop.

The 424 control panel does not have the GT terminal connection, so a spare zone programmed as Tamper should be used to create the tamper loop.

2.1 Matrix 424 PCB

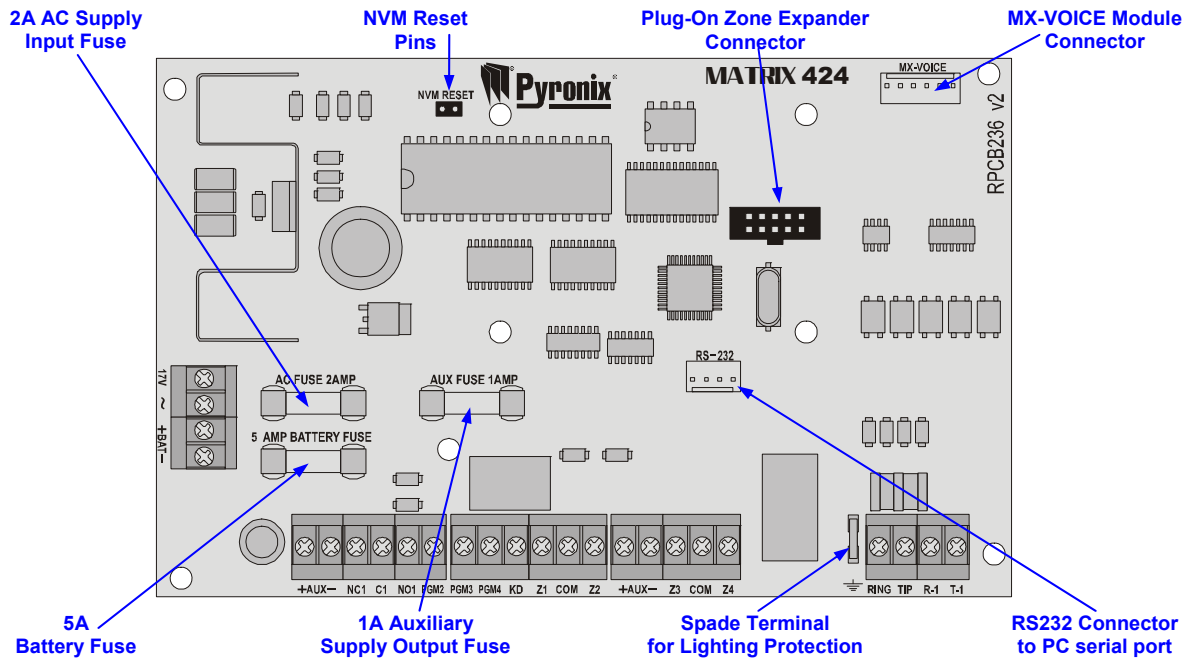

17V~	Mains transformer connections 17VRMS, 21VA or 17V DC, 1.25A supply unit. Protected by a 2A fuse
+BAT-	Battery connections in order for the Matrix to operate without mains supply. Protected by a 5A fuse
+AUX-	Auxiliary supply to the bell. Protected by a 1A fuse
NC1	Programmable relay output 1. Normally closed contact
C1	Programmable relay output 1. Common contact, 30V@3A
NO1	Programmable relay output 1. Normally open contact
PGM2	Programmable output 2. Open collector, 12V@200mA
PGM3	Programmable output 3. Open collector, 12V@200mA
PGM4	Programmable output 4. Current sink, 12V@10mA (current limited to 50mA)
KD	Keypads / expanders data line
Z1	Zone 1 input
COM	Common connection for zones (0V)
Z2	Zone 2 input
+AUX-	Auxiliary supply for detectors, keypads, etc. Protected by a 1A fuse
Z3	Zone 3 input
COM	Common connection for zones (0V)
Z4	Zone 4 input
RING, TIP	Connections to analogue PSTN telephone line
R-1, T-1	To be connected to remaining telephone line equipment within the installation

2.2 Matrix 832 PCB

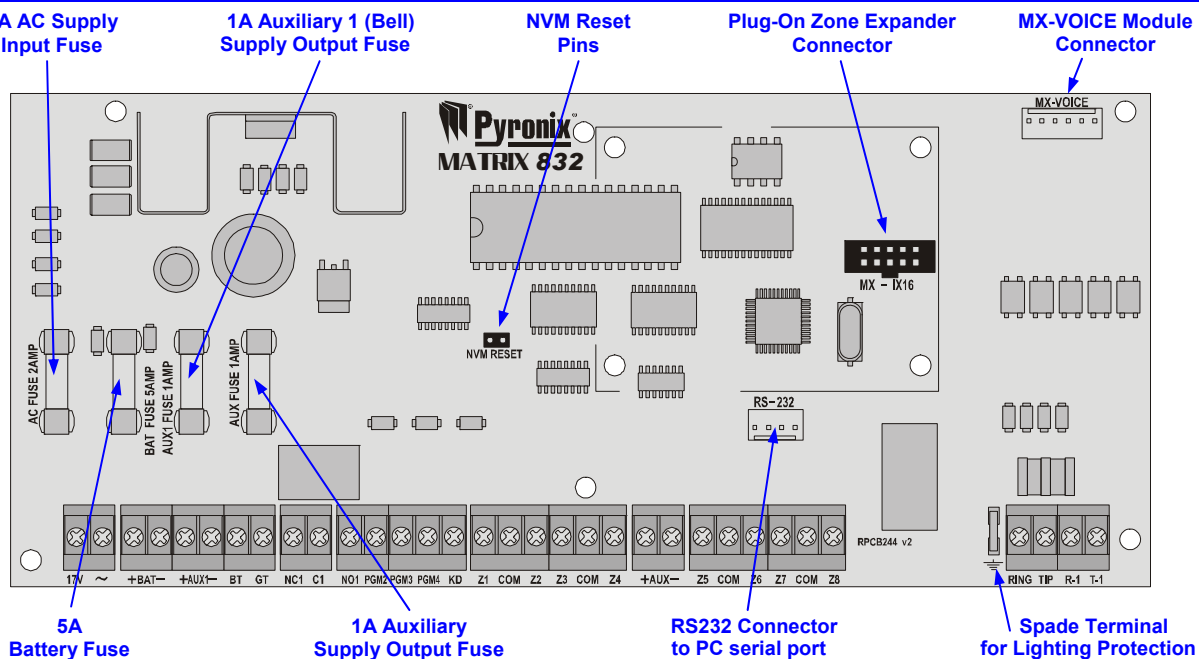

17V~	Mains transformer connections 17VRMS, 21VA or 17V DC, 1.25A supply unit. Protected by a 2A fuse
+BAT-	Battery connections in order for the Matrix to operate without mains supply. Protected by a 5A fuse
+AUX1-	Auxiliary supply to the bell. Protected by a 1A fuse
BT	Bell Tamper – Negative tamper return from bell box (Normal condition connected to 0V)
GT	Global Tamper – Negative tamper return (Normal condition connected to 0V)
NC1	Programmable relay output 1. Normally closed contact
C1	Programmable relay output 1. Common contact, 30V@3A
NO1	Programmable relay output 1. Normally open contact
PGM2	Programmable output 2. Open collector, 12V@200mA
PGM3	Programmable output 3. Open collector, 12V@200mA
PGM4	Programmable output 4. Current sink, 12V@10mA (current limited to 50mA)
KD	Keypads / expanders data line
Z1	Zone 1 input
COM	Common connection for zones (0V)
Z2	Zone 2 input
Z3	Zone 3 input
COM	Common connection for zones (0V)
Z4	Zone 4 input
+AUX-	Auxiliary supply for detectors, keypads, etc. Protected by a 1A fuse
Z5	Zone 5 input
COM	Common connection for zones (0V)
Z6	Zone 6 input
Z7	Zone 7 input
COM	Common connection for zones (0V)
Z8	Zone 8 input
RING, TIP	Connections to analogue PSTN telephone line
R-1, T-1	To be connected to remaining telephone line equipment within the installation

2.3 Matrix 832+ PCB

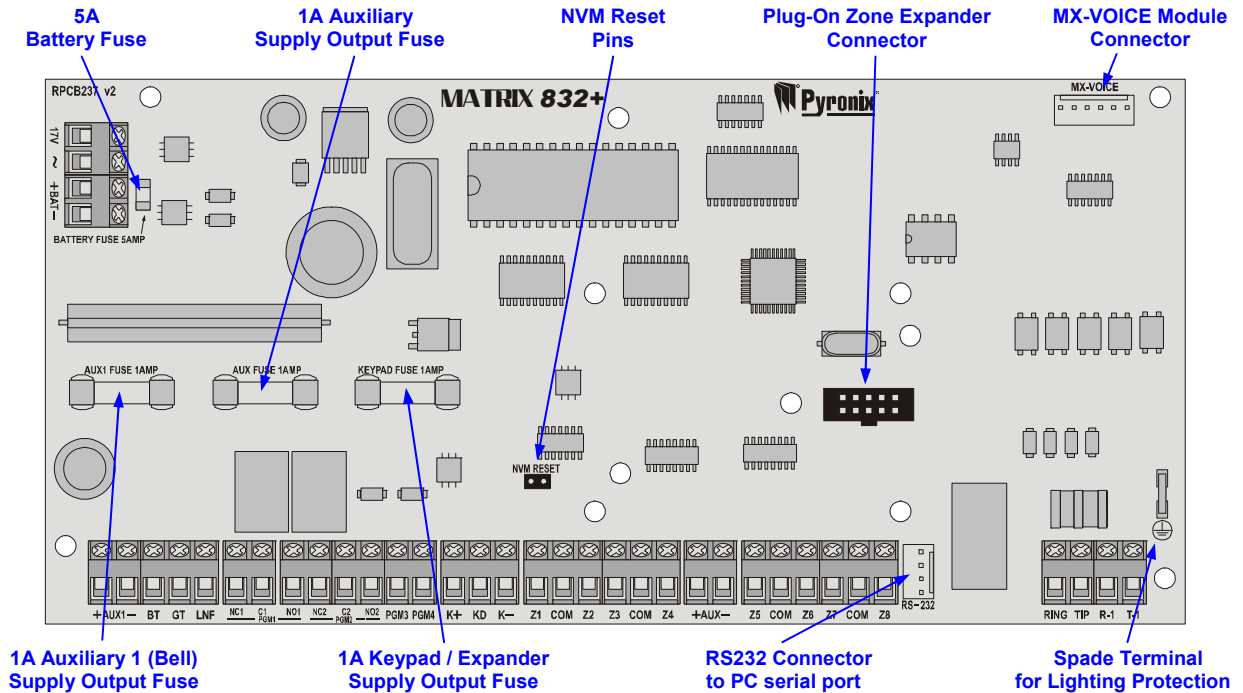

17V~	Mains transformer connections 17VRMS, 44VA for a metal casing / 21VA for a plastic casing or 17V DC, 1.25A supply unit. Protected by a 2A fuse
+BAT-	Battery connections in order for the Matrix to operate without mains supply. Protected by a 5A fuse
+AUX1-	Auxiliary supply to the bell. Protected by a 1A fuse
BT	Bell Tamper – Negative tamper return from bell box (normal condition connected to 0V)
GT	Global Tamper – Negative tamper return (normal condition connected to 0V)
LNF	Telephone line fail input
NC1	Programmable relay output 1. Normally closed contact
C1	Programmable relay output 1. Common contact, 30V@3A
NO1	Programmable relay output 1. Normally open contact
NC2	Programmable output 2. Normally closed contact
C2	Programmable output 2. Common contact, 30V@3A
NO2	Programmable output 2. Normally open contact
PGM3	Programmable output 3. Open collector, 12V@200mA
PGM4	Programmable output 4. Current sink, 12V@10mA (current limited to 50mA)
K+	Positive supply for keypads / expanders. Protected by a 1A fuse
KD	Keypads / expanders data line
K-	Negative supply for keypads / expanders.
Z1	Zone 1 input
COM	Common connection for zones (0V)
Z2	Zone 2 input
Z3	Zone 3 input
COM	Common connection for zones (0V)
Z4	Zone 4 input
+AUX-	Auxiliary supply for detectors, etc. Protected by a 1A fuse
Z5	Zone 5 input
COM	Common connection for zones (0V)
Z6	Zone 6 input
Z7	Zone 7 input
COM	Common connection for zones (0V)
Z8	Zone 8 input
RING, TIP	Connections to analogue PSTN telephone line
R-1, T-1	To be connected to remaining telephone line equipment within the installation

2.4 Power Supply Wiring

NOTE 1: Terminal connections for the Matrix 832 and Matrix 832+ are the same as for the Matrix 424.

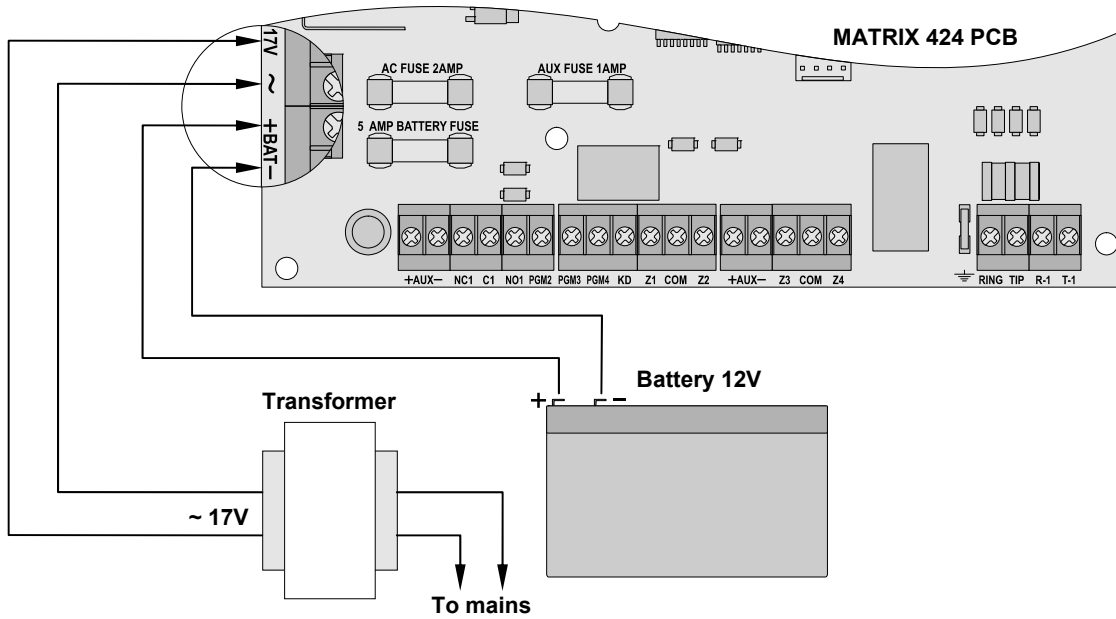

NOTE 2: When the control panel is de-energized, you can apply power from either of the power supply inputs: AC supply via the transformer or 12V DC supply from the battery.

NOTE 3: If necessary it is possible to power the panel using only the +BAT- terminals. In this case it is recommended that a 12V UPS (uninterruptible power supply) is used. AC Monitoring option should be disabled.

2.5 Telephone Line Wiring

Terminal connections for the Matrix 832 and Matrix 832+ are the same as for the Matrix 424.

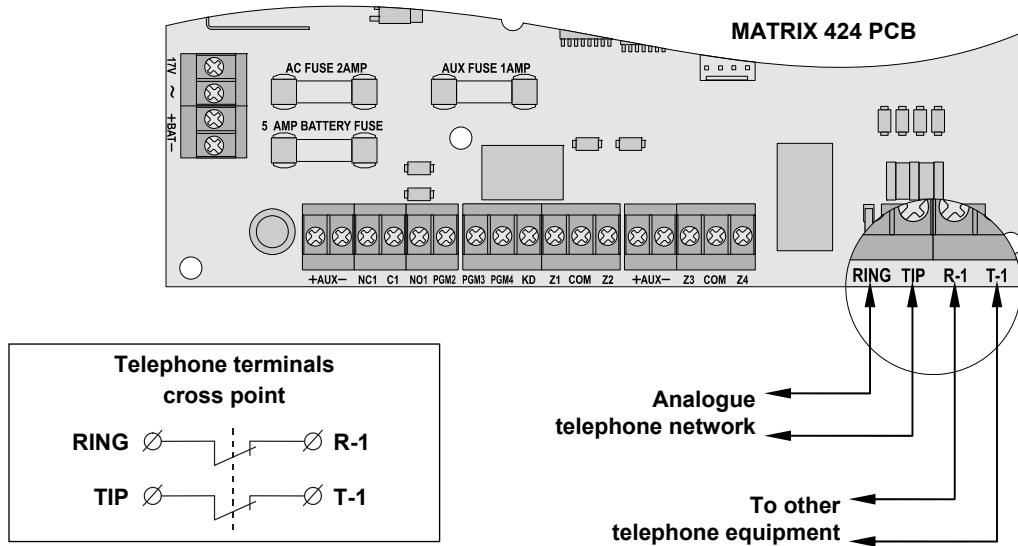

NOTE: Terminals R-1 and T-1 are used for connecting to telephone line equipment which will automatically be disconnected from the telephone line during dial out and UDL session.

2.6 Keypads & Proximity Readers Wiring

NOTE: When connecting keypads to a Matrix panel, the first keypad must always be ID1.

2.6.1 Connecting a Single Keypad to a Matrix 424

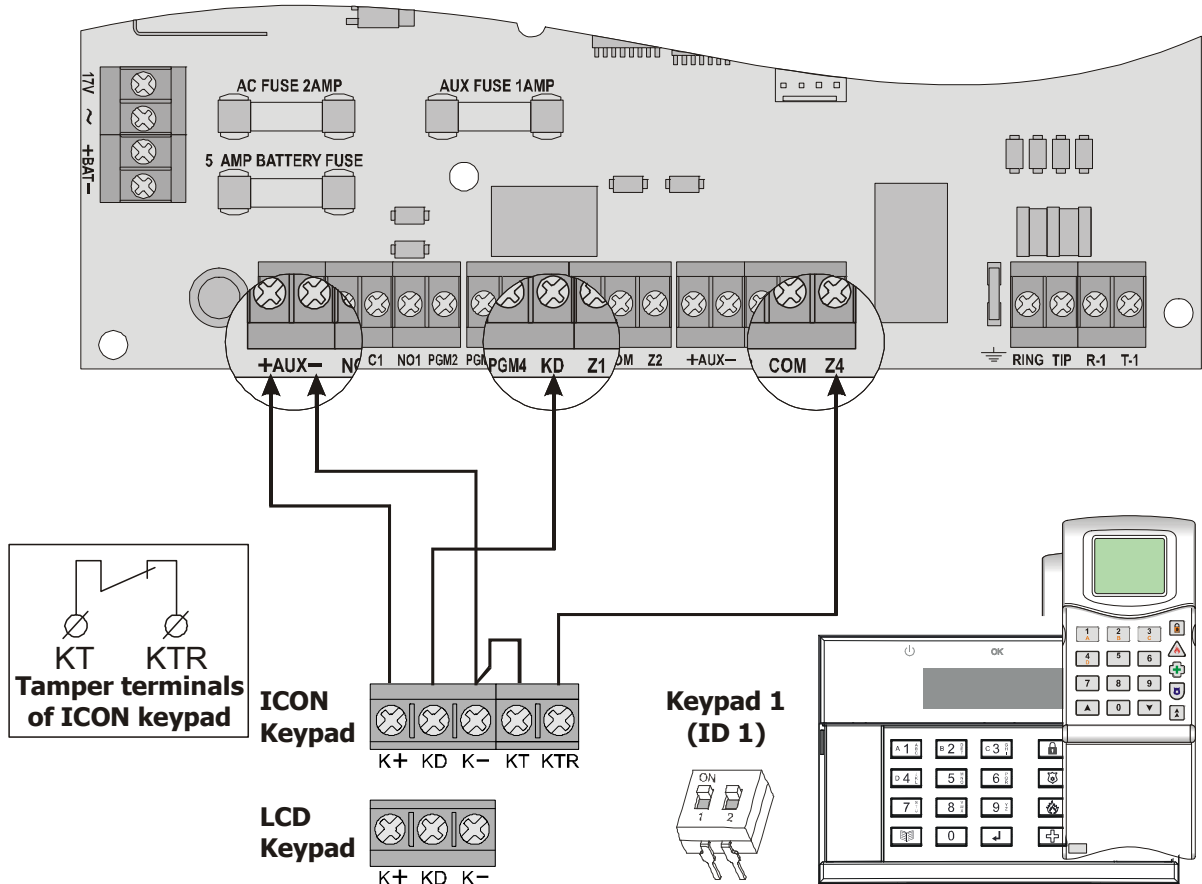

NOTE: Tamper connections must go to a zone programmed as Tamper.

2.6.2 Connecting a Single Keypad to a Matrix 832

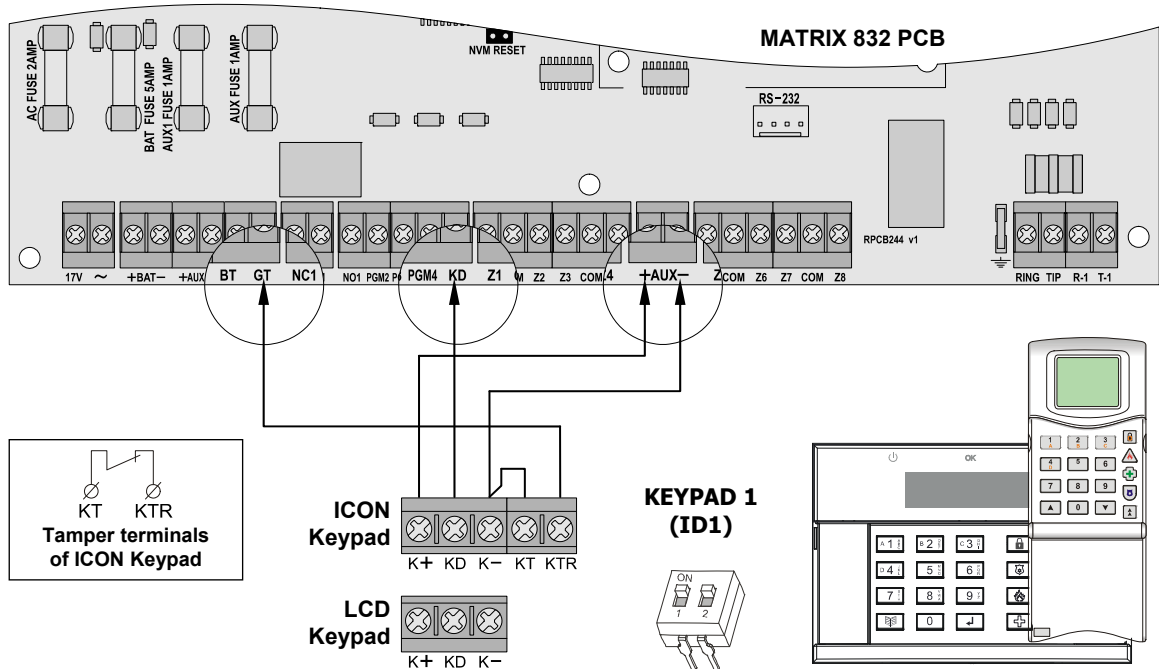

NOTE: After adding or removing equipment from the system, use engineers function 754 to scan for all devices on the Matrix bus.

2.6.3 Connecting a Single Keypad to a Matrix 832+

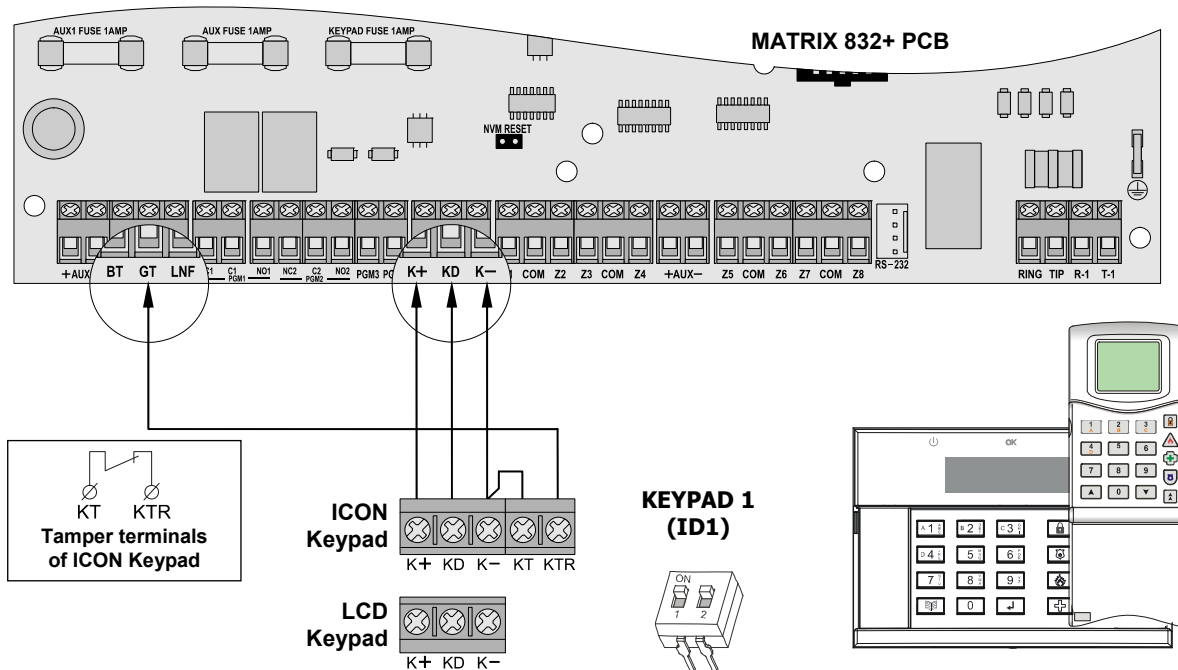

NOTE: After adding or removing equipment from the system, use engineers function 754 to scan for all devices on the Matrix bus.

2.6.4 Connecting Multiple Keypads / Proximity Readers to a Matrix 424

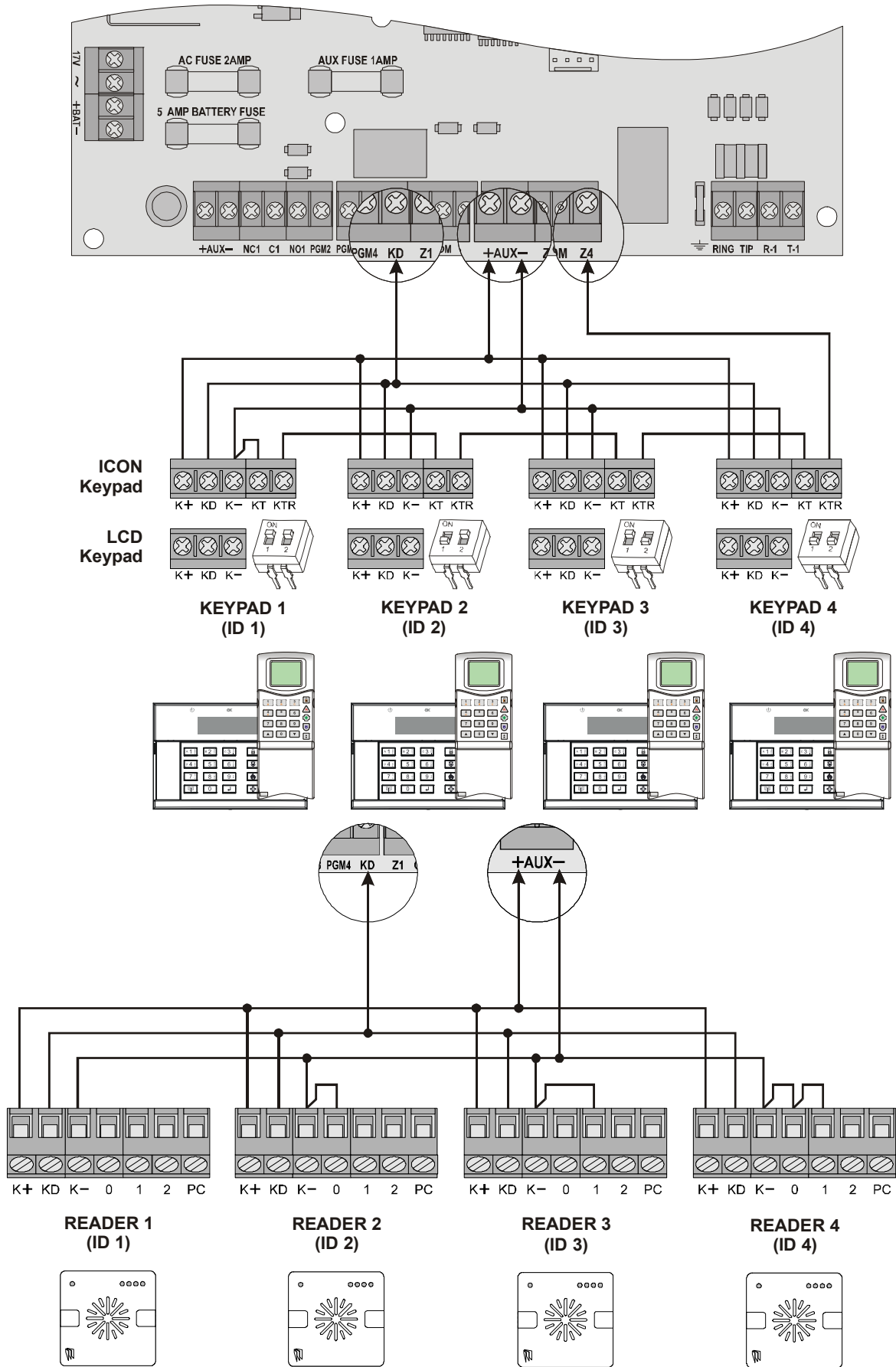

NOTE: Tamper connections must go to a zone programmed as Tamper.

NOTE: After adding or removing equipment from the system, use engineers function 754 to scan for all devices on the Matrix bus.

2.6.5 Connecting Multiple Keypads / Proximity Readers to a Matrix 832

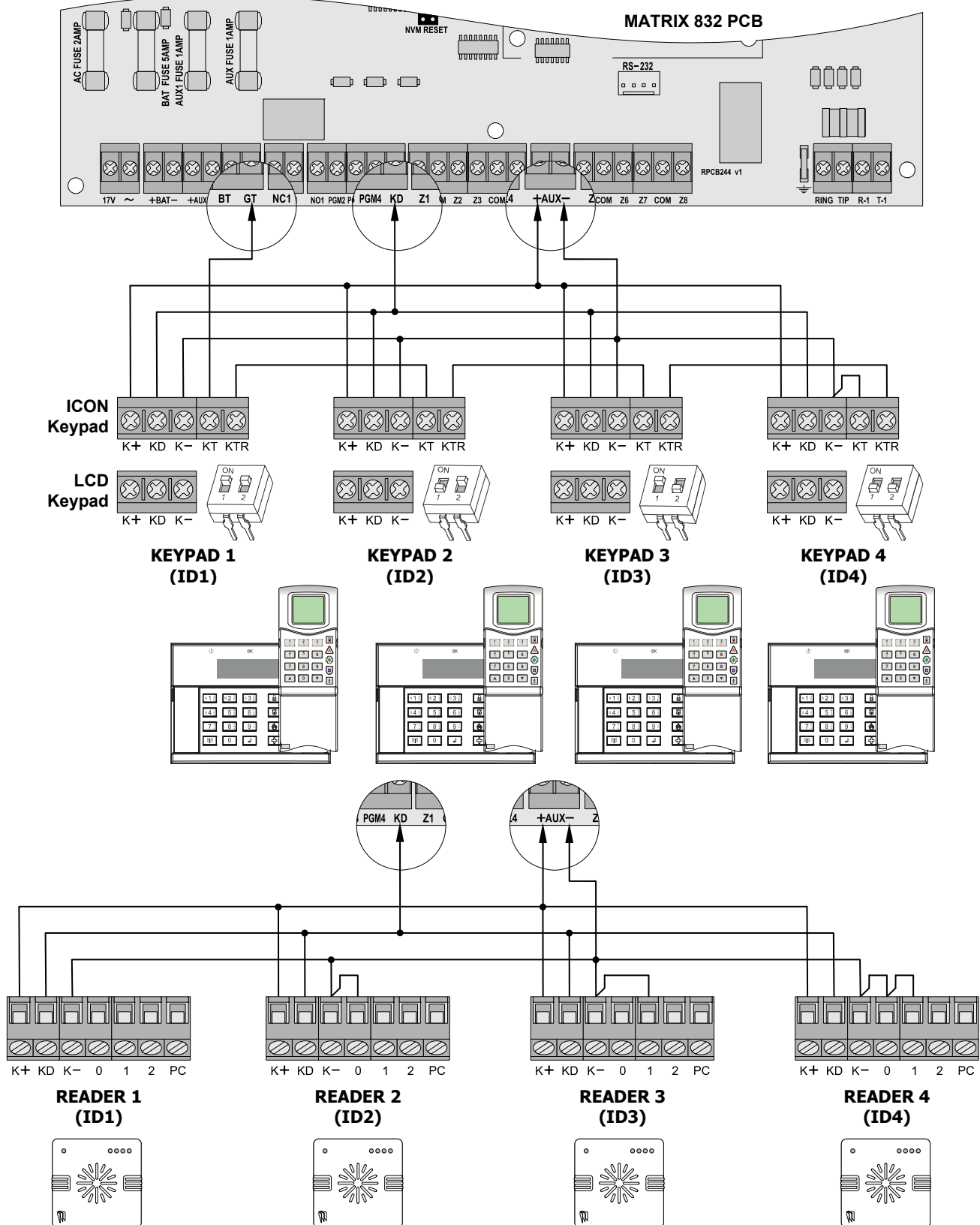

NOTE: After adding or removing equipment from the system, use engineers function 754 to scan for all devices on the Matrix bus.

2.6.6 Connecting Multiple Keypads / Proximity Readers to a Matrix 832+

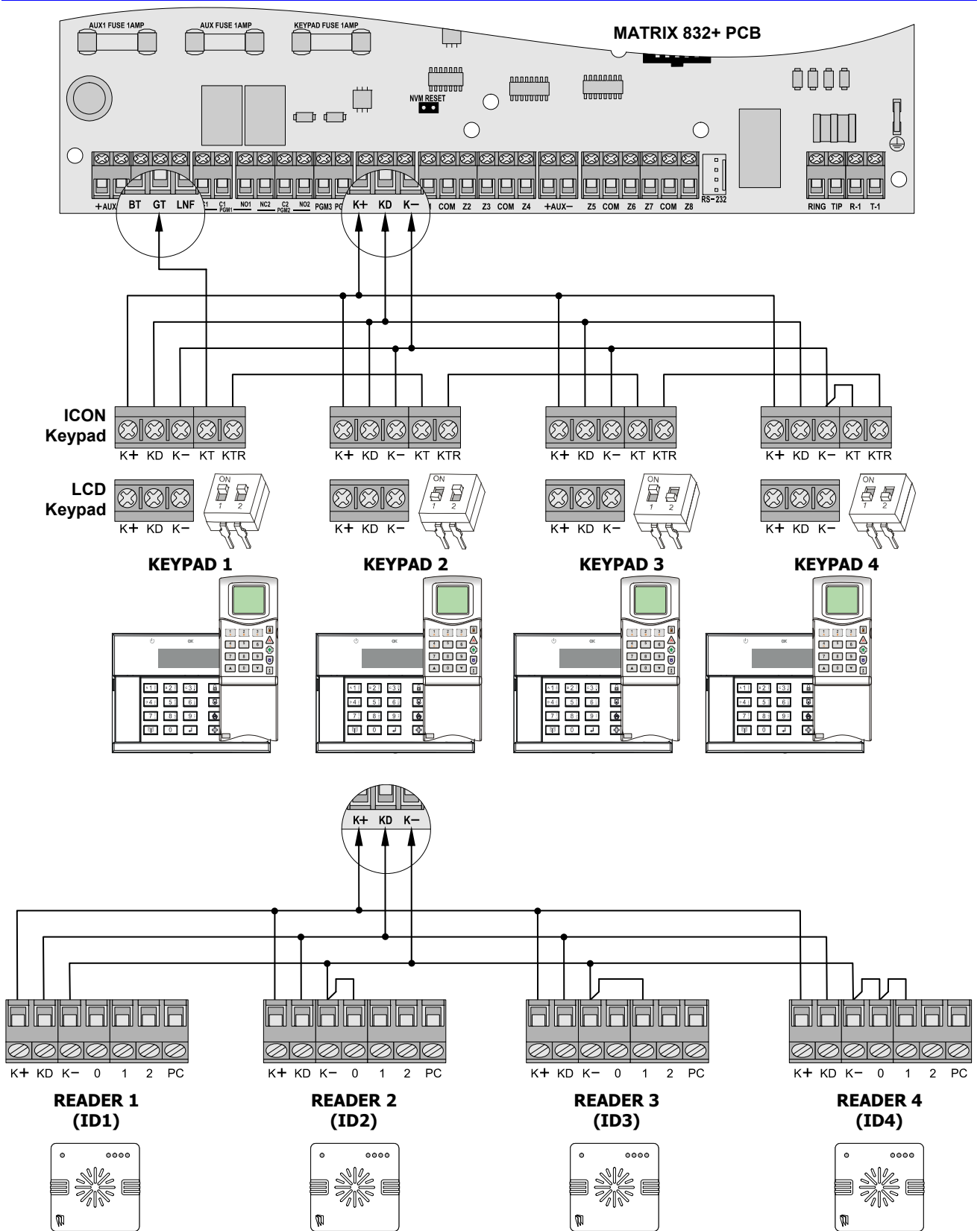

NOTE: After adding or removing equipment from the system, use engineers function 754 to scan for all devices on the Matrix bus.

2.7 Matrix Voice Module

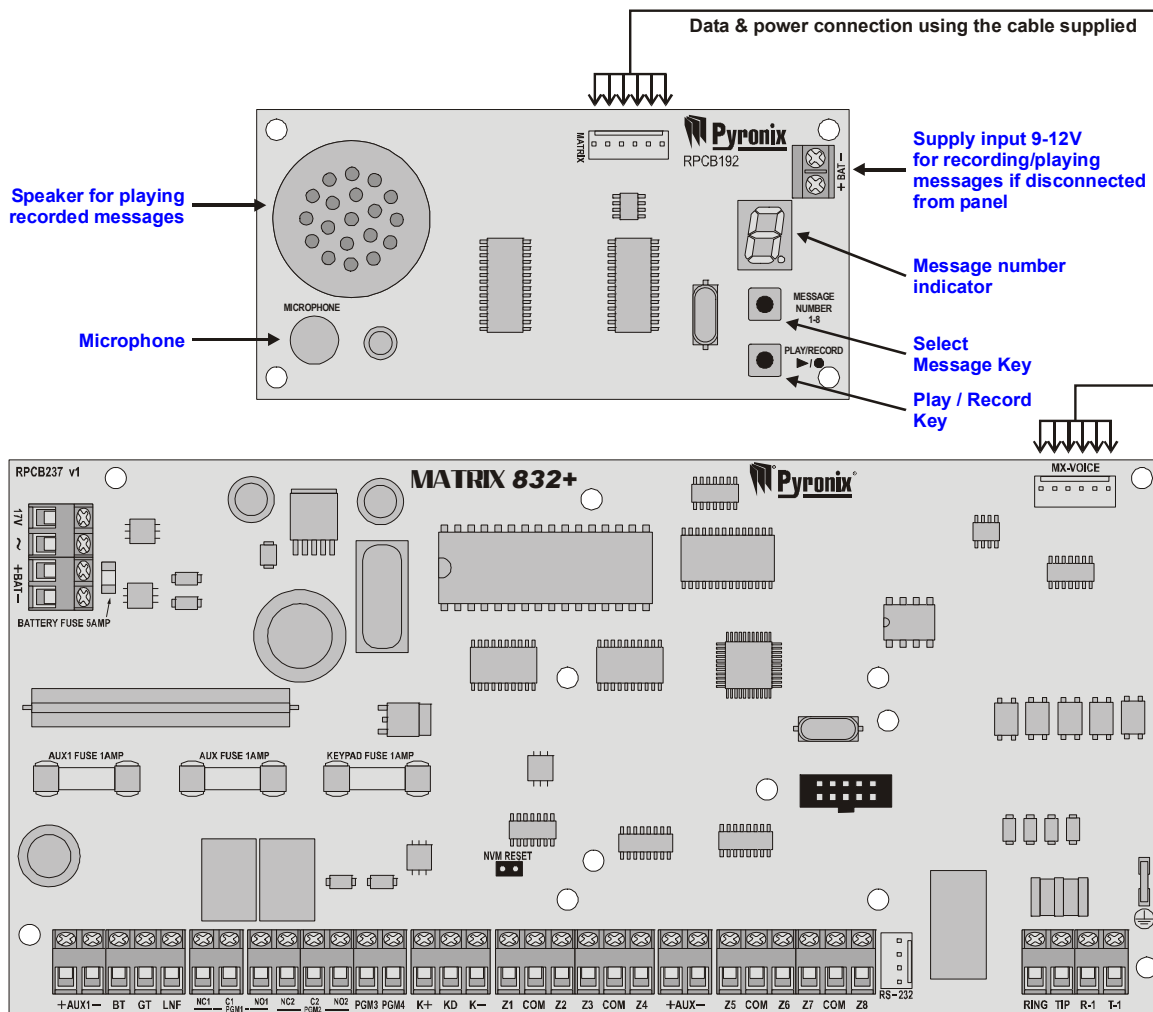

2.7.1 MX-VOICE Module Programming

Programming the MX-VOICE module consists of recording spoken messages (Voice message) via the onboard microphone. The number of a voice message should be selected before recording and the message may be played via the on-board speaker after recording. The MX-VOICE module can be programmed even if not connected to the panel. In this case, a 9-12V power supply must be connected between the «+BAT-» terminals.

PROGRAMMING

Initial state: MX-VOICE module should be connected to the panel or power supply unit.

Step 1 - SELECT VOICE MESSAGE NUMBER. Press the «MESSAGE NUMBER» key until the required number is reached (*1* ... *8* is displayed on the LED).

Step 2 - RECORDING. Press the «PLAY/RECORD» key (the voice message number starts flashing to indicate that recording has started) and hold it down while speaking into the on-board microphone. Release the «PLAY/RECORD» key after the message is finished. End of recording will be indicated as *F*. The maximum length of one message is 7 seconds.

Step 3 - PLAYING A VOICE MESSAGE. Choose the required voice message by pressing the «MESSAGE NUMBER» key (the message number is displayed on the LED), then press the «PLAY/RECORD» key once. The voice message will be played via the on-board speaker.

NOTE 1: Recorded messages are stored in the MX-VOICE module which was used for programming these messages only, and are not stored in the panel's NVM. NOTE 2: To enable the MX-VOICE module it is required to set the "Voice message" reporting format for the used telephone and allocate the number of voice messages for the event groups (Send Options).

2.8 Battery Monitor Board Wiring

The battery monitor board is a unique monitoring and test board for the Matrix range of control panels, including the Matrix 832, 832+, 424 and Matrix 6. Connect the battery monitor board to the control panel as illustrated below.

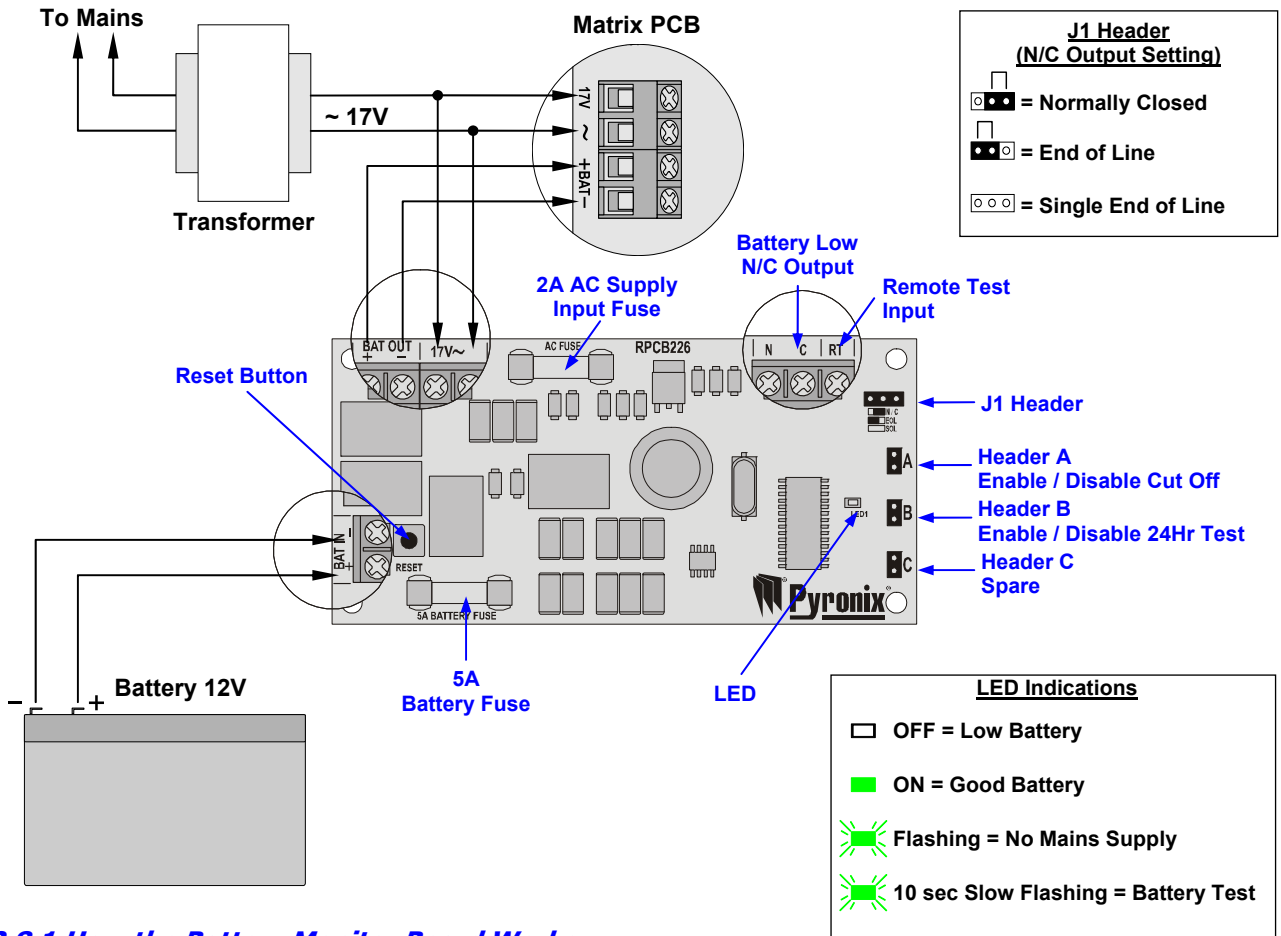

2.8.1 How the Battery Monitor Board Works

Once the mains supply is connected to the battery monitor board, it will continuously monitor the battery. If the battery supply is good, the LED on the battery monitor board will be illuminated. If there is no mains supply and the battery is low, the control system and battery monitoring board switch off, and the LED is no longer illuminated.

NOTE 1: When a new battery is fitted and there is no mains supply, the engineer should press the reset button to provide battery power to the board.

Battery Test

This option is disabled when the mains power is removed.

24 Hour Test Mode

24 Hour Test Mode is enabled by fitting header B. If enabled, and the battery voltage drops below 11.5 Volts, the battery supply is cut off from the Matrix for 5 seconds (enabled by fitting header A). A solid-state relay is turned on at the same time as the 5-second cut-off and gives an additional indication that the battery is low. This relay can be connected to the panel between outputs N/C and a zone input.

NOTE 2: If the zone connection is used, adjust header J1 to the relevant zone setting, i.e., Normally Closed, End Of Line or Single End Of Line. The zone setting of the battery monitoring board must be the same as that of the control panel.

RT.A low state on input RT can initiate a battery test.

2.9 Matrix Zone Expanders

2.9.1 Local Plug-On 8 Zone Expander MX-IX16

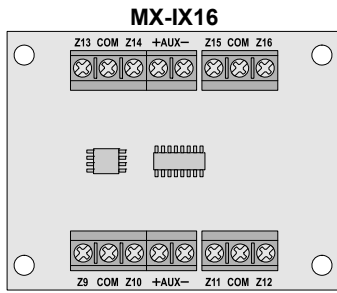

The MX-IX 16 should be connected to the Matrix PCB as shown below

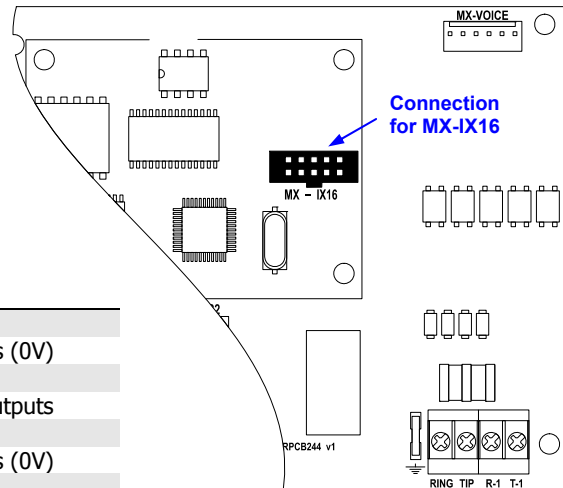
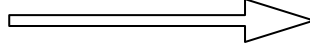

Z9	Zone 9 input	Z13	Zone 13 input
COM	Common for zones (0V)	COM	Common for zones (0V)
Z10	Zone 10 input	Z14	Zone 14 input
+AUX-	Auxiliary supply outputs	+AUX-	Auxiliary supply outputs
Z11	Zone 11 input	Z15	Zone 15 input
COM	Common for zones (0V)	COM	Common for zones (0V)
Z12	Zone 12 input	Z16	Zone 16 input

MATRIX 424

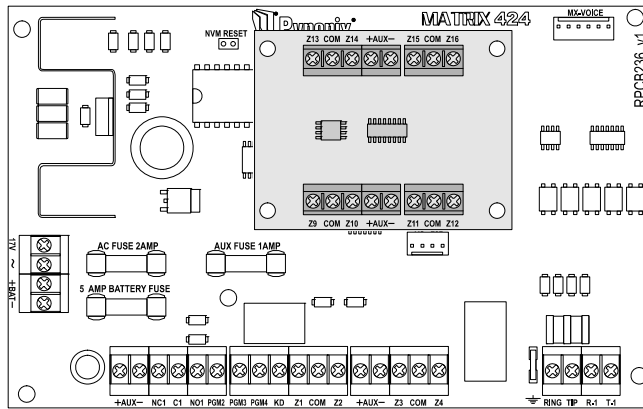

MATRIX 832

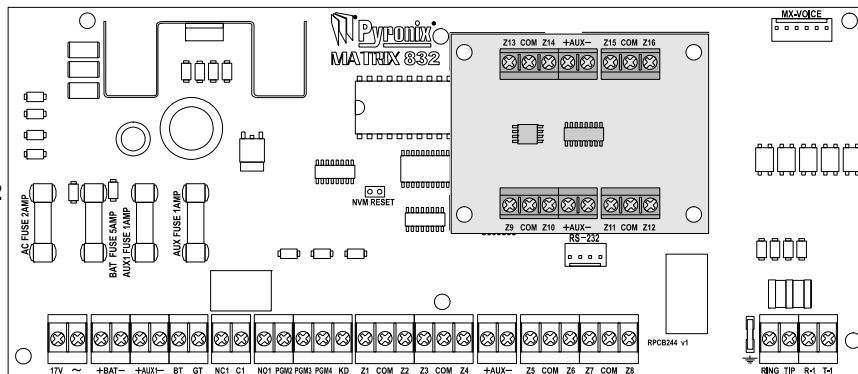

MATRIX 832+

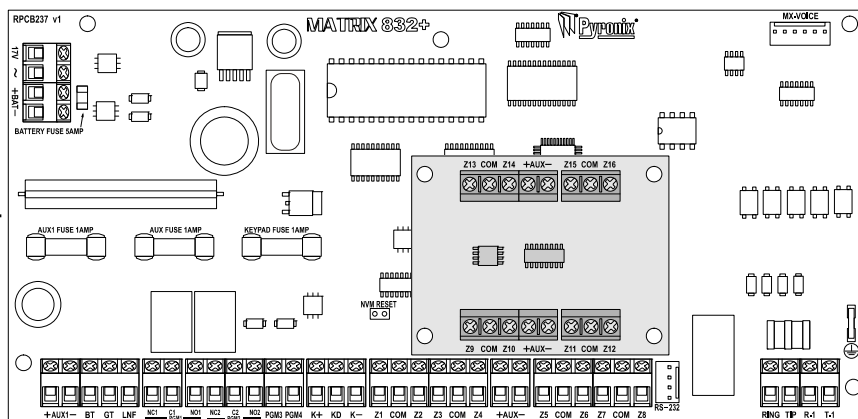

NOTE: After adding or removing equipment from the system, use engineers function 754 to scan for all devices on the Matrix bus.

2.9.2 Remote 8 Zone Expander MX-RIX with Zone Analyser

NOTE: When connecting RIX modules to the bus, you must make sure you do not exceed the maximum KEN number for the cable run. See Section 1.8 on page 3.

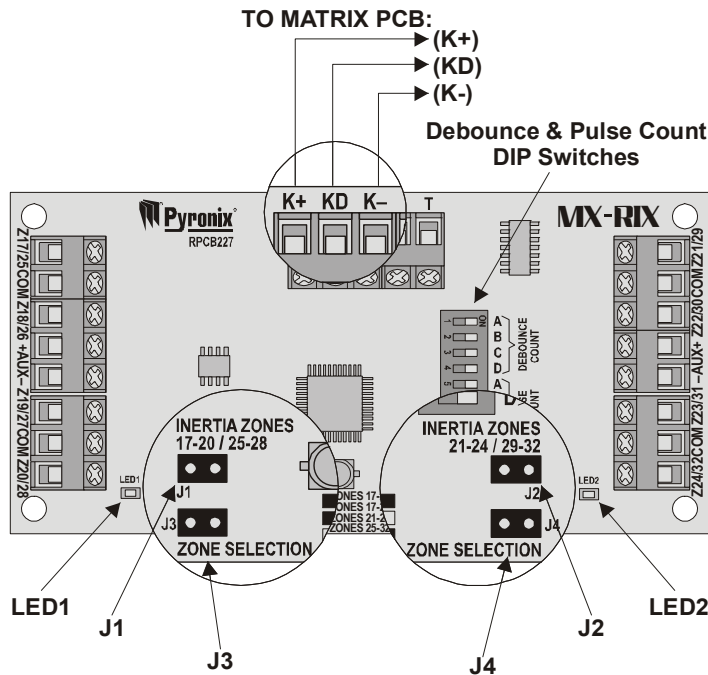

NOTE: Standard Mode – Zone Debounce of 300ms, Pulse Count 1
 Inertia Mode – See tables below

Jumpers

- J1** Inertia Select – Zones 17 – 20 (25 – 28) – Jumper on selects inertia mode.
- J2** Inertia Select – Zones 21 – 24 (29 – 32) – Jumper on selects inertia mode.
- J3** Zone Select
- J4** Zone Select

NOTE: Jumpers J3 and J4 must either be BOTH on or BOTH off. Both on addresses the expander as the lower expander (zones 17 – 24). Both off addresses the expander as the upper one (zones 25 – 32).

LED Indications

LED	Indication
	Zones are enabled in Standard Mode
	No Communication
	Zones are enabled in Inertia Mode
 = ON, = SLOW FLASH, = FAST FLASH	

NOTE 1: It is not possible to connect two 4-zone RIXs that have the SAME 4 zones enabled (one RIX MUST be zones 17 - 20, the other MUST be zones 21 - 24).

When connected, initiate scan for devices on the bus by entering **▲ 7 5 4**.

When changing between on-board and remote expanders on an already installed system, you should remove all the expanders, scan for devices, and then add the expander and perform another scan. This way the Matrix panel will correctly detect the expander.

NOTE 2: During local up / down loading periods the Matrix panel will stop communications with the remote zone expander, and LEDs 1 and 2 will flash.

Debounce and Pulse Count Settings

The MX-RIX input expander has been designed to enable sensitivity adjustment of “de-bounce & pulse count switches” for shock sensors that are designed to detect sharp vibrations.

Low sensitivity - use in a noisy environment, e.g. near roads, airports or factories.

High sensitivity - use in a quiet environment.

In inertia mode the two settings are pulse and debounce count, which can be used in combination to give a sensitivity adjustment.

The pulse count can be adjusted from default of one pulse count to 16. This means that if a number of pulses occur within a period of one second the zone will be activated. This occurs even if the debounce period has not been exceeded.

The debounce count gives a coarse adjustment so that the expander will only give an alarm on a stronger impact. The debounce period can be adjusted from the default of one debounce period to a debounce period of 16. This means that if a debounce period has been exceeded then the zone will be activated.

DEBOUNCE SETTING

	Zone Sensitivity, ms																
	High	4	8	12	16	20	24	28	32	36	40	44	48	52	56	60	Low
A	OFF	ON	OFF	ON	OFF	ON	OFF	ON	OFF	ON	OFF	ON	OFF	ON	OFF	ON	ON
B	OFF	OFF	ON	ON	OFF	OFF	ON	ON	OFF	OFF	ON	ON	OFF	OFF	ON	ON	ON
C	OFF	OFF	OFF	OFF	ON	ON	ON	ON	OFF	OFF	OFF	OFF	ON	ON	ON	ON	ON
D	OFF	OFF	OFF	OFF	OFF	OFF	OFF	OFF	OFF	ON	ON	ON	ON	ON	ON	ON	ON



OFF ←

PULSE COUNT SETTING

	Pulse Count																
	High	1	2	3	4	5	6	7	8	9	10	11	12	13	14	15	Low
A	OFF	ON	OFF	ON	OFF	ON	OFF	ON	OFF	ON	OFF	ON	OFF	ON	OFF	ON	ON
B	OFF	OFF	ON	ON	OFF	OFF	ON	ON	OFF	OFF	ON	ON	OFF	OFF	ON	ON	ON
C	OFF	OFF	OFF	OFF	ON	ON	ON	ON	OFF	OFF	OFF	OFF	ON	ON	ON	ON	ON
D	OFF	OFF	OFF	OFF	OFF	OFF	OFF	OFF	OFF	ON	ON	ON	ON	ON	ON	ON	ON

NOTE: When in inertia mode, zones can only be set to Normally Closed.

2.9.3 Wiring 28 Zones to Matrix 424

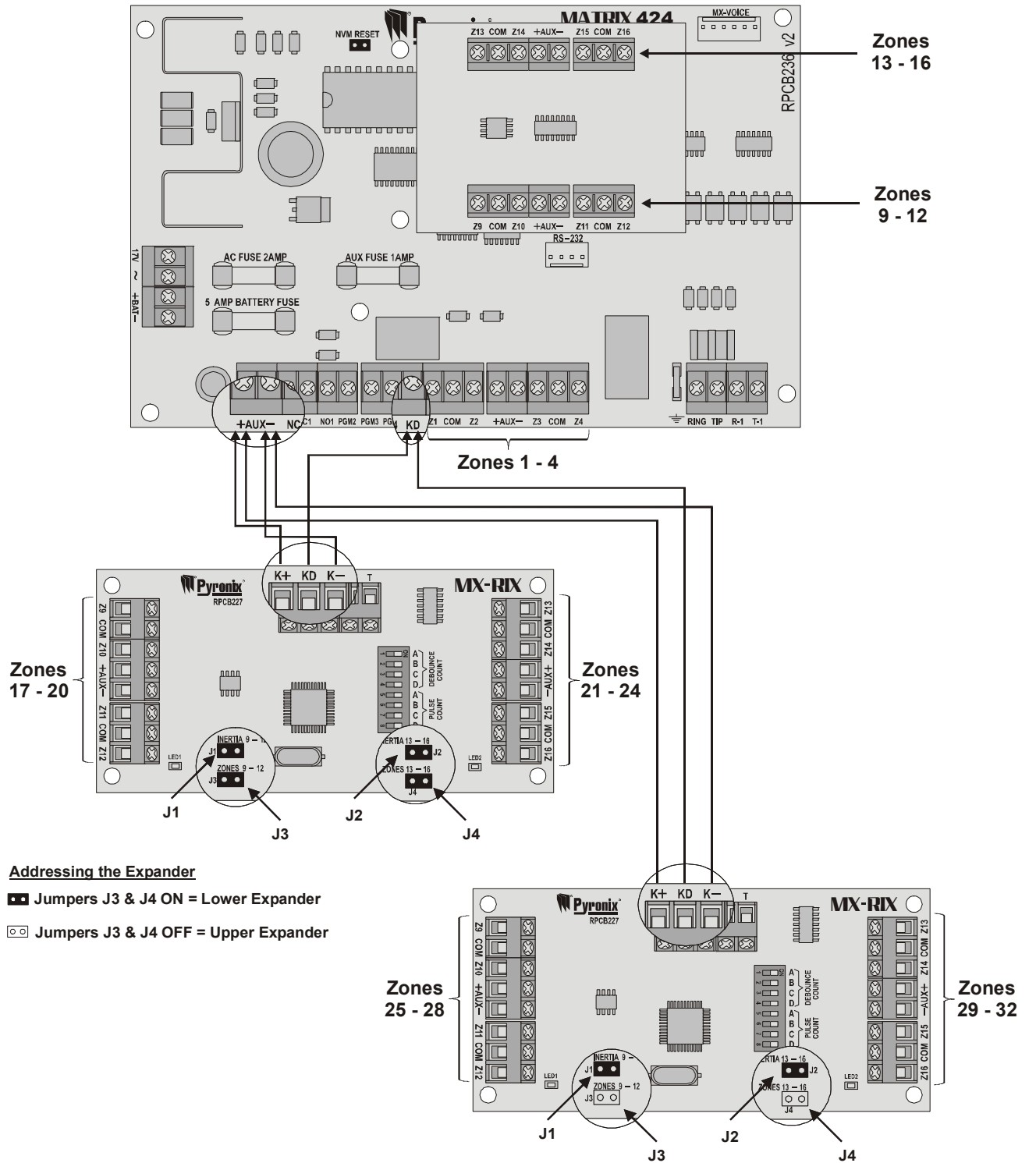

2.9.4 Wiring 32 Zones to Matrix 832

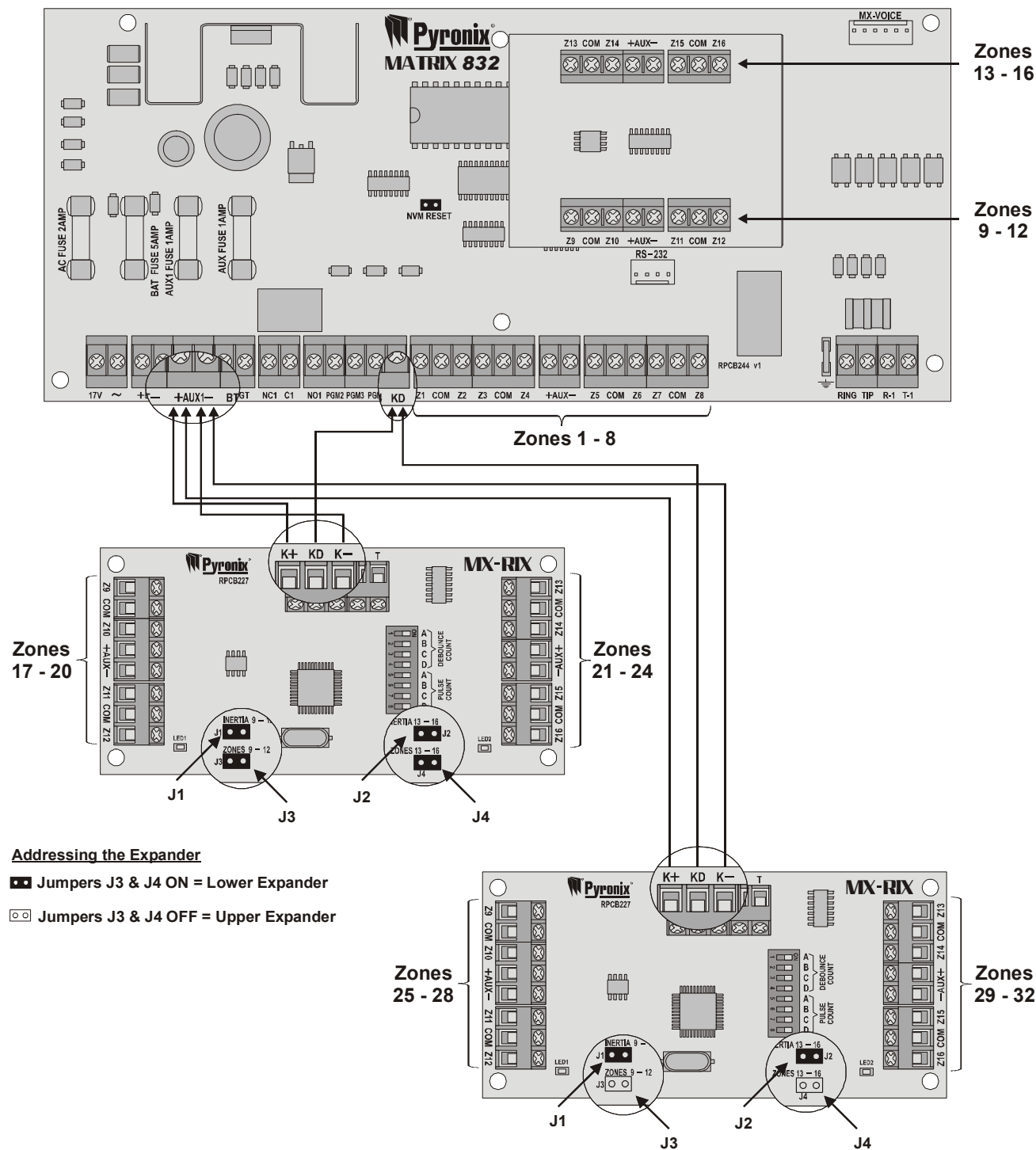

2.9.5 Wiring 32 True Zones to Matrix 832+

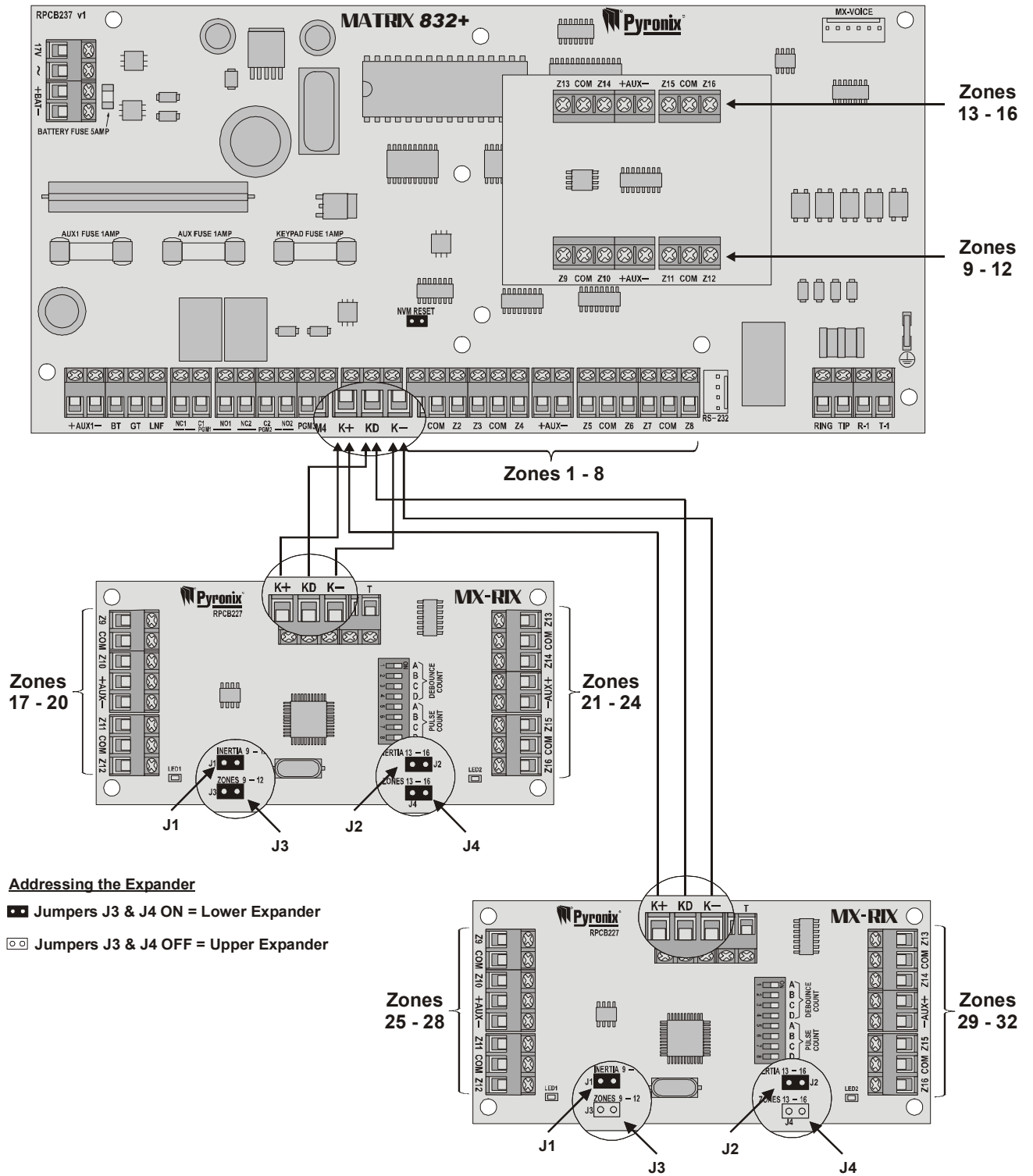

2.10 Matrix PGM Expanders

The ROX8R/8T is an additional feature to the Matrix panel, which will enable all 12 programmable outputs on the matrix panel to be used. See cabling restrictions in Section 1.8 for the KEN values, which may be used with the output expander.

2.10.1 Transistor Output Expander MX-ROX8T

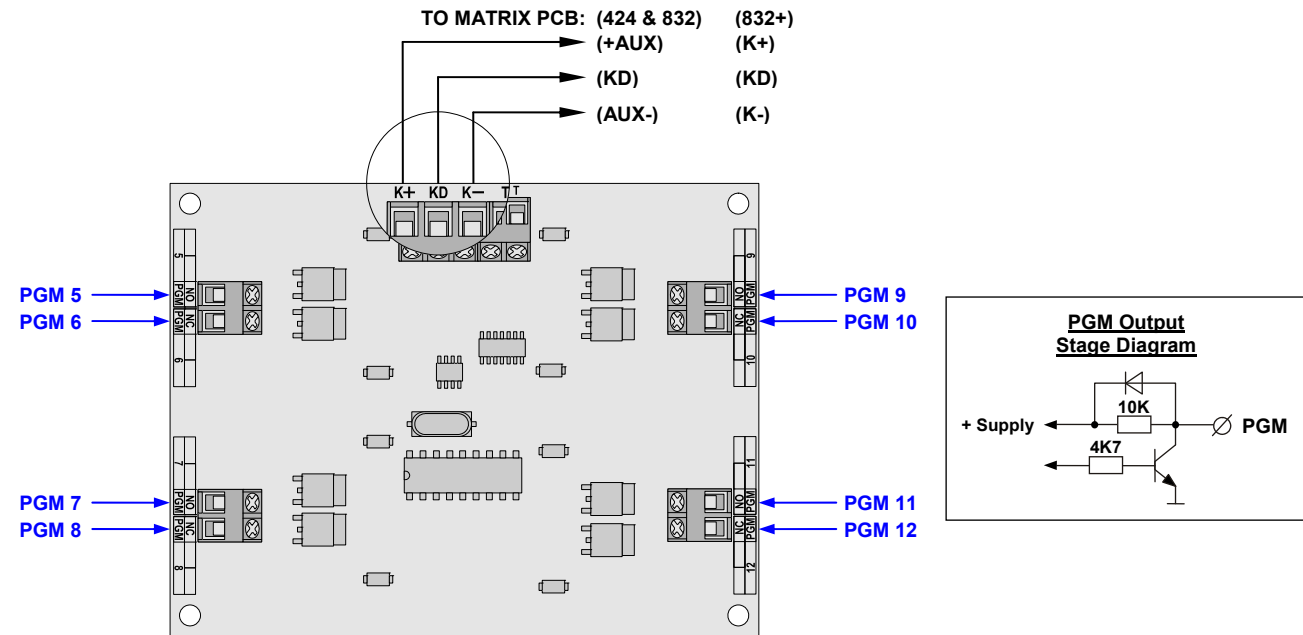

2.10.2 Relay Output Expander MX-ROX8R

NOTE: The relay output expander provides voltage free change over contacts. This is more flexible and can isolate the circuit from the system.

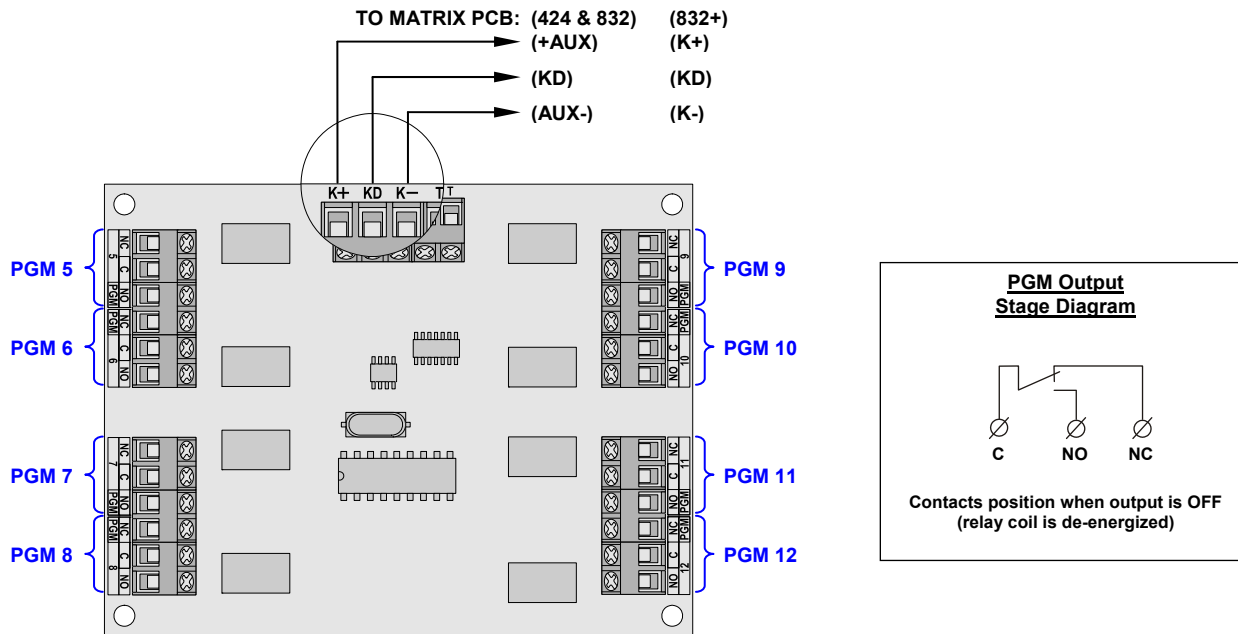

NOTE: After adding or removing equipment from the system, use engineers function 754 to scan for all devices on the Matrix bus.

2.11 Matrix Wireless Expanders

NOTE: When connecting RIX modules to the bus, you must make sure you do not exceed the maximum KEN number for the cable run. See Section 1.8 on page 3.

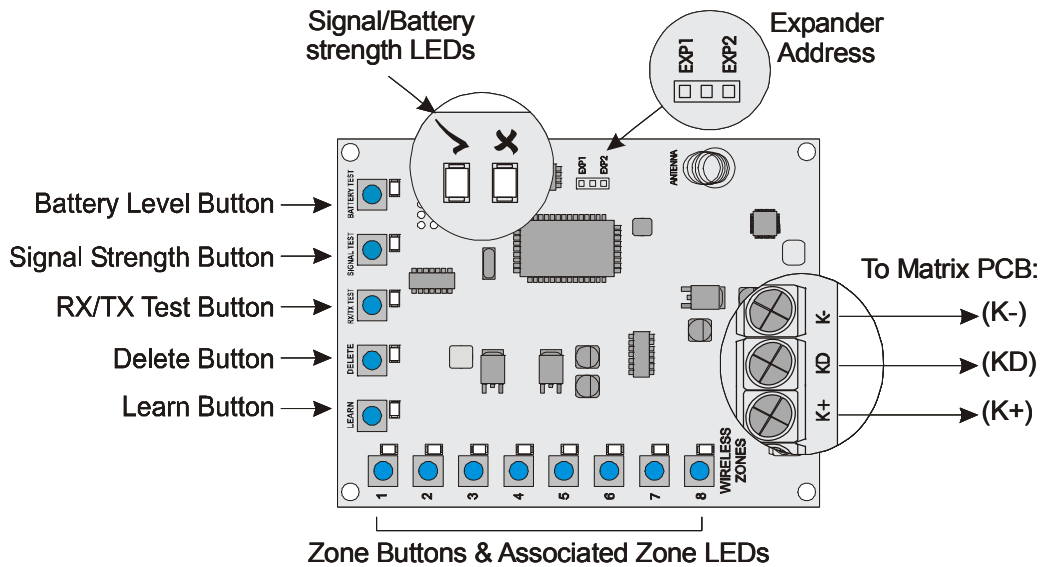

Signal/Battery Strength LEDs

The signal strength LEDs show two states, the signal strength and the battery levels of each zones. The table below shows the different states.

Testing Signal Strengths:	Testing Battery Levels:
<u>LEDS</u>	<u>LEDS</u>
GREEN ✓ = Signal Strength GOOD	GREEN ✓ = Battery Level GOOD
RED ✘ = Singal Strength BAD	RED ✘ = Battery Level BAD

Zone Addressing

It is possible to have up to two wireless expanders on any one Matrix Wireless System. If two expanders are installed on a single Matrix wireless system, they need to be different IDs. One expander should be set to EXP1 and the other should be set to EXP2.

Setting to EXP1 maps the 8 wireless expander onto <i>Zones 17-24</i> on the Matrix alarm panel.	<input checked="" type="checkbox"/> EXP1 <input type="checkbox"/> EXP2
Setting to EXP2 maps the 8 wireless expander onto <i>Zones 25-32</i> on the Matrix alarm panel.	<input type="checkbox"/> EXP1 <input checked="" type="checkbox"/> EXP2

2.11.1 Wiring 32 true zones with the wireless expander to a Matrix.

The below example shows how to connect 2 x MX-RIX8DW to a Matrix 832+, please note the same principle is used for the Matrix 424 and 832, however, on the Matrix 424 you can have a maximum of 28 zones only.

Please note you do not have to use 32 zones

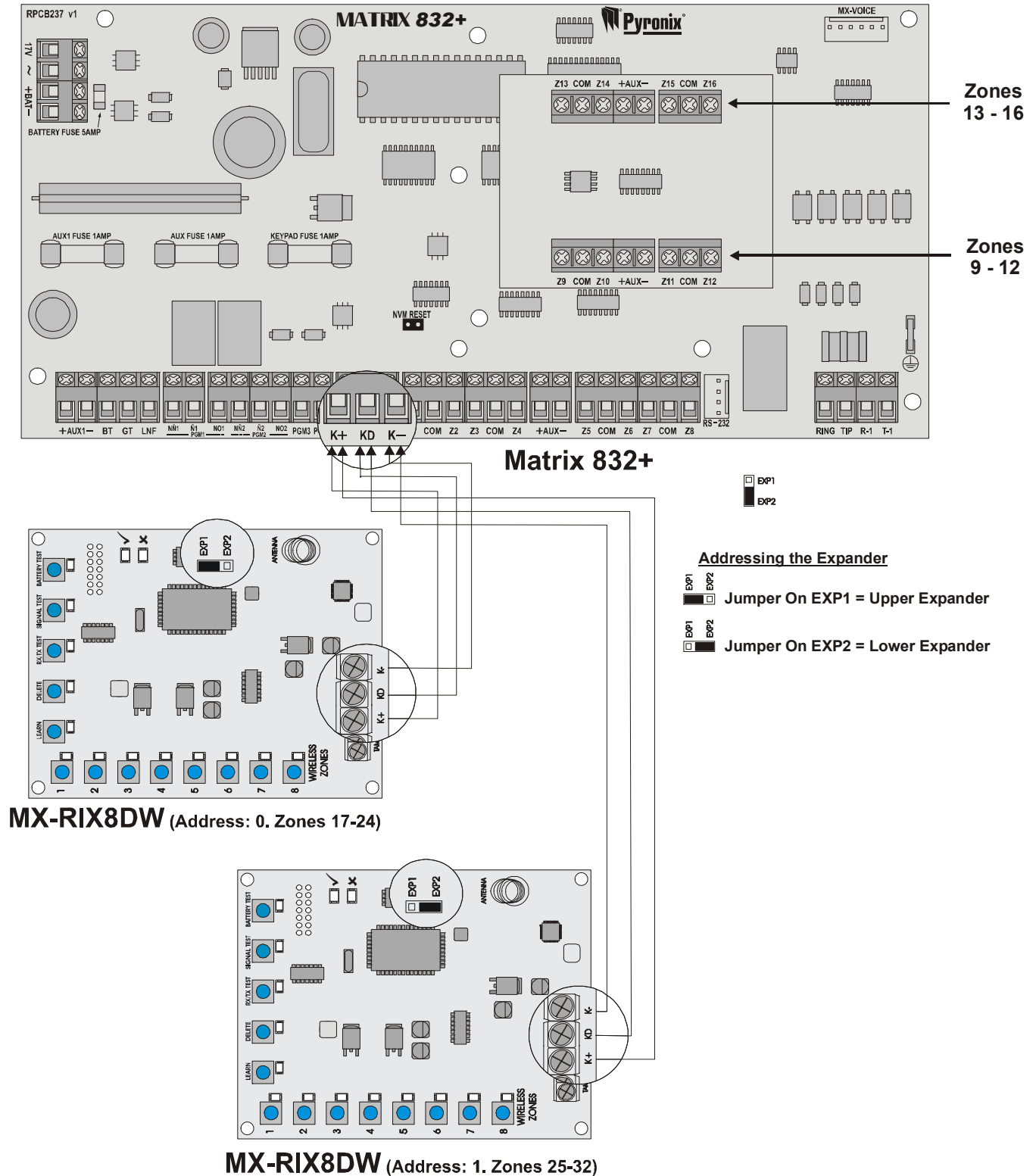

2.12 Zone Wiring

2.12.1 Normally Closed Zones Connection to Matrix 424

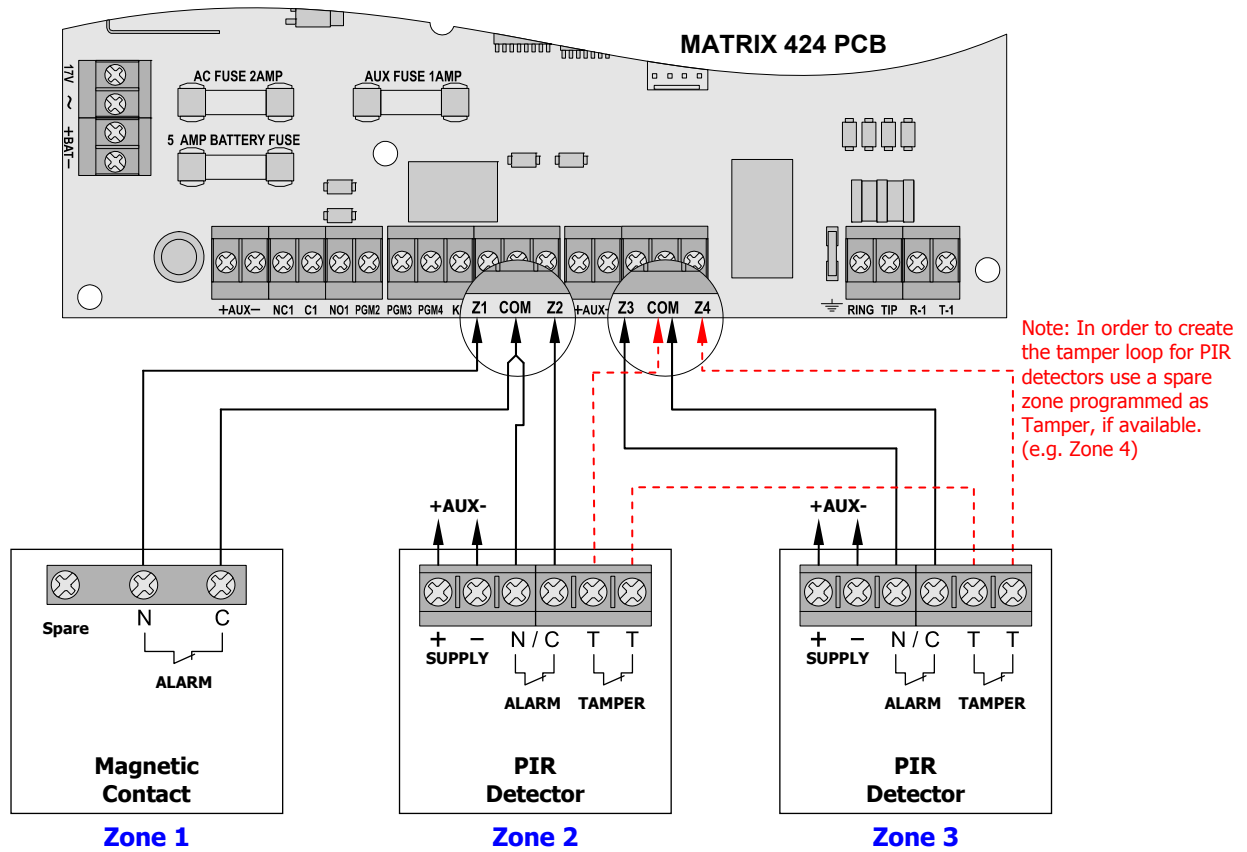

2.12.2 Normally Closed Zones Connection to Matrix 832 (832+)

NOTE: Terminal connections to Matrix 832+ are the same as to a Matrix 832.

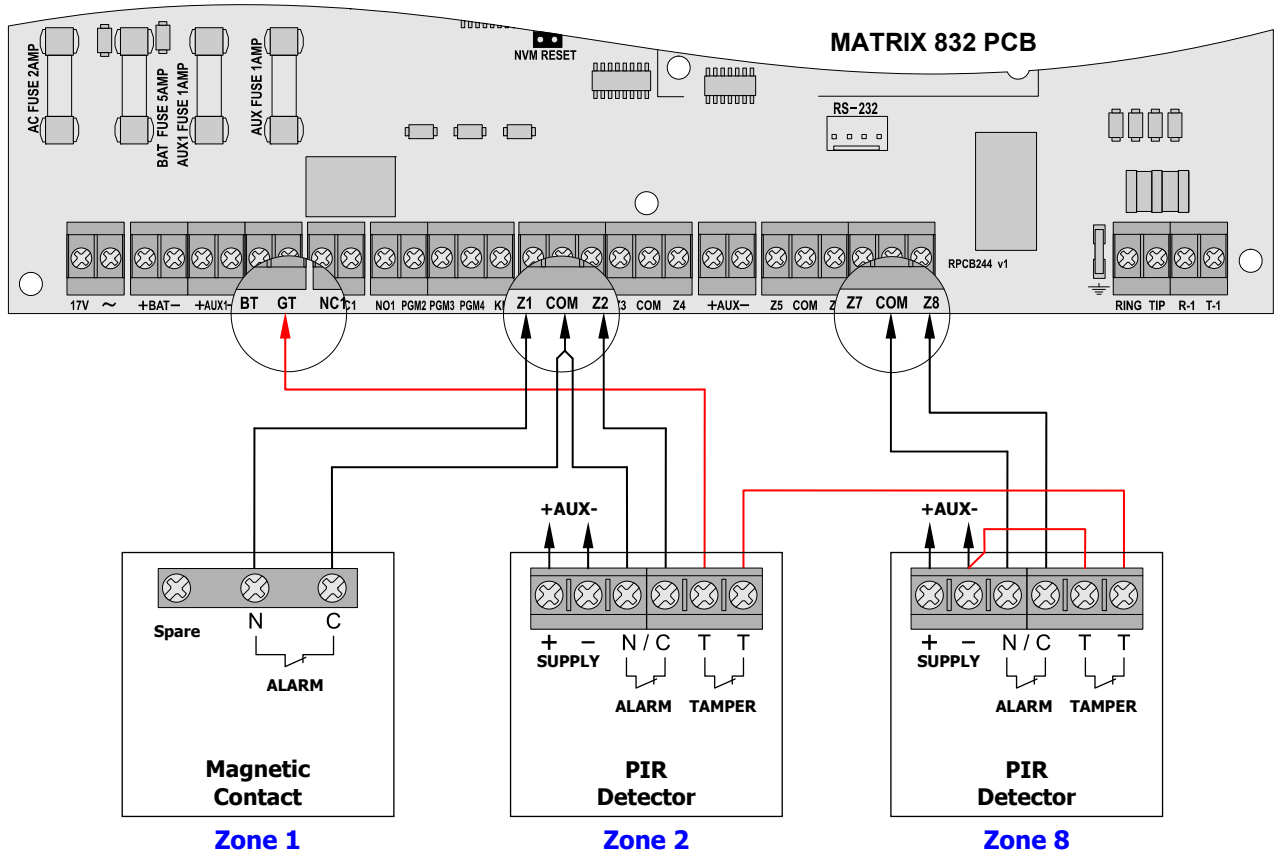

2.12.3 Single End of Line Zones (Alarm zones – no tamper) Connection to Matrix

NOTE 1: Terminal connections to Matrix 424 and 832+ are the same as to a Matrix 832.

Please note that this wiring configuration can only be used when Option 5 in Global Zone Options (Function 250) is turned enabled.

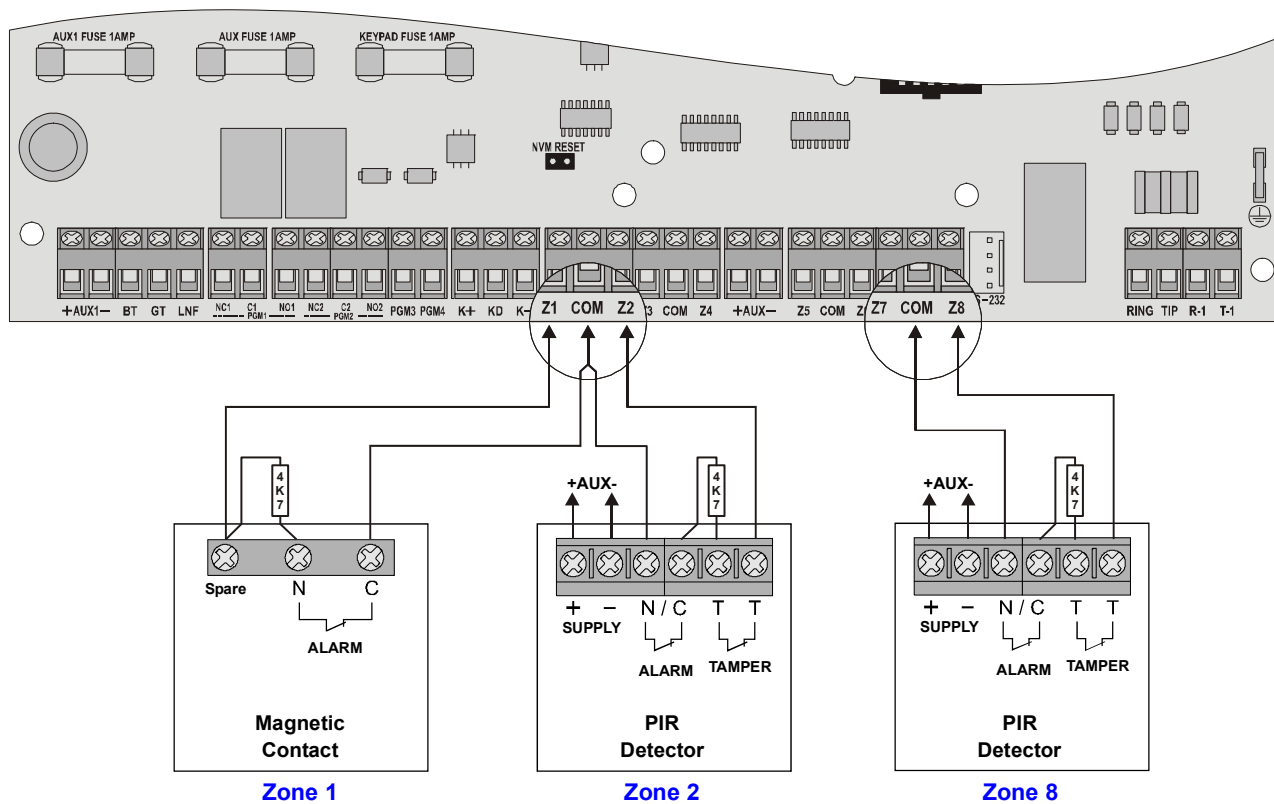

2.12.4 Double End of Line Zones Connection to Matrix

NOTE 1: Terminal connections to Matrix 424 and 832+ are the same as to a Matrix 832.

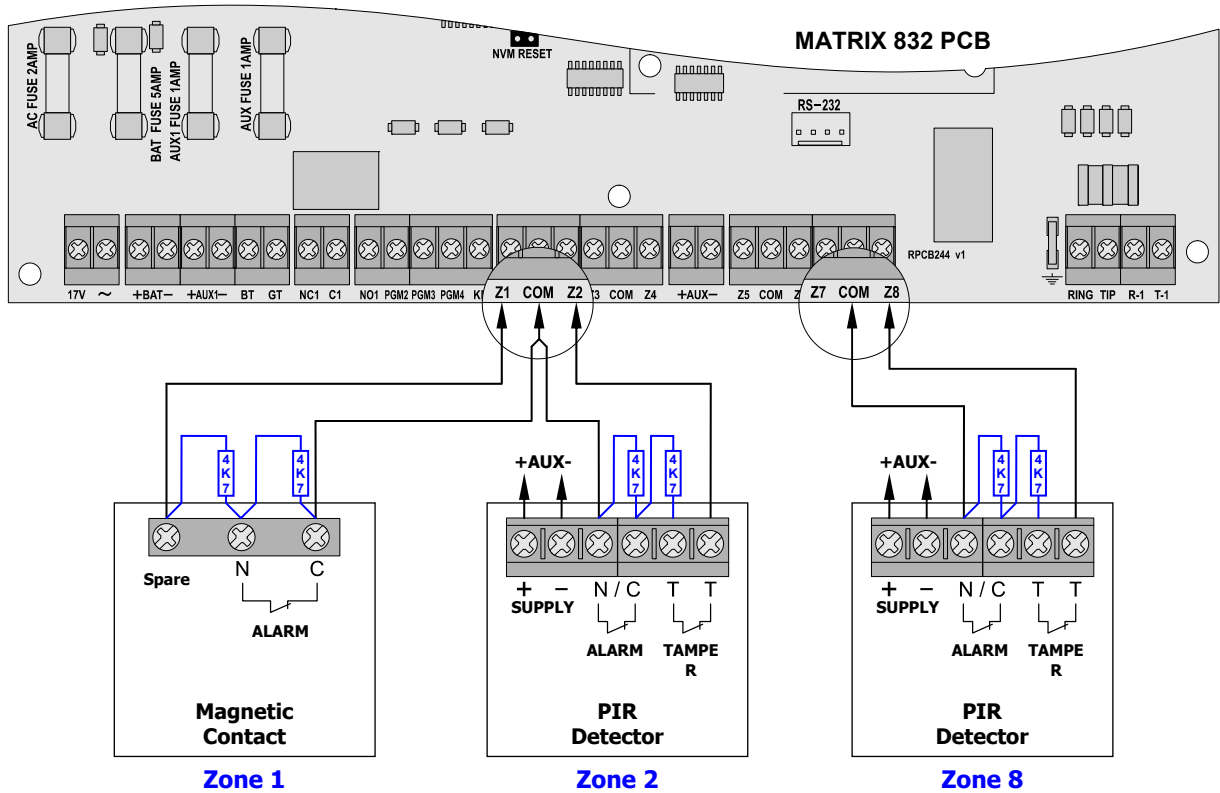

Connection of several detectors to one zone

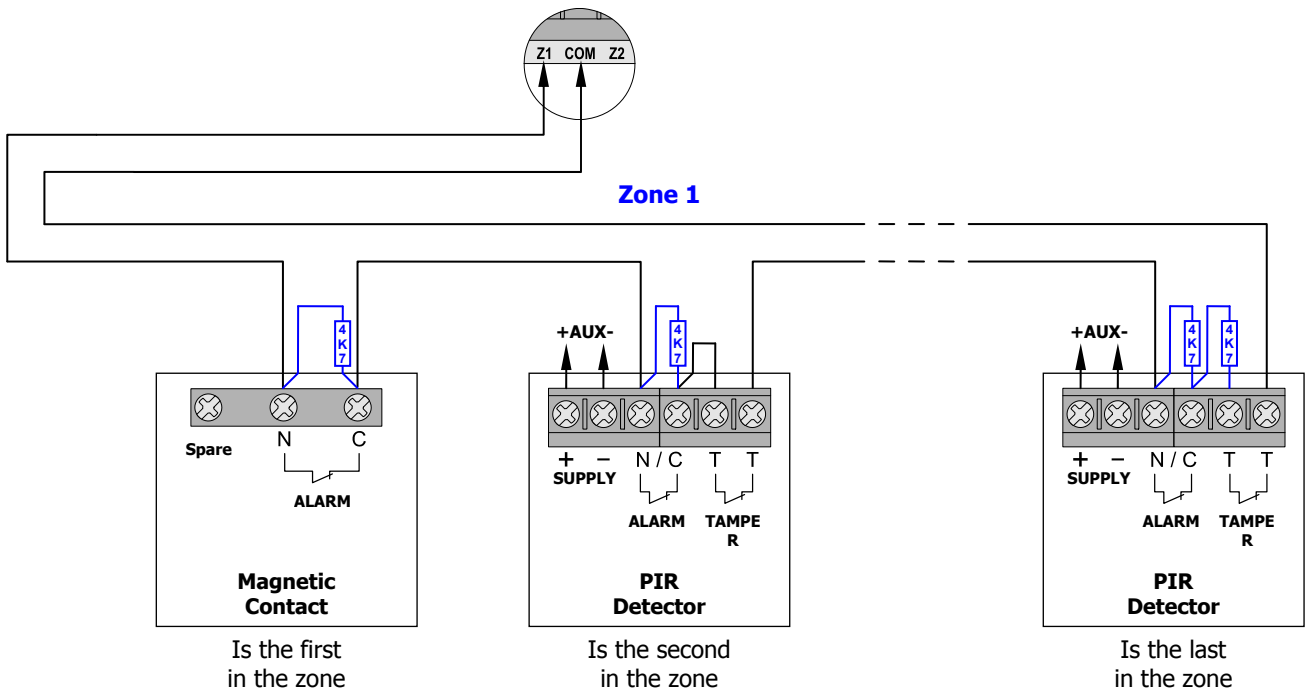

NOTE 2: The wiring shown at the bottom of the diagram allows 24 hour tamper monitoring of all detectors in one zone and of the zone circuit, with retaining the two-wire loop. It is not recommended to connect more than 6 detectors in this way (not more than 7 x 4K7Ω±5% resistors). More than 6 detectors may be connected to one zone in this way only if simultaneous activation of six or more detectors is improbable (in disarmed mode also), otherwise it will cause a tamper alarm.

2.12.5 Zone Doubling to Matrix

NOTE: Up to 64 zones can be programmed when using Zone Doubling on MX 832/832+

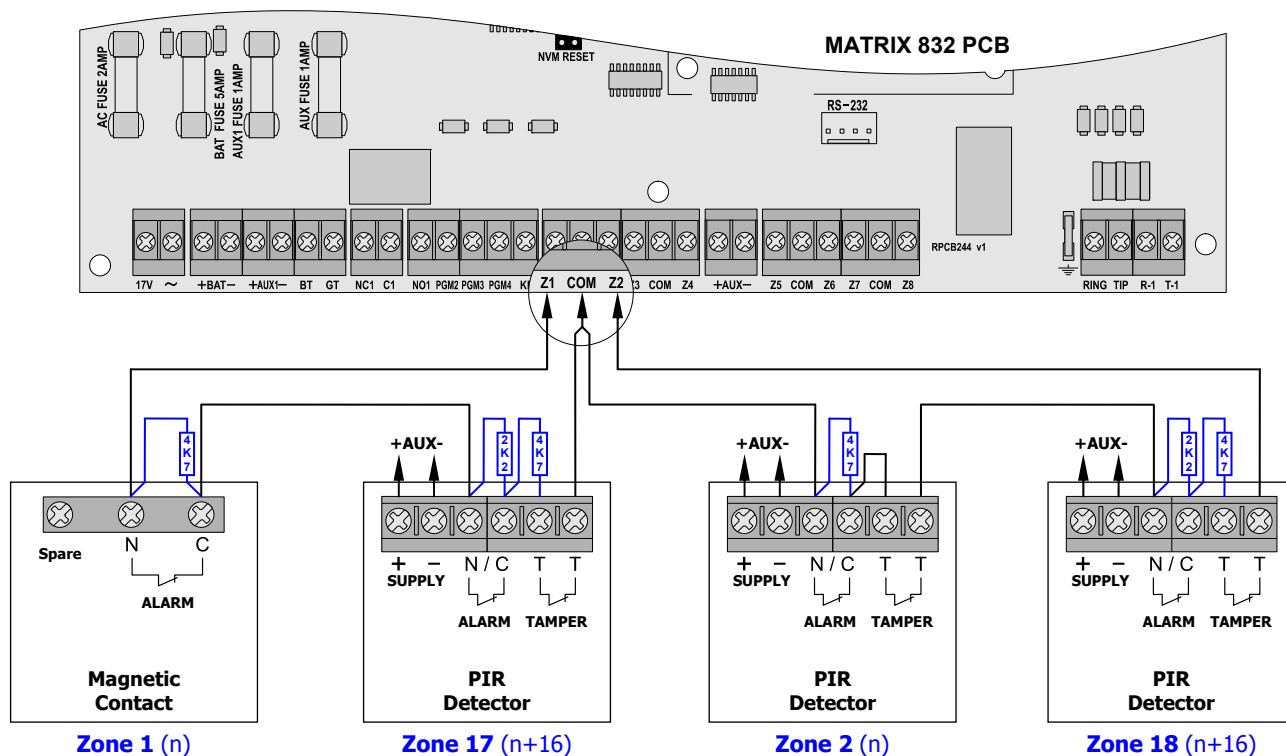

Connection of several detectors to one zone

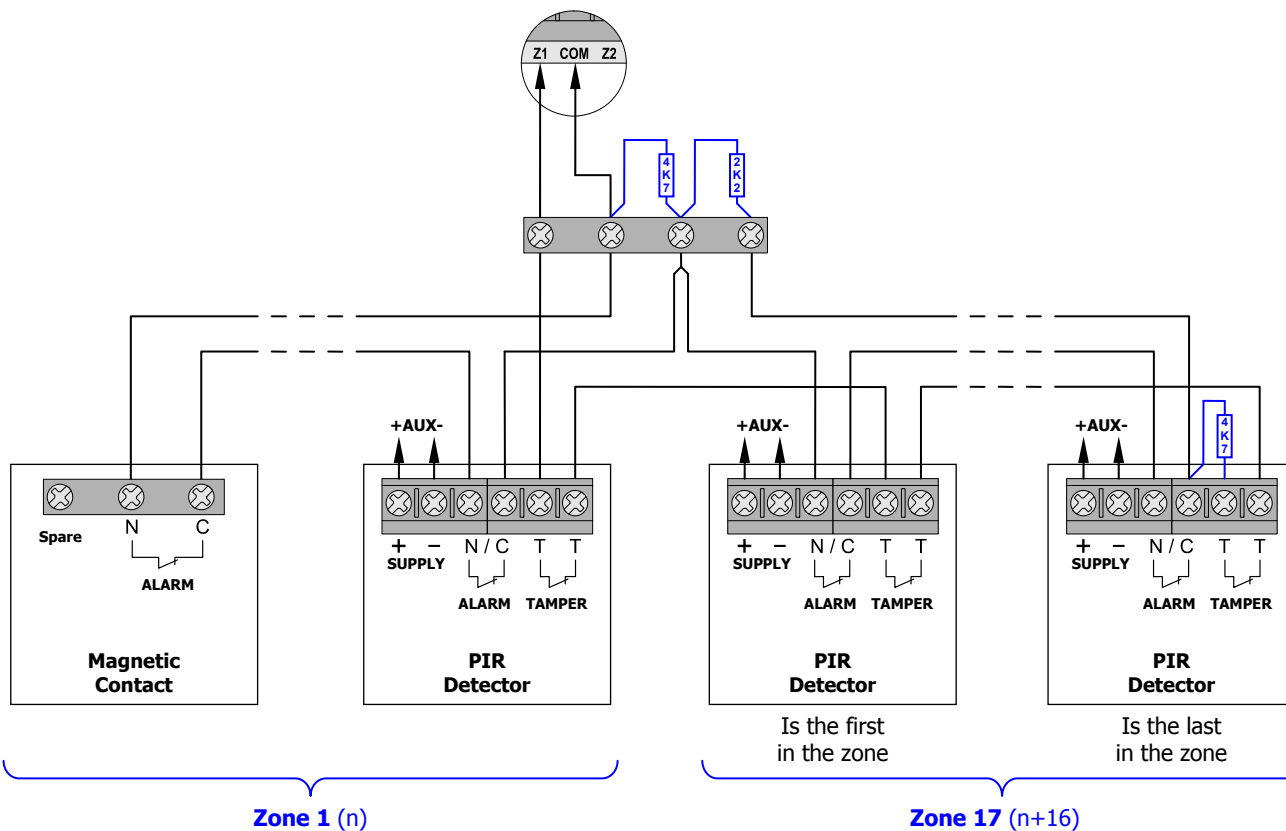

The Zone Doubling Map:

Control Panel: Zones 1-8 / Zones 17-24

Plug On Expander: Zones 9-16 / Zones 25-32

RIX1: Zones 33-40 / Zones 49-56

RIX2: Zones 41-48 / Zones 57-64

2.13 Programmable Outputs Wiring

2.13.1 External Sounder Connection to Matrix 424

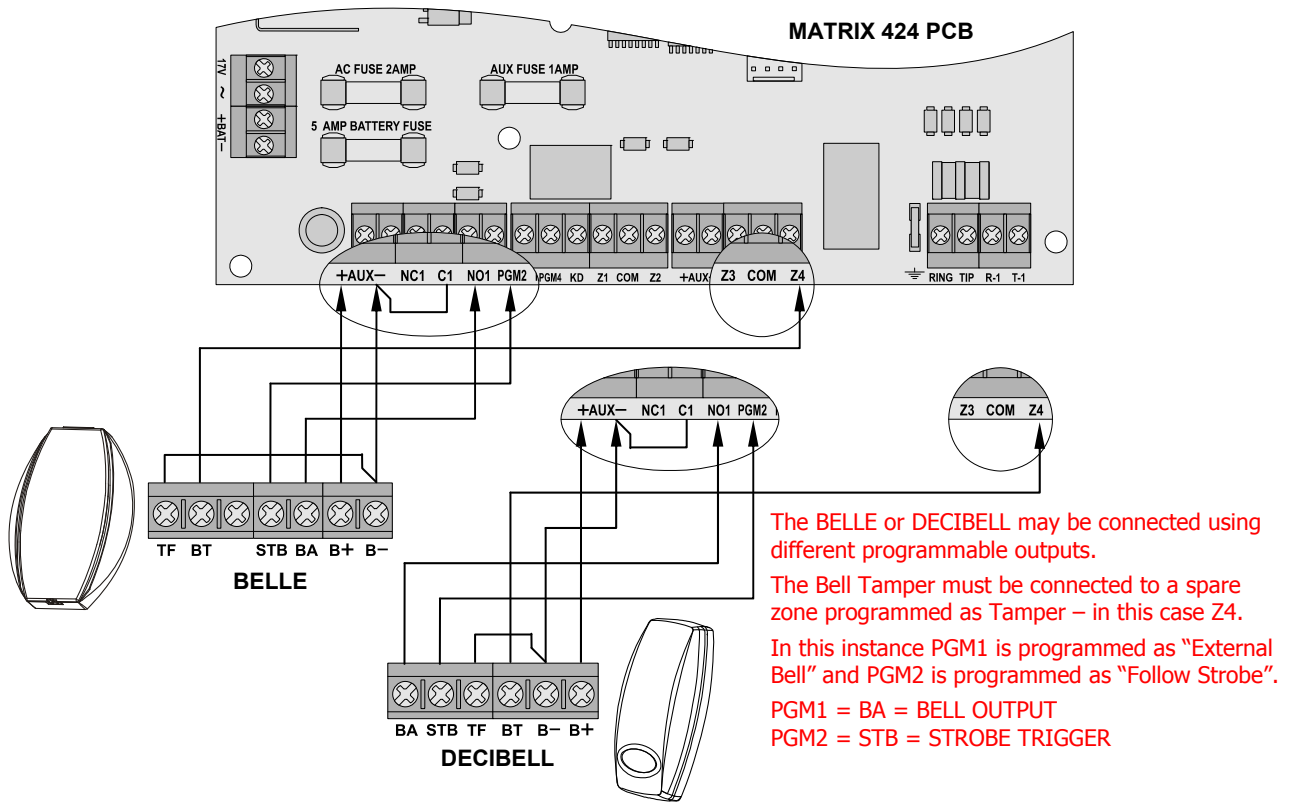

2.13.2 External Sounder Connection to Matrix 832

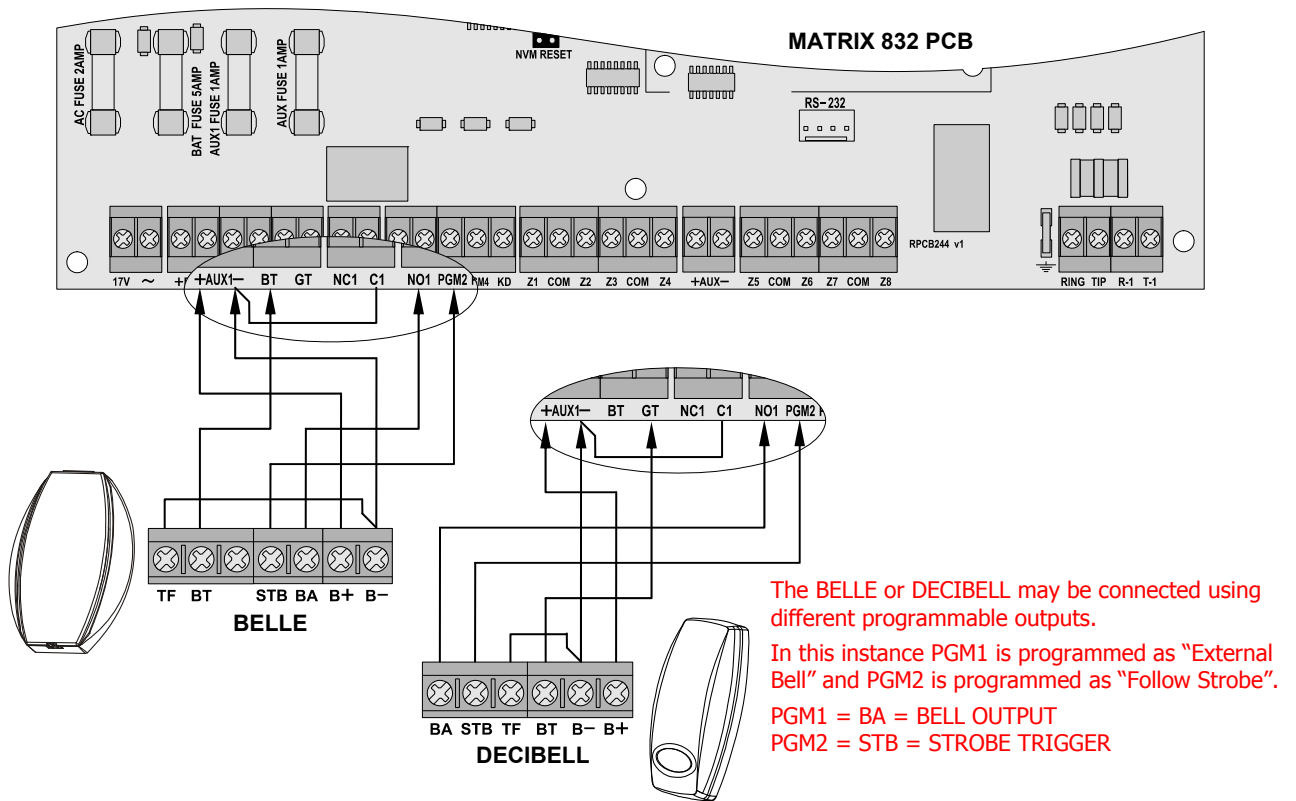

2.13.3 External Sounder Connection to Matrix 832+

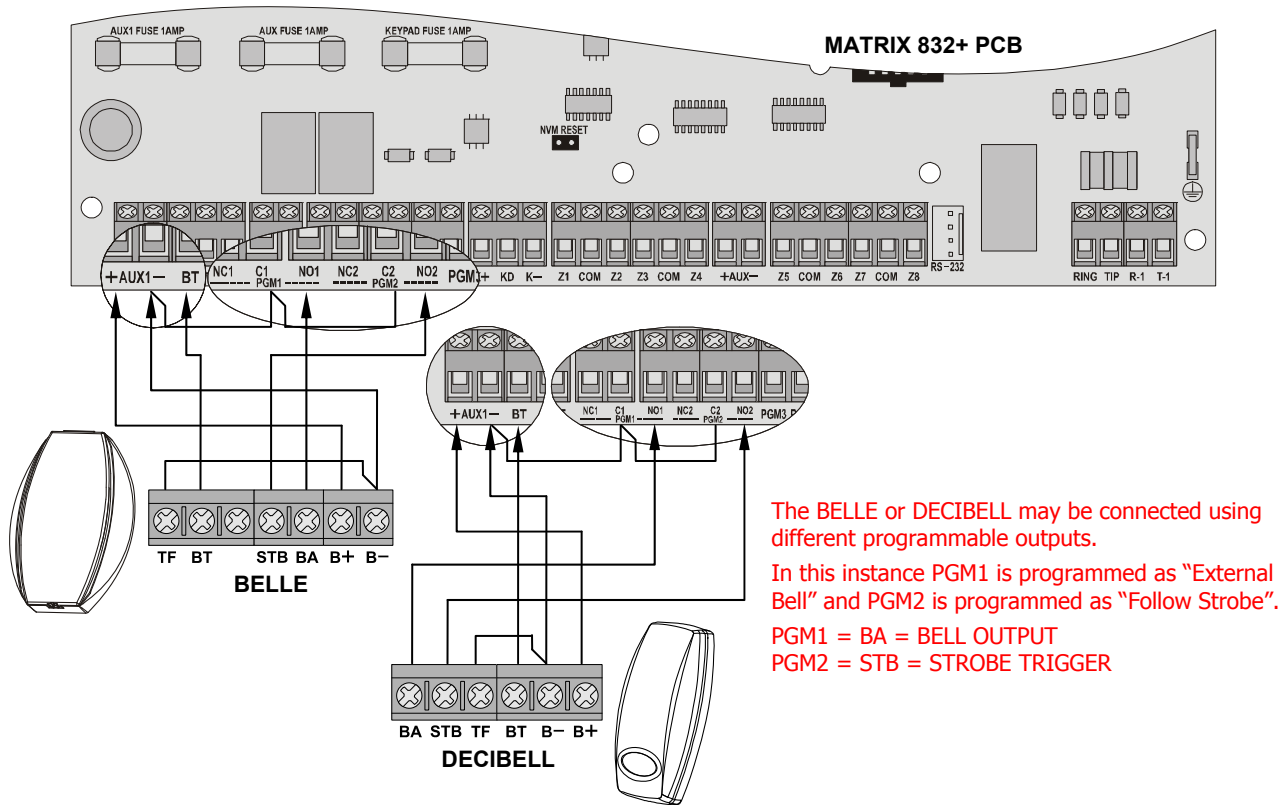

2.13.4 TWIN ALERT Internal Sounder Connection to Matrix 424

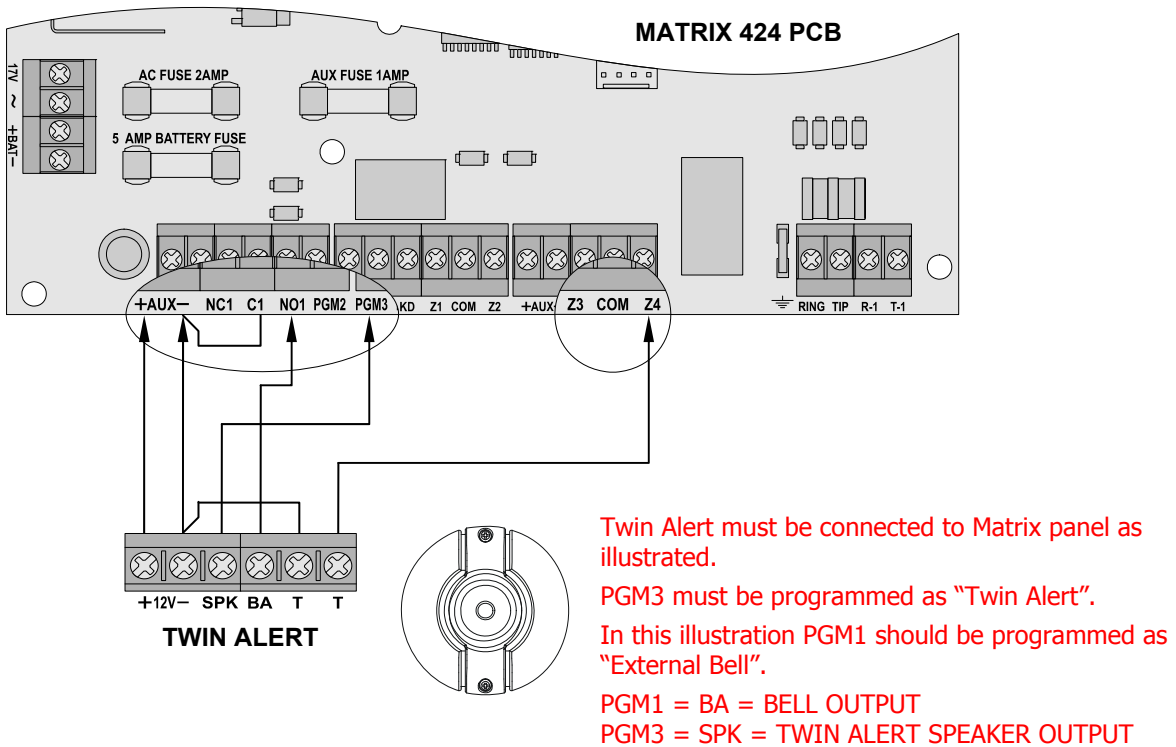

2.13.5 TWIN ALERT Internal Sounder Connection to Matrix 832 (832+)

NOTE: Terminal connections to Matrix 832+ are the same as to a Matrix 832.

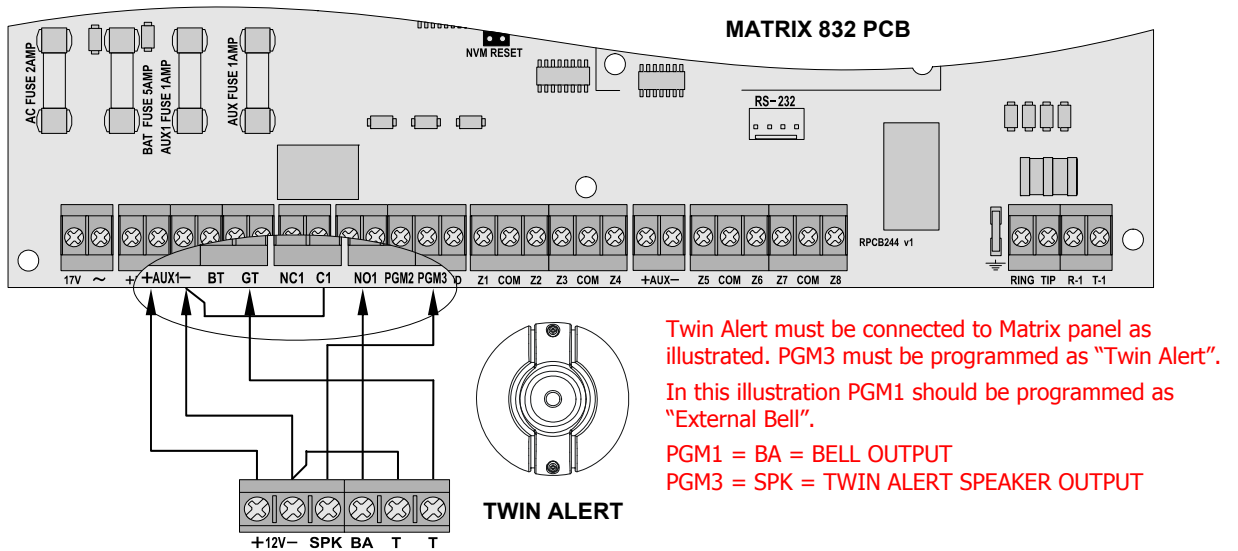

2.13.6 Buzzer, LED & Any Siren Connection to Matrix

NOTE: Terminal connections to Matrix 424 and 832+ are the same as to a Matrix 832.

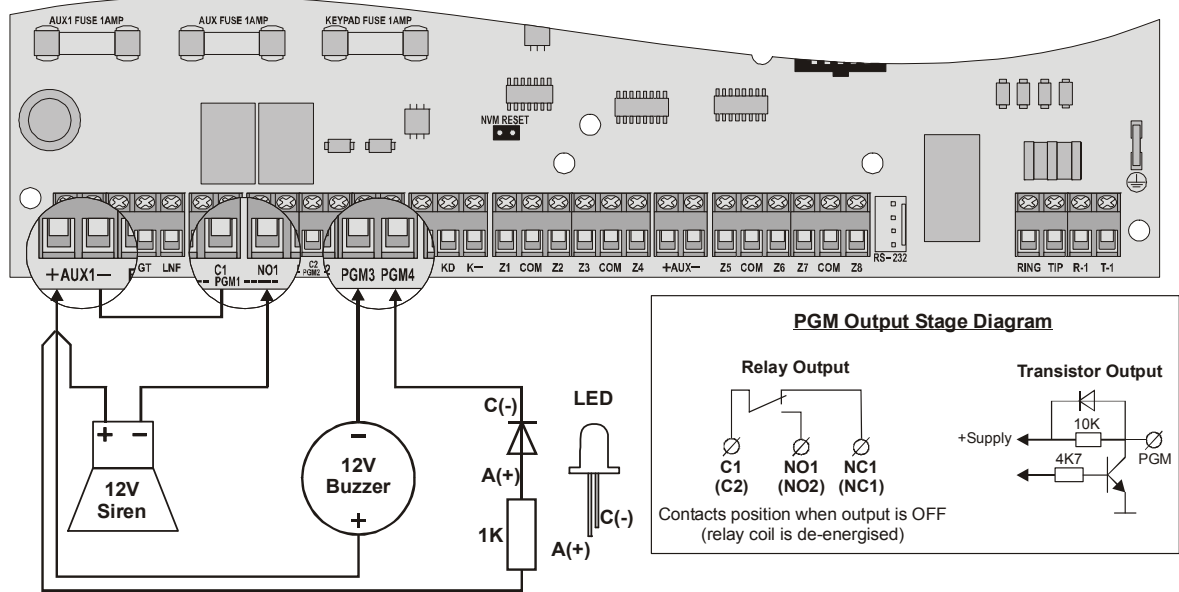

NOTE 1: Buzzer 12V@200mA may be connected to any of the programmable outputs, except PGM 4. Siren 12V@500mA must be connected to relay PGM output. LED may be connected to any of the programmable outputs.

NOTE 2: When a high power siren is to be connected to the Matrix, PGM1 should be used. This output uses a relay to switch up to a maximum 3A DC current capacity, allowing the use of an additional battery to power the siren as shown in the diagram below.

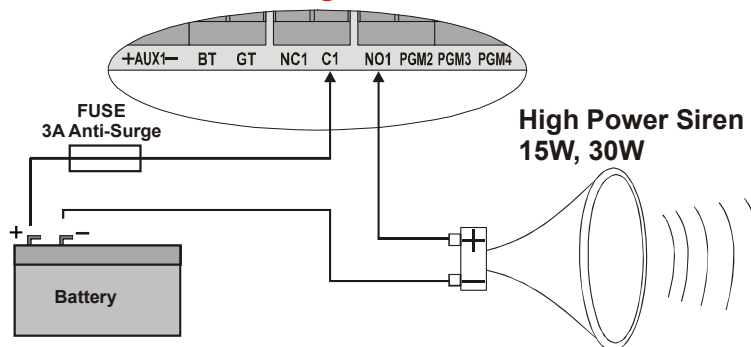

2.13.7 Vocaliser Connection to Matrix 832 (424)

NOTE: Terminal Connections to Matrix 424 are the same as to a Matrix 832, except that the tamper is connected to a zone programmed as "Tamper".

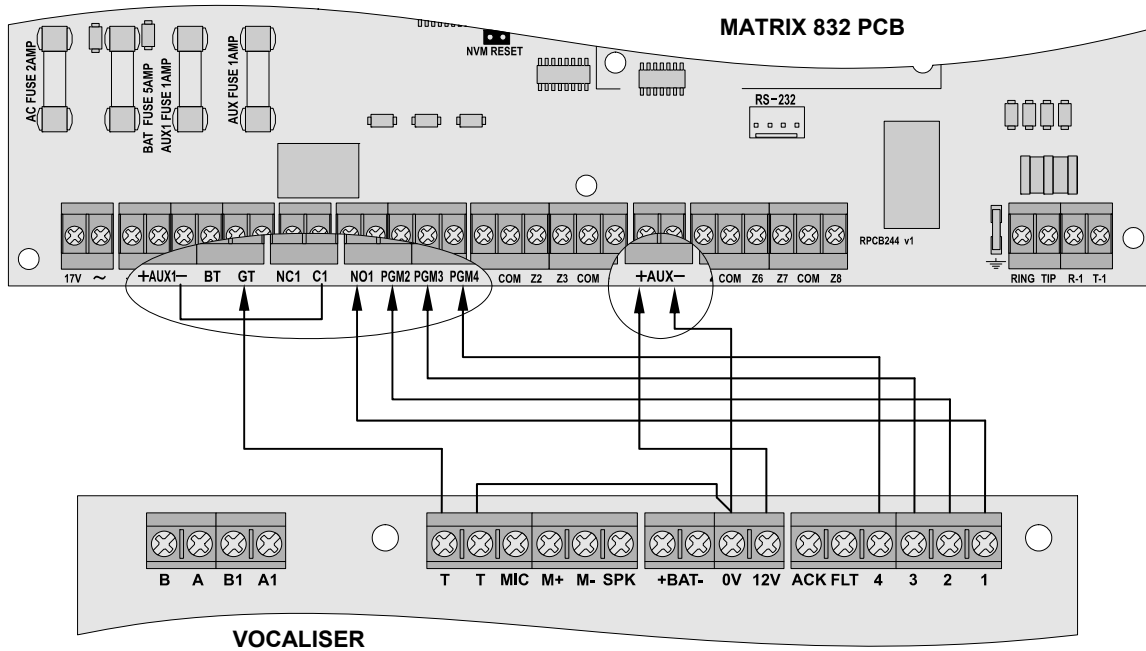

2.13.8 Vocaliser Connection to Matrix 832+

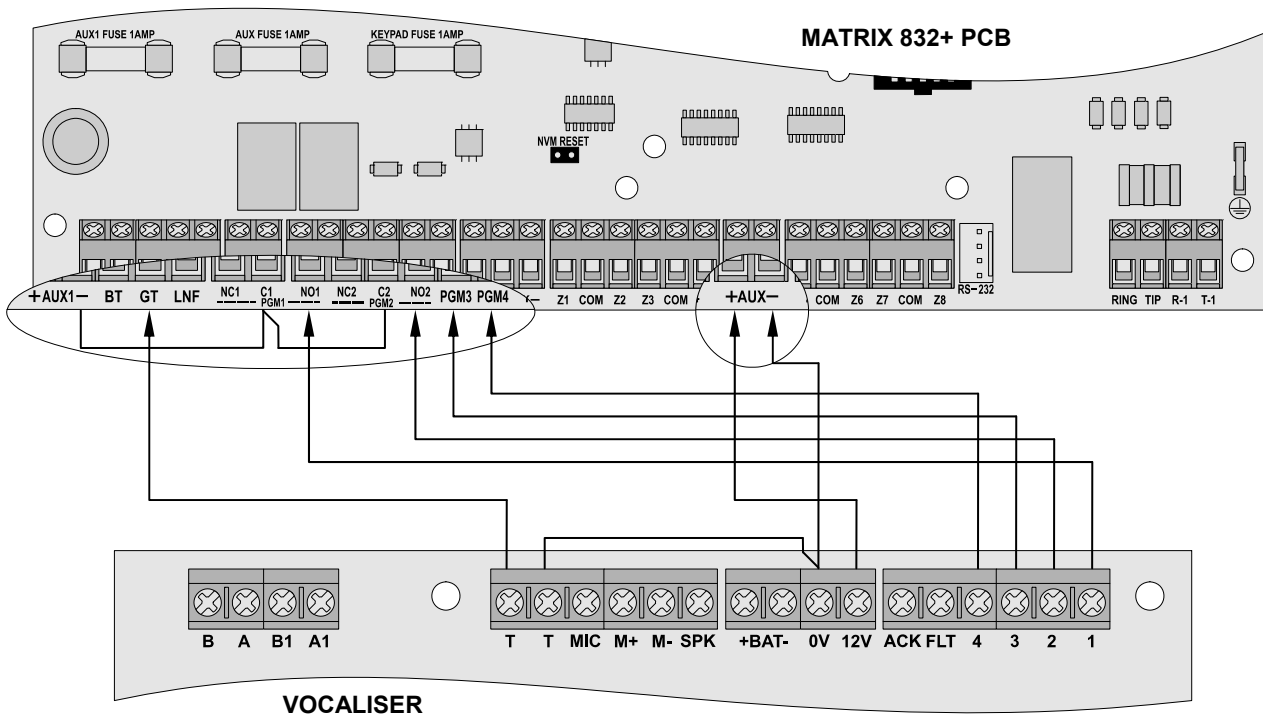

NOTE: See Vocaliser Manual for complete Vocaliser programming options.

In the above instances programmable outputs are programmed as follows:

- PGM1 = "External Bell"*
- PGM2 = "Follow PA"*
- PGM3 = "Follow Fire"*
- PGM4 = "C+" (if Abort function is required)*

2.14 Fire Detector Connection to Matrix

NOTE: Terminal Connections to Matrix 832+ and Matrix 424 are the same as to a Matrix 832.

2.14.1 Two Wire Fire Detector Wiring

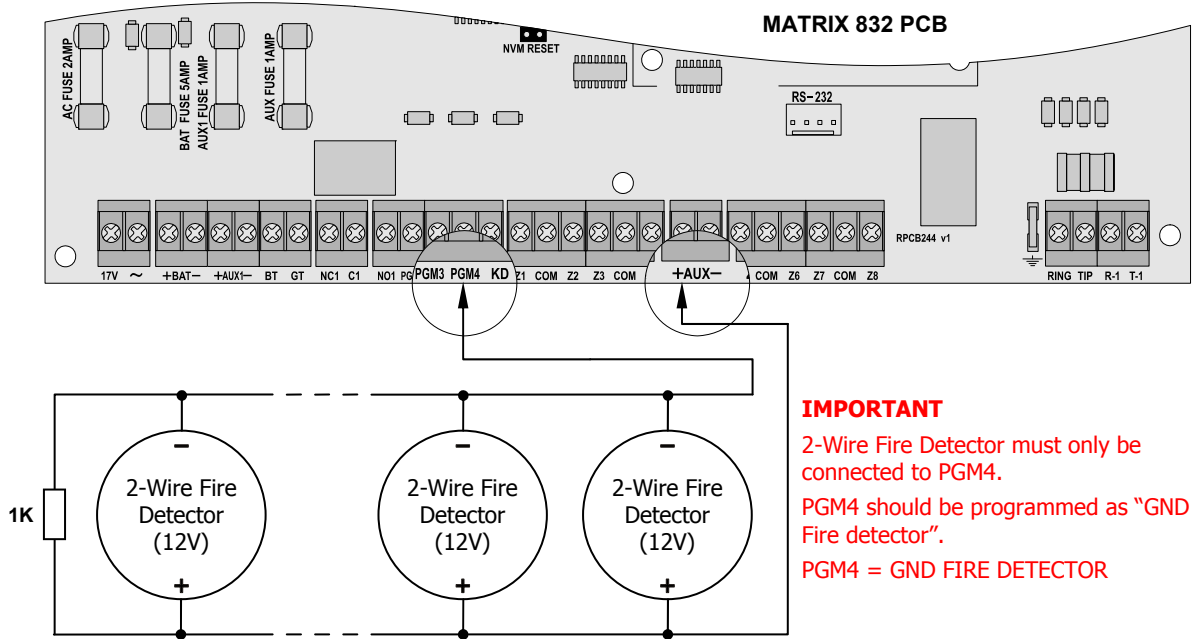

2.14.2 Four Wire Fire Detector Connection to Normally Closed Zone

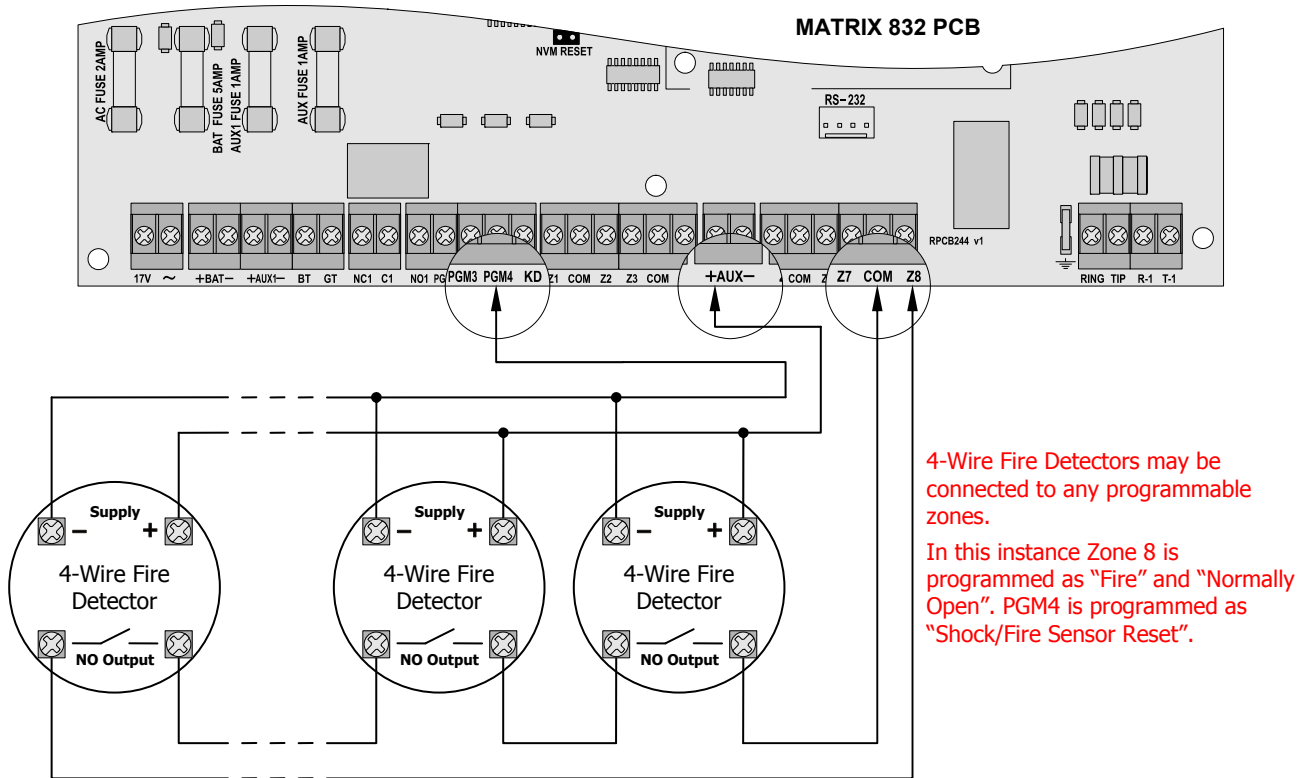

NOTE: The power is supplied to fire detectors via PGM output if the detectors are reset by a momentary power supply disconnection.

2.14.3 Four Wire Fire Detector Connection to End of Line Zones

NOTE 1: 4-Wire Fire Detector Zones should be programmed as "Normally Open".

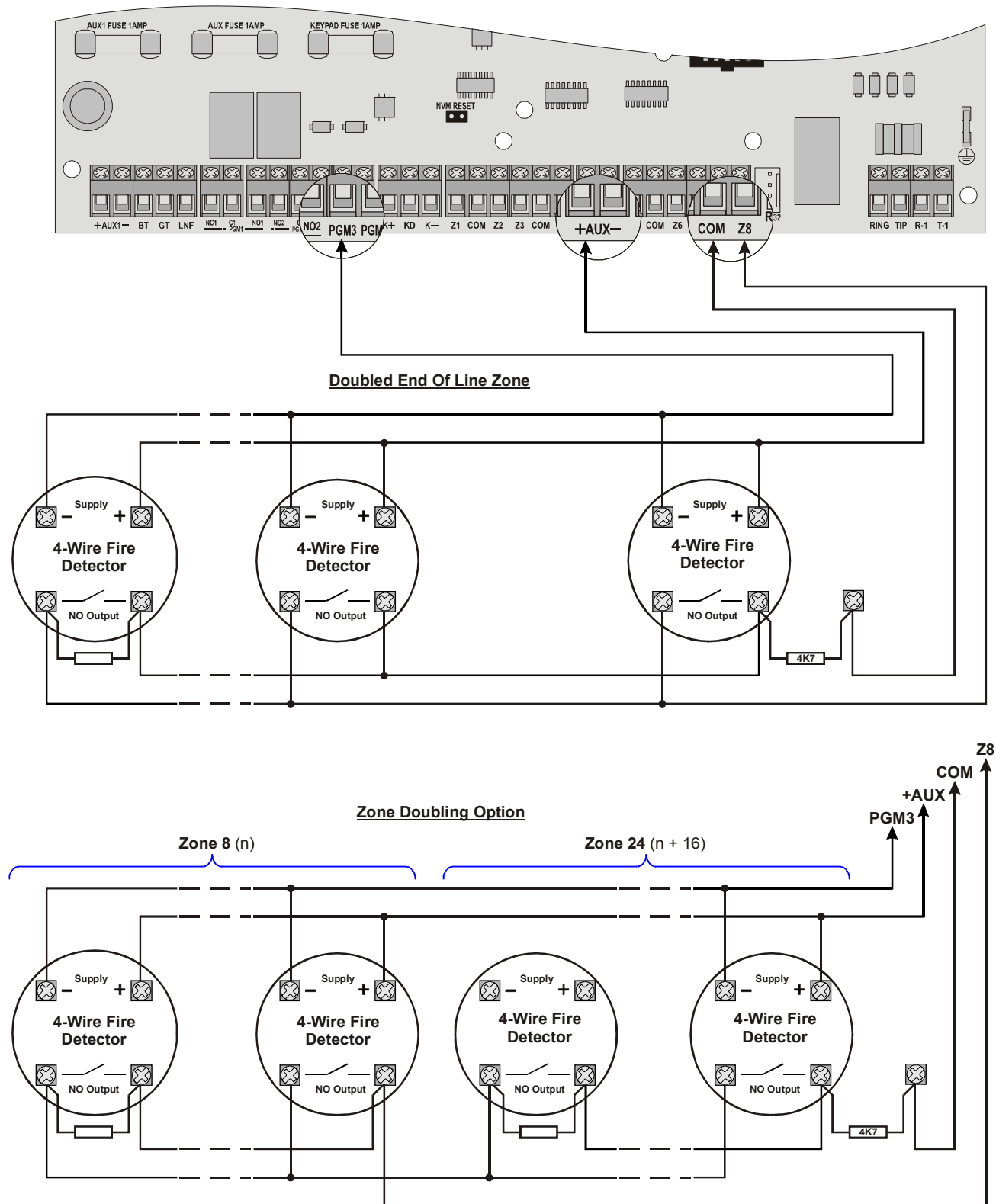

NOTE 2: The power is supplied to fire detectors via PGM outputs if the detectors are reset by a momentary power supply disconnection (PGM output should be programmed as Shock/Fire Sensor Reset and if a relay output is used for connection, terminal C of this output should be connected to 0V ("-" terminal).

3. OPERATING MODES AND KEYPAD/READER INDICATIONS

3.1 Disarmed and Armed Modes

The panel is active for 24 hours a day and the two basic operation modes are ARMED mode and DISARMED mode.

DISARMED



In this mode all zones are disarmed, apart from Fire, Personal Attack, 24 Hr, Medical and Tamper, which are active for 24 hours a day. The Tamper state of all End Of Line zones is always active irrespective of the zone type.

ARMED



In this mode all enabled zones are armed, and if triggered will generate an alarm condition. If an alarm is triggered, internal and external sounders will operate for a programmed period of time. Upon expiry of this time period, the system will automatically rearm.

3.1.1 Available Arm Modes

When arming the control panel, any one of four arm modes can be selected and programmed with different configurations within each individual partition area.

For example:

- Arm A:** Whole partition armed, Premises empty – Away
- Arm B:** Upstairs disarmed, downstairs armed – Home
- Arm C:** Upstairs armed, downstairs disarmed – Home
- Arm D:** Garage armed, the house disarmed – Home

Partition 1	Partition 2	Partition 3	Partition 4
Arm A	Arm A	Arm A	Arm A
Arm B	Arm B	Arm B	Arm B
Arm C	Arm C	Arm C	Arm C
Arm D	Arm D	Arm D	Arm D

3.1.2 Alarm Mode

If the system is triggered, it will generate an alarm state causing the following activations:



The internal keypad sounder / external sounder will activate for the pre-set period of time, and strobe lamp will activate until the user resets the alarm.



A message will be reported to the Central Monitoring Station via telephone or other dedicated channels. Voice messages will be sent to the prescribed telephone numbers.

3.1.3 First to Alarm Mode (FTA)

When the system is in alarm it can reset by entering a valid user code. Entering the user code in this case will allow the panel to enter FTA mode, and the first alarm event will be displayed (any post alarm events may be viewed by pressing the scroll buttons). ***In order to reset the panel to Disarmed mode you must enter the user code once more.***

3.2 Entry/Exit Mode

ENTRY



When the panel is armed and an Entry zone is triggered the Entry timer will begin to countdown. During this period an Entry/Exit tone (single repeated bleep) will be produced by the internal sounder and any zones which are programmed as Access zones will be ignored. If a correct user code is entered before the end of the count down period the panel will return to disarmed mode. If the timer is allowed to elapse before a user code is entered the panel will go into alarm state.

EXIT



Matrix control panels use different types of exit procedures: Timed Exit, Silent Exit and Final Exit. The most popular exit type used is Timed Exit that can operate in two different ways depending on how the Global System Options 2 are programmed: **Procedure 1** - from disarmed mode enter user code. The panel will start arming. If any zones are open then the exit timer will be delayed until the relevant zones are closed. At the end of exit time and providing that all zones have been closed the panel will arm. **Procedure 2** - from disarmed mode enter user code. If any zones are open except Entry / Exit and Access the panel will give an error tone and come back to disarmed mode. If all zones are closed except Entry / Exit and Access the panel will start arming. If the Entry / Exit and Access zones are still open at the end of the exit time the panel will go into alarm. If these are closed then it will arm. If during arming time an Immediate zone is open then the panel will go into alarm.

3.3 Keypad Layout & Button Meanings

ICON Keypad

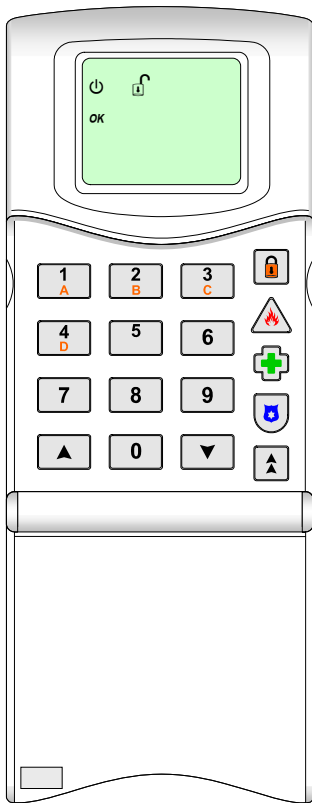

LCD Keypad



	<p align="center">Numerical Buttons Used to enter user codes and programming the system</p>	
	<p align="center">Direction Buttons Used to select options and scroll display</p>	
	<p align="center">Function Button Used to enter / exit user mode, engineer mode, programmable function and to save options</p>	
	<p align="center">A, B, C and D Buttons Used to select Partitions/Arm Modes A, B, C or D</p>	
	<p align="center">Arm Button Used to change arm mode and options</p>	
	<p align="center">FIRE Button Holding this button down for 2 sec. will trigger a Fire Alarm</p>	
	<p align="center">MEDICAL Button Holding this button down for 2 sec. will trigger a Medical Alarm</p>	
	<p align="center">PERSONAL ATTACK Button Holding this button down for 2 sec. will trigger a PA Alarm</p>	
	<p align="center">Menu Button Used to enter and exit menu mode</p>	

3.4 ICON Keypad Indication

		Rest of the World	Denmark, Norway, Finland & Sweden
	Steady	Correct AC & DC power sources	AC power is OK
	Blinking	Indicates DC source (battery) fault	Indicates an AC fault
	Extinguished	Indicates AC fault / no power to panel	No power to the panel

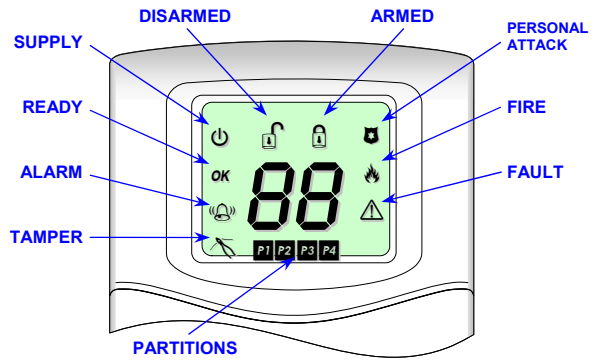

	Steady	In Log display qualifies the alarm type / Day mode indicates activated test zone	
	Blinking	Active alarm in FTA mode	
	Fast Blinking	A latched alarm is active (Denmark, Norway, Finland & Sweden only)	
	Extinguished	No active alarms	

	Steady	OK to Arm, no open zones
	Blinking	Select partitions to arm or disarm / Programming function is active
	Extinguished	One or more open zones or all assigned partitions are already armed

	Steady	The panel is disarmed
	Blinking	Keypad is in user menu mode
	Extinguished	The panel is not disarmed

	Steady	The panel is armed
	Blinking	Indicates the panel is arming with omitted zones
	Extinguished	The panel is not armed

	Steady	Indicates a PA alarm condition (used in log display)
	Blinking	Indicates a PA alarm condition in FTA mode
	Extinguished	No PA active

	Steady	Indicates a Fire alarm condition (used in log display)
	Blinking	Indicates a Fire alarm condition in FTA mode
	Extinguished	No Fire alarm active

	Steady	Indicates a tamper condition (used in log display)
	Blinking	Indicates a tamper condition in FTA mode
	Extinguished	No tamper alarm active

	Steady	Indicates a System Fault
	Blinking	Keypad is in Engineer Mode
	Extinguished	No Fault active

P1 = Partition 1, P2 = Partition 2, P3 = Partition 3, P4 = Partition 4					
	Steady	Partition is Armed		Fast Blinking	Partition is in Alarm
	Blinking	Partition is Arming		Extinguished	Partition is Disarmed

3.5 LCD Keypad Indication

		Rest of the World	Denmark, Finland, Norway & Sweden
⏻	Illuminated	Correct AC & DC power sources	AC power is OK
	Blinking	Indicates DC source (battery) fault	Indicates an AC fault
	Extinguished	Indicates AC fault / no power to panel	No power to the panel

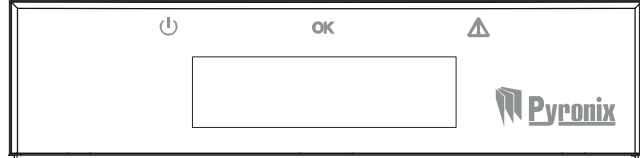

⚠	Illuminated	Indicates a System Fault
	Blinking	Keypad is in Engineer Mode
	Extinguished	No Fault active

OK	Illuminated	OK to Arm, no open zones
	Blinking	Select partitions to arm or disarm / Programming function is active
	Extinguished	One or more open zones or all assigned partitions are already armed

3.6 Proximity Reader Indication

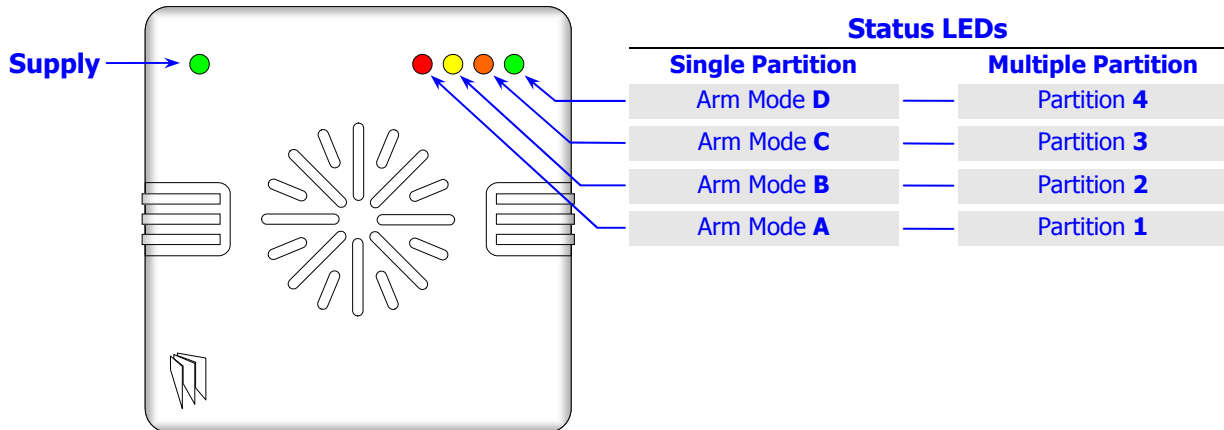

Supply	● Illuminated	Correct AC & DC power sources / communication OK
	⦿ Blinking	Indicates DC source (battery) fault / waiting for communication
	⦿ Fast Blinking	Indicates communication fail
	○ Extinguished	Indicates AC fault / no power to panel

Status LEDs	● Illuminated	Partition or Arm mode is Armed
	⦿ Blinking	Partition or Arm mode is Arming
	⦿ Fast Blinking	Partition or Arm mode is in Alarm
	○ Extinguished	Partition or Arm mode is Disarmed
	⦿ (with wavy lines)	Engineer Mode is active

3.7 Keyfob Layout and Button Meanings

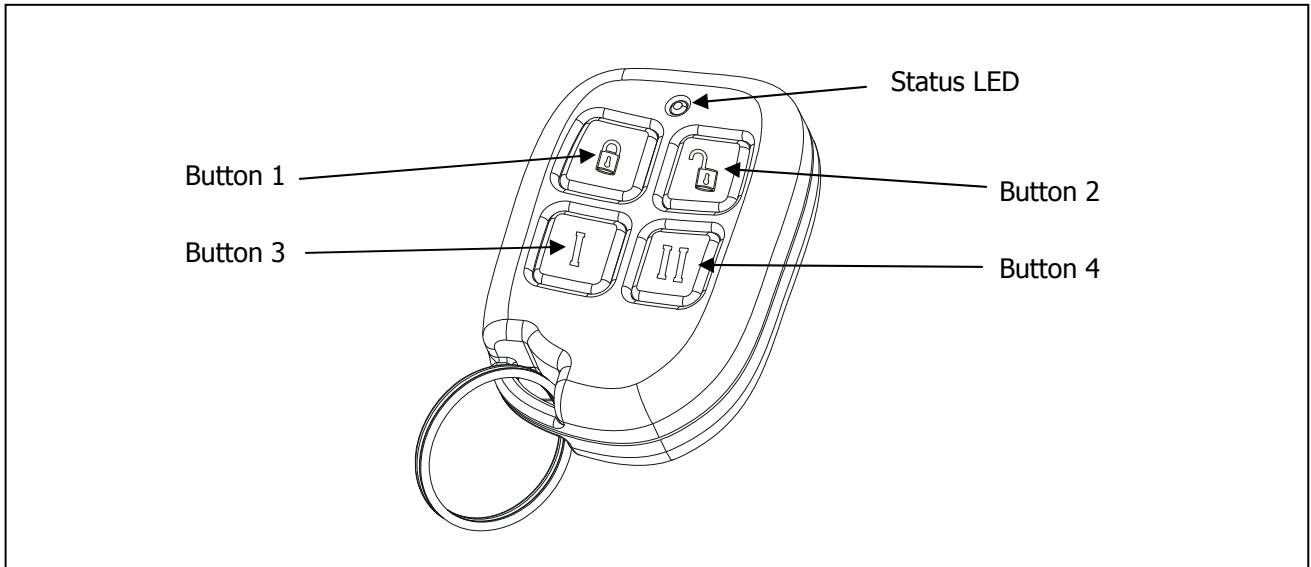

3.7.1 The KF4DW Actions

Action	Description
Arm Mode A	Arm the panel in Arm Mode A
Arm Mode B	Arm the panel in Arm Mode B
Arm Mode C	Arm the panel in Arm Mode C
Arm Mode D	Arm the panel in Arm Mode D
Disarm	Disarm the panel (if currently armed or in First to Alarm)
RKP Controlled Output	RKP controlled output*
Keyfob Controlled Output	Keyfob controlled output*
Fire Alarm	Creates a Fire Alarm
Medical Alarm	Creates a Medical Alarm
Personal Attack	Creates a Personal Attack
Not Used	No Action
Quick Arm Mode A	Quick arm part set A**
Quick Arm Mode B	Quick arm part set B**
Quick Arm Mode C	Quick arm part set C**
Quick Arm Mode D	Quick arm part set D**

***Note 1:** Key fob Controlled is a new programmable output type that can be only be assigned to key fob button presses.

****Note 2:** Quick arm is a new arming method. It does not display open zones whilst arming.

All programmed button actions are on a per partition basis. This means that Partitions 1, 2, 3 & 4 can have totally different sets of button actions from each other. This also means that key fobs assigned to users will only be active in one partition (the first partition if assigned to multiple partitions).

3.7.2 STATUS LEDS

The status LED on the key fob shows the status of the panel when any arm or disarm button is pressed. The indications are shown below:

Panel Status	LED Indication
<i>Disarmed</i>	Green for 3 seconds
<i>Arming</i>	Toggles Green/Red in 3 second bursts until armed
<i>Armed</i>	Red for 3 seconds
<i>In Alarm</i>	Flashing Green for 3 seconds
<i>In FTA (First To Alarm)</i>	Flashing Green for 3 seconds

4. SYSTEM OVERVIEW & TECHNICAL SPECIFICATIONS

This manual supports the following panels: Matrix 424, Matrix 832 and Matrix 832+.

4.1 System Overview

4.1.1 Zones

<u>Zones on Main Board</u>	Matrix 424	4 fully programmable zones
	Matrix 832/832+	8 fully programmable zones
<u>Zone Expander (On Board)</u>		8 fully programmable zones on local plug in expander
<u>Zone Expander MX-RIX</u>	Matrix 424	8 fully programmable zones on remote expander
	Matrix 832/832+	8 fully programmable zones on remote expander
<u>Zone Expander MX-RIX8DW</u>	Matrix 424	8 fully programmable zones on remote expander
	Matrix 832/832+	8 fully programmable zones on remote expander
<u>Maximum Zones Capacity</u>	Matrix 424	28 zones using 3 x zone expanders
	Matrix 832/832+	32 zones using 3 x zone expanders (64 with zone doubling)
<u>Zone Configurations</u>		Normally Closed DEOL – 2 end of line resistors per zone
<u>Zone Types</u>		Entry/Exit, Access, Immediate, Omit (Bypass), Fire, PA, 24Hr, Key Box, Shunt Keypad, Tamper, Latched Key, Momentary Key, Unused, Medical, Arm
<u>Zone Attributes</u>		Chime, Test, Mask, Double knock, Normally open

4.1.2 Programmable Outputs (PGM)

<u>PGM Outputs On-Board</u>	PGM 1 – NO/NC PGM 2 – NO/NC (832+), Active High / Active Low (424/832) PGM 3 – Active High / Active Low PGM 4 – Active High / Active Low
<u>Output Expander MX-ROX</u>	8 open collector/relay expander – installable remotely on keypad bus
<u>Maximum PGM Outputs Capacity</u>	12 outputs using output expander

<u>PGM Options</u>	Not Used	Twin Alert	Follow Battery Faults
	PIR Remote LED enable (E-)	Follow Entry Exit	Follow Duress
	PIR Latch Memory (C+)	Follow Digi Com - Fire Alarm	Follow Disarmed
	RKP Controlled	Follow Digi Com - PA Alarm	Follow System Faults
	Follow Arm/Disarm	Follow Digi Com - Intruder Alarm	Momentary Burglary
	Follow Zone	Follow Digi Com - Open/Close	Follow Momentary 24H
	Follow Tel Line Fail	Follow Digi Com - Spare Alarm	Follow Momentary FIRE
	Follow Kiss Off	Follow Digi Com - Medical Alarm	Follow Momentary MEDICAL
	Shock/Fire Sensor Reset	Follow Digi Com - Confirm Alarm	Follow Momentary PA
	Follow Strobe	Follow Digi Com - Omits (Bypass)	Follow Momentary TAMPER
	Follow Fire Alarm	Follow Hidden Display	Follow Momentary DURESS
	Follow PA Alarm	Follow Mains Fail	Follow Momentary COMFAIL
	Follow Confirmed Alarm	Follow Battery Low	Follow Momentary RKPFAIL

Follow Tamper Alarm External Bell GND Fire Detector	Follow Battery Missing Internal Sounder Follow Medical Alarm	Follow Momentary TESTCALL Status LED Output Keyfob Controlled
---	--	---

4.1.3 Keypads

<u>Type</u>	ICON LCD 32 character
<u>Dedicated Buttons</u>	PA, Fire, Medical
<u>Max Number</u>	Four of same type (max 6 devices in total)
<u>Setting</u>	Private - system status indicated during arming Public - system status indicated in arm mode Hidden - display suppressed after 20 seconds

4.1.4 Proximity Reader (Not approved for use in Denmark, Finland, Norway or Sweden)

<u>Type</u>	Inductively coupled key-fob or card
<u>Max Number</u>	Four of same type (max 6 devices in total)
<u>Setting</u>	Private - system status indicated during arming Public - system status indicated in arm mode

4.1.5 Partitions

<u>Number of Partitions</u>	4 true partitions with common option
<u>Independent Settings</u>	Zones, Keypads, Proximity readers, User codes, User key fobs, PGMS, Timers, Reporting account codes
<u>Arm Modes</u>	4 arm modes per partition (A, B, C, D)
<u>Home/Away allocation</u>	Programmable individual arm modes
<u>Arming Options</u>	Timed exit, Final Exit, Silent arm, Push to arm, Forced Arm
<u>Timers</u>	Entry/Exit, Bell Delay, AC Fault Delay, Telephone Line Fault Delay, Inactivity Arm Time (10-990min.), Auto Arm (time of day), Final Exit Delay, Quartz Correction Factor, Confirmation Time
<u>Real Time Clock</u>	AC frequency Based / Quartz Based

4.1.6 User Codes

<u>Number of User Codes</u>	32 codes (4 to 6 digits)
<u>User Code Attributes</u>	Master / Limited User, Duress, Allow Arm, Allow Disarm, Omit (Bypass) Zones, Temporary, Limited Number of Uses, Forced Re-arm

4.1.7 Central Monitoring Options

<u>Telephone Numbers</u>	9 telephone numbers shared with pager, Pyronix PC format and digital communication formats
<u>Communication Protocols</u>	Contact ID, BSIA Fast Format, Pyronix PC, Pager, MX Voice
<u>Group Reporting to CMS</u>	Events sent to 1 number only Events sent to 2 numbers Events sent to first number with backup of second number
<u>Zone Attributes</u>	Chime, Test, Mask, Double knock, Normally open
<u>Programmable Send Options</u>	In Disarmed Mode, In Arm Modes (A, B, C and D), Restorals, Intruder, PAs, Fire, Maintenance, Open/Close, Medical, Confirmed, Omit (Bypass)
<u>Test Call</u>	Programmable in days, hours and minutes
<u>Telephone Line Monitoring</u>	Yes – with status indication
<u>Telephone Connection</u>	Allows other telephone on the line
<u>Digital Communicator</u>	Analogue line
<u>Lightning Protection</u>	Heavy duty lightning protection 6.75kV/125Amps

4.1.8 Other

<u>Software Support</u>	UDL programming software Pyronix MX-MON monitoring software to be used with: a) Modem + Pyronix format b) RC12/RC112 + Contact ID
<u>Memory Event Log</u>	300 events with time and date Log deletion cannot be allowed either accidentally or on purpose. Log reaction time is more than 30 days and the clock will not change more than + / - 10 min over 1 year at 20c

4.2 Minimum Installation Requirements

In addition to the main alarm panel (Matrix 424, 832 or 832+), and any detectors or sensors, at least one keypad is required. This can be an LCD or ICON keypad. One keypad MUST be set to ID-1. This is the minimum requirement.

A maximum of 6 devices can be attached to the Matrix bus (see also Section 1.8 on page 3: Cabling Rules for the Matrix Bus). The following table shows the maximum number of each device type allowable, whilst at the same time remembering that only 6 devices in total (apart from on-board zone expander) can be on the bus at any one time.

BUS DEVICE	MAX. NUMBER
LCD Keypad	4
ICON Keypad	4
MX-PROX Proximity Reader	4
MX-RIX8DW Remote Wireless Expander	2
MX-RIX Remote Zone Expander with Zone Analyser	2
MX-IX On-board Zone Expander	1
MX-ROX Output Expander	1

4.3 Technical Specification

4.3.1 Main Control Panel

ZONES		PROGRAMMABLE OUTPUTS (PGM)	
Zone Loop Current	0.54mA – Max.	PGM 1	Relay contacts, 30V@3A
DEOL Zone Activation Resistance		PGM 2	
Short Circuit	<800Ω	Matrix 424/832	Open collector, 12V@200mA
Normal	>800Ω to <6kΩ	Matrix 832+	Relay contacts, 30V@3A
Activated	>6kΩ to <36kΩ	PGM 3	Open collector, 12V@200mA
Open Circuit	>36kΩ	PGM 4*	Open collector, 12V@10mA
NC Zone Activation Resistance		*NOTE: PGM 4 is designed for triggering ONLY.	
Normal	<4kΩ	PCB POWER SUPPLY	
Activated	>4kΩ	Power Input	17Vac
Doubled Zone Activation Resistance		Transformer Rating	
Both Zones Normal	>2kΩ to <6kΩ	Plastic Case	21VA
Both Zones Activated	>11kΩ to <35kΩ	Metal Case (832+)	44VA
Zone n Activated	>8kΩ to <11kΩ	EN50131-6 Type	A
Zone n+16 Activated	>6kΩ to <8kΩ	Voltage Output	13.6Vdc@1A regulated
Zone Doubled: Tamper Activated	<2kΩ or >35kΩ	Voltage Range	Max. 13.8V Min. 10.5V
Zone Response Time		Ripple	1% Max.
Standard Zones	300ms	Panel Current Requirement	200mA
Fast Zones	100ms	Constant Current Output	
Only Zone 1 Fast	30ms	Plastic Case	600mA
Zone Protection (832/832+ only)	18V Varister	Metal Case (832+)	1.1A
DIGITAL COMMUNICATOR		Total Current Output	
Telephone Line Monitoring	Yes	Plastic Case	900mA (for 15mins)
Telephone Connection	Allows other tel. on the line	Metal Case (832+)	1.8A (for 15mins)
Digital Communicator	Analogue Line	PCB FUSES	
Lightning Protection	6.75kV / 125A	AC Fuse	Quick blow 2A – F2L
BATTERY		Aux Fuse	Quick blow 1A – F1L
Type	12V Lead acid rechargeable	Aux1 (Bell) Fuse (424 - N/A)	Quick blow 1A – F1L
Battery Charge	Min 6V	Keypad Fuse (832+ only)	Quick blow 1A – F1L
Max Battery Charge Current		Battery Fuse	Slow blow 5A – T5H
Plastic Case	350mA	Mains Fuse	T250mA
Metal Case (832+)	800mA	MECHANICAL	
Battery Charge Method	The Matrix panel monitors the voltage of the battery and commences charging when the battery reaches 12.8V ± 5% and disables charging when it reaches 13.6V ± 5%	Dimensions	
		Plastic Case	340 x 280 x 94.5 mm
		Metal Case (832+)	389.5 x 314.5 x 96.2 mm
		Security Grade	2 - Metal (832+), N/A - Plastic
		Environmental Class	2 - Metal (832+), N/A - Plastic
		TEMPERATURE	

Battery Capacity		Operational	
Plastic Enclosure	2.8 to 7Ah	Plastic Case	0 to +40°C (32 to 104°F)
Metal Enclosure (832+)	2.8 to 17Ah*	Metal Case (832+)	-10 to +55°C (14 to 131°F)#
BAT Terminal Protection	Short & reverse	Storage	-20 to +60°C (-4 to 140°F)
Low Battery Detect Level	10.7V ± 0.2V	Maximum Humidity	
Battery Cut-off Level	10.4V ± 0.2V (with MX-BATT)	Plastic Case	N/A
		Metal Case (832+)	93% Rh

*** NOTE - Italy: To conform with CEI79, the maximum battery size is limited to 12Ah.**

NOTE - Italy: To conform with CEI79 the operational temperature must be 0 to +40°C (32 to 104°F).

4.3.2 Keypads, Proximity Reader & Additional Expanders

ICON KEYPAD

Supply Voltage	13.8V typical (9-16V range)
Supply Current	
Min. brightness setting	40mA @ 13.8V
Max. brightness setting	60mA @ 13.8V
Operating temperature	0 to +50°C (32 to 122°F)
Dimension	75 x 127 x 29 mm

WIRELESS ZONE EXPANDER (MX-RIX8DW)

Supply Voltage	13.8V typical (9-16V range)
Quiescent Current	100mA
Transmitting Current	135mA
All LEDs on current	120mA
Transmission Frequency	868MHz, FM Transceiver Narrow Band
Transmission Method	Fully Encrypted Rolling Code
Transmission Range	300m Free Space
Programming LEDs	11
Supported Zones	8
Supported Keyfobs	32

PROXIMITY READER (MX-PROX)

Supply Voltage	13.8V typical (9-16V range)
Supply Current	Max. 90mA @ 13.8V
Operating temperature	-10 to +50°C (14 to 122°F)
Dimension	85 x 85 x 21 mm

LOCAL PLUG-ON ZONE EXPANDER (MX-IX16)

Supply Voltage	13.8V typical (9-16V range)
Supply Current	15mA ± 5% @ 13.8V
Zone Loop Current	0.54mA – Max.
Zone Activation Resistance	See main control panel data

TRANSISTOR OUTPUT EXPANDER (MX-ROX8T)

Supply Voltage	13.8V typical (9-16V range)
Supply Current	45mA ± 5% @ 13.8V
Outputs	8 Open collectors
Max. Switching Voltage	12Vdc
Max. Switching Current	500mA

LCD KEYPAD

Supply Voltage	13.8V typical (9-16V range)
Supply Current	
Min. brightness setting	20mA @ 13.8V
Max. brightness setting	80mA @ 13.8V
Operating temperature	0 to +50°C (32 to 122°F)
Dimension	139 x 127 x 29 mm

USER KEY FOB (KF4DW)

Battery	3V 360mAh
Battery Life	Up to 1 year
Buttons	4
Programmable Actions	6
Transmission Frequency	868MHz, FM Transceiver Narrow Band
Transmission Method	Fully Encrypted Rolling Code
Colour	Black
Casing	2mm Polycarbonate

VOICE MODULE (MX-VOICE)

Supply Voltage	13.8V typical (9-16V range)
Supply Current	Max. 25mA @ 13.8V
Number of messages	8
Message length	up to 7 sec.

REMOTE MX-RIX WITH ZONE ANALYSER

Supply Voltage	12V typical (9-16V range)
Supply Current	25mA ± 5% @ 13.8V
Zone Loop Current	0.54mA – Max.
Zone Activation Resistance	See main control panel data

RELAY OUTPUT EXPANDER (MX-ROX8R)

Supply Voltage	13.8V typical (9-16V range)
Supply Current	225mA ± 5% @ 13.8V
Outputs	8 NO/NC contacts
Max. Switching Voltage	30V
Max. Switching Current	3A

4.4 Battery Capacity Calculations

Maximum Battery recharge time must not exceed 72 hours to satisfy EN50131-6.

UK Requirements

In the event of mains failure BS4737 Part 1, Section 7.2.1, specifies that a stand-by battery should be able to power the system for a non-alarmed period of 8 hours. The typical Local Authority specified maximum bell alarm period is 20 minutes.

EXAMPLE CALCULATION	Non-alarmed condition 7 hrs 40mins = 7.67Hrs	Alarmed condition 20mins = 0.33Hrs
Control panel	0.200A	0.200A
Keypad	0.050A	0.050A
8 PIRs (15mA each)	0.120A	0.120A
External sounder	0.050A	0.350A
External strobe	0.000A	0.150A
Total current	0.420A	0.870A
Amp/hour capacity	0.420A x 7.67h = 3.22Ah	0.870A x 0.33h = 0.29Ah
Minimum battery capacity: 3.22Ah + 0.29Ah = 3.51Ah		

WARNING: Consult each product's instructions for the actual current values.

4.4.1 Norwegian & Danish Requirements

Required capacity = (18 x A) + (0.5 x B)

Where:

A = Maximum non-alarmed total system current.

B = Maximum alarmed total system current.

4.4.2 Swedish Requirements

Required capacity = 12 x A

Where: A = Maximum total system current.

When all parts are working normally, this equipment in combination with the PSTN and suitable ARC equipment will meet the requirements of ATS2.



EN50131-1
Security Grade 2
Environmental Class 2

This product is suitable for use in systems designed to comply with PD6662:2004 at Security Grade 2 and Environmental Class 2.

5. SAFETY & APPROVALS

 **SAFETY** 

1. A technically competent person must carry out the mains installation in accordance with the national and local electrical installation regulations
2. **Protective Earth:** This equipment must be earthed/grounded. 
3. **Functional Earth:** Must be connected to earth terminal to allow the equipment to operate correctly. Has no safety implications.
4. Connect the unit to a single pole, unswitched, 3 Amp fused spur, using 0.75mm² cable. If the Neutral cannot be positively identified use a double pole disconnect version.
5. Always remove / isolate the mains supply before carrying out any servicing of the panel.
6. **Fuses:** For continued protection against the risk of fire, replace only with the same type and rating of fuse.
7. There are no user serviceable parts inside the equipment.
8. This unit should be mounted so that there will be no outside access to the electrical cable entry point.
9. **Ventilation:** To ensure the correct airflow, always mount the unit vertically with the unit having a clear space on all sides. It must not be covered by clothes, furnishings, boxes, etc. It must not be mounted close to, or above, heat radiating sources.
10. On completion of wiring, use tie-wraps to prevent any loose wires causing a safety hazard.
11. The mechanical mounting of the unit must be secure enough to carry the full weight of the unit including all batteries.
12. **Batteries:** Ensure that the battery terminal connections will not create an electrical short-circuit on the case metalwork when the unit is closed. Use insulated battery lead connectors.
13. Dispose of old batteries as required by environmental legislation / recommendations.
14. The battery case must have a flame-retardant rating of UL94-V2/V1/V0 – IEC60950:2000
15. **Water:** The equipment must be kept free from dampness, water and any other liquids. It is only suitable for installation indoors.



Protective Earth

Must be connected to the electrical installation earth / ground



Protective Bonding

Must be connected to the equipment protective earth terminal



Functional Earth

Must be connected to earth terminal to allow the equipment to operate correctly. Has no safety implications.



Read

Read equipment instructions



Anti-Static precautions are required.

CERTIFICATE OF TEST



KTL

Saxon Way
Priory Park West
Hull HU13 9PB

[Tel: +44 (0) 1482 801801 / Fax: +44 (0) 1482 801806]

Certificate No: 0C4255CEU1C

Page 1 of 2

Testing has been performed in accordance with ISO/IEC17025 criteria on the following apparatus:

Description	Type No	Serial No	Date of Receipt	Build Status
Alarm Panel	Matrix 832	N/A	27 th February 2001	N/A

Test Results:

The apparatus has been tested by KTL to the requirements of the following specifications:

ITU Recommendations K.21 (10/96)

Test	Surge applied	Voltage	Connection point	Result
Table 1 Test 1a) 10 Surges	10/700 μ S Common Mode	5000V	Tip and Ring with respect to earth	Pass
Table 1 Test 1b) 10 Surges	10/700 μ S Differential Mode	5000V	Surge applied to Ring with all other connections earthed	Pass
Table 1 Test 1b) 10 Surges	10/700 μ S Differential Mode	5000V	Surge applied to Tip with all other connections earthed	Pass
Table 1 Test 1a) 10 Surges	10/700 μ S Common Mode	6750V	Tip and Ring with respect to earth	Pass
Table 1 Test 1b) 10 Surges	10/700 μ S Differential Mode	6750V	Surge applied to Ring with all other connections earthed	Pass
Table 1 Test 1b) 10 Surges	10/700 μ S Differential Mode	6750V	Surge applied to Tip with all other connections earthed	Pass

1. This declaration is only applicable in respect of the particular samples of equipment tested & the specific tests performed. It does not guarantee or imply that any approval has or will be granted by KTL or any other body.
2. The results listed relate only to the items listed, & were obtained between the date of receipt of the samples & issue date of this certificate.
3. Full details of test results, modifications and marginal results are held by KTL under reference number 0C4255. A test report can be produced on formal written request, but additional costs will be incurred.
4. KTL is the trading name of Kingston Laboratories Ltd.

Ver c25/1

CERTIFICATE OF TEST



KTL
Saxon Way
Priory Park West
Hull HU13 9PB
 [Tel: +44 (0) 1482 801801 / Fax: +44 (0) 1482 801806]

Certificate No: 0C4255CEU1C

Page 2 of 2

Notes

All tests were applied with a Semitron RSUP001 3 pole Gas Discharge Tube fitted to the telecommunications input connector.

A full functional check was performed after each set of surge tests by establishing a bi-directional communications link to the Pyronix Central station using the PSTN line of the alarm panel.

Applicant Pyronix Limited

Address Pyronix House
 Braithwell Way
 Hellaby
 Rotherham
 England
 S66 8QY

Authorised by: 

Certificate Issue Date: 2nd March 2001

P Hesp, Senior Product Safety Engineer. Authorised Copy No: 1

1. This declaration is only applicable in respect of the particular samples of equipment tested & the specific tests performed. It does not guarantee or imply that any approval has or will be granted by KTL or any other body.
2. The results listed relate only to the items listed, & were obtained between the date of receipt of the samples & issue date of this certificate.
3. Full details of test results, modifications and marginal results are held by KTL under reference number 0C4255. A test report can be produced on formal written request, but additional costs will be incurred.
4. KTL is the trading name of Kingston Laboratories Ltd.

Ver c25/1



TEST CERTIFICATE



Certificate No: 1719

Page No: 1 of 1

We hereby declare that a sample of apparatus (The Apparatus) known as:

The Apparatus: Intruder Alarm Panel**Type No:** Matrix 832, Matrix 424 & Sterling 10**Serial No:** N/A

has been tested by KTL and was found to comply with the requirements of the following specifications:

Specifications: EN60950: 2000

Full details of the tests, dates of tests, results and product definition are contained in KTL Test Report(s):

Test Report No: 0C4256CEU1**Report Issue Date:** 10.10.01

Apparatus submitted by: Pyronix Ltd
Unit 2
Braithwell Way
Hellaby
Rotherham
S66 8QY
United Kingdom

Manufacturer: As above**Authorised by:**

Certificate Issue Date: 10.04.02

N Parrott, Safety Group Manager

Authorised Copy No:

1. This declaration is issued subject to KTL's standard terms and conditions, copies of which can be obtained from KTL.
2. This declaration is only applicable in respect of the particular sample of equipment tested and the specific tests performed and does not guarantee or imply that any approval has or will be granted by KTL or any other body.
3. KTL is the trading name of Kingston Laboratories Ltd.
4. Tests marked "Not UKAS Accredited" on this Certificate are not included in the UKAS accreditation Schedule for our Laboratory.

KTL, Saxon Way, Priory Park West, Hull, HU13 9PB, UK Tel: +44 (0)1482 801801 Fax: +44 (0)1482 801806

ver: c19/6



The maximum voltage applied to the equipment must not exceed the safety extra low voltage SELV limits specified in IEC60950 / EN60950 / UL60950 30VDC / 30VAC / 42.4Vpeak.

If you need to switch greater voltage, current or power you will require the use of a separate external switching relay.



HTTP://www.pyronix.com

 PYRONIX Ltd
 Pyronix House
 Braithwell Way
 Hellaby, Rotherham
 South Yorkshire
 S66 8QY
 ENGLAND, UK

COMPLIANCE

EU Declaration of Conformity
EN45014

Manufacturer: As above

Details of electrical equipment

Model name(s) Matrix 832+ (Plastic & Metal Housing)
 MX-ROX8T, MX-ROX8R, MX-RIA, MX-RIX
 LCD, LED, Icon keypads, MX-PROX

Description: Control & Indicating Equipment
 Remote expanders, keypads

Directives that this equipment complies with: RTTE 99/05/EC

Harmonised Standards applied in order to verify compliance with the Directives:
 EN50081-1: 1992 Class B
 EN50130-4: 1995 + A1: 1998
 EN301489-1: V1.4.1
 EN301489-3: V1.3.1
 EN300330-2: V1.1.1

Testing Agency	Status	ISO/IEC17025	Certificate No	Cert. Date	Category
York EMC Services Three Lanes End Centre Methley Castleford West Yorkshire WF10 1PN	Testhouse	UKAS 1574	5212TC	02/01/02	EMC
			5503/TR/1	01/04/03	EMC
			5494/TR/1	20/03/03	EMC
			5430/TR/1	02/01/03	EMC
KTL, Saxon Way Testhouse UKAS 0971 EMC Priory Park West Hull, Humberside HU13 PB9	Testhouse	UKAS 0971	1C5217CEU1	01/10/02	Safety
			1C521CCB1	11/10/02	Safety
			2H5972GEU1	21/11/02	Radio

Year in which CE mark was affixed: 2002

Authorized signatory:

Manufacturer

Authorized Representative

Date of issue



01 June 03

Name:

.....
 Craig Leivers

.....
 Not applicable

Place of issue
 Pyronix Ltd



Pyronix Limited
Pyronix House
Braithwell Way
Hellaby, Rotherham
S66 8QY, UK

Customer Support line (UK only): 0845 6434 999 (local rate)
Or telephone: 01709 535225

Hours of business: 7:00 AM – 7:30 PM, Monday to Friday

Email: customer.support@pyronix.com

Website: www.pyronix.com
www.dd243.co.uk
www.matrixpanel.com

WARRANTY

This product is sold subject to our standard warranty conditions and is warranted against defects in workmanship for a period of 2 years. In the interest of continuing improvement of quality, customer care and design, Pyronix reserve the right to