

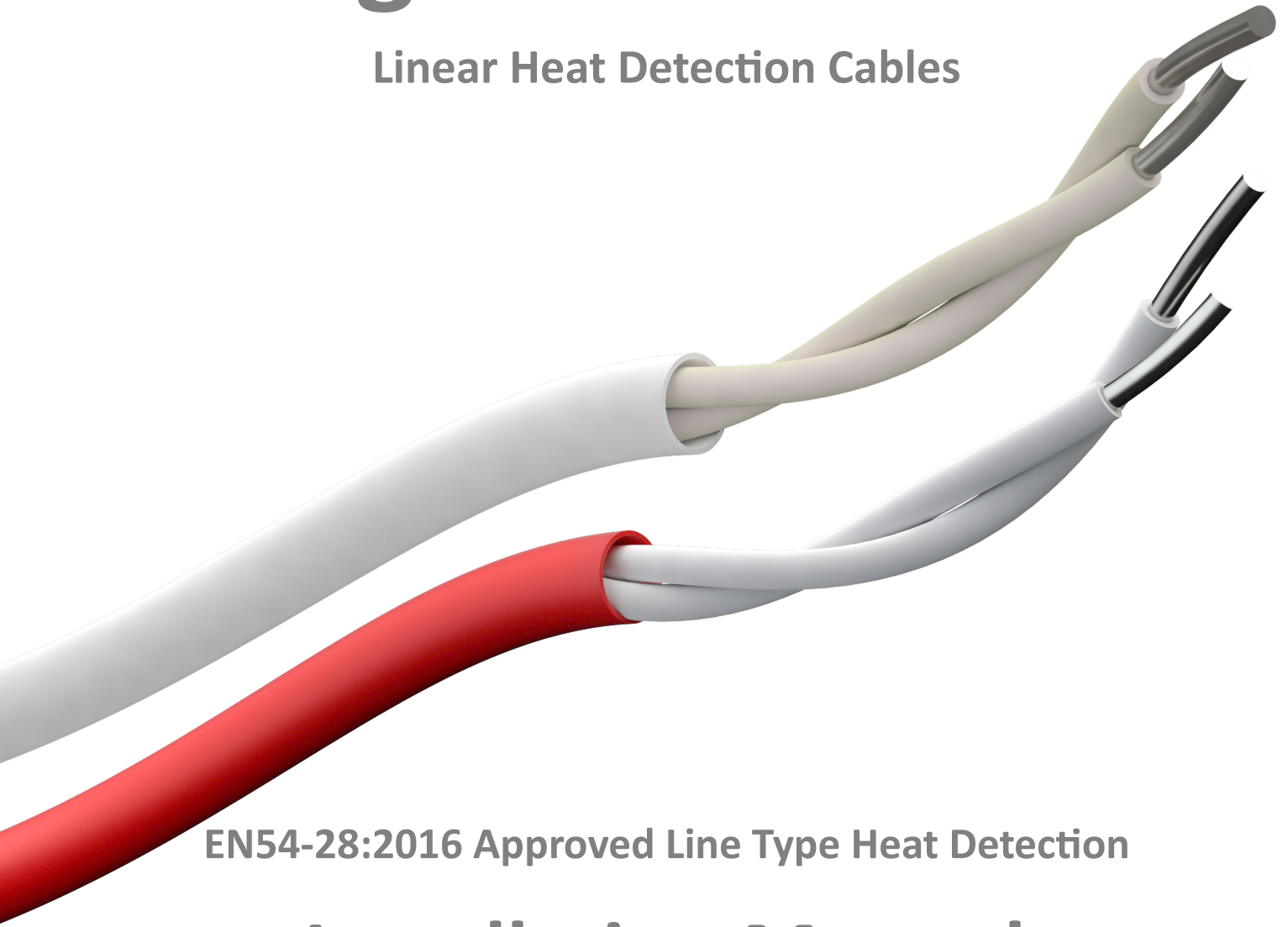

SIGNALINE
HEAT

Signaline FT-EN

Linear Heat Detection Cables



EN54-28:2016 Approved Line Type Heat Detection

Installation Manual



Tel: +44(0)1252 725257

Revision 2 (2023)

© 2023/24 LGM Products Ltd.

Email: sales@lgmproducts.com

Web: www.signaline.com

ISO 9001:2015 certified

Address: LGM Products Ltd, Unit 3 Quantum Business Park, Beacon Hill Road, Hampshire, GU52 8EA

United Kingdom



Contents

Key Points

General Overview

Product Features

Signaline LocatorPlus-EN

Technical Data

Product Specification

Typical System Configuration

Installation

Installation Hardware

Area Protection

Splicing

Testing and Verification

Functional Testing

Please read this instruction leaflet thoroughly before commencing installation.



Key Points

- ⇒ Install the Signaline FT-EN Linear Heat Detection cable accordingly to meet local and country installation requirements.
- ⇒ Signaline FT-EN Linear Heat Detection cables must be installed by a qualified professional in accordance with BS 5839-1:2017 (or country equivalent) and IEC 60364 and authorities having jurisdiction.
- ⇒ Support the Signaline FT-EN Linear Heat Detection cables at 0.6m (2ft) to 1.5m (5ft) intervals.
- ⇒ Using a multimeter, test the Signaline FT-EN Linear Heat Detection cable **on the reel** before installation.
- ⇒ Ensure the maximum ambient temperature rating of the Signaline FT-EN Linear Heat Detection cable will not be exceeded during transport, storage or normal operating conditions.
- ⇒ Ensure adjacent runs of Signaline FT-EN Linear Heat Detection cables are spaced at less than or equal to the maximum approved spacing.
- ⇒ Ensure the Signaline FT-EN Linear Heat Detection cables is not in contact with any material which may conduct heat onto the cable directly.
- ⇒ A silicone sleeve should be placed between fixing clips and Signaline FT-EN Linear Heat Detection cable.
- ⇒ Ensure any cable glands used are tightened to form a secure and moisture proof seal around the Signaline FT-EN Linear Heat Detection cable.



Key Points

- ⇒ **Avoid allowing the Signaline FT-EN Linear Heat Detection cable to come in contact with any material which acts as a heat sink. This may delay the activation of the cable in alarm situations.**
- ⇒ **Do not connect two lengths of Signaline FT-EN Linear Heat Detection cable which have different action temperatures.**
- ⇒ **Do not connect lengths of Signaline FT-EN Linear Heat Detection cables in ‘T’ connections or spurs.**
- ⇒ **Do not paint the Signaline FT-EN Linear Heat Detection cables.**
- ⇒ **Do not place the Signaline FT-EN Linear Heat Detection cable under excessive tension.**
- ⇒ **Do not bend the Signaline FT-EN Linear Heat Detection cable at right angles. The minimum bend radius is 100mm (4”).**
- ⇒ **Avoid subjecting the Signaline FT-EN Linear Heat Detection cables to mechanical damage which could result in false activation.**
- ⇒ **Avoid laying the Signaline FT-EN Linear Heat Detection cables in areas where heavy traffic may result in the cable being crushed.**



General Overview

Signaline FT-EN Linear Heat Detection cable uses fixed temperature detection technology to provide a straightforward method for sensing increases in temperature. The Signaline FT-EN Linear Heat Detection cable can offer an alternative overheat protection in a vast range of applications and environments, from tunnels, cable trays, warehousing to sensing increases in temperature within escalators and other applications where many risks of fire are hidden from view.

Signaline FT-EN Linear Heat Detection cable is a non-resettable line-type heat detector. The two twisted cores are held apart by an advanced temperature sensitive polymer (see Fig. 1). At a temperature, set by the manufacturing processes of the cable, the temperature sensitive polymer surrounding the two cores softens, allowing the cores to come into contact. This is an irreversible process and once the Signaline FT-EN Linear Heat Detection cable has activated, the section which has triggered must be cut out and replaced (not the whole cable).

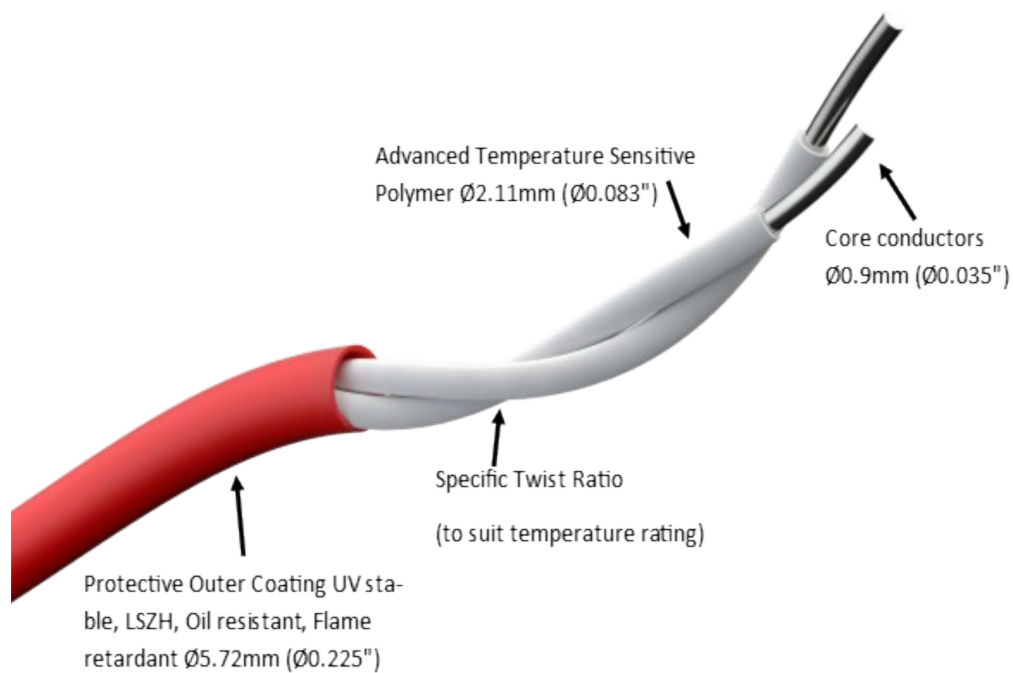

Fig. 1 Construction of Signaline FT-EN Linear Heat Detection cable (optional stainless steel out braiding applied to models with suffix ‘-S’)



Product Features

- EN54-28:2016 approved.
- CE Marked.
- RoHS compliant.
- Up-to 1,000m (3,280ft) per zone (when used with the Signaline LocatorPlus-EN).
- Fixed sensitivity and detection along the entire length of Signaline FT-EN Linear Heat Detection cable.
- Low smoke and halogen free (LSZH).
- Flame retardant.
- UV stable and hydrocarbon resistant.
- Optional stainless steel over-braiding for increased mechanical protection (for models with suffix '-S').

Signaline LocatorPlus-EN

Signaline FT-EN Linear Heat Detection cable has been approved to EN54-28:2016 in conjunction with the Signaline LocatorPlus-EN. The Signaline LocatorPlus-EN monitors up-to two zones of Signaline FT-EN Linear Heat Detection cable and has separate fault and alarm outputs for each zone.

It is straightforward to connect the Signaline LocatorPlus-EN to a conventional fire alarm panel or to an addressable system using an I/O, zone or switch monitor module.

It also has a built-in display which shows the state of each zone, including the distance in meters and feet to the alarm point, if an alarm is triggered. Furthermore, an RS-485 Modbus RTU/ASCII output is available as standard for integration with a PLC or SCADA system.



TECHNICAL DATA	
Product Type	Non-resettable line-type heat detector
Construction	Overall insulated, twisted pair of stainless steel cores
Insulation	1kV tested protective outer coatings
Additional insulation options	Stainless Steel over-braiding*
Approvals	EN54-28:2016, CE Marked, RoHS Compliant
Max zone length	1,000m (3,280ft) (when used with Signaline LocatorPlus-EN)
Wire overall diameter	5.72mm (0.225in) standard LSZH Coating 6.30mm (0.248in) with Stainless Steel additional braid
Min bend radius	100mm (4") 125mm (5in) with Stainless Steel Braid
ELECTRICAL	
Max voltage rating	49Vac, 74Vdc
Resistance	Approx 1.25ohms per metre per core

*A stainless steel outer braid is available on the entire range of Signaline FT-EN Linear Heat Detection cable and provides extra mechanical protection to the inner detection cable without impeding on the performance of the cable. It is frequently installed in abrasive environments.



Product Specification

Product	Signaline FT-68-EN	Signaline FT-68-EN-S
UL File No	S24913	S24913
UL Model Designation	FT-68-EN	FT-68-EN-S
Description	Signaline FT-68-EN Linear Heat Detector	Signaline FT-68-EN Linear Heat Detector with Stainless Steel outer
EN54-28 Performance Type	T068-V10-A045	T068-V10-A045
EN54-28 Environmental	II	II
Nominal Activation	68°C	68°C
Maximum Ambient	45°C	45°C
Minimum Ambient	-40°C	-40°C
Humidity	0% to 98% RH	0% to 98% RH
Colour	Red	Silver braid over Red
Capacitance per m	<100pF	<100pF
Inductance per m	<3.2μH	<3.2μH
Resistance per m	Approx. 2.5ohms	Approx. 2.5ohms
Diameter	5.72mm +/- 0.12mm (0.225" +/- 0.005")	6.3mm +/- 0.12mm (0.248" +/- 0.005")
Minimum bend radius	100mm (4")	125mm (5")
Features	Low-Smoke Zero Halogen (LSZH), UV Stable, Oil resistant, Flame retardant	Low-Smoke Zero Halogen (LSZH), UV Stable, Oil resistant, Flame retardant, increased mechanical strength and abrasion resistance



Product Specification

Product	Signaline FT-78-EN	Signaline FT-78-EN-S
UL File No	S24913	S24913
UL Model Designation	FT-78-EN	FT-78-EN-S
Description	Signaline FT-78-EN Linear Heat Detector	Signaline FT-78-EN Linear Heat Detector with Stainless Steel outer Braid
EN54-28 Performance Type	T078-V10-A045	T078-V10-A045
EN54-28 Environmental	III	III
Nominal Activation	78°C	8°C
Maximum Ambient	45°C	45°C
Minimum Ambient	-40°C	-40°C
Humidity	0% to 98% RH	0% to 98% RH
Colour	Red	Silver braid over Red
Capacitance per m	<100pF	<100pF
Inductance per m	<3.2µH	<3.2µH
Resistance per m	Approx. 2.5ohms	Approx. 2.5ohms
Diameter	5.72mm +/- 0.12mm (0.225" +/- 0.005")	6.3mm +/- 0.12mm (0.248" +/- 0.005")
Minimum bend radius	100mm (4")	125mm (5")
Features	Low-Smoke Zero Halogen (LSZH), UV Stable, Oil resistant, Flame retardant	Low-Smoke Zero Halogen (LSZH), UV Stable, Oil resistant, Flame retardant, increased mechanical strength and abrasion resistance



Product Specification

Product	Signaline FT-88-EN	Signaline FT-88-EN-S
UL File No	S24913	S24913
UL Model Designation	FT-88-EN	FT-88-EN-S
Description	Signaline FT-88-EN Linear Heat Detector	Signaline FT-88-EN Linear Heat Detector with Stainless Steel outer Braid
EN54-28 Performance Type	T088-V10-A065	T088-V10-A065
EN54-28 Environmental Group	III	III
Nominal Activation Temperature	88°C	88°C
Maximum Ambient Temperature	65°C	65°C
Minimum Ambient Temperature	-40°C	-40°C
Humidity	0% to 98% RH	0% to 98% RH
Colour	White	Silver braid over White
Capacitance per m	<100pF	<100pF
Inductance per m	<3.2µH	<3.2µH
Resistance per m	Approx. 2.5ohms	Approx. 2.5ohms
Diameter	5.72mm +/- 0.12mm (0.225" +/- 0.005")	6.3mm +/- 0.12mm (0.248" +/- 0.005")
Minimum bend radius	100mm (4")	125mm (5")
Features	Low-Smoke Zero Halogen (LSZH), UV Stable, Oil resistant, Flame retardant	Low-Smoke Zero Halogen (LSZH), UV Stable, Oil resistant, Flame retardant, increased mechanical strength and abrasion resistance



Product Specification

Chemical Resistance	These ratings are given as a guide and for constant exposure to the chemicals shown a normal (10 to 30°C) temperatures. (* - not recommended, ***** - little or
Ammonia, Liquid/Gas	*****
Butane	**
Copper Nitrate	*****
Fuel Oils	***
Gasoline	***
Hydrofluoric Acid	****
Kerosene	*
Diesel Fuel	***
Acetic Acid	****

Technical drawings of Signaline FT-EN Linear Heat Detection cable are available upon request



Typical System Configuration

The Signaline FT-EN Linear Heat Detection cable is designed to work with the Signaline LocatorPlus-EN and Signaline End-of-Line Unit (FT-EOL-EN). The Signaline LocatorPlus-EN has been specifically designed to monitor the Signaline FT-EN Linear Heat Detection cable and be immune to any electro-magnetic interference that may be present in the typical applications the cable is installed into.

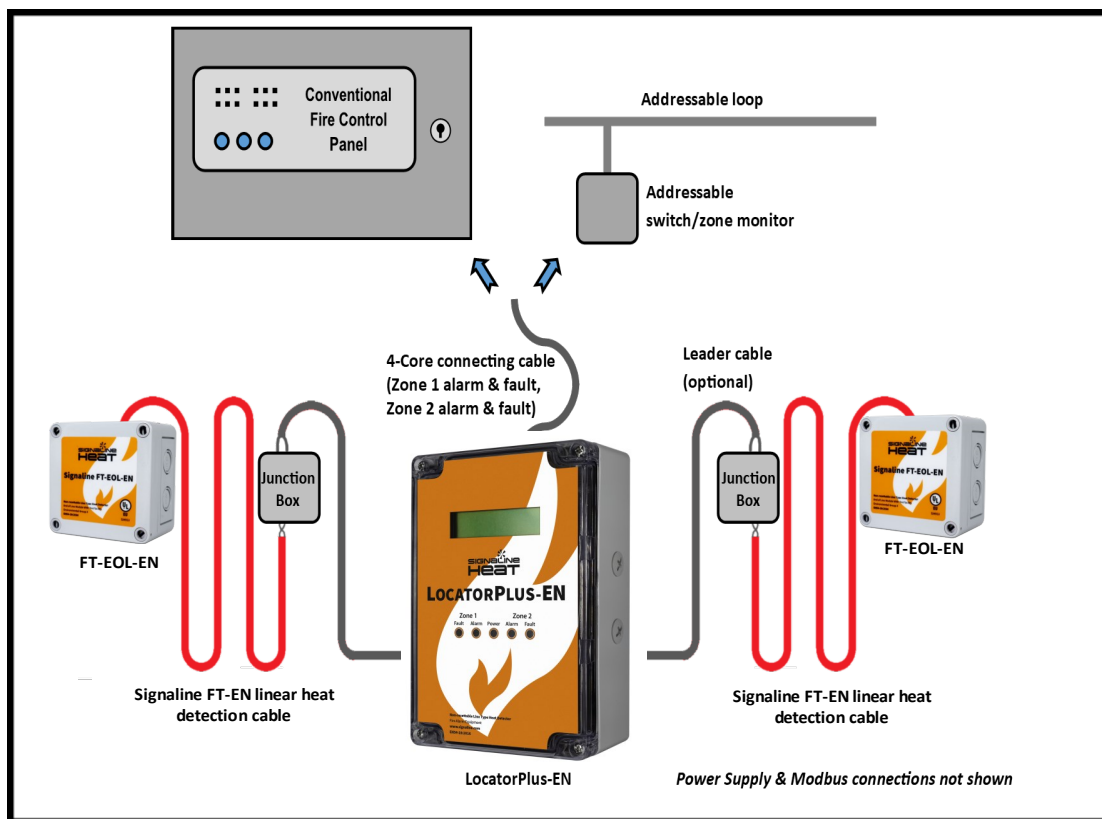

Fig 2. Typical schematic for Signaline FT-EN Linear Heat Detection cable with Signaline LocatorPlus-EN and Signaline FT-EOL-EN



Installation

Leader Cable

An approved type of leader cable, preferably fire rated cable, should be used between the fire alarm control panel/addressable input module and the Signaline LocatorPlus-EN, and, if required, the Signaline LocatorPlus-EN and then Signaline FT-EN Linear Heat Detection cable.

A secure waterproof (IP65 or greater) junction box must be used to connect the leader cable to the Signaline FT-EN Linear Heat Detection cable from the Signaline LocatorPlus-EN.

It is recommended that leader cable with the following minimum cross sectional area (CSA) per conductor is used when using the maximum length of Signaline FT-EN Linear Heat Detection cable. Consult with the authority having jurisdiction and the fire alarm control panel manufacturer for further information.

Recommended Maximum Leader Cable Length and CSA for copper conductors (with maximum length of Signaline FT-EN Linear Heat Detection cable 1000m/3,280ft)

0.8 mm² (18AWG) — Up to 1,000m (3,280ft)

Low Temperature Installation Considerations

Signaline FT-EN Linear Heat Detection cable is suitable for use in ambient temperatures down to -40°C (-40°F). Such conditions occur in cold storage freezer warehouses and outdoors for example. Take special care when installing Signaline FT-EN Linear Heat Detection cable in low ambient temperatures or for use in low temperature conditions careful consideration of the conditions and environment should be undertaken.

Wherever possible the Signaline FT-EN Linear Heat Detection cable should not be installed when the ambient temperature is below -10°C (14°F). The materials within the Signaline FT-EN Linear Heat Detection cable will become less flexible and are more prone to damage. If the ambient temperature is likely to drop significantly after installing the Signaline FT-EN Linear Heat Detection cable take into account linear shrinkage of the cable when attaching support brackets. The Signaline FT-EN Linear Heat Detection cable can shrink in length by 12% at -40°C (-40°F).



Installation

Low Temperature Installation Considerations Continued

A silicone pad should be placed around the Signaline FT-EN Linear Heat Detection cable before clipping into the support bracket. This prevents damage to the Signaline FT-EN Linear Heat Detection cable and reduces the heat sink effect of the clip.

The minimum bend radius of the detection Signaline FT-EN Linear Heat Detection cable should be increased to 150mm (6") to account for the reduced flexibility. The maximum distance between support brackets should be no more than 1m (3ft) and it is important to support the Signaline FT-EN Linear Heat Detection cable close to either side of any bend. Ensure any junction boxes other enclosures are waterproof and suitable for the expected operating temperatures.



Installation Hardware

There are many applications where Signaline FT-EN Linear Heat Detection cable can be used to provide protection. Please visit www.signaline.com for more information on available fittings.

Signaline FT-EN Linear Heat Detection cable should be adequately supported to prevent sagging. Ideally cable supports should be placed every 1m (3ft) and no more than 1.5m (5ft) apart. It may be necessary to place more supports around corners and other transition areas.

Care should be taken when mounting the Signaline FT-EN Linear Heat Detection cable in clips (or equivalent) that they are not done so tight as to crush the cable. The Signaline FT-EN Linear Heat Detection cable should be held firmly without deformation.

Avoid placing excessive tension on the Signaline FT-EN Linear Heat Detection cable, no greater than 50N. Ensure also that the minimum bend radius is observed at all times – 100mm (4").

It is of particular importance to use a silicone pad between the Signaline FT-EN Linear Heat Detection cable and the fixing clip if the metal clip is exposed to the sun or attached to a piece of equipment which may get hot and transfer the heat to the cable. See examples fixing methods in Fig. 3.

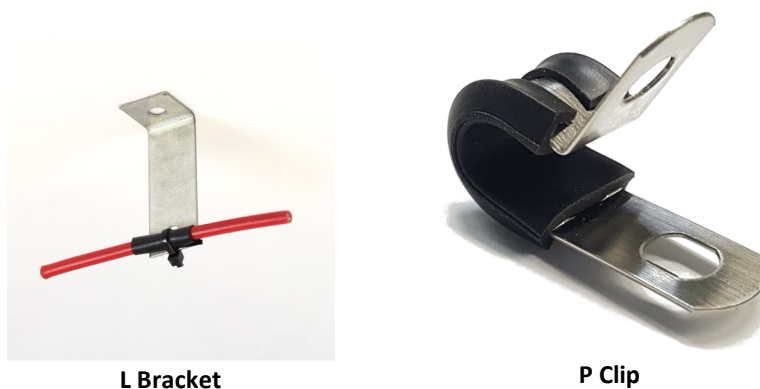

Fig 3. example fixing methods



Installation Hardware

Where possible, it is preferable to install the Signaline FT-EN linear heat detector cables in one continuous run of cable with as few splices as possible.

When pulling the detection cable from a reel, a reel stand must be used. Do not pull the cable off the reel vertically with the reel stationary as this will twist and damage the cable.

A guide wire may be required for installations where supporting the cable at the recommended spacing is not practical. Ensure the diameter or gauge of the guide wire is adequate for the distance which is being spanned. Commercially available stainless steel wire with a diameter of approximately 2mm is suitable for use as a guide wire.

Connections into junction boxes and other enclosures must use strain relief connectors which provide dust and moisture protection (IP65 or greater protection). The standard diameter of detection cable is 5.72mm (0.225"). Suitable cable glands are shown in Fig. 4 which fit an M12 standard knockout.

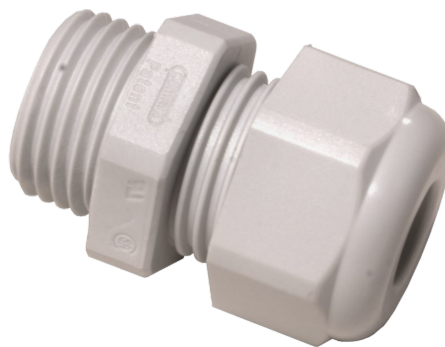

Fig. 4 Typical cable gland for Signaline FT-EN range of cables connected to an enclosure



Area Protection

Signaline FT-EN Linear Heat Detection cable is suitable for broad or wide area detection of overheat or fire conditions, e.g. warehouses etc. The Signaline FT-EN Linear Heat Detection cable should be installed with a minimum distance between the cable and the ceiling of 20mm to allow hot gases rising from an event to trigger the detection cable.

Maximum support spacings should be followed and the cable securely attached to the ceiling or beams. Section 22.6 of BS 5839-1 (or country equivalent) should be consulted for guidelines of installing line-type heat detectors. The main point to consider is that no point in the protected space is further than 5.3m from the nearest point on a line-type heat detector.

However, this value may change for sloped ceilings and ceilings which have closely spaced structural beams, for example.

For an application which has a smooth ceiling, this means the maximum spacing between runs of Signaline FT-EN Linear Heat Detection cable is 10.6m. See Fig. 5. for further details.



Area Protection Continued

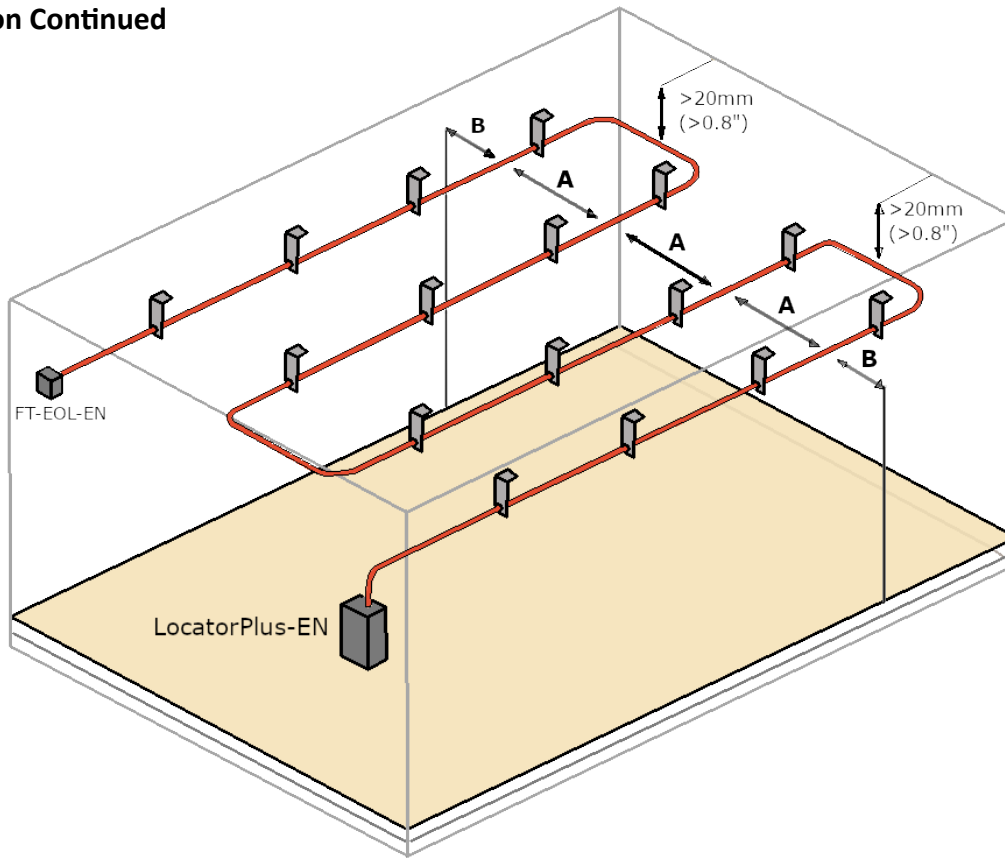

Spacing between parallel runs of LHD cable (A)
No greater than 10.6m for ceiling height up-to 7.5m

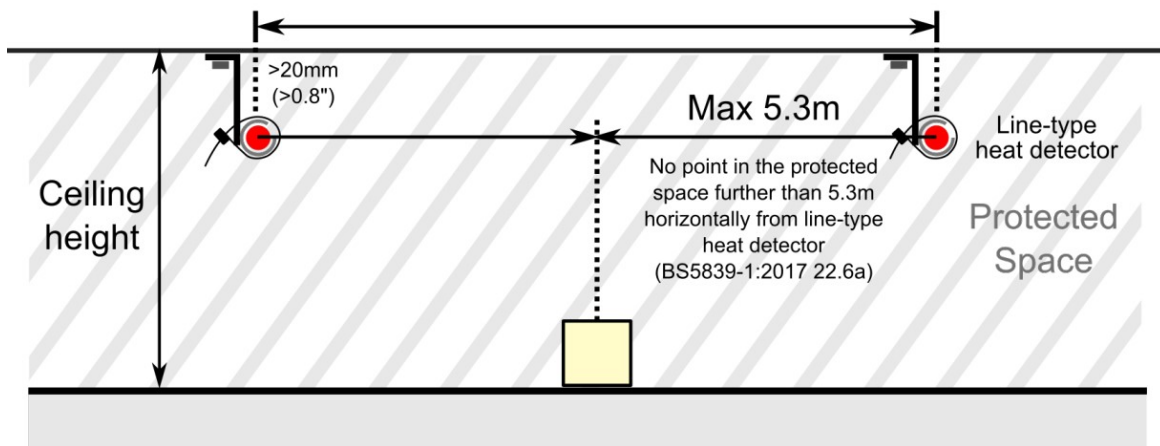

Fig. 5 Spacing requirements for Signaline FT-EN Linear Heat Detection cables



Splicing

If the Signaline FT-EN Linear Heat Detection cable gets damaged or has triggered due to an overheat condition, the section can be removed and a new section spliced in its place.

Care should be taken during splicing to ensure the two core conductors do not come into contact with each other at any point and the final spliced joint is secure and made waterproof.

It is recommended that a junction box is used, with an IP rating suitable for the environment, to join two lengths of Signaline FT-EN Linear Heat Detection cable together.

Do not solder the two cores of the Signaline FT-EN Linear Heat Detection cable together.

A secure connection should be made with DIN rail mounted terminal blocks or equivalent.

When replacing a section of the Signaline FT-EN Linear Heat Detection cable due to an overheat condition having occurred, the section including at least 3m (10ft) either side of the known event should be replaced.



Testing and Verification

Routine maintenance and checking should be carried out to ensure the Signaline FT-EN Linear Heat Detection cable will function as expected and has not been damaged etc.

A visual inspection should be performed to ensure all support brackets and other aspects of the physical installation are suitable. The cable should also be visually checked for damage to the outer or inner insulation. Check to make sure the silicone pads are correctly installed around the cable in the clips.

Any joints which have been made should be checked to make sure they are secure.

Electrical tests should be carried out to determine the circuit created by the conductors is working. Remove the conductors from the fire alarm control panel or addressable switch monitor and measuring the resistance across them. The resulting value should equal the end-of-line resistance plus approximately 1250Ω/km for each leg. To test in circuit with a fire alarm control panel or addressable switch monitor re-attach the Linear Heat Detection cable.

Shorting out the Signaline FT-EOL-EN should put the system into alarm. Disconnecting either leg from the Signaline FT-EOL-EN device should put the system into fault.



Functional Testing

Signaline FT-EN Linear Heat Detection cable is non-resettable – any section which has alarmed must be cut out and replaced. Therefore functional testing of the installed cable will not normally be carried out.

However, if required, any Signaline FT-EN Linear Heat Detection cable leftover after installation can be used to periodically perform a functional test. A 1m (3ft) section of cable should be attached between the end of the Signaline FT-EN Linear Heat Detection cable run and the Signaline FT-EOL-EN. Using a suitable device heat the test length of detection cable up. Once the action temperature (including any tolerances) has been reached the system should alarm. Ensure the test length is removed before placing the system back into normal operation.

The Signaline FT-EN Linear Heat Detection cable is part of the Signaline family of products

To see our full range visit www.signaline.com



For product support, contact us at technical@lgmproducts.com

Or call 01252 725257 to speak to our sales team

Tel: +44(0)1252 725257

Revision 2 (2023)

© 2023/24 LGM Products Ltd.

Email: sales@lgmproducts.com

Web: www.signaline.com

ISO 9001:2015 certified

Address: LGM Products Ltd, Unit 3 Quantum Business Park, Beacon Hill Road, Hampshire, GU52 8EA

United Kingdom