

COMPAS

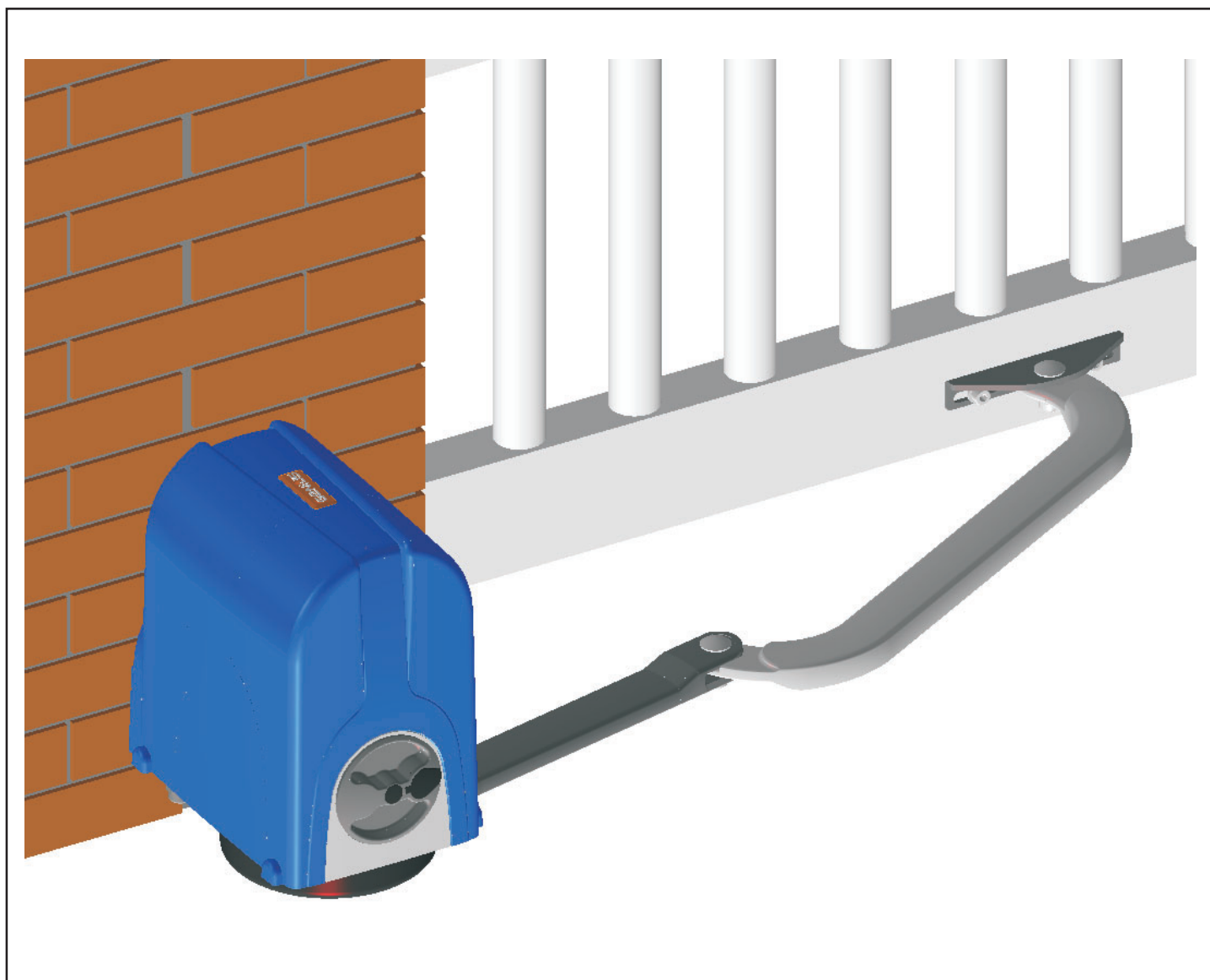

GENIUS®

**COMPANY
WITH QUALITY SYSTEM
CERTIFIED BY DNV
= UNI EN ISO 9001/2000=**



AVVERTENZE PER L'INSTALLATORE OBBLIGHI GENERALI PER LA SICUREZZA

- 1) **ATTENZIONE! È importante per la sicurezza delle persone seguire attentamente tutta l'istruzione. Una errata installazione o un errato uso del prodotto può portare a gravi danni alle persone.**
- 2) Leggere attentamente le istruzioni prima di iniziare l'installazione del prodotto.
- 3) I materiali dell'imballaggio (plastica, polistirolo, ecc.) non devono essere lasciati alla portata dei bambini in quanto potenziali fonti di pericolo.
- 4) Conservare le istruzioni per riferimenti futuri.
- 5) Questo prodotto è stato progettato e costruito esclusivamente per l'utilizzo indicato in questa documentazione. Qualsiasi altro utilizzo non espressamente indicato potrebbe pregiudicare l'integrità del prodotto e/o rappresentare fonte di pericolo.
- 6) GENIUS declina qualsiasi responsabilità derivata dall'uso improprio o diverso da quello per cui l'automatismo è destinato.
- 7) Non installare l'apparecchio in atmosfera esplosiva: la presenza di gas o fumi infiammabili costituisce un grave pericolo per la sicurezza.
- 8) Gli elementi costruttivi meccanici devono essere in accordo con quanto stabilito dalle Norme EN 12604 e EN 12605.
Per i Paesi extra-CEE, oltre ai riferimenti normativi nazionali, per ottenere un livello di sicurezza adeguato, devono essere seguite le Norme sopra riportate.
- 9) GENIUS non è responsabile dell'inosservanza della Buona Tecnica nella costruzione delle chiusure da motorizzare, nonché delle deformazioni che dovessero intervenire nell'utilizzo.
- 10) L'installazione deve essere effettuata nell'osservanza delle Norme EN 12453 e EN 12445. Il livello di sicurezza dell'automazione deve essere C+D.
- 11) Prima di effettuare qualsiasi intervento sull'impianto, togliere l'alimentazione elettrica e scollegare le batterie.
- 12) Prevedere sulla rete di alimentazione dell'automazione un interruttore onnipolare con distanza d'apertura dei contatti uguale o superiore a 3 mm. È consigliabile l'uso di un magnetotermico da 6A con interruzione onnipolare.
- 13) Verificare che a monte dell'impianto vi sia un interruttore differenziale con soglia da 0,03 A.
- 14) Verificare che l'impianto di terra sia realizzato a regola d'arte e collegarvi le parti metalliche della chiusura.
- 15) L'automazione dispone di una sicurezza intrinseca antischiacciamento costituita da un controllo di coppia. È comunque necessario verificarne le soglie di intervento secondo quanto previsto dalle Norme indicate al punto 10.
- 16) I dispositivi di sicurezza (norma EN 12978) permettono di proteggere eventuali aree di pericolo da **Rischi meccanici di movimento**, come ad Es. schiacciamento, convogliamento, cesoiamento.
- 17) Per ogni impianto è consigliato l'utilizzo di almeno una segnalazione luminosa nonché di un cartello di segnalazione fissato adeguatamente sulla struttura dell'infisso, oltre ai dispositivi citati al punto "16".
- 18) GENIUS declina ogni responsabilità ai fini della sicurezza e del buon funzionamento dell'automazione, in caso vengano utilizzati componenti dell'impianto non di produzione GENIUS.
- 19) Per la manutenzione utilizzare esclusivamente parti originali GENIUS.
- 20) Non eseguire alcuna modifica sui componenti facenti parte del sistema d'automazione.
- 21) L'installatore deve fornire tutte le informazioni relative al funzionamento manuale del sistema in caso di emergenza e consegnare all'Utente utilizzatore dell'impianto il libretto d'avvertenze allegato al prodotto.
- 22) Non permettere ai bambini o persone di sostare nelle vicinanze del prodotto durante il funzionamento.
- 23) Tenere fuori dalla portata dei bambini radiocomandi o qualsiasi altro datore di impulso, per evitare che l'automazione possa essere azionata involontariamente.
- 24) L'applicazione non può essere utilizzata da bambini, da persone con ridotte capacità fisiche, mentali, sensoriali o da persone prive di esperienza o del necessario addestramento.
- 25) Il transito tra le ante deve avvenire solo a cancello completamente aperto.
- 26) L'utente utilizzatore deve astenersi da qualsiasi tentativo di riparazione o d'intervento e deve rivolgersi solo ed esclusivamente a personale qualificato GENIUS o centri d'assistenza GENIUS.
- 27) Tutto quello che non è previsto espressamente in queste istruzioni non è permesso

IMPORTANT NOTICE FOR THE INSTALLER GENERAL SAFETY REGULATIONS

- 1) **ATTENTION! To ensure the safety of people, it is important that you read all the following instructions. Incorrect installation or incorrect use of the product could cause serious harm to people.**
- 2) Carefully read the instructions before beginning to install the product.
- 3) Do not leave packing materials (plastic, polystyrene, etc.) within reach of children as such materials are potential sources of danger.
- 4) Store these instructions for future reference.
- 5) This product was designed and built strictly for the use indicated in this documentation. Any other use, not expressly indicated here, could compromise the good condition/operation of the product and/or be a source of danger.
- 6) GENIUS declines all liability caused by improper use or use other than that for which the automated system was intended.
- 7) Do not install the equipment in an explosive atmosphere: the presence of inflammable gas or fumes is a serious danger to safety.
- 8) The mechanical parts must conform to the provisions of Standards EN 12604 and EN 12605.
For non-EU countries, to obtain an adequate level of safety, the Standards mentioned above must be observed, in addition to national legal regulations.
- 9) GENIUS is not responsible for failure to observe Good Technique in the construction of the closing elements to be motorised, or for any deformation that may occur during use.
- 10) The installation must conform to Standards EN 12453 and EN 12445. The safety level of the automated system must be C+D.
- 11) Before attempting any job on the system, cut out electrical power and disconnect the batteries.
- 12) The mains power supply of the automated system must be fitted with an all-pole switch with contact opening distance of 3mm or greater. Use of a 6A thermal breaker with all-pole circuit break is recommended.
- 13) Make sure that a differential switch with threshold of 0.03 A is fitted upstream of the system.
- 14) Make sure that the earthing system is perfectly constructed, and connect metal parts of the means of the closure to it.

- 15) The automated system is supplied with an intrinsic anti-crushing safety device consisting of a torque control. Nevertheless, its tripping threshold must be checked as specified in the Standards indicated at point 10.
- 16) The safety devices (EN 12978 standard) protect any danger areas against **mechanical movement Risks**, such as crushing, dragging, and shearing.
- 17) Use of at least one indicator-light is recommended for every system, as well as a warning sign adequately secured to the frame structure, in addition to the devices mentioned at point "16".
- 18) GENIUS declines all liability as concerns safety and efficient operation of the automated system, if system components not produced by GENIUS are used.
- 19) For maintenance, strictly use original parts by GENIUS.
- 20) Do not in any way modify the components of the automated system.
- 21) The installer shall supply all information concerning manual operation of the system in case of an emergency, and shall hand over to the user the warnings handbook supplied with the product.
- 22) Do not allow children or adults to stay near the product while it is operating.
- 23) Keep remote controls or other pulse generators away from children, to prevent the automated system from being activated involuntarily.
- 24) Transit through the leaves is allowed only when the gate is fully open.
- 25) The User must not in any way attempt to repair or to take direct action and must solely contact qualified GENIUS personnel or GENIUS service centres.
- 26) Anything not expressly specified in these instructions is not permitted.

CONSIGNES POUR L'INSTALLATEUR RÈGLES DE SÉCURITÉ

- 1) **ATTENTION! Il est important, pour la sécurité des personnes, de suivre à la lettre toutes les instructions. Une installation erronée ou un usage erroné du produit peut entraîner de graves conséquences pour les personnes.**
- 2) Lire attentivement les instructions avant d'installer le produit.
- 3) Les matériaux d'emballage (matière plastique, polystyrène, etc.) ne doivent pas être laissés à la portée des enfants car ils constituent des sources potentielles de danger.
- 4) Conserver les instructions pour les références futures.
- 5) Ce produit a été conçu et construit exclusivement pour l'usage indiqué dans cette documentation. Toute autre utilisation non expressément indiquée pourrait compromettre l'intégrité du produit et/ou représenter une source de danger.
- 6) GENIUS décline toute responsabilité qui dériverait d'usage improprie ou différent de celui auquel l'automatisme est destiné.
- 7) Ne pas installer l'appareil dans une atmosphère explosive: la présence de gaz ou de fumées inflammables constitue un grave danger pour la sécurité.
- 8) Les composants mécaniques doivent répondre aux prescriptions des Normes EN 12604 et EN 12605.
Pour les Pays extra-CEE, l'obtention d'un niveau de sécurité approprié exige non seulement le respect des normes nationales, mais également le respect des Normes susmentionnées.
- 9) GENIUS n'est pas responsable du non-respect de la Bonne Technique dans la construction des fermetures à motoriser, ni des déformations qui pourraient intervenir lors de l'utilisation.
- 10) L'installation doit être effectuée conformément aux Normes EN 12453 et EN 12445. Le niveau de sécurité de l'automatisme doit être C+D.
- 11) Couper l'alimentation électrique et déconnecter la batterie avant toute intervention sur l'installation.
- 12) Prévoir, sur le secteur d'alimentation de l'automatisme, un interrupteur onnipolaire avec une distance d'ouverture des contacts égale ou supérieure à 3 mm. On recommande d'utiliser un magnétothermique de 6A avec interruption onnipolaire.
- 13) Vérifier qu'il y ait, en amont de l'installation, un interrupteur différentiel avec un seuil de 0,03 A.
- 14) Vérifier que la mise à terre est réalisée selon les règles de l'art et y connecter les pièces métalliques de la fermeture.
- 15) L'automatisme dispose d'une sécurité intrinsèque anti-écrasement, formée d'un contrôle du couple. Il est toutefois nécessaire d'en vérifier le seuil d'intervention suivant les prescriptions des Normes indiquées au point 10.
- 16) Les dispositifs de sécurité (norme EN 12978) permettent de protéger des zones éventuellement dangereuses contre les **Risques mécaniques du mouvement**, comme l'écrasement, l'acheminement, le cisaillement.
- 17) On recommande que toute installation soit dotée au moins d'une signalisation lumineuse, d'un panneau de signalisation fixé, de manière appropriée, sur la structure de la fermeture, ainsi que des dispositifs cités au point "16".
- 18) GENIUS décline toute responsabilité quant à la sécurité et au bon fonctionnement de l'automatisme si les composants utilisés dans l'installation n'appartiennent pas à la production GENIUS.
- 19) Utiliser exclusivement, pour l'entretien, des pièces GENIUS originales.
- 20) Ne jamais modifier les composants faisant partie du système d'automatisme.
- 21) L'installateur doit fournir toutes les informations relatives au fonctionnement manuel du système en cas d'urgence et remettre à l'Usager qui utilise l'installation les "Instructions pour l'Usager" fournies avec le produit.
- 22) Interdire aux enfants ou aux tiers de stationner près du produit durant le fonctionnement.
- 23) Eloigner de la portée des enfants les radiocommandes ou tout autre générateur d'impulsions, pour éviter tout actionnement involontaire de l'automatisme.
- 24) The application cannot be used by children, by people with reduced physical, mental, sensorial capacity, or by people without experience or the necessary training.
- 25) Le transit entre les vantaux ne doit avoir lieu que lorsque le portail est complètement ouvert.
- 26) L'utilisateur doit s'abstenir de toute tentative de réparation ou d'intervention et doit s'adresser uniquement et exclusivement au personnel qualifié GENIUS ou aux centres d'assistance GENIUS.
- 27) Tout ce qui n'est pas prévu expressément dans ces instructions est interdit.

ADVERTENCIAS PARA EL INSTALADOR REGLAS GENERALES PARA LA SEGURIDAD

- 1) **ATENCIÓN! Es sumamente importante para la seguridad de las personas seguir atentamente las presentes instrucciones. Una instalación incorrecta o un uso impropio del producto puede causar graves daños a las personas.**
- 2) Leer detenidamente las instrucciones antes de instalar el producto.
- 3) Los materiales del embalaje (plástico, poliestireno, etc.) no deben dejarse al alcance de los niños, ya que constituyen fuentes potenciales de peligro.
- 4) Guardar las instrucciones para futuras consultas.
- 5) Este producto ha sido proyectado y fabricado exclusivamente para la utilización indicada en el presente manual. Cualquier uso diverso del previsto podría perjudicar el funcionamiento del producto y/o representar fuente de peligro.

INDEX

1. COMPONENTS	pag.7
3. DIMENSIONS	pag.7
2. TECHNICAL SPECIFICATIONS	pag.7
4. ELECTRICAL CONNECTIONS	pag.8
5. INSTALLATION	pag.8
5.1. PRELIMINARY CHECKS	pag.8
5.2. INSTALLATION DIMENSIONS	pag.8
5.3. INSTALLING THE OPERATOR	pag.8
5.4. WIRING THE OPERATOR	pag.9
5.5. POSITIONING THE MECHANICAL STOPS	pag.10
6. AUTOMATED SYSTEM TEST	pag.10
7. MANUAL MODE OPERATION	pag.10
8. SPECIAL APPLICATIONS	pag.10
9. MAINTENANCE	pag.10
10. REPAIRS	pag.10
11. ACCESSORIES	pag.10

CE DECLARATION OF CONFORMITY FOR MACHINES (DIRECTIVE 98/37/EC)

Manufacturer: GENIUS S.p.A.

Address: Via Padre Elzi, 32 - 24050 - Grassobbio BERGAMO - ITALY

Declares that: Operator mod. **COMPAS 24 - COMPAS 24 C** powered on 230Vac

- is built to be integrated into a machine or to be assembled with other machinery to create a machine under the provisions of Directive 98/37/EC;
- conforms to the essential safety requirements of the following EEC directives:
 - 2006/95/EC Low Voltage directive.
 - 2004/108/EC Electromagnetic Compatibility directive.

and also declares that it is prohibited to put into service the machinery until the machine in which it will be integrated or of which it will become a component has been identified and declared as conforming to the conditions of Directive 89/392/EEC and subsequent modifications assimilated in Italian National legislation under Presidential decree No.459 of 24 July 1996.

Grassobbio, 23-01-2008

The Managing Director
D. Gianantoni



COMPAS AUTOMATED SYSTEM

The **COMPAS** automated system consists of a non-reversing electro-mechanical operator available in two versions:

- **COMPAS 24C** with built-in control unit
- **COMPAS 24** without control unit

The operator was designed for automating the opening of gates with one or two leaves, with maximum length of 2.5m.

A handy, safe releases system, with personalised key, moves the leaf in case of a power cut or fault.

The two articulated arms are designed for moving gates with very large pilasters. The distance between the hinge and the gearmotor securing point can be up to 220 mm. Thanks to the special geometry of the two arms, all possible shearing points have been eliminated.

- **Correct operation and the specifications declared in these instructions can be obtained only with GENIUS accessories and safety devices.**
- **To make an installation conforming to current safety regulations, the absence of a mechanical anti-crushing clutch, means that a control unit with an adjustable electronic clutch device is necessary.**
- **The COMPAS automated system was designed and built for controlling vehicle access - do not use for any other purpose.**



2. TECHNICAL SPECIFICATIONS

MODEL	COMPAS 24 C	COMPAS 24
Power supply	230 V~	-
Electric motor	24 Vdc	24 Vdc
Absorbed power	120 W	110 W
Max torque	250 N/m	250 N/m
Max angular speed	13 °/sec	13 °/sec
Max leaf ¹⁻²	2.5 m	2.5 m
Max leaf weight ²	See graph	
Use frequency at 20°C	80 cycles/day	80 cycles/day
Consecutive cycles at 20°C	30	30
Maximum continuous operating time	O.T. 17 min.	
Protection Class	IP44	IP44
Operating ambient temperature	-20°C +55°C	-20°C +55°C
Noise level	<70 dB (A)	
Operator weight	8.7 Kg	7 Kg
Dimensions	See fig. 2	

¹ For leaves with a length L>2m, an electric lock must be installed to guarantee locking the leaf.

² The weight **P** of the leaf is a function of the length **L**. Check if your leaf is in the zone shown in the graph underneath.

1. COMPONENTS

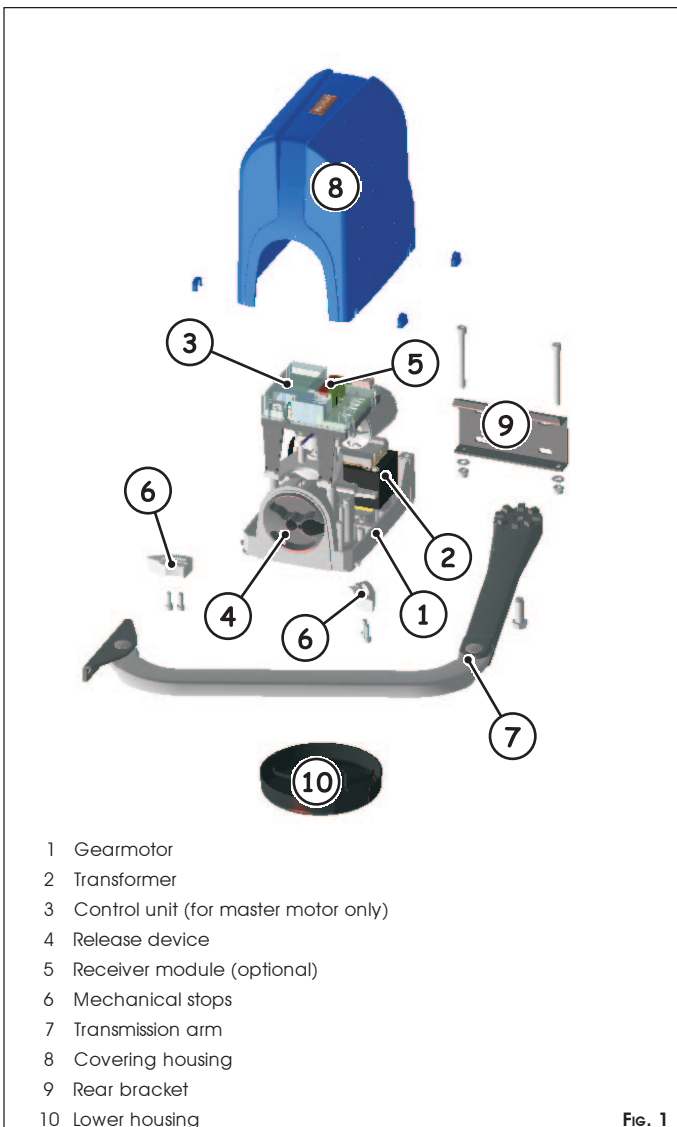
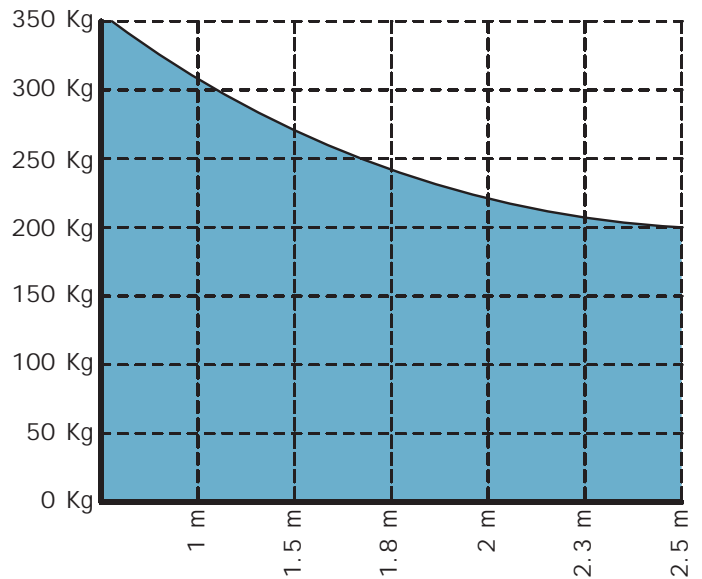

FIG. 1



3. DIMENSIONS

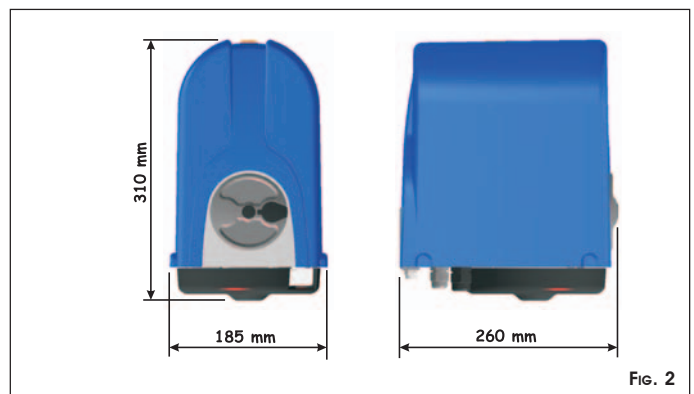
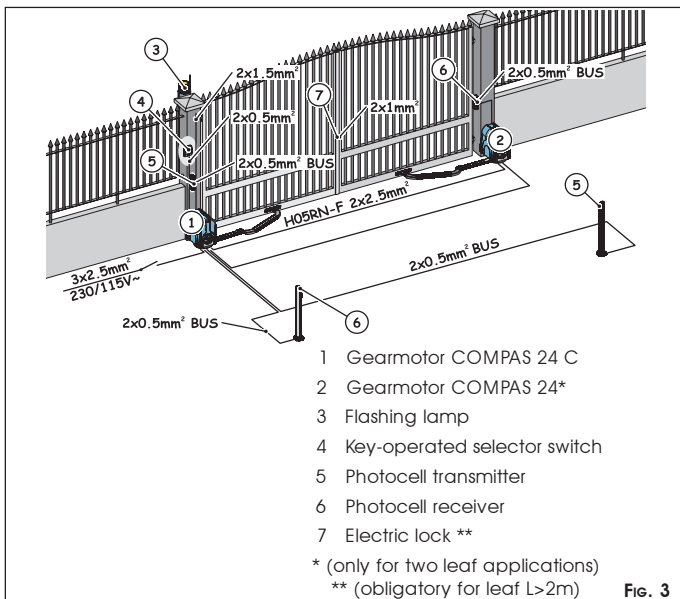

FIG. 2

4. ELECTRICAL CONNECTIONS

- The lay-out below refers to an installation with two motors, with all safety and signalling devices connected.
- For two-motor applications, use a cable, type **H05RN-F** to connect the MASTER and SLAVE operators.



5. INSTALLATION

5.1. PRELIMINARY CHECKS

To ensure a correctly operating automated system, the structure of the gate to be moved must satisfy the following requirements:

- The mechanical construction elements must comply with the provisions of the EN12604 and EN 12605 standards.
- leaf length must conform to the operator characteristics (see paragraph 2)
- sturdy, rigid gate structure, suitable for the automated system
- smooth, uniform gate movement, without any friction and jamming during the entire opening;
- adequately sturdy hinges, in good condition
- an efficient earth socket for connection of the operator

We advise you to carry out the metalwork jobs if any, before installing the automated system.

- The condition of the gate structure directly influences the reliability and safety of the automated system.**
- If the leaf to be motorised incorporates a door for the pedestrian passage it is compulsory to add a safety switch on the door, connected to the stop input, in order to inhibit the operation of the automated system when the door is open.**
- The gearmotor cannot be used to move safety exits or gates fitted on emergency routes (escape routes).**

5.2 INSTALLATION DIMENSIONS

Procedure for finding the securing position of the operator, using Fig.4 to help you:

- measure dimension "A" of the gate and trace a horizontal line on the graph on the measured value, this line to cross the whole graph.
- you will obtain the maximum permissible angular opening according to dimension "A" of the graph.
- select the opening range you require
- select dimension "B" so that it intersects the horizontal line (dimension "A") inside the required opening range.
- If dimension "A" permits opening values greater than the opening value selected, the value of dimension "B" can change up to the maximum permissible opening value.**
- Make sure that the minimum dimension of 450mm in Fig.4 is observed.**
- When the operator has been installed, check if dimension "X" in Fig.4 is minimum 500 mm. If dimension**

"X" is less than 500mm, run an impact test on the point indicated in Fig.4, as described in UNI EN12445 standard, and make sure that the measured values conform to the specifications of UNI EN 12453 standard.

- If the thrust values are not within the values specified in UNI EN12453 standard, the zone indicated in figure 4 **MUST** be protected with a protective device conforming to the UNI EN12978 standard.

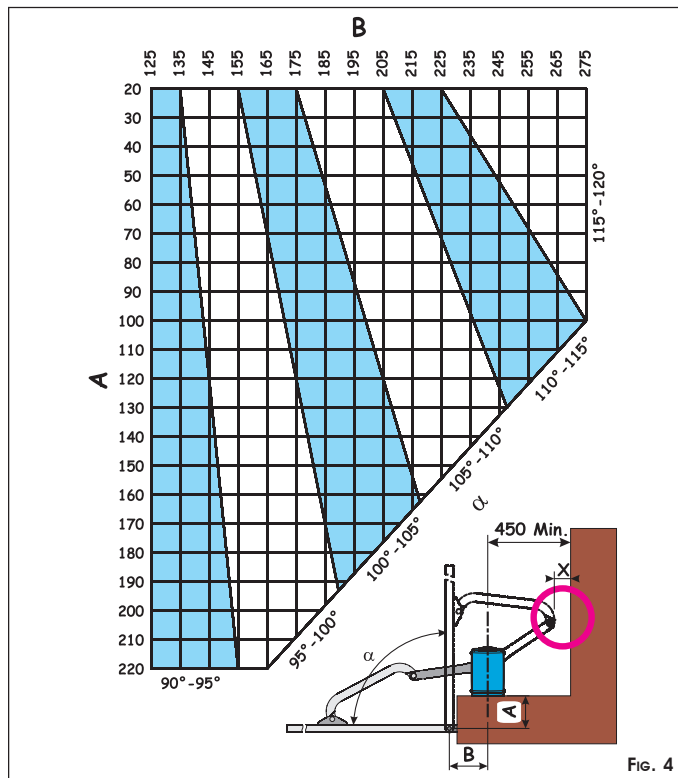

- The operator was studied and made to be secured vertically (Fig.5). The operator cannot be installed in other positions.



5.3. INSTALLING THE OPERATOR

When you have established dimensions "A" and "B", you can install the operator as follows:

- Loosen by about 1/2 turn the four securing screws of the upper housing (Fig.6 ref.①) and withdraw the housing. Set the operator for manual operation, see paragraph 7.

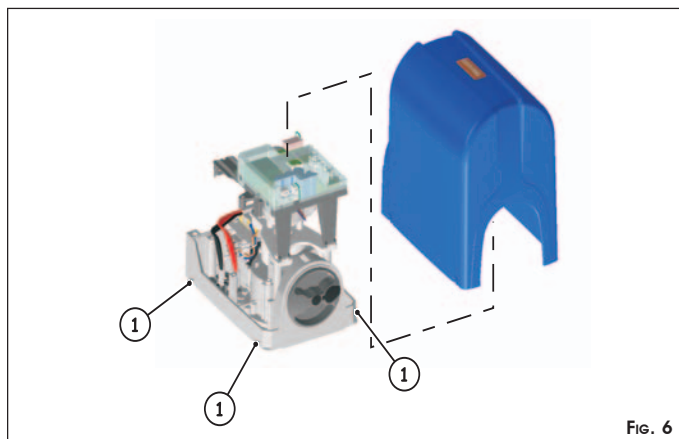

- ② Establish the height of the operator, bearing in mind that:
- the securing bracket of the curved arm must be in a zone where it can be secured to the gate leaf (Fig.7)
 - the minimum off ground height of the operator must permit securing the curved arm and positioning the lower housing (at least 85mm, see fig.7).

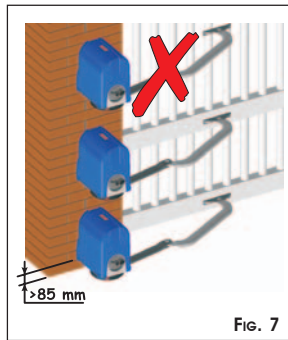

Fig. 7

- the lower edge of the rear bracket must be aligned with respect to the upper edge of the front bracket (Fig.8).

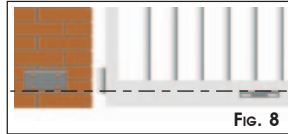

Fig. 8

- ③ Secure the rear bracket in the position you had established, using four M8 screws. As you secure the bracket, respect the lay-out in Fig. 9 and check, using a level, if the bracket is horizontal.

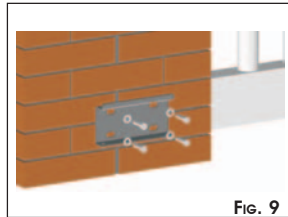

Fig. 9



- To improve water tightness, the external housing covers the securing bracket - this prevents the bracket from being directly welded on the pilaster.
- The rear bracket must be secured on an as smooth as possible surface. For masonry pilasters, a counter-plate for walling is available as an accessory.

- ④ Position the operator on the bracket you have just secured, using two M8x100 screws and the relevant nuts - supplied (Fig.10).
- ⑤ Set the operator for manual operation, see paragraph 7.

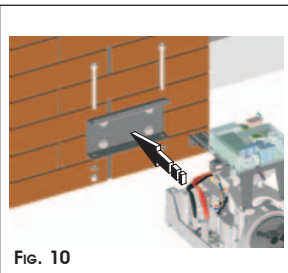

Fig. 10

- ⑥ Install the straight arm (Fig.11) with the supplied screw.

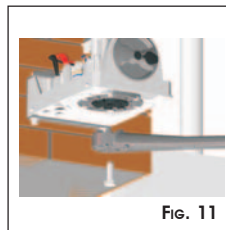

Fig. 11

- ⑦ Assemble the rest of the arm as illustrated in Fig.12.



For correct operation, tighten the two securing screws (Fig.12 ref.①) and then loosen them by about 1/2 turn to enable rotation without any friction on the arms.

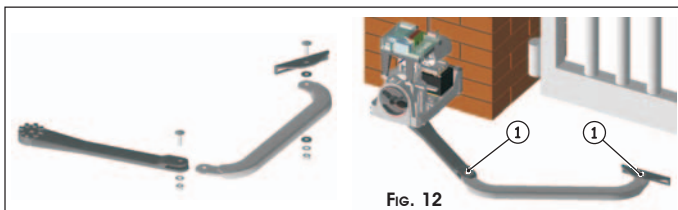

Fig. 12

- ⑧ Align the arms you have just assembled, pushing in the central zone until they stop, see Fig. 13 ref. ①.



There are two stops on the curved arm to facilitate the aligning operation.

- ⑨ Rest the front bracket on the leaf, Fig.13 ref. ②.
- ⑩ Move back the front bracket by about 20 mm and mark the securing holes, Fig. 13 ref. ③.

- ⑪ Secure the bracket in the established position using two M8 screws.

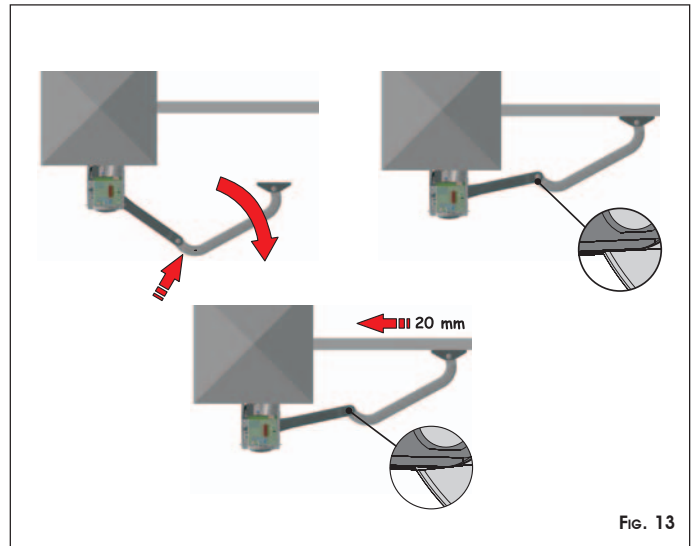

Fig. 13



We advise you to secure the bracket with the screws, and not weld it to the leaf, in order not to rule out future adjustments.

- ⑫ Move the bracket by hand and - with the leaf in closing position - make sure that the two arms do not impact each other, as shown in Fig. 13 ref. ②.
- ⑬ Take the operator back to the work position - see paragraph 7.

5.4. WIRING THE OPERATOR

When you have finished securing the operator, you can wire it. There are three holes in the lower part of the operator. They should be used for positioning the cable grippers, for routing the power cables, for connecting accessories and, if necessary, for connecting the second motor.

- ① Install all the three supplied cable grippers with the securing nuts (Fig. 14).



- Always use the largest cable gripper (Fig.14 ref.①)
- If the other two cable grippers are not used, they must be closed, using the supplied plugs (Fig.14 ref.②). Fit the plastic plug in the cable routing hole and close the cable gripper until it is tight.

- ② Connect the power cable, as shown in Fig.15. The earthing wire must also be connected. Make sure that the power cable wires are correctly fitted in the 'comb' which restrains them Fig. 15.

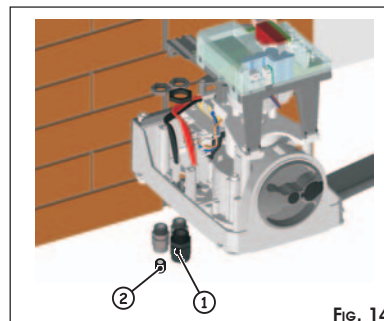

Fig. 14

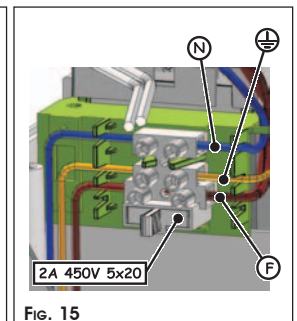

Fig. 15



- If the protective fuse has to be replaced, use a fuse with the following characteristics:
5x20 2A 450V

- ③ Wire all the accessories and safety devices, observing the relevant instructions.

5.5. POSITIONING THE MECHANICAL STOPS

The COMPAS operator is supplied standard with opening and closing mechanical stops. This is to facilitate the installation operations because there is no need to construct the mechanical stop elements. The mechanical stops should be fitted in the lower part of the operator, coupled to a toothed sector. Installation procedure for the stops:

OPENING MECHANICAL STOP

- ① Set the operator for manual operation, see paragraph 7.
- ② Manually move the leaf to its opening position.
- ③ Take the mechanical stop as close as possible to the straight arm and fasten the two securing screws.

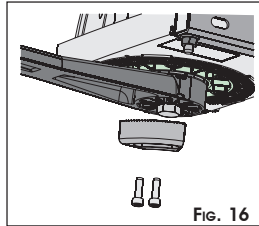

- Make sure that the toothed sector is coupled correctly.

CLOSING MECHANICAL STOP



- Use the closing mechanical stop only in the absence of a mechanical stop on the closing leaf.
- The closing mechanical stop does not guarantee locking the leaf in case of burglary.

- ① Set the operator for manual operation, see paragraph 7.
- ② Manually move the leaf to its closed position.
- ③ Take the mechanical stop as close as possible to the straight arm and fasten the two securing screws.



- Make sure that the toothed sector is coupled correctly.

6. AUTOMATED SYSTEM TEST

- When you have made all the necessary electrical connections, power up the system and program the control unit according to your requirements.
- Run the test for the automation and for all the connected accessories, taking great care when checking the safety devices.
- Re-locate the upper covering housing, tighten the securing screws and position the four covering plugs fig.17 ref. ①.
- Position the lower housing as shown in fig.17 ref. ②.
- Hand the "User's Guide" booklet to the customer and describe its correct operation and use.



- Point out, to the end user, any residual risks present in the installation.

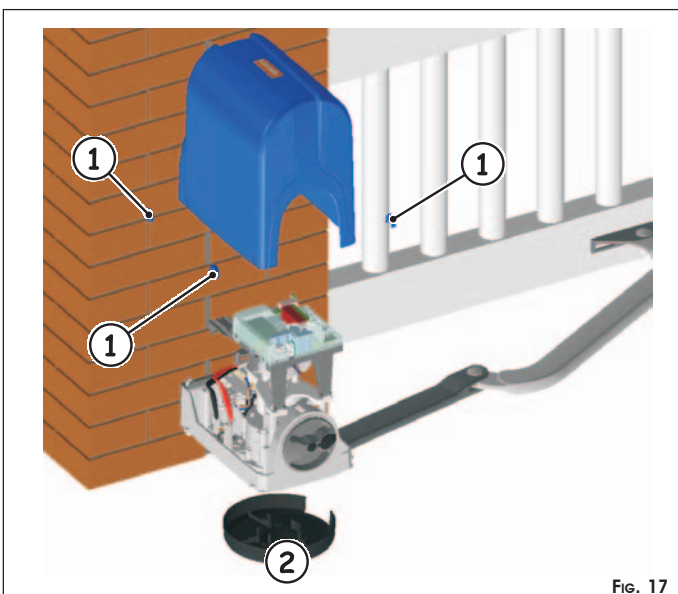

7. MANUAL MODE OPERATION

If the operator has to be manually activated due to a power cut or to an operator fault, proceed as follows:

- ① Cut power to the system with the differential switch.
- ② Lift the protective plug from the lock, fig.18 ref. ①
- ③ Fit the key and turn it anti-clockwise until it stops, fig.18 ref. ②.
- ④ Turn the release knob clockwise until it stops, fig.18 ref. ③.
- ⑤ Move the leaf by hand.

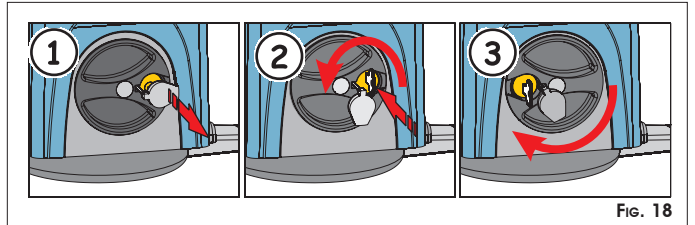

Procedure for restoring normal operation:

- ① Make sure that the system is not powered.
- ② Position the leaf to its closing position.
- ③ Turn the release knob anti-clockwise until it stops, then turn the key clockwise until it stops and remove it.
- ④ Check if the release device has been correctly engaged, by trying to move the leaf by hand. The leaf must be locked and it must not be possible to move it by hand.
- ⑤ Re-position the lock covering plug.
- ⑥ Restore power to the system and command an opening cycle.



- The operator may not correctly execute the decelerations on the first cycle. Wait for the end of the cycle and give another opening command.

8. SPECIAL APPLICATIONS

Applications other than those in this manual are EXPRESSLY PROHIBITED

9. MAINTENANCE

To ensure correct long-term operation and a constant level of safety, we advise you to generally control the system every 6 months. In the "User's Guide" booklet, there is a form for recording jobs.

10. REPAIRS

The User must not in any way attempt to repair or to take direct action and must solely contact qualified GENIUS personnel or GENIUS service centres.

11. ACCESSORIES

For accessories, see the GENIUS catalogue.

- 6) GENIUS declina cualquier responsabilidad derivada de un uso impropio o diverso del previsto.
 - 7) No instalen el aparato en atmósfera explosiva: la presencia de gas o humos inflamables constituye un grave peligro para la seguridad.
 - 8) Los elementos constructivos mecánicos deben estar de acuerdo con lo establecido en las Normas EN 12604 y EN 12605.
- Para los países no pertenecientes a la CEE, además de las referencias normativas nacionales, para obtener un nivel de seguridad adecuado, deben seguirse las Normas arriba indicadas.
- 9) GENIUS no es responsable del incumplimiento de las buenas técnicas de fabricación de los cierres que se han de motorizar, así como de las deformaciones que pudieran intervenir en la utilización.
 - 10) La instalación debe ser realizada de conformidad con las Normas EN 12453 y EN 12445. El nivel de seguridad de la automatización debe ser C+D.
 - 11) Quitar la alimentación eléctrica y desconecten las baterías antes de efectuar cualquier intervención en la instalación.
 - 12) Coloquen en la red de alimentación de la automatización un interruptor onnipolar con distancia de apertura de los contactos igual o superior a 3 mm. Se aconseja usar un magnetotérmico de 6A con interrupción onnipolar.
 - 13) Comprueben que la instalación disponga línea arriba de un interruptor diferencial con umbral de 0,03 A.
 - 14) Verifiquen que la instalación de tierra esté correctamente realizada y conecten las partes metálicas del cierre.
 - 15) La automatización dispone de un dispositivo de seguridad antiaplastamiento constituido por un control de par. No obstante, es necesario comprobar el umbral de intervención según lo previsto en las Normas indicadas en el punto 10.
 - 16) Los dispositivos de seguridad (norma EN 12978) permiten proteger posibles áreas de peligro de **Riesgos mecánicos de movimiento**, como por ej. aplastamiento, arrastre, corte.
 - 17) Para cada equipo se aconseja usar por lo menos una señalización luminosa así como un cartel de señalización adecuadamente fijado a la estructura del bastidor, además de los dispositivos indicados en el "16".
 - 18) GENIUS declina toda responsabilidad relativa a la seguridad y al buen funcionamiento de la automatización si se utilizan componentes de la instalación que no sean de producción GENIUS.
 - 19) Para el mantenimiento utilicen exclusivamente piezas originales GENIUS
 - 20) No efectúen ninguna modificación en los componentes que forman parte del sistema de automatización.
 - 21) El instalador debe proporcionar todas las informaciones relativas al funcionamiento del sistema en caso de emergencia y entregar al usuario del equipo el manual de advertencias que se adjunta al producto.
 - 22) No permitan que niños o personas se detengan en proximidad del producto durante su funcionamiento.
 - 23) Mantengan lejos del alcance los niños los telemandos o cualquier otro emisor de impulso, para evitar que la automatización pueda ser accionada involuntariamente.
 - 24) Ne pas permette aux enfants, aux personnes ayant des capacités physiques, mentales et sensorielles limitées ou dépourvues de l'expérience ou de la formation nécessaires d'utiliser l'application en question.
 - 25) Sólo puede transitarse entre las hojas si la cancela está completamente abierta.
 - 26) El usuario debe abstenerse de intentar reparar o de intervenir directamente, y debe dirigirse exclusivamente a personal cualificado GENIUS o a centros de asistencia GENIUS.
 - 27) Todo lo que no esté previsto expresamente en las presentes instrucciones debe entenderse como no permitido

HINWEISE FÜR DEN INSTALLATIONSTECHNIKER

ALLGEMEINE SICHERHEITSVORSCHRIFTEN

- 1) **ACHTUNG!** Um die Sicherheit von Personen zu gewährleisten, sollte die Anleitung aufmerksam befolgt werden. Eine falsche Installation oder ein fehlerhafter Betrieb des Produktes können zu schwerwiegenden Personenschäden führen.
- 2) Bevor mit der Installation des Produktes begonnen wird, sollten die Anleitungen aufmerksam gelesen werden.
- 3) Das Verpackungsmaterial (Kunststoff, Styropor, usw.) sollte nicht in Reichweite von Kindern aufbewahrt werden, da es eine potentielle Gefahrenquelle darstellt.
- 4) Die Anleitung sollte aufbewahrt werden, um auch in Zukunft Bezug auf sie nehmen zu können.
- 5) Dieses Produkt wurde ausschließlich für den in diesen Unterlagen angegebenen Gebrauch entwickelt und hergestellt. Jeder andere Gebrauch, der nicht ausdrücklich angegeben ist, könnte die Unversehrtheit des Produktes beeinträchtigen und/oder eine Gefahrenquelle darstellen.
- 6) Die Firma GENIUS lehnt jede Haftung für Schäden, die durch unsachgemäßen oder nicht bestimmungsgemäßen Gebrauch der Automatik verursacht werden, ab.
- 7) Das Gerät sollte nicht in explosionsgefährdeten Umgebungen installiert werden: das Vorhandensein von entflammbaren Gasen oder Rauch stellt ein schwerwiegendes Sicherheitsrisiko dar.
- 8) Die mechanischen Bauelemente müssen den Anforderungen der Normen EN 12604 und EN 12605 entsprechen.
Für Länder, die nicht der Europäischen Union angehören, sind für die Gewährleistung eines entsprechenden Sicherheitsniveaus neben den nationalen gesetzlichen Bezugsvorschriften die oben aufgeführten Normen zu beachten.
- 9) Die Firma GENIUS übernimmt keine Haftung im Falle von nicht fachgerechten Ausführungen bei der Herstellung der anzufreibenden Schließvorrichtungen sowie bei Deformationen, die eventuell beim Betrieb entstehen.
- 10) Die Installation muß unter Beachtung der Normen EN 12453 und EN 12445 erfolgen. Die Sicherheitsstufe der Automatik sollte C+D sein.
- 11) Vor der Ausführung jeglicher Eingriffe auf der Anlage sind die elektrische Versorgung und die Batterie abzunehmen.
- 12) Auf dem Versorgungsnetz der Automatik ist ein onnipolarer Schalter mit Öffnungsabstand der Kontakte von über oder gleich 3 mm einzubauen. Darüber hinaus wird der Einsatz eines Magnetschutzschalters mit 6A mit onnipolarer Abschaltung empfohlen.
- 13) Es sollte überprüft werden, ob vor der Anlage ein Differentialschalter mit einer Auslöseschwelle von 0,03 A zwischengeschaltet ist.
- 14) Es sollte überprüft werden, ob die Erdungsanlage fachgerecht ausgeführt wurde. Die Metallteile der Schließung sollten an diese Anlage angeschlossen werden.
- 15) Die Automation verfügt über eine eingebaute Sicherheitsvorrichtung für den Quetschschutz, die aus einer Drehmomentkontrolle besteht. Es ist in jedem Falle erforderlich, deren Eingriffschwelle gemäß der Vorgaben der unter Punkt 10 angegebenen Vorschriften zu überprüfen.
- 16) Die Sicherheitsvorrichtungen (Norm EN 12978) ermöglichen den Schutz eventueller Gefahrenbereiche vor **mechanischen Bewegungsrisiken**, wie zum Beispiel Quetschungen, Mitschleifen oder Schnittverletzungen.

- 17) Für jede Anlage wird der Einsatz von mindestens einem Leuchtsignal empfohlen sowie eines Hinweisschildes, das über eine entsprechende Befestigung mit dem Aufbau des Tors verbunden wird. Darüber hinaus sind die unter Punkt "16" erwähnten Vorrichtungen einzusetzen.
- 18) Die Firma GENIUS lehnt jede Haftung hinsichtlich der Sicherheit und des störungsfreien Betriebs der Automatik ab, soweit Komponenten auf der Anlage eingesetzt werden, die nicht im Hause GENIUS hergestellt wurden.
- 19) Bei der Instandhaltung sollten ausschließlich Originalteile der Firma GENIUS verwendet werden.
- 20) Auf den Komponenten, die Teil des Automationssystems sind, sollten keine Veränderungen vorgenommen werden.
- 21) Der Installateur sollte alle Informationen hinsichtlich des manuellen Betriebs des Systems in Notfällen liefern und dem Betreiber der Anlage das Anleitungsbuch, das dem Produkt beigelegt ist, übergeben.
- 22) Weder Kinder noch Erwachsene sollten sich während des Betriebs in der unmittelbaren Nähe der Automation aufhalten.
- 23) Die Funksteuerungen und alle anderen Impulsgeber sollten außerhalb der Reichweite von Kindern aufbewahrt werden, um ein versehentliches Aktivieren der Automation zu vermeiden.
- 24) Die Anwendung darf nicht von Kindern, von Personen mit verminderter körperlicher, geistiger, sensorielle Fähigkeit oder Personen ohne Erfahrungen oder der erforderlichen Ausbildung verwendet werden.
- 25) Der Durchgang oder die Durchfahrt zwischen den Flügeln darf lediglich bei vollständig geöffnetem Tor erfolgen.
- 26) Der Benutzer darf direkt keine Versuche für Reparaturen oder Arbeiten vornehmen und hat sich ausschließlich an qualifiziertes Fachpersonal GENIUS oder an Kundendienstzentren GENIUS zu wenden.
- 27) Alle Vorgehensweisen, die nicht ausdrücklich in der vorliegenden Anleitung vorgesehen sind, sind nicht zulässig

WAARSCHUWINGEN VOOR DE INSTALLATEUR

ALGEMENE VEILIGHEIDSVOORSCHRIFTEN

- 1) **LET OPI!** Het is belangrijk voor de veiligheid dat deze hele instructie zorgvuldig wordt opgevolgd. Een onjuiste installatie of foutief gebruik van het product kunnen ernstig persoonlijk letsel veroorzaken.
- 2) Lees de instructies aandachtig door alvorens te beginnen met de installatie van het product.
- 3) De verpakkingsmaterialen (plastic, polystyreen, enz.) mogen niet binnen het bereik van kinderen worden gelaten, want zij vormen een mogelijke bron van gevaar.
- 4) Bewaar de instructies voor raadpleging in de toekomst.
- 5) Dit product is uitsluitend ontworpen en gebouwd voor het doel dat in deze documentatie wordt aangegeven. Elk ander gebruik, dat niet uitdrukkelijk wordt vermeld, zou het product kunnen beschadigen en/of een bron van gevaar kunnen vormen.
- 6) GENIUS aanvaardt geen enkele aansprakelijkheid voor schade die ontstaat uit oneigenlijk gebruik of ander gebruik dan waarvoor het automatische systeem is bedoeld.
- 7) Installeer het apparaat niet in een explosiegevaarlijke omgeving: de aanwezigheid van ontvlambare gassen of dampen vormt een ernstig gevaar voor de veiligheid.
- 8) De mechanische bouwelementen moeten in overeenstemming zijn met de bepalingen van de normen EN 12604 en EN 12605.
Voor niet-EEG landen moeten, om een goed veiligheidsniveau te bereiken, behalve de nationale voorschriften ook de bovenstaande normen in acht worden genomen.
- 9) GENIUS is niet aansprakelijk als de regels der goede techniek niet in acht genomen zijn bij de bouw van het sluitwerk dat gemotoriseerd moet worden, noch voor vervormingen die zouden kunnen ontstaan bij het gebruik.
- 10) De installatie dient te geschieden in overeenstemming met de normen EN 12453 en EN 12445. Het veiligheidsniveau van het automatische systeem moet C+D zijn.
- 11) Alvorens ingrepen te gaan verrichten op de installatie moet de elektrische voeding worden weggenomen en moeten de batterijen worden afgekoppeld.
- 12) Zorg op het voedingsnet van het automatische systeem voor een meerpolige schakelaar met een opening tussen de contacten van 3 mm of meer. Het wordt geadviseerd een magnetothermische schakelaar van 6A te gebruiken met meerpolige onderbreking.
- 13) Controleer of er bovenstrooms van de installatie een differentieelschakelaar is geplaatst met een limiet van 0,03 A.
- 14) Controleer of de aardingsinstallatie vakkundig is aangelegd en sluit er de metalen delen van het sluitsysteem op aan.
- 15) Het automatische systeem beschikt over een intrinsieke beveiliging tegen inklemming, bestaande uit een controle van het koppel. De inschakellimiet hiervan dient echter te worden gecontroleerd volgens de bepalingen van de normen die worden vermeld onder punt 10.
- 16) De veiligheidsvoorzieningen (norm EN 12978) maken het mogelijk eventuele gevaarlijke gebieden te beschermen tegen **Mechanische gevaren door beweging**, zoals bijvoorbeeld inklemming, meesleuren of amputatie.
- 17) Het wordt voor elke installatie geadviseerd minstens één lichtsignaal te gebruiken alsook een waarschuwingbord dat goed op de constructie van het hang- en sluitwerk dient te worden bevestigd, afgezien nog van de voorzieningen die genoemd zijn onder punt "16".
- 18) GENIUS aanvaardt geen enkele aansprakelijkheid voor wat betreft de veiligheid en de goede werking van het automatische systeem, als er in de installatie gebruik gemaakt wordt van componenten die niet door GENIUS zijn geproduceerd.
- 19) Gebruik voor het onderhoud uitsluitend originele GENIUS-onderdelen.
- 20) Verricht geen wijzigingen op componenten die deel uitmaken van het automatische systeem.
- 21) De installateur dient alle informatie te verstrekken over de handbediening van het systeem in noodgevallen, en moet de gebruiker van de installatie het bij het product geleverde boekje met aanwijzingen overhandigen.
- 22) Sta het niet toe dat kinderen of volwassenen zich ophouden in de buurt van het product terwijl dit in werking is.
- 23) Houd radio-afstandsbedieningen of alle andere impulsgevers buiten het bereik van kinderen, om te voorkomen dat het automatische systeem onopzettelijk kan worden aangedreven.
- 24) De toepassing mag niet worden gebruikt door kinderen, personen met lichamelijke, geestelijke en sensoriele beperkingen, of door personen zonder ervaring of de benodigde training.
- 25) Ga alleen tussen de vleugels door als het hek helemaal geopend is.
- 26) De gebruiker mag zelf geen pogingen ondernemen tot reparaties of andere directe ingrepen, en dient zich uitsluitend te wenden tot gekwalificeerd en geautoriseerd GENIUS-personeel of een erkend GENIUS-servicecentrum.
- 27) Alles wat niet uitdrukkelijk in deze instructies wordt aangegeven, is niet toegestaan

Le descrizioni e le illustrazioni del presente manuale non sono impegnative. GENIUS si riserva il diritto, lasciando inalterate le caratteristiche essenziali dell'apparecchiatura, di apportare in qualunque momento e senza impegnarsi ad aggiornare la presente pubblicazione, le modifiche che essa ritiene convenienti per miglioramenti tecnici o per qualsiasi altra esigenza di carattere costruttivo o commerciale.

The descriptions and illustrations contained in the present manual are not binding. GENIUS reserves the right, while leaving the main features of the equipments unaltered, to undertake any modifications to holds necessary for either technical or commercial reasons, at any time and without revising the present publication.

Les descriptions et les illustrations du présent manuel sont fournies à titre indicatif. GENIUS se réserve le droit d'apporter à tout moment les modifications qu'elle jugera utiles sur ce produit tout en conservant les caractéristiques essentielles, sans devoir pour autant mettre à jour cette publication.

Las descripciones y las ilustraciones de este manual no comportan compromiso alguno. GENIUS se reserva el derecho, dejando inmutadas las características esenciales de los aparatos, de aportar, en cualquier momento y sin comprometerse a poner al día la presente publicación, todas las modificaciones que considere oportunas para el perfeccionamiento técnico o para cualquier otro tipo de exigencia de carácter constructivo o comercial.

Die Beschreibungen und Abbildungen in vorliegendem Handbuch sind unverbindlich. GENIUS behält sich das Recht vor, ohne die wesentlichen Eigenschaften dieses Gerätes zu verändern und ohne Verbindlichkeiten in Bezug auf die Neufassung der vorliegenden Anleitungen, technisch bzw. konstruktiv / kommerziell bedingte Verbesserungen vorzunehmen.

De beschrijvingen in deze handleiding zijn niet bindend. GENIUS behoudt zich het recht voor op elk willekeurig moment de veranderingen aan te brengen die het bedrijf nuttig acht met het oog op technische verbeteringen of alle mogelijke andere productie- of commerciële eisen, waarbij de fundamentele eigenschappen van het apparaat gehandhaafd blijven, zonder zich daardoor te verplichten deze publicatie bij te werken.

Timbro rivenditore: / Distributor's stamp: / Timbre de l'agent: /
Sello del revendedor: / Fachhändlerstempel: / Stempel dealer:

GENIUS S.p.A.
Via Padre Elzi, 32
24050 - Grassobbio
BERGAMO-ITALY
tel. 0039.035.4242511
fax. 0039.035.4242600
info@geniusg.com
www.geniusg.com

