

ICP-MAP0010 MAP LSN Gateway

Modular Alarm Platform 5000



Each LSN gateway module connects one Local Security Network (LSN) loop or one or two stubs at a maximum output current of 300 mA. Each module supports up to 127 LSN devices. The Modular Alarm Platform 5000 system supports up to eight LSN gateways modules on the internal and external Bosch Data Bus (BDB) and supports up to a maximum of 1500 addresses.

Functions

Fault Tolerance

The design for the loop circuit configuration tolerates a single short or a single open condition and still maintains full operation for all devices on the LSN loop.

Automatic Addressing

On one stub, both LSN classic mode and LSNi mode of devices are supported simultaneously, and unique address is automatically assigned to each device.

Remote Programming Software

Installers can use Remote Programming Software for MAP (RPS for MAP) to check and modify the configuration of devices on the module.

LSN Auxiliary Power Outputs

The module supports two individually over-current protected and supervised outputs.

Firmware upgrades

The firmware of all devices in the MAP system can be upgraded or updated with Remote Programming Software for MAP (RPS for MAP). This allows for on-site or off-site (IP through Ethernet) upgrades or updates.

- ▶ Supports up to 127 LSN devices with a maximum LSN loop current up to 300 mA
- ▶ Provides flexible network structures (one loop or up to two stubs)
- ▶ Provides single fault redundancy on loop configurations (not on stub configurations)
- ▶ Provides two auxiliary power outputs (500 mA each)

Regulatory information

Region	Regulatory compliance/quality marks	
Europe	CE	
	EN50131	Grade 3
Germany	VdS	G111040 Class C
	VdS	G114801 Class C MAP 5000 COM
	VdS-S	S 112016
Great Britain	UKCA	

Installation/configuration notes

Terminals and Connectors

The module is included in a plastic enclosure. The terminal blocks and system connectors are accessible without removing the plastic cover or base.

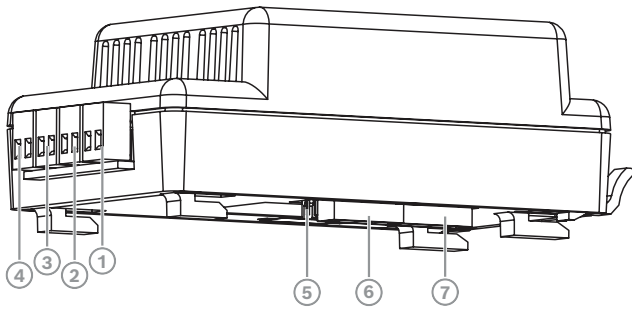

Callout	Description
1	LSN1 AUX power
2	LSN1 LSN data bus
3	LSN2 AUX power
4	LSN2 LSN data bus
5	Tamper input - currently not enabled
6	Bosch Data Bus (BDB) connector (B)
7	Bosch Data Bus (BDB) connector (A)

Connectable LSN devices

The module supports mixed operation of LSN classic devices and LSNi devices on the loop or stub(s).

Motion detectors

DS 840	Dual P.I.R. + MW Motion Detector
DS 935	P.I.R. Motion Detector
IR 200	P.I.R. Motion Detector
IR 210/212	P.I.R. Motion Detector/Curtain Detector
IR 250/252 T	P.I.R. Motion Detector/ Curtain Detector with Anti-mask
IR 270 T	P.I.R. Motion Detector with Anti-mask
PPR1-WA16KV	Professional Series P.I.R Motion Detector with Anti-mask
PDL1-WA18KV	Professional Series Dual P.I.R + MW Motion Detector with Anti-mask
PDL1-WAC25	Professional Series Dual P.I.R + MW Curtain Detector with Anti-mask
PDL2-A12xL	Professional Series Dual P.I.R + MW Motion Detector with Anti-mask
UP 350 T	Dual P.I.R. + US Motion Detector with Anti-mask
UP 370 T	Dual P.I.R. + US Motion Detector with Anti-mask

Contacts

EMK 36 / AMK 4	Magnetic contact
EMK 36 S / AMK 4S	Magnetic contact / window contact with tamper supervision
SKA / SKI 100	Bolt contact indoor / outdoor

Glassbreak detectors

GBS 2036	Passive glassbreak detector
GBD2-110	Passive glassbreak detector

Seismic detectors

GM 570	Seismic detector
GM 580	Seismic detector waterproof
NKS 100	Seismic detector
SM 90-120	Seismic detector

Panic buttons

ND 100	Panic button
ND 200	Panic button

Arming / blocking devices

SE 50	Smartkey blocking device
SE 60	Smartkey blocking device
SE 100/110	Smartkey arming device
SE 120	Smartkey arming device
SE 200/210	Smartkey arming device with PIN pad
SE 220	Smartkey arming device with PIN pad
SE 310	Smartkey arming device with PIN pad + door opener
SE 320	Smartkey arming device with PIN pad + door opener

Fire devices

DM / SM 210	Manual call point
FMC 210/420	Manual call point
FAP-O 420	Optical smoke detector
FAP-425-O	Optical smoke detector
FAP-OT 420	Optical / thermal detector

FAP-425-OT	Optical / thermal detector
FAP-OTC 420	Optical / thermal / chemical detector
FAH-T 420	Thermal detector
FAH-425-T	Thermal detector
O 400	Optical smoke detector
OT 400	Optical / thermal detector
OC 410	Optical / chemical detector
OTC 410	Optical / thermal / chemical detector
T 400	Thermal detector
FAP-O 500	Optical smoke detector
FAP-O 520	Optical smoke detector
FAP-OC 500	Optical / chemical detector
FAP-OC 520	Optical / chemical detector

Sirens and strobes

FNM-420-A/B	Stand-alone sounder indoor/outdoor
FNM-420-A-BS	Base sounder indoor
FNM-420U-A/B	Stand-alone sounder indoor/outdoor uninterruptible
FNM-420U-A-BS	Base sounder indoor uninterruptible
FLM-420-NAC	Signaling device interface module
FNS-420 R	Strobe red

In/out expansion modules

ATB100, ATG100, ATE100, ATB420, ATG420	Indicator module (32 LED)
EM 55-120	Expansion module (2 PL)
EMIL 120	Expansion module (6 PL + 4 OUT)
FLM-420 I8R1	Octo input interface module (8 IN + 1 RELAY)
FLM-420 O8I2	Octo output interface module (8 OUT + 2 IN)
FLM-420 RHV	Relay high voltage interface module

FLM-420 RLV8	Octo relay interface module (8 OUT)
IC 400	Universal expander module (1 PL + 2 OUT)
IF 100/102	16 zone expander module (16 PL + 8 OUT)
KD 55 / KD 55-1	2 zone expander module (2 PL)
NKK 100	Contact interface module (8 IN)
NNK 110	Expansion module (4 PL + 1 IN)
NTK 100	Indicator tableau expansion module (8 OUT + 1 IN)
NVK 100	Expansion module (6 PL + 4 OUT)

Miscellaneous devices

NEV 300	Power supply
---------	--------------

Parts included

Quantity	Component
1	ICP-MAP0010 LSN gateway module
1	Accessory pack <ul style="list-style-type: none"> BDB cable Terminal plugs (2 brown, 2 white)
1	Datasheet

Technical specifications**Electrical**

Operating voltage (VDC)	16 VDC – 29 VDC
Nominal voltage (VDC)	28 VDC
Input current (mA)	0 mA – 1,500 mA
Nominal current (mA)	75 mA
Maximum LSN line current (mA)	300 mA
Maximum LSN AUX output current (mA)	2 x 500 mA

Mechanical

Dimensions (H x W x D) (mm)	158.80 mm x 82.60 mm x 63.50 mm
Weight (g)	365 g

Material	Plastic
Color	White
LED color	Green
Wire requirements	0.6 mm - 1.0 mm (18 AWG - 22 AWG) solid or stranded; up to 1000 m line length; twisted type shielded

Environmental

Operating temperature (°C)	-10 °C – 55 °C
Storage temperature (°C)	-20 °C – 60 °C
Operating relative humidity, non-condensing (%)	5% – 95%
IP rating	IP30
Impact protection	IK04
Environmental class (EN 50130-5)	II
Environmental class (VdS 2110)	II
Usage	Indoor

Ordering information

ICP-MAP0010 MAP LSN Gateway

Supports up to 127 LSN devices. Up to eight gateways can be supported by a Modular Alarm Platform 5000 system.

Order number **ICP-MAP0010 | F.01U.064.521**
F.01U.422.425

Accessories

IPP-MAP0005-2 MAP Power supply, 150W

Power supply and battery charger unit; converts 230 VAC input into 24 VDC nominal and 28 VDC fixed output.

Order number **IPP-MAP0005-2 | F.01U.245.558**
F.01U.423.904

ICP-MAP0120 MAP Expansion enclosure

Contains one MAP Expansion Enclosure, one MAP Expansion Enclosure Tamper Switch, one MAP Enclosure Lockset, and one MAP AC Terminal Block.

Order number **ICP-MAP0120 | F.01U.126.316**

Services

EWE-MAPLSN-IW 12 mths wrty ext MAP LSN gateway

12 months warranty extension

Order number **EWE-MAPLSN-IW**

Represented by:

Europe, Middle East, Africa:
 Bosch Security Systems B.V.
 P.O. Box 80002
 5600 JB Eindhoven, The Netherlands
www.boschsecurity.com/xc/en/contact/
www.boschsecurity.com

Germany:
 Bosch Sicherheitssysteme GmbH
 Robert-Bosch-Platz 1
 D-70839 Gerlingen
www.boschsecurity.com

North America:
 Bosch Security Systems, LLC
 130 Perinton Parkway
 Fairport, New York, 14450, USA
www.boschsecurity.com

Asia-Pacific:
 Robert Bosch (SEA) Pte Ltd, Security Systems
 11 Bishan Street 21
 Singapore 573943
www.boschsecurity.com/xc/en/contact/
www.boschsecurity.com