

Elmdene International Ltd
3 Keel Close, Interchange Park,
Portsmouth, Hampshire, PO3 5QD, UK

Tel: +44(0)23 9269 6638
Fax: +44(0)23 9266 0483
Web: www.elmdene.co.uk

27.6 Vdc 5 Amp Switch Mode Power Supply for Fire – EN54-4:1997 +A1 +A2

STX2405-E

STX2405-C

FEATURES

The STX2405-x is an EN54-4:1997 +A1 +A2 approved power supply ideal for use in Fire and Smoke and ventilation control Systems. Its regulated 27.6V dc output will supply up to 5 Amps continuous into the load, in addition to providing up to 850mA for charging the standby batteries up to 17Ah. The power supply output features electronic short circuit protection under both mains and standby battery operation. Maximum battery life is assured through continuous active battery monitoring and the use of a two stage charger, comprising bulk and temperature compensated final float phase depending upon battery condition. Once fully charged the product operates in Eco power saving mode, whereby the batteries are charged for 4 hours in every 24 hour period while still being continuously monitored. This reduces wasted energy in charging already fully charged batteries and extends their working life. Deep discharge protection prevents premature battery failure when operating from standby for extended periods. Two sets of volt free solid state relay fault output signal (i) loss of mains and (ii) battery fault, charger fault and loss of output. In addition there is an optional plug in serial interface that can provide diagnostic and fault reporting information to supervisory systems.

- Certified by UL to EN54-4:1997 +A1 +A2.
- Up to 5A current to load at 27.6V dc nominal regulated output.
- Charging capability to support 7 or 17/18Ah batteries.
- Electronic overload protection shuts down output until overload or short circuit is removed.
- Battery Monitor detects battery missing, low battery, short-circuit or reverse connection or circuit impedance (Ri) in excess of 500mΩ caused by connector or wiring corrosion within 4hours.
- Battery charging circuit is energised only when a battery is correctly connected and the battery voltage is greater than 14 V.
- No loss of output during automatic connection of battery to load on loss of mains.
- Deep discharge protection disconnects battery from load when battery voltage falls below 21 V.
- Diagnostic indicator LED (Orange) (Internal).
- Fault indicator LED (Yellow) flashes on detection of output fault, battery fault, charger fault and mains failure.
- Mains indicator LED (Green) showing mains present Indicators check at start-up.
- Optional RS232 serial interface for fault reporting and diagnostics.

SPECIFICATION
Mains Input

Rated Voltage (Operational voltage)	110 – 240 Vac (90 – 264 Vac)
Frequency	50 Hz
Input current	< 2.0 Amps at full load
Inrush current	25 A Max at 25 °C 110 Vac for 10ms
Fuse	T3.15 A, 20 mm, 250 Vac HRC

Output

Voltage at full load Mains power Battery standby	27.0 – 28.3V dc (range) (27.6V nominal) 20.3 – 26.0V dc		
Ripple	<100 mV pk – pk max @ Rated Voltage		
Fuse Load Battery	F5.0 A F5.0 A		
Battery mode selected	2.1 Ah	7 Ah	17/18 Ah
Continuous Output Current No charging (Imax B) With charging (Imax A)	5.0 A 5.0 A	5.0 A 5.0 A	5.0 A 5.0 A
Battery Capacity eg - PowerSonic model - Yuasa model - Interlogix model	2 x 2.1 Ah 12 V PS12021 NP2.1-12	2 x 7 Ah 12 V PS12070 NP7-12	2 x 17/18 Ah 12 V PS12170 NP17-12 BS131N
Battery Charging	Constant current bulk charging to 80% capacity within 24 hours Float charging to 100% within 48 hours Eco charging and check every 24 hours – (for up to 8 hours pulse charge dependent on temperature)		
Constant current charge	0.8 A		
Low battery threshold voltage	23 V		
Deep discharge protection	Threshold voltage – 21 V		
Quiescent current – no load	< 30 mA @ 27.6 V		
Quiescent current – batt cut off	< 1 mA @ 27.6 V		

Mechanical

Product Reference	STX2405-C	STX2405-E
Enclosure Dimensions w x h x d (mm)	275 x 330 x 80	400 x 420 x 80
Weight (kg) excluding battery	3.7 Kg	5.9 Kg
Material	1.2mm steel white powder coated	

Environmental

Temperature – Operating	-10 to +40°C (operating) 75% RH non-condensing
Temperature - Storage	-20 to +80°C (storage)

Connections and Signalling outputs

Load Output +/-	Screw terminals Voltage output to load
GEN PSU Fault (normally closed contact)	0.10 A @ 60 Vdc 16Ω solid state relay contacts, volt free Open if Mains failed and battery voltage < 23 V or fault PSU fault condition, (see below)
EPS Fault (normally closed contact)	0.10 A @ 60 Vdc 16Ω solid state relay contacts, volt free Open if loss of mains for > 10 seconds
Temperature sensor	Thermistor input from supplied battery terminal thermistor.
BATT +/-	Connection to back up battery using supplied battery lead
Optional Serial interface	5 pin header TTL Serial interface

SIGNALLING AND DIAGNOSTICS

Fault Outputs

EPS Fault	GEN Fault	Condition	Possible Cause	Action
CLOSED	CLOSED	Normal operation	Mains present Battery healthy	None (No fault)
OPEN	CLOSED	Standby Mode	Mains lost Battery driving load	Investigate loss of mains
CLOSED	OPEN	Fault Present	Blown fuses Battery fault Internal fault	Investigate fault source using diagnostic LED Rectify fault where possible
OPEN	OPEN	PSU Shutdown	Mains lost Standby battery exhausted	Restore mains as soon as possible

LED Indication

LED type	Function
Yellow LED	Fault Indicator (See 'Fault Diagnostic table' User and Engineer)
Green LED	Mains supply On Indicator
Orange LED	Diagnostic Indicator (Not visible through front panel)

Fault Diagnostic table – Front panel - User

Yellow LED Fault	Green LED Mains	Condition	Possible Cause	Action
OFF	ON	Normal operation	Mains present Battery healthy	None (No fault)
FLASH CONTINUOUS	ON or OFF	Fault	Blown fuses Battery fault Internal fault	Contact service engineer
1 PULSE/S	OFF	Standby Mode	Mains lost Battery driving load	Investigate loss of mains

Fault Diagnostic table – Internal - Engineer

Orange LED Diagnostic	Green LED Mains	Condition	Possible Cause	Action
OFF	ON	Normal operation	Mains present Battery fully charged	None (No fault)
	OFF	Standby Operation	Mains Lost. No faults present Battery driving load	Investigate loss of mains
FLASH CONTINUOUS	ON or OFF	No output	Output fuse blown Output overload Output short circuit	Check and replace output fuse Disconnect output load and test load
1 PULSE	ON	Battery Charging	No faults active Battery charging normally but < 90% of full charge	None (No fault)
2 PULSES	ON	No Battery	Battery disconnected Battery fuse blown Battery heavily discharged	Check battery connections Check battery fuse Check battery condition Replace battery if aged
	OFF	Low Battery Volts	Standby Mode Battery almost discharged	Restore mains
3 PULSES	ON or OFF	Battery Fault	High impedance in battery connection Battery internal fault	Check battery connections for corrosion. Replace battery if aged
4 PULSES	ON or OFF	Charger Fault	Internal failure of battery charger	Return to manufacturer
5 PULSES	ON or OFF	Battery Temperature Probe Fault	Battery temperature monitor disconnected or damaged PSU running in Safe Mode	Check temperature sensor connections and condition of sensor. Replace if suspect

INSTALLATION

This Power Supply Unit (PSU) is only suitable for installation as permanently connected equipment (Power Supply Equipment / PSE). The PSE is NOT SUITABLE for external installation. This product is designed for the use in automatic fire detection and fire alarm systems. If the PSE is used as a power supply for Control and Indicating Equipment (CIE), the PSE shall be installed no further than 10cm from the CIE, and close coupled by conduit. This unit must be fed from a mains power source having a separate (approved) disconnect device and fitted with a fuse or other over-current protection device rated at 5 A maximum. Ensure that the disconnect device used has appropriate earth fault protection to the applicable standard.

Where the PSE is used to provide power to a fire alarm circuit, the mains isolation and disconnect device should be provided solely for this purpose and be suitably marked “FIRE ALARM – DO NOT TURN OFF”. All cabling should meet national and local fire system installation regulations, e.g. FP200 type cable for high integrity installations.

Where the PSE is used for other applications, it should be installed according to all relevant safety regulations applicable to that application.

Where the GEN PSU Fault and EPS Fault outputs are used, they should only be connected to circuits having voltages less than 60 Vdc.

Cable Sizing

- 1) Mains input cable must be to the applicable standard with a 5 A or greater current capacity, i.e. 0.75 mm² nominal conductor area, having a minimum operating voltage of 300/500 Vac.
- 2) The low voltage output cable must be sized to carry the rated load current to the devices connected to the PSE, at full 5 Amp load this should be 1.5 mm² CSA.
- 3) Mains input and low voltage output cables should be routed to use different entry / exit holes in the case. Bushes should be used to protect cable sheaths from chafing. Ensure that these bushes are correctly sized (i.e. close fitting with respect to cable sizing). Note that the bushes should meet a minimum flammability specification of UL94 HB.
- 4) All cabling should be securely fastened in position using a cable tie through the saddles provided.

Mounting – C Box – 7 Ah

- 5) The C box is designed to support two 7 Ah batteries, and as such weighs a total of 9 Kg when loaded. Ensure that wall fixings are appropriate to support this weight.

Mounting – E box – 17 or 18 Ah

- 6) The E box is designed to support two support two 17 or 18 Ah batteries, and as such weighs 18.5 Kg when loaded. Ensure that wall fixings are appropriate to support this weight. The product should be mounted no further than 10 cm from the control and indicating equipment, close coupled by conduit if it is being used to power the CIE directly.
- 7) Fix to wall or other structure in correct orientation i.e. with hinge on left hand side, using screws of sufficient size and length through the mounting holes.
- 8) Protect the battery terminals from any metal surfaces during installation as shorting of the terminals is hazardous.
- 9) Knock-outs are provided in the case for mating with external trunking or conduit.
- 10) Ensure that all unused holes (on the rear of the case) are sealed to prevent the ingress of damp and dust.

Figure 1 – Box Mounting

“E” Enclosure

“C” Enclosure

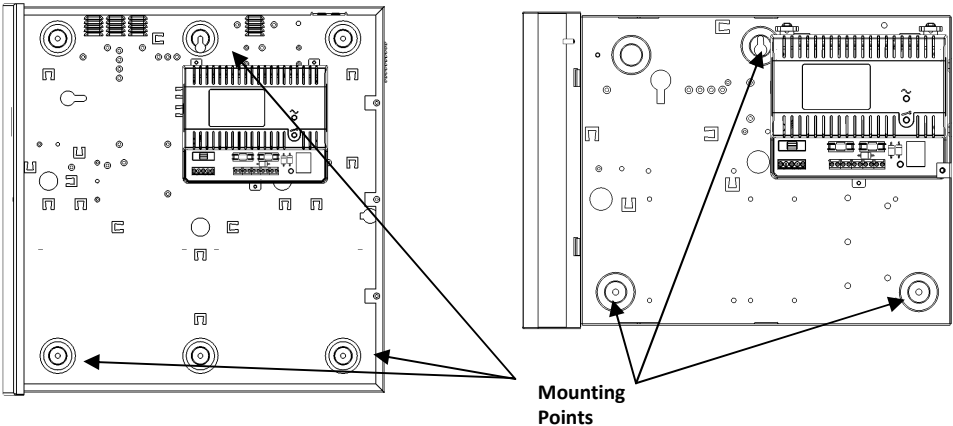
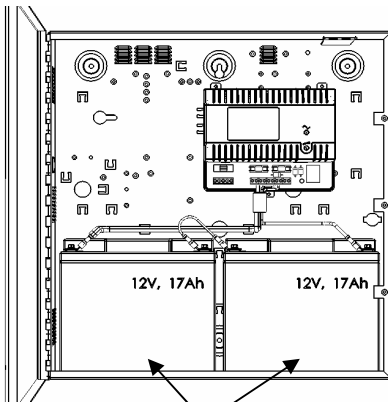
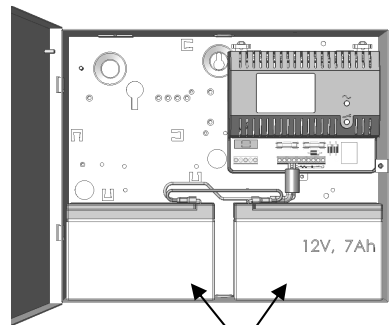

Figure 2 – Battery fitting and assembly



**Fit 2 x 12V
17/18 Ah batteries**



**Fit 2 x 12V
7 Ah batteries**

WARNING: ALWAYS FIT 2 BATTERIES and wire in series, the product will NOT work with a single 12 V battery

COMMISSIONING

Mains Power Up

- 1) With no external connections made to the PSE, connect the mains input wires to the terminal block, **ensuring that the mains isolator (disconnect device) is open**. Fasten wiring in place with cable tie to saddle. **Note: Equipment must be earthed.**
- 2) Apply mains input. Confirm that all LED indicators flash on briefly proving integrity of indicating circuits. Ensure that the green Mains LED then stays illuminated and that the yellow Fault LED flashes after approximately 3 s (indicating a disconnected battery).
- 3) Disconnect the mains power.

Load Output and Remote Signalling

- 4) Connect the EPS and GEN PSE Fault outputs to the appropriate inputs of control equipment if remote fault monitoring is required.
- 5) Loop the load (output) wiring through the supplied ferrite EMC suppressor. Cable tie to saddle provided (adjacent to exit hole).

Figure 3 – Connections

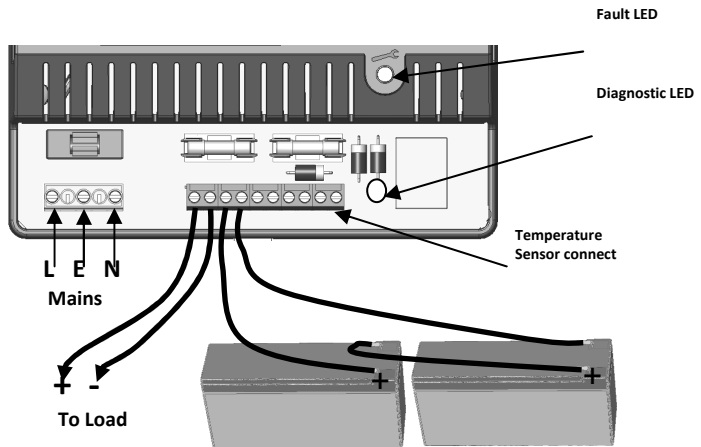

- 6) Re-apply mains. Verify that the green Mains LED illuminates and the yellow Fault LED flashes after approximately 3 s (disconnected battery).
- 7) If connected, verify that the EPS Fault monitor shows a *closed* contact and the GEN PSU Fault monitor shows an *open* contact.
- 8) Perform a full functional test of connected system (load) including full alarm condition.

Figure 4 – Terminal labels

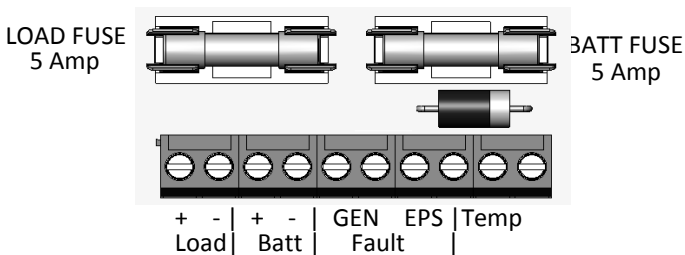

Standby Battery

- 9) Mount the appropriate batteries as shown in figure 2.
- 10) Connect the two 12 V standby batteries in series using the single cable provided. Connect the *negative* of one battery to the *positive* of the other.
DO NOT CONNECT the two remaining (free) battery terminals to each other!
- 11) Connect the free Positive and Negative terminals of the batteries to the PCB terminals Batt+ and Batt - using the cables provided. See Figure 2 and 3. **CAUTION – significant energy can be released from even an uncharged SLA battery – so when connecting the last battery lead, take extreme care to attach this lead only to the correct terminal, and avoid shorting it to any other terminal or conducting surface.**
- 12) Verify that the yellow Fault LED does not flash (battery connection detected). Verify that the remote PSU Fault monitor shows a *closed* contact.
- 13) Disconnect the mains power. Verify that the green Mains LED extinguishes and the Yellow Fault LED starts to pulse (indicating that the PSE is running from its standby batteries).
- 14) If connected, verify that the EPS Fault monitor shows an *open* contact and the GEN PSU Fault monitor shows a *closed* contact.
- 15) Verify that the standby batteries are now driving (supporting) the system load. Perform a full functional test of system including full alarm condition Note: ensure batteries have sufficient charge to support the system under full load.

Final

- 16) Reconnect the mains. Verify that the green Mains LED illuminates and the yellow Fault LED extinguishes.
- 17) If connected, verify that the EPS Fault monitor shows a *closed* contact and the GEN PSU Fault monitor shows a *closed* contact.
- 18) Disconnect one of the battery leads, ensuring that no exposed section of conductor or connector is allowed to contact exposed metal-work, other PSE terminals, or other battery terminals.
- 19) Verify that, in less than 10 s, the yellow Fault LED starts to flash, and that the orange Diagnostic LED flashes in a 2 pulse repeating pattern, (indicating that battery disconnection was detected).
- 20) Reconnect the battery lead and, after approximately 5 s, verify that that the Fault LED does not flash. (Audible click can be heard as the battery relay closes, then a second click while the charger is tested.)
Note: If it is necessary to obtain confirmation of charging current; between steps 18 and 20, an ammeter can be placed in series with the battery leads. Continue to observe caution with all exposed conductors when inserting or removing the meter and when restoring normal battery wiring.
- 21) Close cover and secure using fastening screws provided.

OPERATING INSTRUCTIONS

In the event of loss of mains, a battery fault or a GEN PSU fault, the corresponding Fault signal contacts will open.

If the output of the PSE fails, the cause of the failure should be investigated e.g. short circuit load, connection of a deeply discharged battery. The fault should be rectified before restoring power to the PSE. If any of the fuses require replacing, ensure the correct fuse rating and type is used.

MAINTENANCE

This unit is intended for use by Service Personnel only. There are NO USER SERVICEABLE parts inside.

There is no regular maintenance required of the PSE other than periodic testing, and replacement of the standby battery. **Reference should be made to the battery manufacturer's documentation to determine typical/expected battery life with a view to periodic replacement of the battery.**

COMPLIANCE

This power supply unit meets the essential requirements of the following EU Directives:

CPR:	305/2011 EU
EMC:	2014/30/EU
Low Voltage:	2014/35/EU
WEEE:	2012/19/EU
RoHS:	2011/65/EU

Functional standard: EN54-4:1997 +A1 +A2
Environmental Class II

Certification Body: Underwriters Laboratory

Declaration of Performance: DOP2014/06
DOP2014/07

CE
0843

Elmdene International Ltd 3 Keel Close
Portsmouth PO35QD
14
0843-CPR-0215
EN54-4:1997 +A1 +A2
Power Supplies intended for use in fire detection
and fire alarm systems

Operational reliability	- Pass
Durability	
Temperature resistance	- Pass
Vibration resistance	- Pass
Electrical stability	- Pass
Humidity resistance	- Pass

DISPOSAL OF PRODUCT AT END OF LIFE

This product falls within the scope of EU Directives 2012/19/EU Waste Electrical and Electronic Equipment (WEEE) and 2013/56/EU (Battery). At the end of life, the product must be separated from the domestic waste stream and disposed via an appropriate approved WEEE disposal route in accordance with all national and local regulations.

Before disposal of the product, any batteries must be removed, and disposed separately via an appropriate approved battery disposal route in accordance with all national and local regulations. Package used batteries safely for onward transport to your supplier, collection point or disposal facility.

Caution: Risk of fire or explosion
if bare battery wires are allowed to touch.

See Specification for battery type information. The battery is marked with the crossed out wheelee bin symbol, which may include lettering to indicate cadmium (Cd), lead (Pb), or mercury (Hg).

For more information see: www.recyclethis.info

Explanation of symbols: (Not all may apply)

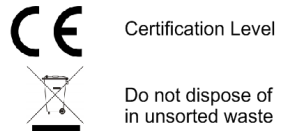
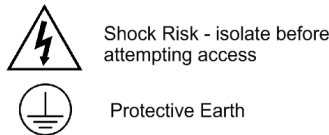

Specifications subject to change without notice

*The packaging supplied with this product may be recycled.
Please dispose of packaging accordingly.*