

SAJ

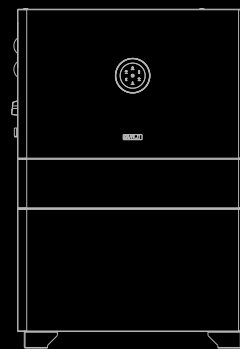
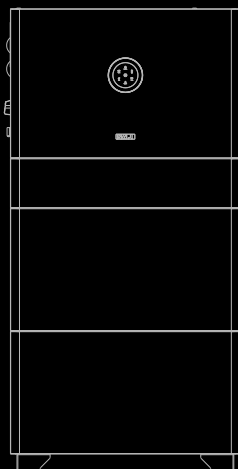
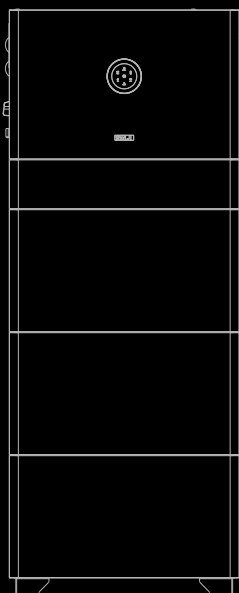

HS3 Series

**SINGLE-PHASE ALL-IN-ONE ENERGY STORAGE SYSTEM
USER MANUAL**

HS3-(3K-6K)-S2-(W, G)-(B, P)X

TABLE OF CONTENTS

1. SAFETY PRECAUTIONS	1
1.1. About This Document	2
1.1.1. Overview	2
1.1.2. Target audience	2
1.2. Safety	2
1.2.1. Safety Levels	2
1.2.2. Symbol Explanation	3
1.2.3. Safety Instructions	4
1.3. Safe Handling	5
1.3.1. Inverter	5
1.3.2. Battery	6
1.4. Emergency	6
2. Product Information	9
2.1. General Introduction	10
2.2. Models	10
2.2.1. Product Models	10
2.2.2. Model Description	11
2.3. Dimension	12
2.3.1. HS3 Inverter	12
2.3.2. BU3 Battery Pack	13
2.3.3. BC3 Battery Junction Box	15
2.3.4. CU2 Charger	15
2.4. Ports, switches, and LED on the HS3 inverter	16

2.5.	LED Indicators on the HS3 Inverter.....	17
2.6.	Datasheet.....	19
2.6.1.	System.....	19
2.6.2.	Battery Pack.....	23
2.6.3.	Battery Junction Box.....	23
2.6.4.	Charger.....	24
3.	Transportation and Storage.....	27
3.1.	Transportation.....	28
3.2.	Storage.....	28
4.	Installation.....	31
4.1.	Precautions.....	32
4.2.	Determining the Installation Site.....	32
4.2.1.	Installation Environment Requirements.....	32
4.2.2.	Installation Location Requirements.....	33
4.3.	Preparing Installation Tools.....	35
4.4.	Unpacking.....	36
4.4.1.	Checking the Outer Packing.....	36
4.4.2.	Checking the Package Contents.....	36
4.5.	Installation.....	40
4.5.1.	Type A battery pack: ground mounting manner.....	40
4.5.2.	Type B battery pack: ground mounting manner.....	50
4.5.3.	Type B Battery Pack: wall mounting manner.....	61
4.5.4.	Installation of Multiple Battery Stacks (Optional).....	72
5.	Electrical Connection.....	77
5.1.	Safety Instructions.....	78
5.2.	Assembling the AC-side Connection.....	78
5.2.1.	Opening the AC-side Cover.....	78
5.2.2.	Connecting the Grounding Cable.....	79
5.2.3.	(Optional) Installing the SIM Card.....	80
5.2.4.	(Optional) Assembling the LAN Electrical Connection.....	81

5.2.5.	Assembling the EMS Electrical Connection	83
5.2.6.	Installing a Circuit Breaker	84
5.2.7.	Installing an RCD (optional)	84
5.2.8.	Connecting the Smart Meter	84
5.2.9.	Connecting the Grid and Backup Loads	84
5.2.10.	Assembling the Communication Connection	86
5.2.11.	Closing the AC-side Cover	92
5.3.	Assembling the DC-side Connection	93
5.3.1.	Opening the DC-side Cover	93
5.3.2.	Connecting the PV Cables	94
5.3.3.	(Optional) Connecting Cables between Multiple Battery Stacks.....	97
5.3.4.	Closing the DC-side Cover.....	100
5.4.	Earth Fault Alarm.....	100
5.5.	System Connection.....	101
5.6.	System Connection Diagram.....	103
6.	Startup and Shutdown	105
6.1.	Startup	106
6.2.	Shutdown	106
7.	Commissioning.....	107
7.1.	About the Elekeeper App.....	108
7.2.	Downloading the App	108
7.3.	Using the App.....	108
8.	Troubleshooting	109
9.	Appendix.....	117
9.1.	Recycling and Disposal	118
9.2.	Warranty	118
9.3.	Contacting Support.....	118
9.4.	Trademark.....	118



1.

**SAFETY
PRECAUTIONS**



1.1. About This Document

1.1.1. Overview

This *User Manual* provides introductions and instructions of installing, operating, maintaining, and troubleshooting of the SAJ system HS3-(3K-6K)-S2-(W,G)-(B,P).X. It is a single-phase all-in-one energy storage system which includes the SAJ products listed in section 2.2 "Models".

Read the user manual carefully before any installation, operation and maintenance and follow the instructions during installation and operation. Keep this manual all time available in case of emergency.

1.1.2. Target audience

This document is applicable to:

- Installers
- Users

1.2. Safety

CAUTION:

ONLY qualified and trained electricians who have read and fully understood all safety regulations contained in this manual can install, maintain, and repair the equipment. Access to the equipment is by the use of a tool, lock and key, or other means of security.

1.2.1. Safety Levels











 DANGER
Indicates a hazardous situation which, if not avoided, will result in death or serious injury.



 WARNING
Indicates a hazardous situation which, if not avoided, can result in death or serious injury or moderate injury.

 CAUTION
Indicates a hazardous condition which, if not avoided, can result in minor or moderate injury.

 NOTICE
Indicates a situation that can result in potential damage, if not avoided.

1.2.2. Symbol Explanation

Symbol	Description
	Danger: Electrical shock hazard This device is directly connected to public grid and thus all work to the battery shall only be carried out by qualified personnel.
	WARNING: No open flames Do not place or install near flammable or explosive materials.
	Danger: Hot surface The components inside the battery will release a lot of heat during operation. Do not touch metal plate housing during operating.
	Attention: Install the product out of reach of children.
	Attention: Check the user manual before service. If an error has occurred, refer to the troubleshooting chapter to remedy the error.
	Attention: This device shall NOT be disposed of in residential waste.
	Attention: This battery module shall NOT be disposed of in residential waste.
	CAUTION: Risk of electric shock from energy stored in capacitor. Do not remove cover until 5 minutes after disconnecting all sources of supply
	CE Mark Equipment with the CE mark fulfills the requirements of the Low Voltage Directive and Electro Magnetic Compatibility.
	RoHS compliant mark Equipment with the RoHS mark does not exceed the allowable amounts of the restricted substances defined in Restriction of Hazardous Substances in Electrical and Electronic Equipment.

	<p>RCM compliant mark Equipment with the RCM mark is in compliance with AS/NZS 4417.1 & 2 and the EESS.</p>
	<p>Recyclable</p>

1.2.3. Safety Instructions

For safety, be sure to read all the safety instructions carefully prior to any works, and please observe the appropriate rules and regulations of the country or region where you installed all-in-one energy storage system.

 DANGER
<ul style="list-style-type: none"> • There is possibility of fatal personnel injuries due to electrical shock and high voltage. • Do not touch the surface of the equipment while the housing is wet, otherwise, it might cause electrical shock. • Do not touch the operating component of the device; it might result in burning or death. • To prevent risk of electric shock during installation and maintenance, please make sure that all AC and DC terminals are plugged out. • Do not stay close to the equipment while there are severe weather conditions including storm, lightning, etc. • Before opening the housing, the SAJ inverter must be disconnected from the grid and PV generator; you must wait for at least five minutes to let the energy storage capacitors completely discharged after disconnecting from power source. • Please keep the power off prior to any operations. • Do not use the battery or the battery control unit if it is defective, broken or damaged. • Do not subject the battery to any strong force. • Do not place the battery near a heat source, such as direct sunlight, a fireplace. • Do not expose the battery to temperatures in excess of 50°C. • Keep inflammable and explosive dangerous items or flames away from the battery. • Do not soak the battery in water or expose it to moisture or liquids. • Do not use the battery in vehicles. • Do not use the battery in areas where the ammonia content of the air exceeds 20 ppm.

 **WARNING**

- Any unauthorized actions including modification of product functionality of any form may cause lethal hazard to the operator, third parties, the units or their property. SAJ is not responsible for the loss and these warranty claims.
- Do not touch non-insulated parts or cables.
- For personal and property safety, do not short-circuit the positive (+) and negative (-) electrode terminals.
- Disconnect the PV array from the inverter by using an external disconnection device. If no external disconnection device is available, wait until no more DC power is applied to the inverter.
- Disconnect the AC circuit breaker, or keep it disconnected if it is tripped, and secure it against reconnection.
- The SAJ inverter must only be operated with the PV generator. Do not connect any other source of energy to the SAJ inverter.
- Be sure that the PV generator and inverter are well grounded in order to protect properties and persons.

 **CAUTION**

- Only qualified personnel who has full knowledge of local safety regulations and local standards on battery can install, maintain, retrieve, and process this product.
- Only use the battery as intended and designed. Do not change any components in the battery.
- Risk of damage due to improper modification
- Use professional tools when operating the products.
- The inverter will become hot during operations. Do not touch the heat sink or peripheral surface during or shortly after operation.

 **NOTICE**

- During installation of the battery, the circuit breaker must be disconnected from the battery pack wiring.

1.3. Safe Handling

1.3.1. Inverter

- Only qualified electricians who have read and fully understood all safety regulations in this manual can install, maintain, and repair the inverter.
- When the inverter is working, do not touch the internal components or cables to avoid electric shock.

- When the inverter is working, do not plug in or out the cables.
- Make sure that the AC input voltage and current are compatible with the rated voltage and current of the inverter; otherwise, components might be damaged, or the device cannot work properly.

1.3.2. Battery

- Operate and use the battery properly according to the user manual. Any attempts to modify battery without the permission from SAJ will void the limit warranty for the battery.
- The battery must be installed at a suitable location with sufficient ventilation.
- Do not use the battery if it is defective, damaged, or broken.
- Only use the battery with a compatible inverter.
- Use batteries of the same type in an ESS. Do not mix the battery with other types of battery.
- Make sure that the battery is grounded prior to use.
- Do NOT pull out any cables or open the battery enclosure when the battery is powered on.
- Only use the battery as intended and designed. Do not change any components in the battery.
- It is recommended not to mix old and new battery modules, because doing so will not only cause capacity mismatch, but also affect battery performance and service life.
- It is recommended not to mix batteries with different SOC states, and better to use batteries from the same production batch together, because this can reduce the risk of abnormalities.
- If the user wants to expand the capacity later, it is recommended to add a cluster of batteries with the same configuration and use them in parallel with the original batteries.

1.4. Emergency

Despite of its careful and professional protection design against any hazards, damage of the battery may still possible. If a small amount of battery electrolyte is released due to a serious damage of the outer casing; or if the battery explodes due to not being treated timely after a fire breaks out nearby, and leaks out poisonous gases such as carbon monoxide, carbon dioxide and etc., the following actions are recommended:

- Eye contact: Rinse eyes with a large amount of running water and seek medical advice.
- Contact with skin: Wash the contacted area with soap thoroughly and seek medical advice.
- Inhalation: If you feel discomfort, dizziness, or vomiting, seek medical advice immediately.
- Use a FM-200 or Carbon Dioxide (CO₂) fire extinguishers to extinguish the fire if there is a fire in the

area where the battery pack is installed. Wear a gas mask and avoid inhaling toxic gases and harmful substances produced by the fire.

- Use an ABC fire extinguisher, if the fire is not caused by battery and not spread to it yet.

 **WARNING**

- If a fire has just occurred, try to disconnect the battery circuit breaker, and cut off the power supply first, but only if you can do so without endangering yourself.
- If the battery is on fire, do not attempt to extinguish the fire but evacuate the crowd immediately.

Potential danger of damaged battery:

- **Chemical Hazard:**

Despite of its careful and professional protection design against any hazard results, rupture of battery may still occur due to mechanical damage, internal pressure etc., and may result in a leakage of battery electrolyte. The electrolyte is corrosive and flammable. When there is fire, the toxic gases produced will cause skin and eyes irritation, and discomfort after inhalation. Therefore:

- Do not open damaged batteries.
- Do not damage the battery again (shock, fall, trample, etc.).
- Keep damaged batteries away from water (except to prevent an energy storage system from catching fire).
- Do not expose the damaged battery to the sun to prevent internal heating of the battery.

- **Electrical hazard:**

The reason of fire and explosion accidents in lithium batteries is battery explosion. Here are the main factors of battery explosion:

- Short-circuit of battery. Short circuit will generate high heat inside battery, resulting in partial electrolyte gasification, which will stretch the battery shell. The temperature reaching ignition point of internal material will lead to explosive combustion.
- Overcharge of battery. Overcharge of battery may precipitate lithium metal. If the shell is broken, it will come into direct contact with the air, resulting in combustion. The electrolyte will be ignited at the same time, resulting in strong flame, rapid expansion of gas and explosion.

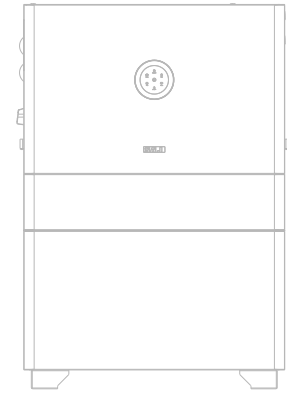
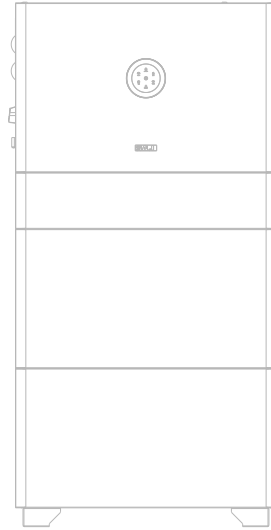

2.

**PRODUCT
INFORMATION**



2.1. General Introduction

The SAJ system HS3-(3K-6K)-S2-(W, G)-(B, P)*X* contains at least one HS3 inverter and one BU3 battery pack. It is a single-phase all-in-one energy storage system which is applied to the residential photovoltaic energy storage system which stores the electricity for household future use.

The HS3 inverter is built internally with a battery management system (BMS), which is used to ensure efficiency of the battery and protect the battery from operating outside its specified limitations. Working with an optional BC3 battery junction box, up to 8 battery packs can be used for storage expansion. Working with an optional CU2 charger, it provides power to the EV charger.

Note: *X* is the quantity of the battery modules, ranging from 1 to 8.

2.2. Models

2.2.1. Product Models

The following tables list the device models of the HS3-(3K-6K)-S2-(W, G)-(B, P)*X* system with an optional battery junction box or a charger.

■ Inverter

Model type Communication	Basic model	Professional model
With a built-in AIO3 module	<ul style="list-style-type: none"> ● HS3-3K-S2-W-B ● HS3-3.6K-S2-W-B ● HS3-4K-S2-W-B ● HS3-4.6K-S2-W-B ● HS3-5K-S2-W-B ● HS3-5K-S2-W-B-BE* ● HS3-6K-S2-W-B ● HS3-6K-S2-W-B-IE* 	<ul style="list-style-type: none"> ● HS3-3K-S2-W-P ● HS3-3.6K-S2-W-P ● HS3-4K-S2-W-P ● HS3-4.6K-S2-W-P ● HS3-5K-S2-W-P ● HS3-5K-S2-W-P-BE* ● HS3-6K-S2-W-P ● HS3-6K-S2-W-P-IE*
With a built-in 4G module	<ul style="list-style-type: none"> ● HS3-3K-S2-G-B ● HS3-3.6K-S2-G-B ● HS3-4K-S2-G-B ● HS3-4.6K-S2-G-B ● HS3-5K-S2-G-B ● HS3-5K-S2-G-B-BE* 	<ul style="list-style-type: none"> ● HS3-3K-S2-G-P ● HS3-3.6K-S2-G-P ● HS3-4K-S2-G-P ● HS3-4.6K-S2-G-P ● HS3-5K-S2-G-P ● HS3-5K-S2-G-P-BE*

	<ul style="list-style-type: none"> ● HS3-6K-S2-G-B ● HS3-6K-S2-G-B-IE* 	<ul style="list-style-type: none"> ● HS3-6K-S2-G-P ● HS3-6K-S2-G-P-IE*
--	--	--

* BE indicates that this model is available in Belgium only.

* IE indicates that this model is available in Ireland only.

■ Battery

Equipment	Basic model	Professional model
Battery	<ul style="list-style-type: none"> ● BU3-5.0-TV1 ● BU3-5.0-TV2 	<ul style="list-style-type: none"> ● BU3-5.0-TV1-PRO ● BU3-5.0-TV2-PRO
Battery with a base	<ul style="list-style-type: none"> ● BU3-5.0-TV1-BASE ● BU3-5.0-TV2-BASE 	<ul style="list-style-type: none"> ● BU3-5.0-TV1-PRO-BASE ● BU3-5.0-TV2-PRO-BASE

■ Battery junction box

BC3-TV

■ Charger

CU2-7.4K-S-I

2.2.2. Model Description

HS3 - xK - S2 - W - B X - IE
HS3 - xK - S2 - G - P X - BE

HS3: Inverter model series

xK: Rated power. For example, 6K indicates the rated power of the inverter is 6 kW.

S2: Single phase with 2 MPPT

W: This model uses a built-in AIO3 module.

G: This model uses a built-in 4G module.

B: Basic model

P: Professional model

X: Quantity of the battery modules, ranging from 1 to 8.

IE: This model is applicable to Ireland ONLY.

BE: This model is applicable to Belgium ONLY.

BU3 - 5.0 - TVx - PRO - BASE

BU3: Battery model series

5.0: The rated energy of the battery is 5.0 kWh.

TVx: TV indicates a pack-level optimizer. x indicates the battery cell manufacturer.

PRO: Professional model

BASE: With a base

2.3. Dimension

2.3.1. HS3 Inverter

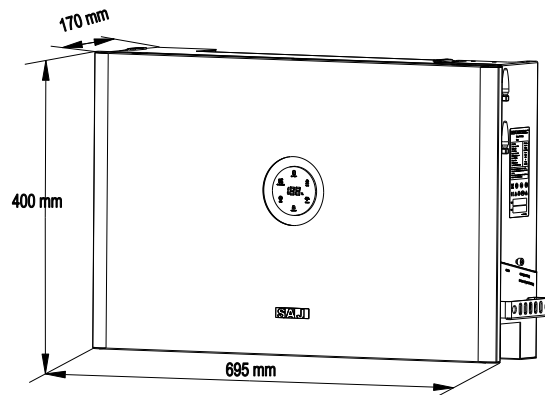

Figure 2.1. Dimension of the HS3 inverter

2.3.2. BU3 Battery Pack

■ Type A battery pack

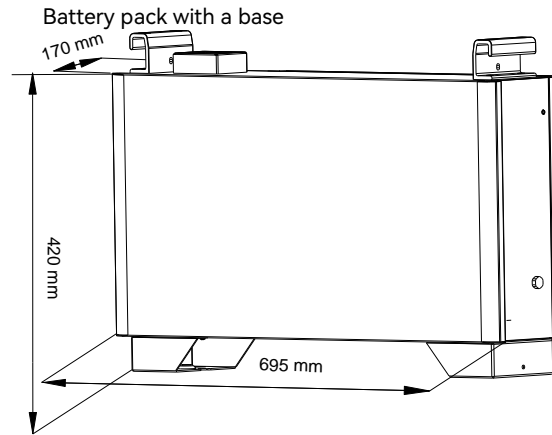

Figure 2.2. Dimension of the type A BU3 battery pack with a base

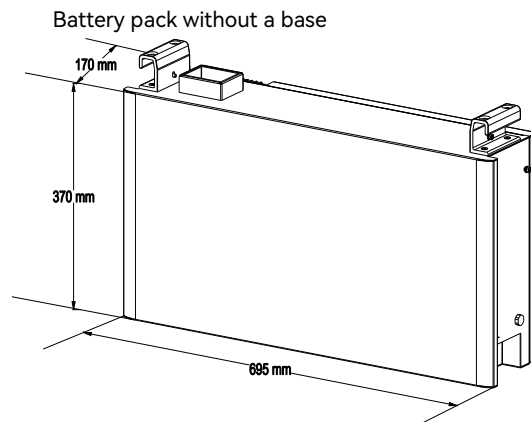

Figure 2.3. Dimension of the type A BU3 battery pack without a base

■ Type B battery pack

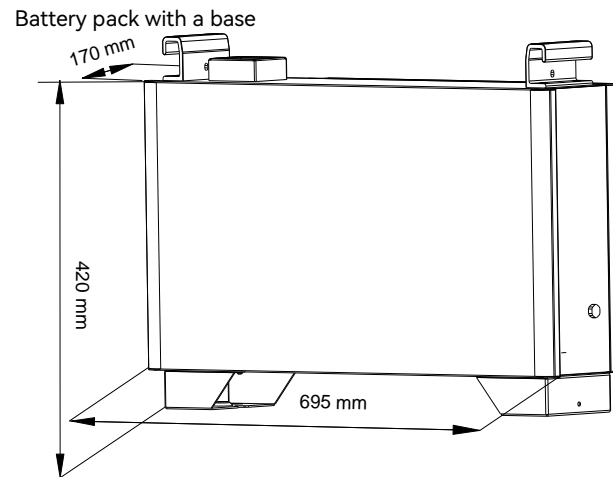
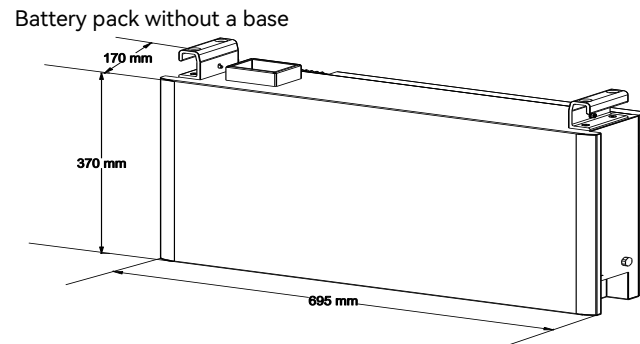

Figure 2.4. Dimension of the type B BU3 battery pack with a base



Dimension of the type B BU3 battery pack without a base

2.3.3. BC3 Battery Junction Box

Dimension (mm): 150*695*170

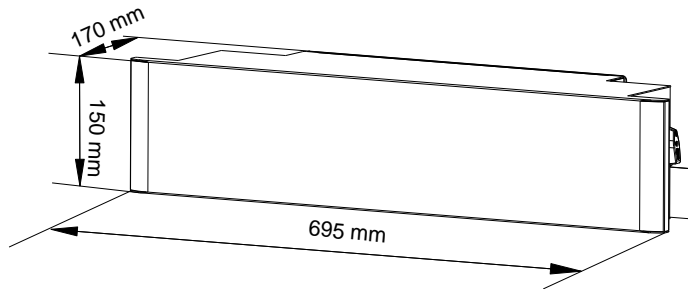

Figure 2.5. Dimension of the BC3 battery junction box

2.3.4. CU2 Charger

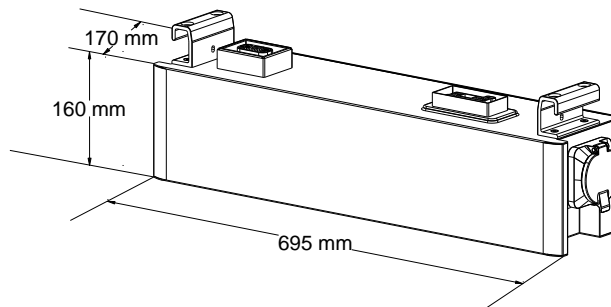

Figure 2.6. Dimension of the CU2 charger

2.4. Ports, switches, and LED on the HS3 inverter

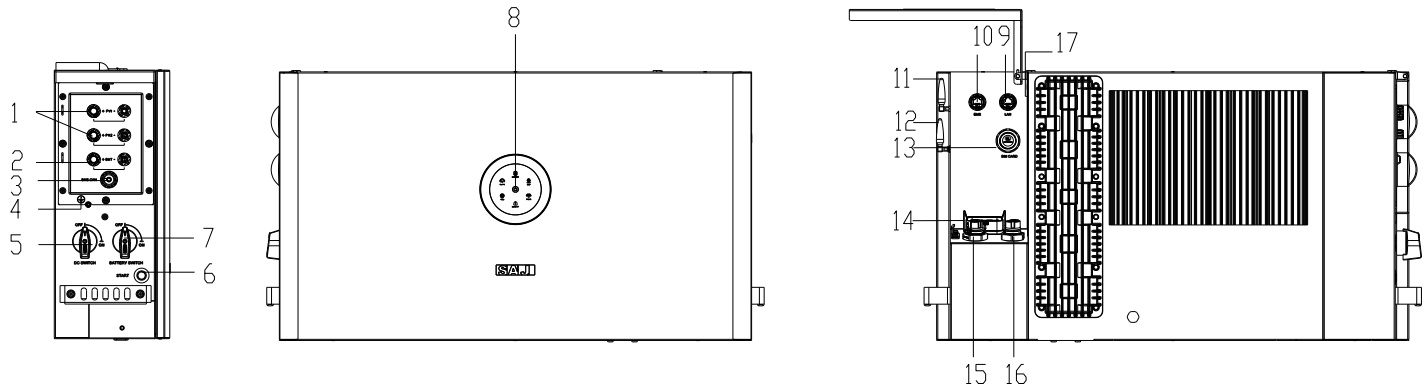

Figure 2.7. Ports, switches, and LED on the HS3 inverter

Callout	Silkscreen	Description
1	PV1 (+, -), PV2 (+, -)	PV input ports
2	BAT (+, -)	BAT+ and BAT- ports Used for paralleling connection.
3	BMS CAN	Battery communication port
4	/	Grounding port
5	DC SWITCH	Switch for controlling the PV input
6	START	Start button
7	BATTERY SWITCH	Switch for controlling battery power input and output
8	/	LED panel
9	LAN	LAN port Only available when an AIO3 module is embedded in the inverter. It is used by the AIO3 module for communication.
10	EMS	EMS port Used in the paralleling scenario.
11	WIFI	Wi-Fi/Bluetooth antenna
12	4G	4G antenna Only available when a 4G module is embedded in the inverter.
13	SIM CARD	SIM card slot. Only available when a 4G module is embedded in the inverter.

14	COMM	Communication port
15	BACK-UP	Backup load port
16	GRID	Grid port
17	/	Grounding port

Table 2.1. Description of the HS3 ports, switches, and LED

2.5. LED Indicators on the HS3 Inverter

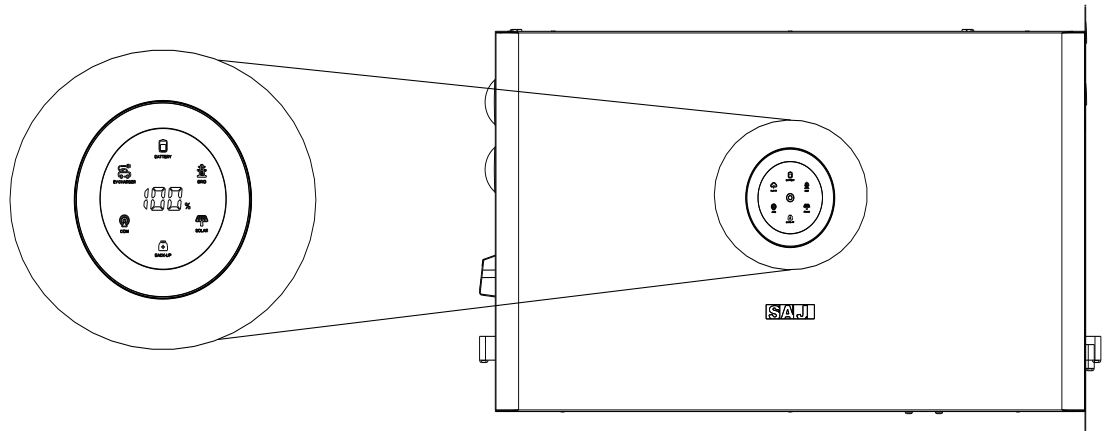

Figure 2.8. HS3 inverter LED

LED indicator	Status	Description
	Off	The inverter is powered off.
	Breathing 6s	The inverter is in initialization or standby state.
	Solid on	The inverter is working properly.
	Breathing 3s	The inverter is upgrading.
	Solid on	The inverter is not working properly.
 System	<i>Integer</i> (example, 50)	Battery average SOC (for example, 50%)
	--	The battery communication is lost.







 Battery	Solid on	The battery is discharging.
	On 1s, off 3s	The battery is charging.
	On 1s, off 1s	The battery is not working properly.
	Off	The battery is disconnected or inactive.
 Grid	Solid on	The grid is connected and working properly.
	On 1s, off 1s	The grid is not working properly.
	Off	No grid is detected.
 PV	Solid on	The PV array is working properly.
	On 1s, off 1s	The PV array is not working properly.
	Off	The PV array is not working.
 Backup	Solid on	The AC-side load is working properly.
	On 1s, off 1s	The AC-side load is overloaded.
	Off	The AC-side load is disconnected or off.
 Communication	Solid on	In good communication with the meter, BMS, and cloud.
	On 1s, off 1s	Lost communication with the meter, BMS, or cloud.
	Off	Lost communication with all the meter, the BMS, and cloud.
 EV charger	Solid on	The EV charger is in standby mode and working properly.
	On 1s, off 1s	The EV charger is charging.
	On 1s, off 3s	The EV charger is not working properly.
	Off	The EV charger is disconnected.

Table 2.2. LED description

2.6. Datasheet

2.6.1. System

Notes:

W=Wi-Fi

G=4G

B=Basic model

P=Professional model

IE=Ireland (This model is applicable to Ireland ONLY.)

BE=Belgium (This model is applicable to Belgium ONLY.)

Model	HS3-3K-S2-(W, G)-(B, P)X	HS3-3.6K-S2-(W, G)-(B, P)X	HS3-4K-S2-(W, G)-(B, P)X	HS3-4.6K-S2-(W, G)-(B, P)X	HS3-5K-S2-(W, G)-(B, P)X, HS3-5K-S2-(W, G)-(B, P)X-BE	HS3-6K-S2-(W, G)-(B, P)X, HS3-6K-S2-(W, G)-(B, P)X-IE
DC Input						
Max. PV Array Power [Wp]@STC	<ul style="list-style-type: none"> ● Basic: 4500 ● Professional: 6000 	<ul style="list-style-type: none"> ● Basic: 5400 ● Professional: 7200 	<ul style="list-style-type: none"> ● Basic: 6000 ● Professional: 8000 	<ul style="list-style-type: none"> ● Basic: 6900 ● Professional: 9200 	<ul style="list-style-type: none"> ● Basic: 7500 ● Professional: 10000 	<ul style="list-style-type: none"> ● Basic: 9000 ● Professional: 12000
Max. Input Voltage [V]	600					
Start Voltage / Min. Input Voltage[V]	100					
Rated Input Voltage [V]	360					
MPPT Voltage Range [V]	90–550					
Max. Input Current [A]	<ul style="list-style-type: none"> ● Basic: 16/16 ● Professional: 20/20 					
Max. Short Circuit Current [A]	<ul style="list-style-type: none"> ● Basic: 20/20 ● Professional: 25/25 					
MPPT Quantity	2					
Battery Port Connection						
Battery Type	LiFePO4					
Battery Voltage Range [V]	380–500					
Max. Charging Current [A]	15.8					
Max. Discharging Current [A]	9.2	10	12.4	12.9	<ul style="list-style-type: none"> ● 15.2 ● 13.9 (BE model) 	<ul style="list-style-type: none"> ● 16.8 ● 16 (IE model)

Parameter \ Model	HS3-3K-S2-(W, G)-(B, P)X	HS3-3.6K-S2-(W, G)-(B, P)X	HS3-4K-S2-(W, G)-(B, P)X	HS3-4.6K-S2-(W, G)-(B, P)X	HS3-5K-S2-(W, G)-(B, P)X, HS3-5K-S2-(W, G)-(B, P)X-BE	HS3-6K-S2-(W, G)-(B, P)X, HS3-6K-S2-(W, G)-(B, P)X-IE
Scalability	Quantity of battery packs connecting to one inverter: 1 to 8 Note: A maximum of 3 battery packs can be installed in one stack.					
AC Output [On-grid]						
Rated AC Power [W]	3000	3600	4000	4600	5000	<ul style="list-style-type: none"> ● 6000 ● 5750 (IE model)
Max. Apparent Power [VA]	3300	3600	4400	4600	<ul style="list-style-type: none"> ● 5500 ● 5000 (BE model) 	<ul style="list-style-type: none"> ● 6000 ● 5750 (IE model)
Rated Output Current [A] @230 V AC	13.0	15.7	17.4	20.0	21.7	<ul style="list-style-type: none"> ● 26.1 ● 25 (IE model)
Max. Continuous Current [A]	14.3	15.7	19.1	20.0	<ul style="list-style-type: none"> ● 23.9 ● 21.7 (BE model) 	<ul style="list-style-type: none"> ● 26.1 ● 25 (IE model)
Current Inrush [A]	75					
Max. AC Fault Current [A]	95					
Max. AC Over-Current Protection [A]	26.7	32.2	35.7	41	44.5	<ul style="list-style-type: none"> ● 53.5 ● 51.3 (IE model)
Connection Manner	L+N+PE					
Rated AC Voltage / Range [V AC]	220, 230, 240 180-280					
Rated Output Frequency and Range [Hz]	<ul style="list-style-type: none"> ● 50 Hz: 45-55 ● 60 Hz: 55-65 					
Power Factor [cos ϕ]	0.8 leading to 0.8 lagging					
Total Harmonic Distortion [THDi]	<3%					
AC Input [On-grid]						
Connection Manner	L+N+PE					
Rated AC Voltage / Range [V AC]	230					
Rated Input Frequency [Hz]	50, 60					
Max. Input Current [A]	54.5					
Max. Input Current (Inrush) [A]	75					
Max. Inverter Backfeed	0					

Model Parameter	HS3-3K-S2-(W, G)-(B, P)X	HS3-3.6K-S2-(W, G)-(B, P)X	HS3-4K-S2-(W, G)-(B, P)X	HS3-4.6K-S2-(W, G)-(B, P)X	HS3-5K-S2-(W, G)-(B, P)X, HS3-5K-S2-(W, G)-(B, P)X-BE	HS3-6K-S2-(W, G)-(B, P)X, HS3-6K-S2-(W, G)-(B, P)X-IE
Current to the Array [A]						
AC Output [Back-up]						
Max. Apparent Power [VA]	3300	3600	4400	4600	<ul style="list-style-type: none"> ● 5500 ● 5000 (BE model) 	<ul style="list-style-type: none"> ● 6000 ● 5750 (IE model)
Max. Continuous Current [A]	14.3	15.7	19.1	20	<ul style="list-style-type: none"> ● 23.9 ● 21.7 (BE model) 	<ul style="list-style-type: none"> ● 26.1 ● 25 (IE model)
Peak Output Apparent Power [VA]	3600, 60s	4320, 60s	4800, 60s	5520, 60s	6000, 60s	7200, 60s
Connection Manner	L+N+PE					
Rated AC Voltage / Range [V AC]	220, 230, 240 180-280					
Rated Output Frequency/Range [Hz]	<ul style="list-style-type: none"> ● 50 Hz: 45-55 ● 60 Hz: 55-65 					
Output THDv (@ Linear Load)	<3%					
Efficiency						
Max. Efficiency	97.6%					
Euro Efficiency	97.2%					
Protection						
Overload Protection	Integrated					
AC Short Circuit Current Protection	Integrated					
DC Surge Protection	Integrated					
AC Surge Protection	Integrated					
Anti-islanding Protection	Integrated (AFD)					
AFCI Protection	Integrated					
RSD Protection	Optional, compatible with an external protection equipment					
Connection and Communication						
PV Connection	D4; MC4 (optional)					
AC Connection	Plug-in connector					
Battery Connection	Quick connector					
Display	LED + App					
Communication	<ul style="list-style-type: none"> ● Bluetooth (Bluetooth low energy, BLE) 					

Parameter \ Model	HS3-3K-S2-(W, G)-(B, P)X	HS3-3.6K-S2-(W, G)-(B, P)X	HS3-4K-S2-(W, G)-(B, P)X	HS3-4.6K-S2-(W, G)-(B, P)X	HS3-5K-S2-(W, G)-(B, P)X, HS3-5K-S2-(W, G)-(B, P)X-BE	HS3-6K-S2-(W, G)-(B, P)X, HS3-6K-S2-(W, G)-(B, P)X-IE
	<ul style="list-style-type: none"> ● Wi-Fi and Ethernet (W models using the AIO3 module) ● 4G (4G models using the 4G module) 					
Communication Port	<ul style="list-style-type: none"> ● LAN ● CAN ● RS485 ● Dry contact 					
General Parameters						
Topology	Transformer-less					
Operating Temperature Range	<ul style="list-style-type: none"> ● Basic: Charging: 0°C to 50°C Discharging: -10°C to +50°C ● Professional: -30°C to 50°C >45 °C derating 					
Storage Temperature Range	-10°C to 40°C					
Cooling Method	Natural convection					
Ambient Humidity	5–95% non-condensing					
Maximum Operating Altitude	3000 m					
Noise [dBA]	<35					
Overvoltage	II (DC), III (AC)					
Protective Class	I					
Ingress Protection	IP65					
Dimensions [H*W*D] [mm]	400*695*170					
Weight [kg]	26.2					
Warranty [Year]	Refer to the warranty policy.					

2.6.2. Battery Pack

Parameter	Model	BU3-5.0-(TV1, TV2), BU3-5.0-(TV1, TV2)-BASE	BU3-5.0-(TV1, TV2)-PRO, BU3-5.0-(TV1, TV2)-PRO-BASE
	Rated Capacity [Ah]		100
Rated Energy [kWh]		5.0	
Usable Energy [kWh]		4.5	
Dimension (H*W*D) [mm]		<ul style="list-style-type: none"> With the base: 420*695*170 Without the base: 370*695*170 	
Weight [kg]		<ul style="list-style-type: none"> With the base: 53 Without the base: 52 	
Nominal Voltage [V]		450	
Operating Voltage [V]		380-500	
Max. Charging Current [A]		7.9	
Max. Discharging Current [A]		7.9	
Battery Designation		IFpP170/695/370/(1P16S)M/-10+50/90	
Ingress Protection		IP65	
Mounting		<ul style="list-style-type: none"> Ground-mounting Wall-mounting 	
Operating Temperature Range		<ul style="list-style-type: none"> Charging: 0°C to 50°C Discharging: -10°C to +50°C 	-30°C to 50°C
Storage Temperature Range		-10°C to 40°C	
Ambient Humidity		5-95% non-condensing	
Max. Operating Altitude		3000 m	
Cooling Method		Natural convection	
Communication		CAN	
Warranty [Year]		Refer to the warranty policy.	

2.6.3. Battery Junction Box

Parameter	Model	BC3-TV
	Communication Port	
Dimension [mm] (H*W*D)		150*695*170
Weight [kg]		5.3

2.6.4. Charger

Parameter	Model	CU2-7.4K-S-I
Input		
Power supply		1P+N+PE
Rated Voltage [V AC]		230, ± 20%
Rated Current [A]		32
Frequency [Hz]		50/60
Output		
Output Voltage [V AC]		230, ± 20%
Max. Current [A]		32
Rated Output Power [kW]		7
Power Consumption (standby) [W]		7
Efficiency		
Euro Efficiency		≥99%
Power Metering		
Precision		2%
User Interface		
Charging Outlet		Type 2
Housing Material		<ul style="list-style-type: none"> ● Chassis: SGCC (T=1.2 mm) ● Cover: SGCC (T=2 mm)
Startup Mode		Plug and Play (PnP) + App
Communication		
Communication		Wi-Fi 2.4G only
Max. RF Output Power		<20 dBm (-10 dBW)
Safety		
Ingress Protection		IP54
Electrical Protection		<ul style="list-style-type: none"> ● Over-current protection ● Residual current protection ● Surge protection ● Over-current and under-voltage protection ● Over-frequency and under-frequency protection ● Over-temperature protection
Certification		<ul style="list-style-type: none"> ● EN IEC 61851-1: 2019 ● IEC 62955: 2018

	<ul style="list-style-type: none"> ● EN IEC 61851-21-2: 2021 ● EN 61000-6-1: 2019 ● EN 61000-6-3: 2021 ● EN 300 328 V2.2.2:2019 ● EN 301 489-1 V2.2.3:2019 ● EN 301 489-3 V2.1.1:2019 ● EN 301 489-17 V3.2.0:2017
Warranty	Refer to the warranty policy.
Environment	
Working Temperature	-30°C to +50°C
Storage Temperature	-40°C to +60°C
Ambient Humidity	5-95% non-condensing
Max. Operating Altitude [m]	2000
Cooling Method	Natural convection
Package	
Dimension [mm] (H*W*D)	160*695*170
Weight [kg]	9

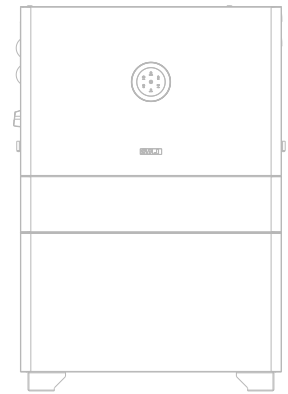
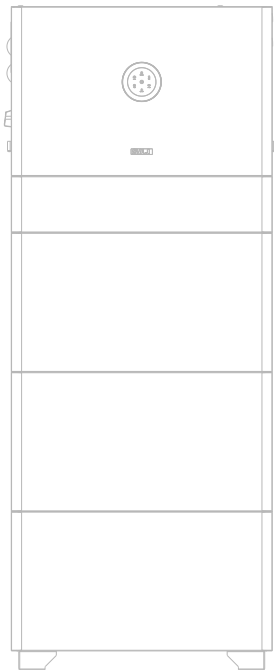

3.

TRANSPORTATION AND STORAGE



3.1. Transportation



Load or unload batteries with caution. Otherwise, the batteries may be short-circuited or damaged (such as leakage and crack), catch fire, or explode.

- Batteries have passed the test of UN38.3. This product meets the transportation requirements for dangerous goods for lithium batteries.
- The transportation service provider must be qualified to transport dangerous goods.
- Before transportation, check that the battery package is intact and that there is no abnormal odor, leakage, smoke, or sign of burning. Otherwise, the batteries must not be transported.
- Keep less than 4 cartons of inverter in one stack and keep less than 4 cartons of battery in one stack.
- After the installation of the battery on site, the original packaging (contains the lithium battery identification) should be kept. When the battery needs to be returned to the factory for repair, use the original packing for battery transportation.

3.2. Storage

- Store it in a dry and ventilated environment and keep it away from heat sources.

Inverter-specific:

- Keep the inverter in an environment with storage temperature as -40°C to $+60^{\circ}\text{C}$, humidity 5% to 95% RH.

Battery-specific:

- Keep the battery in an environment with storage temperature as -10°C to $+40^{\circ}\text{C}$, humidity 5% to 95% RH.
- For long-term storage (>3 months), put the battery in an environment with a temperature of -25°C to 25°C and a humidity of < 85% RH.
- The battery should be installed within 6 months since delivered from the factory and used with compatible inverters.



- The battery remains 50% power when it is sent from the factory.
- The longer the battery is stored, the lower the SOC. When the battery remaining voltage fails to reach the startup voltage requirement, the battery may be damaged.

- Close the battery breaker switch and press the main switch. If the LED light is in solid green, it is running normally. If the LED light is in solid red or off, the battery is not working properly.
- The battery cannot be disposed of as household refuse. When the service life of the battery reaches to the limit, it is not required to return it to the dealer or SAJ, but it must be recycled to the special waste lithium battery recycling station in the area.

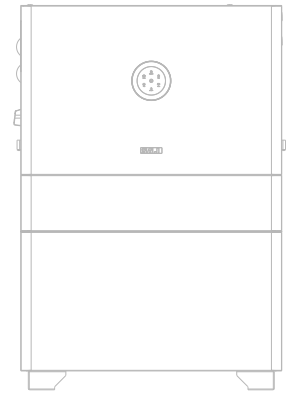
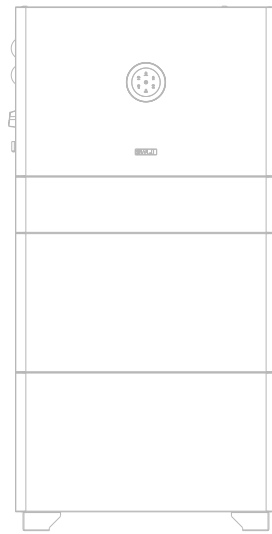



4.

INSTALLATION



4.1. Precautions

For safety, be sure to read all the safety instructions carefully prior to any works and observe the appropriate rules and regulations of the country or region where you installed the energy storage system.

 DANGER
<ul style="list-style-type: none"> • Dangerous to life due to potential fire or electricity shock. • Do not install the inverter near any inflammable or explosive items.
 NOTICE
<ul style="list-style-type: none"> • This equipment meets the pollution degree. • Inappropriate or the harmonized installation environment may jeopardize the life span of the inverter. • Installation directly exposed under intensive sunlight is not recommended. • The installation site must be well ventilated.

4.2. Determining the Installation Site

Read the following sections to cautiously determine the installation site.

The safety regulations vary in different countries and regions. Follow local safety regulations.

4.2.1. Installation Environment Requirements

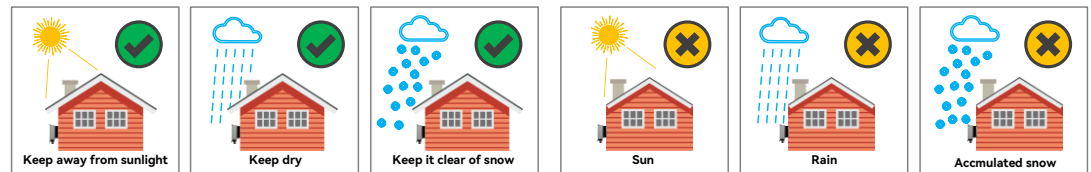

Figure 4.1. Installation location

- Do not expose the device to direct solar irradiation as this could cause power derating due to overheating.
- The installation environment must be free of inflammable or explosive materials.
- The device must be installed in a place away from any heat source.
- Do not install the device at a place where the temperature changes extremely.
- Keep the device away from children.
- Do not install the device at daily working or living areas, including but not limited to the following areas: bedroom, lounge, living room, study, toilet, bathroom, theater, and attic.
- When installing the device at the garage, keep it away from the driveway.

- Keep the device from water sources such as taps, sewer pipes and sprinklers to prevent water seepage.
- The product is to be installed in a high traffic area where the fault is likely to be seen.

4.2.2. Installation Location Requirements

- The device employs natural convection cooling, and it can be installed indoor or outdoor.
 - Indoor requirement: The battery CANNOT be installed in the habitable rooms.
 - Outdoor requirement: The height of the device from the ground should be considered to prevent the device from soaking in water. The specific height is determined by the site environment.
- Install the device vertically. Do not install it forward-tilted, horizontally or upside down.

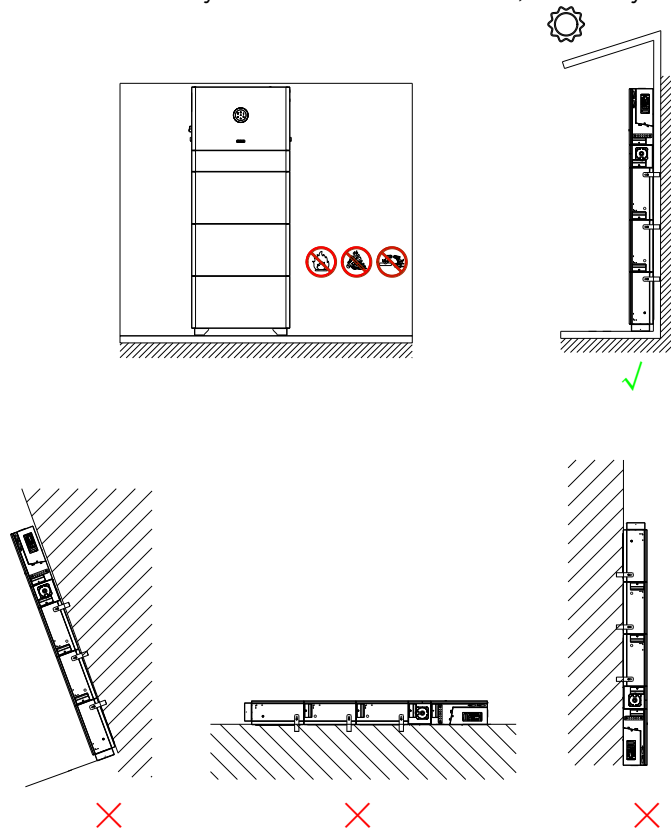

Figure 4.2. Installation limitations

In some restricted conditions, the allowable backward-tilted angle must not be greater than 3 degrees, and the allowable side-tilted angle must not be greater than 2 degrees.

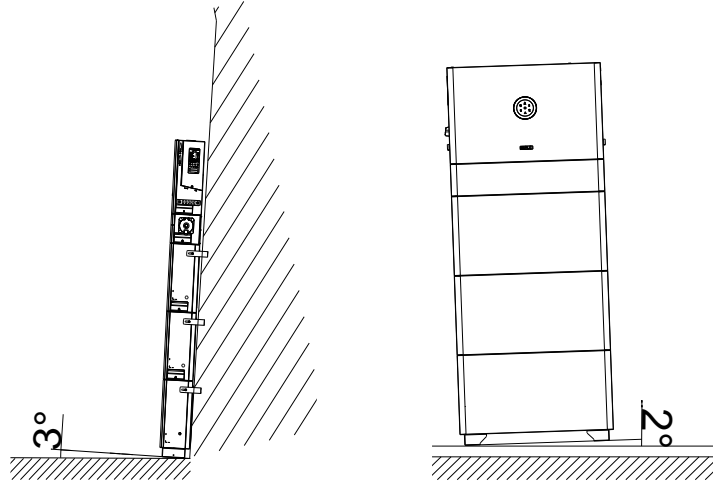

Figure 4.3. Installation angle

- Choose a solid and smooth wall to ensure that the inverter can be installed securely on the wall. Make sure that the wall can bear the weight of the inverter and accessories.
- Reserve enough clearance around the inverter to ensure a good air circulation at the installation area, especially when multiple inverters need to be installed in the same area.

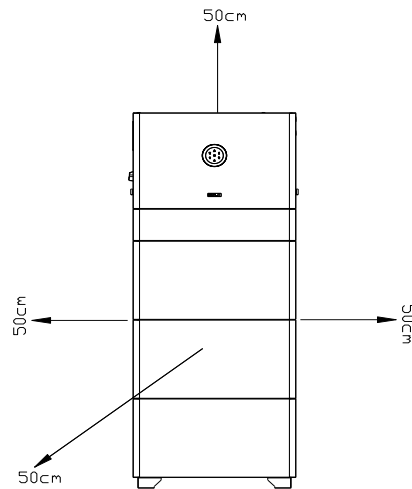

Figure 4.4. Installation clearance

4.3. Preparing Installation Tools

The tools illustrations are for your reference. Installation tools include but are not limited to the following recommended ones. Use other auxiliary tools based on site requirements.



Figure 4.5. Suggested installation tools

4.4. Unpacking

4.4.1. Checking the Outer Packing

Although SAJ's products have thoroughly tested and checked before delivery, there is possibility that the products may suffer damages during transportation.

1. Check the outer packing package for any damage, such as holes and cracks.
2. Check the equipment model.

If any serious damage is found or the model is not what you requested, do not unpack the product, and contact your dealer as soon as possible.

4.4.2. Checking the Package Contents

1. Verify that the shipment contains everything that you expected to receive. Contact after sales if there are missing or damaged components.
2. Place the accessories separately after unpacking to avoid confusion for connection of cables.

Contents in your shipment are order-dependent. Not all packages listed below may be in your shipment.

■ **Inverter package**

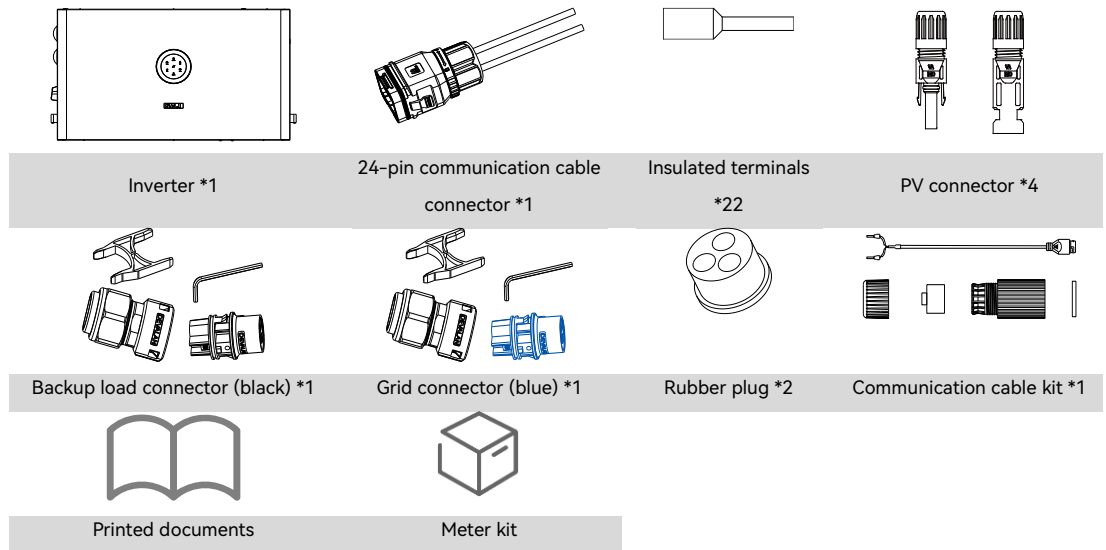

Notes:

- The printed documents include a warranty card, a Quick Guide, and a Configuration Instructions.
- This meter kit contains the following items:

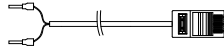

Communication cable with an RJ45 connector *1

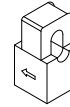

Current transformer *1



Smart meter *1

■ **Package of type A BU3 battery pack**

Type A battery has two holes on the left and right sides.

- Battery pack with a base (BU3-5.0-(TV1, TV2)-BASE or BU3-5.0-(TV1, TV2)-PRO-BASE)

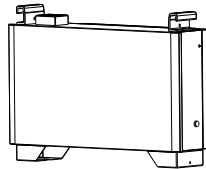

Battery module *1

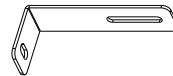

Locking bracket *2

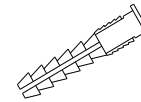

M6*80 expansion bolt *2

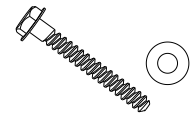

M6*50 screw *2
Gasket *2

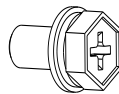

M5*14 screw *4

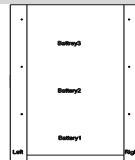

Cardboard *1

- (Optional) Battery without a base (BU3-5.0-(TV1, TV2) or BU3-5.0-(TV1, TV2)-PRO)

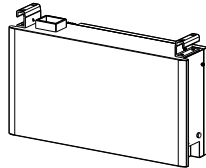

Battery module *1

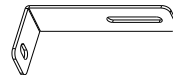

Locking bracket *2

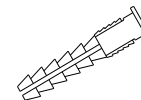

M6*80 expansion bolt *2

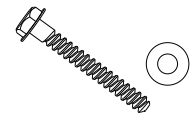

M6*50 screw *2
Gasket *2

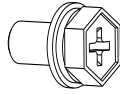

M5*14 screw *4

■ **Package of type B BU3 battery pack**

Type B battery pack has two mounting ears on the rear cover.

- Battery pack with a base (BU3-5.0-(TV1, TV2)-BASE or BU3-5.0-(TV1, TV2)-PRO-BASE)

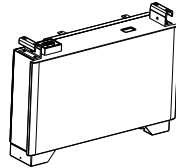

Battery module *1



Locking bracket *2

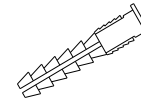

M6*80 expansion bolt *2

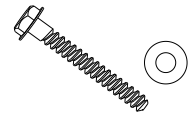

M6*50 screw *2
Gasket *2

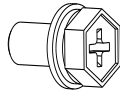

M5*14 screw *4

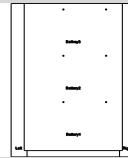

Cardboard *1



M4*12 screw *1
(For Australia)



Grounding plate*1
(For Australia)

- (Optional) Battery without a base (BU3-5.0-(TV1, TV2) or BU3-5.0-(TV1, TV2)-PRO)

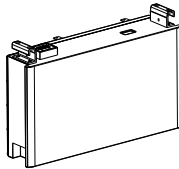

Battery module *1



Locking bracket *2

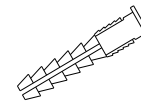

M6*80 expansion bolt *2

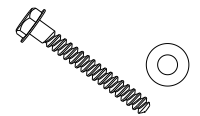

M6*50 screw *2
Gasket *2

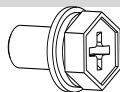

M5*14 screw *4



M4*12 screw *2
(For Australia)



Grounding plate*1
(For Australia)

■ **Wall-mounting bracket**

This is an optional package, depending on your system configuration.

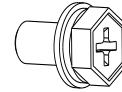
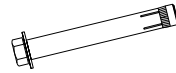
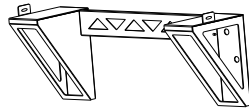

Mounting bracket *

M12*100 expansion bolt *6

M5*14 screw *2

■ **BC3 Battery Junction Box Package**

This is an optional package, depending on your system configuration.

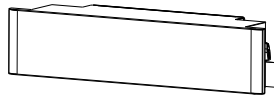

Battery junction box *1

Communication cable *1

Positive cable *1
Negative cable *1
(For Europe)

Positive cable *1
Negative cable *1
(For Australia)

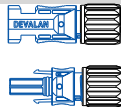

Positive connector *1
Negative connector *1
(For Australia)



M4*12 screw *2
(For Australia)

■ **CU2 Charger Package**

This is an optional package, depending on your system configuration.

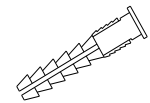
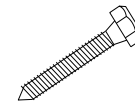
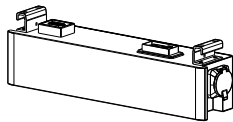

Charger *1

Holster *1

M4*32 screw *4

Expansion bolt *4

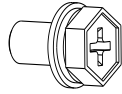

M5*14 screw *2

4.5. Installation

Depending on your order, you will receive either type A or type B battery pack.

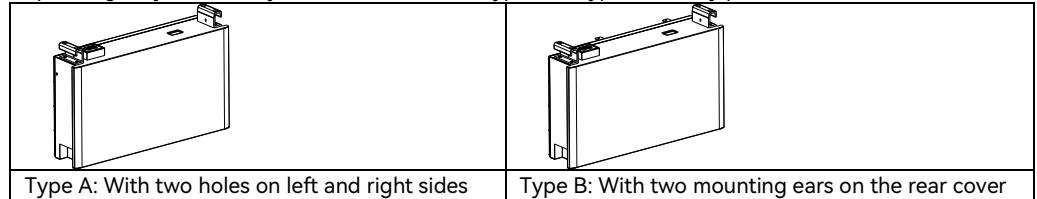

Depending on the battery pack type and mounting manner, choose the following installation procedure:

- Section 4.5.1 "Type A battery pack: ground mounting manner" on Page 40
- Section 4.5.2 "Type B battery pack: ground mounting manner" on Page 50
- Section 4.5.3 "Type B Battery Pack: wall mounting manner" on Page 61

4.5.1. Type A battery pack: ground mounting manner

Before you start

Make sure that the ground should be flat and no inclination.

Procedure

Step 1. Install the base battery (BU3-5.0-(TV1, TV2)-BASE or BU3-5.0-(TV1, TV2)-PRO-BASE).

- a. Get the cardboard from the base battery package. Place the cardboard on to the wall. Drill six holes (8 mm in diameter and 55 mm in depth) on the marked positions on the cardboard. Install the provided expansion bolts into the drilled holes.

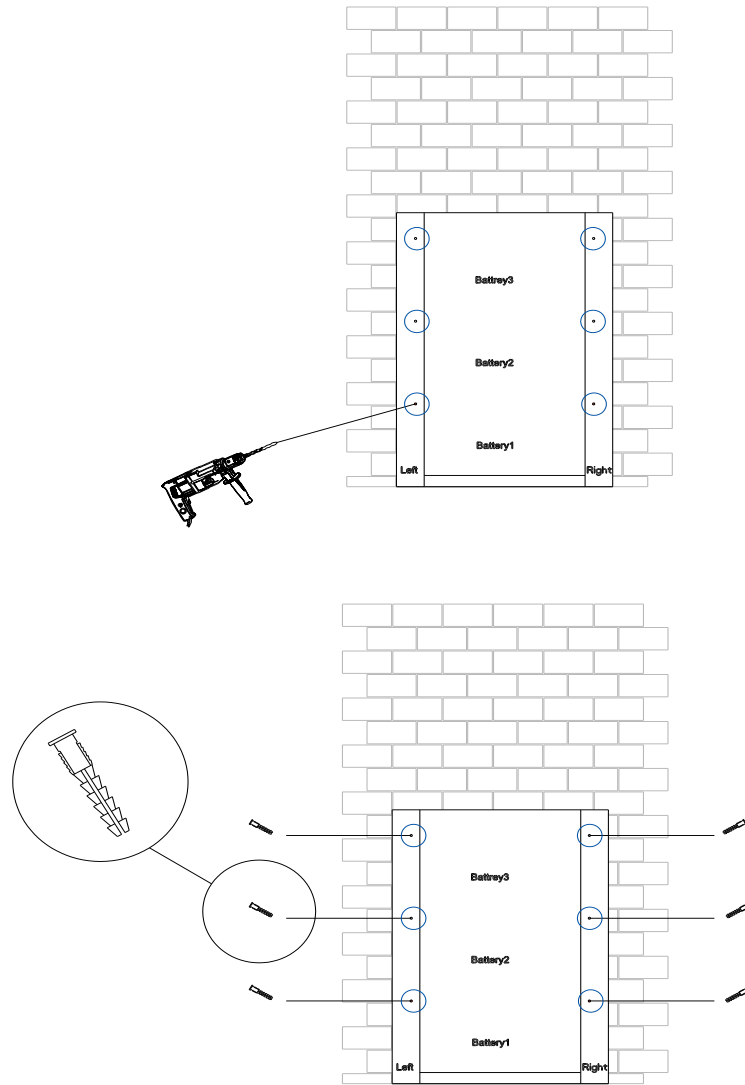

Figure 4.6. Marking and drilling holes on the wall

- b. Use two M5*14 screws to install two locking brackets on the left and right sides of the battery pack. On the desired installation site, place the base battery on the floor. Make sure that:
- The left and right battery bases are aligned with the vertical black lines on the cardboard.
 - The battery pack is placed horizontally. (It is recommended that a gradienter be used.)
 - The space between the battery back and the wall surface is 50–65 mm.

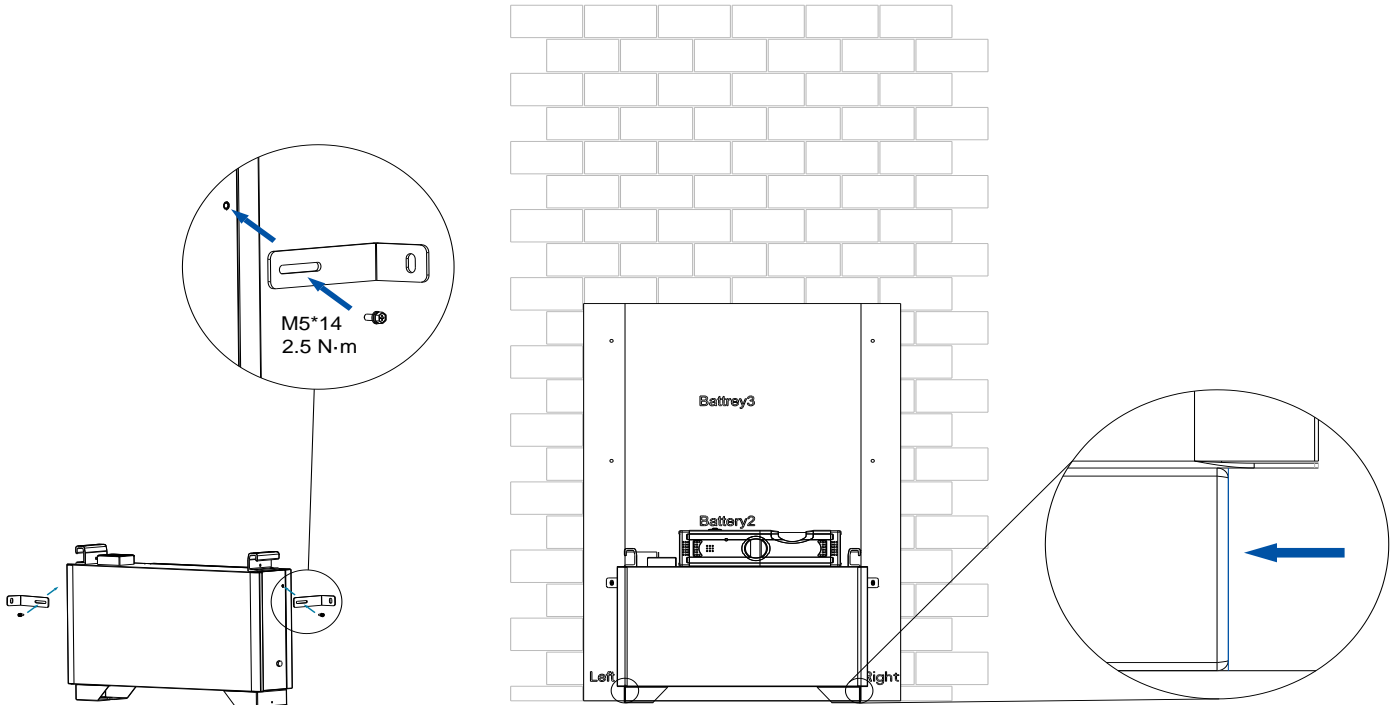

Figure 4.7. Installing the battery with the base

- c. On the left and right upper sides of the battery pack, align the locking brackets to the drill holes and install M6*50 screws to secure the locking brackets to the wall.
- Note:** If the battery is installed outdoors, it is suggested to remove the cardboard which is not waterproof.

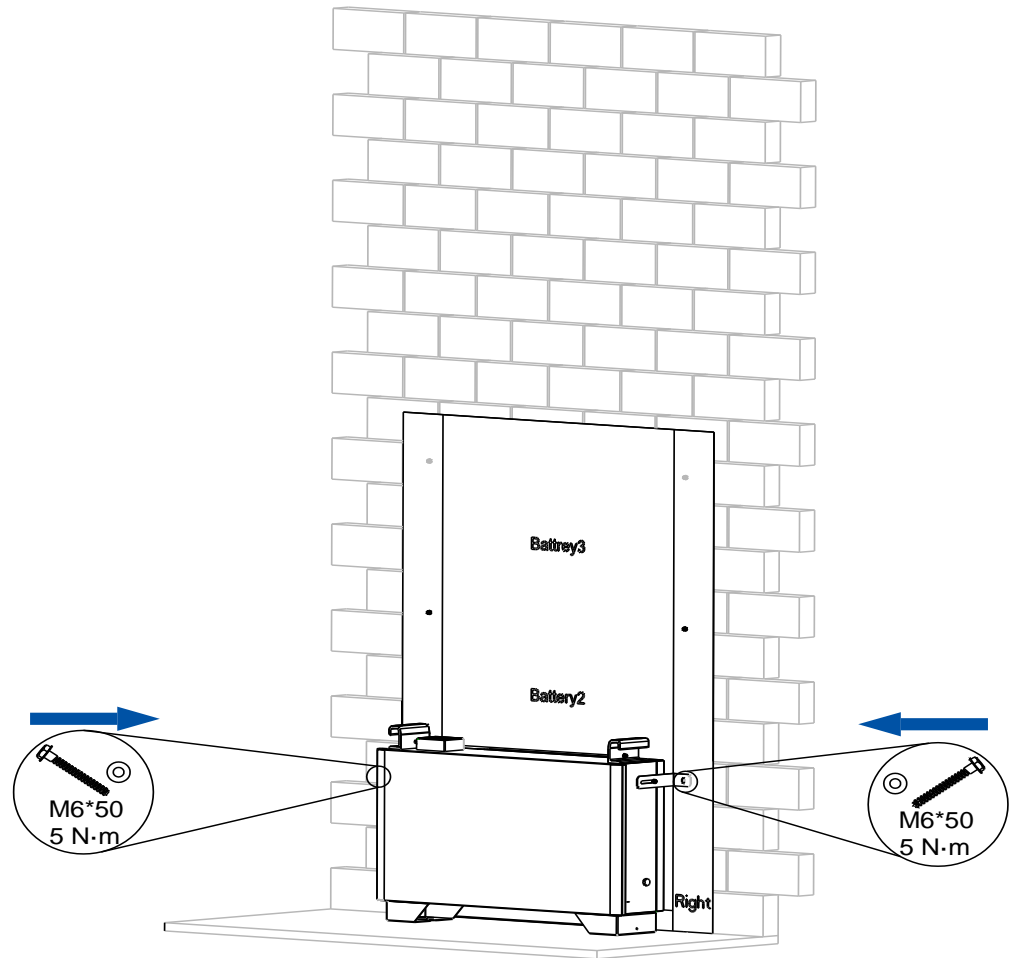

Figure 4.8. Securing the battery to the wall

Step 2. (Optional) Install other batteries (BU3-5.0-(TV1, TV2) or BU3-5.0-(TV1, TV2)-PRO).

Note: In one stack, up to three batteries are supported.

- a. Use two M5*14 screws to install two locking brackets on the left and right sides of the battery pack. Place this battery onto the base battery and push it downwards.

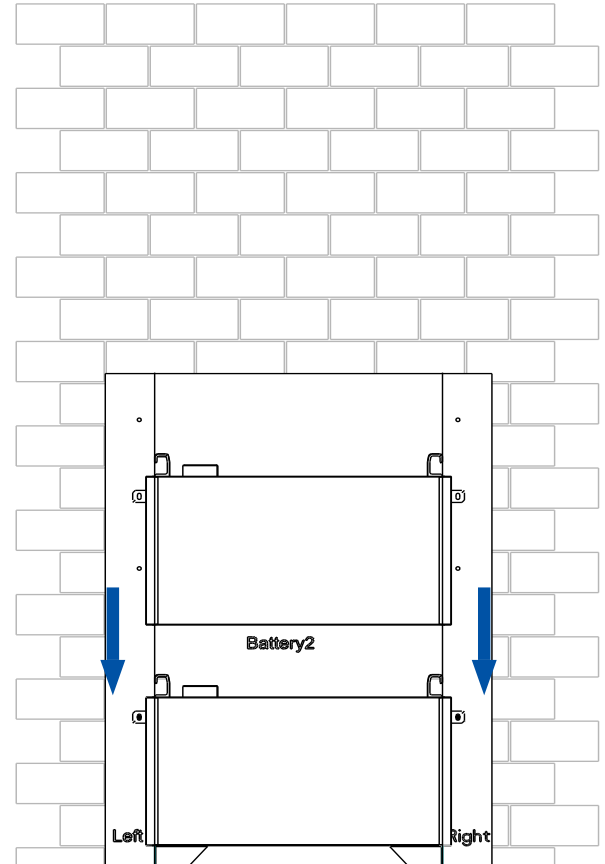
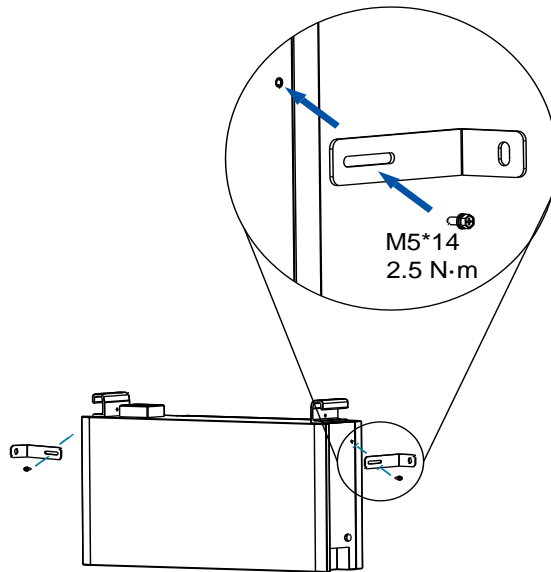

Figure 4.9. Installing the second battery

- b. On the left and right upper sides of the battery pack, align the locking brackets to the drilled holes and install the gaskets and M6*50 screws to secure the battery pack to the wall.
- On the left and right bottom sides of the battery pack: Install two M5*14 screws to secure two batteries.

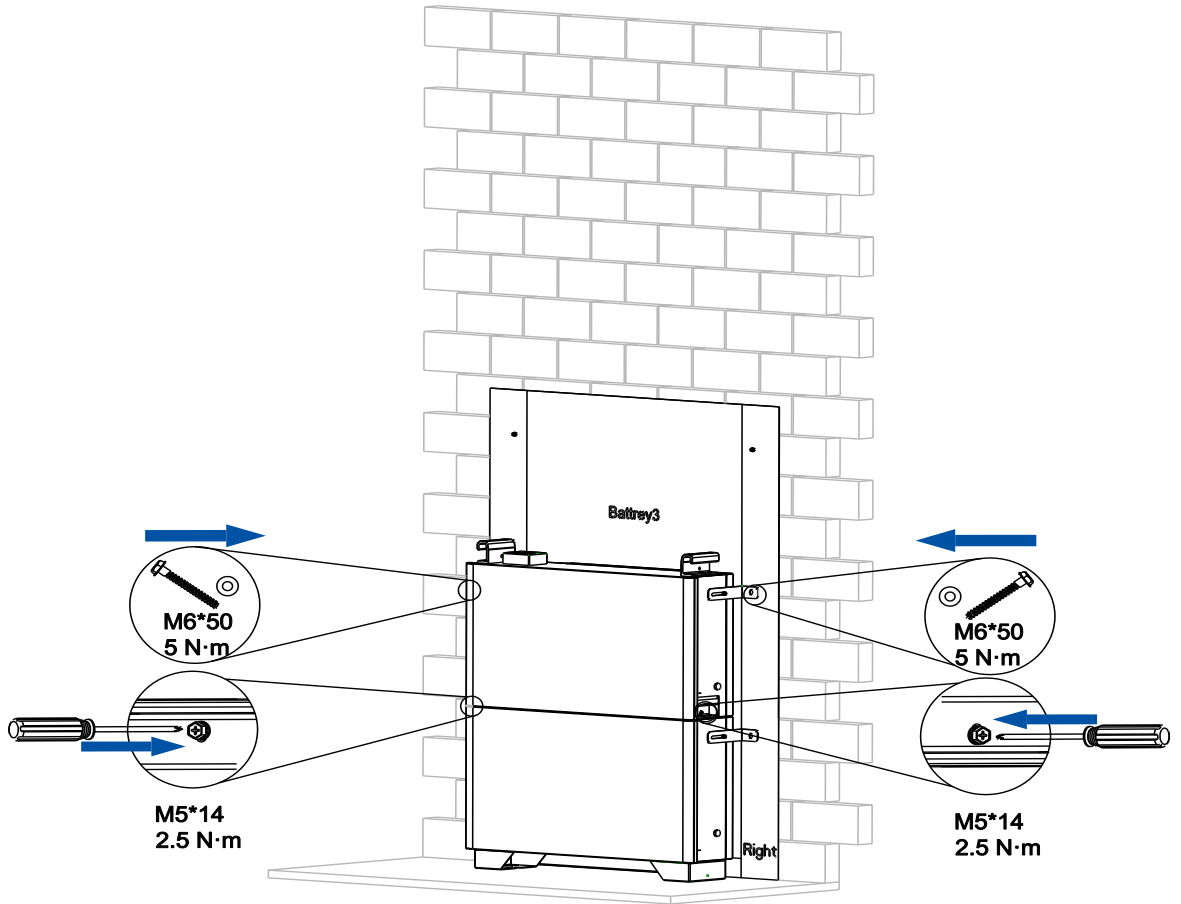

Figure 4.10. Securing the batteries

- a. (Optional) If needed, repeat steps a and b to install the third battery.

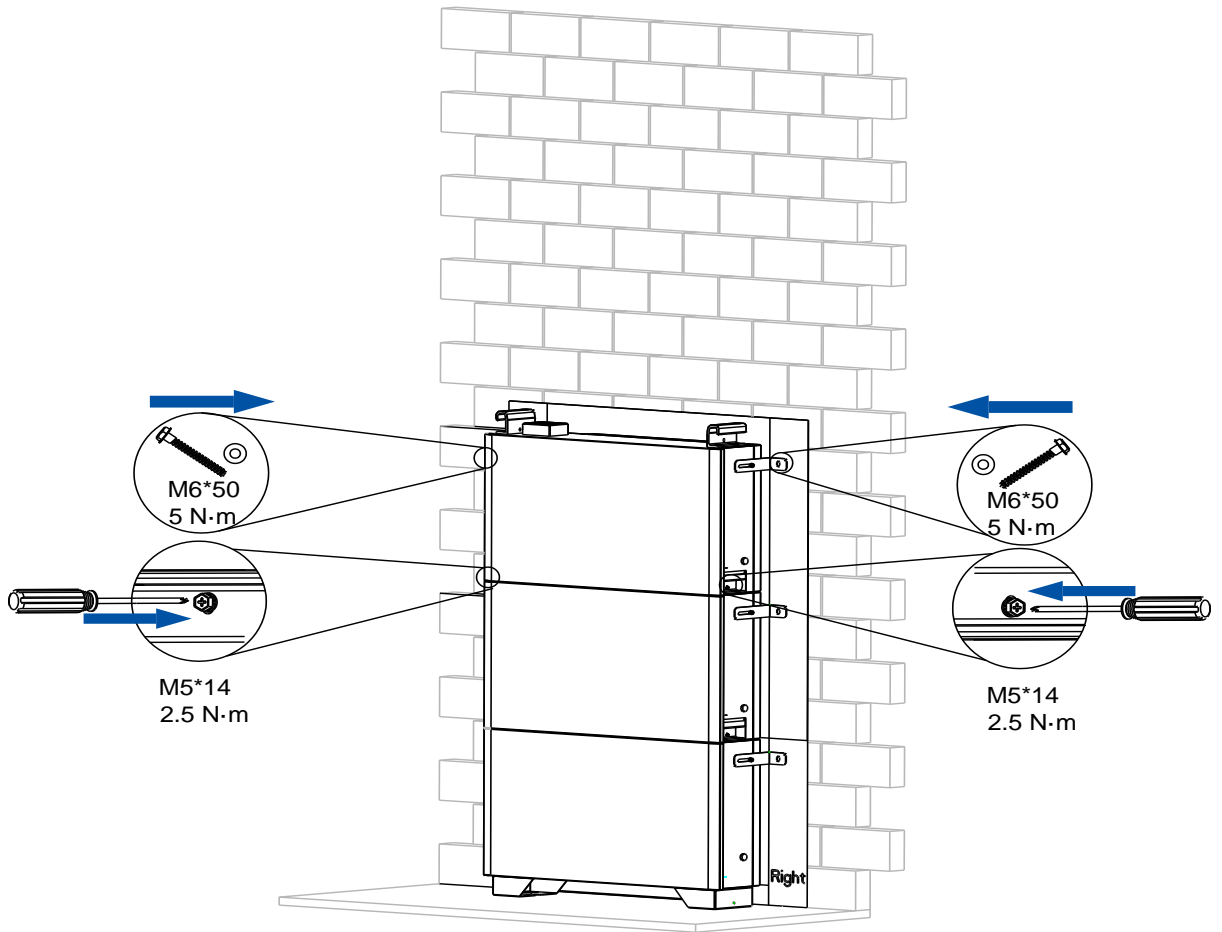

Figure 4.11. Installing the third battery

Step 3. (Optional) Install the charger (CU2-7.4K-S-I).

- a. Get the holster from the charger package. Install the holster onto the right side of the charger.
- b. Place the charger onto the battery. Push it downwards.
- c. Install M5*14 screws on both lower sides of the charger to secure the charger to the battery.

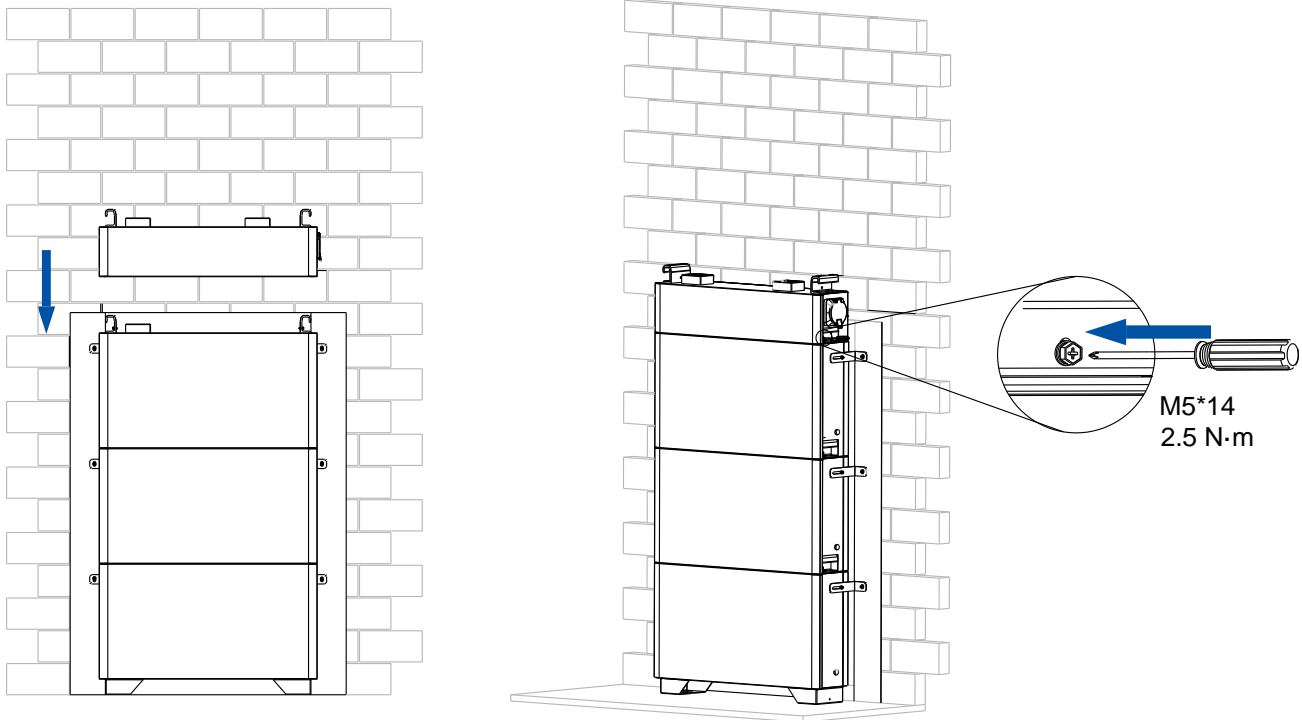

Figure 4.12. Installing the charger

- d. Install the holster on the wall by using three M4*32 screws.

Note: The holster is used to secure the charger cable. You can connect the cable after all installation is completed. It is recommended that you purchase the cable from SAJ.

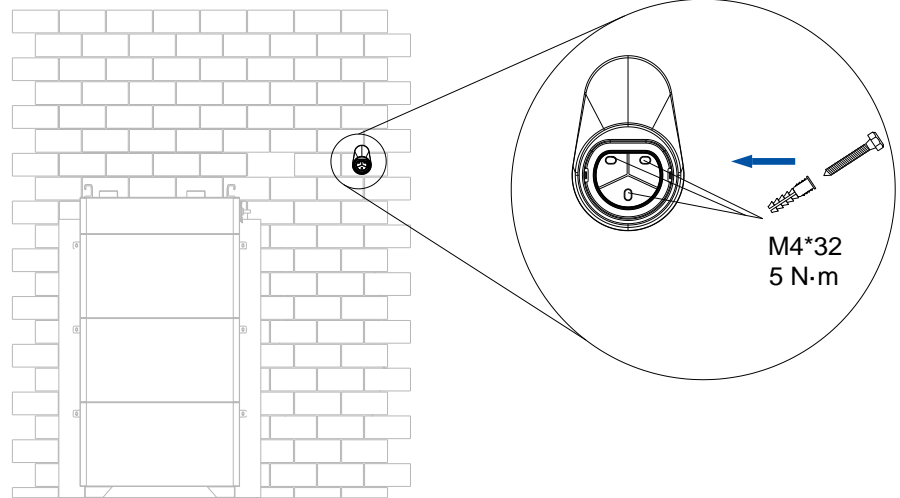

Figure 4.13. Installing the charger cable holster

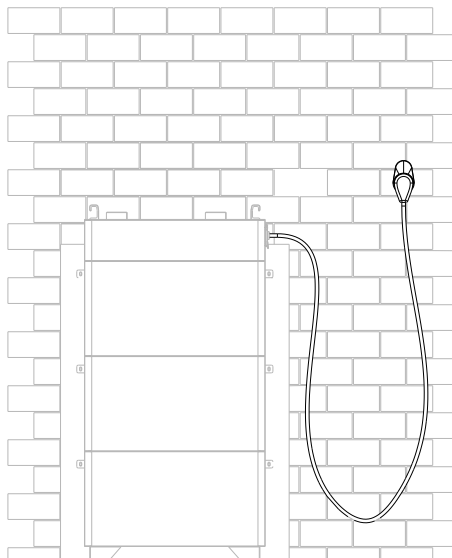
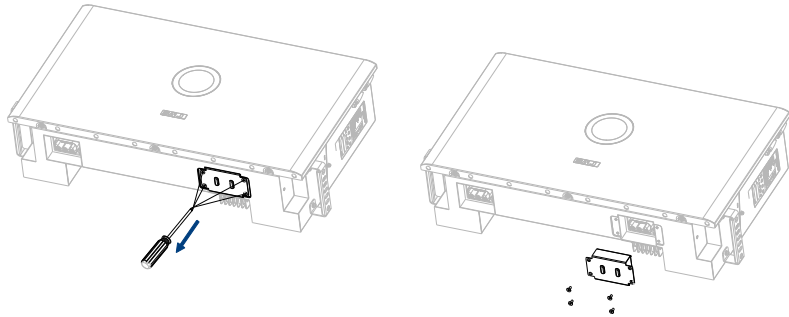

Figure 4.14. Connecting the charger cable

Step 4. Install the inverter (HS3-xk-S2-(W, G)-(B, P) or HS3-xK-S2-(W, G)-(B, P)-(BE, IE)).

- a. (Optional) If you have installed a charger, loosen the screws on the inverter, and remove the port cover, as shown below:



- b. Place the inverter onto the battery or charger (if available) and push it downwards. Install screws on both lower sides of the inverter to secure the inverter to the beneath device (battery or charger; here takes a charger as an example).

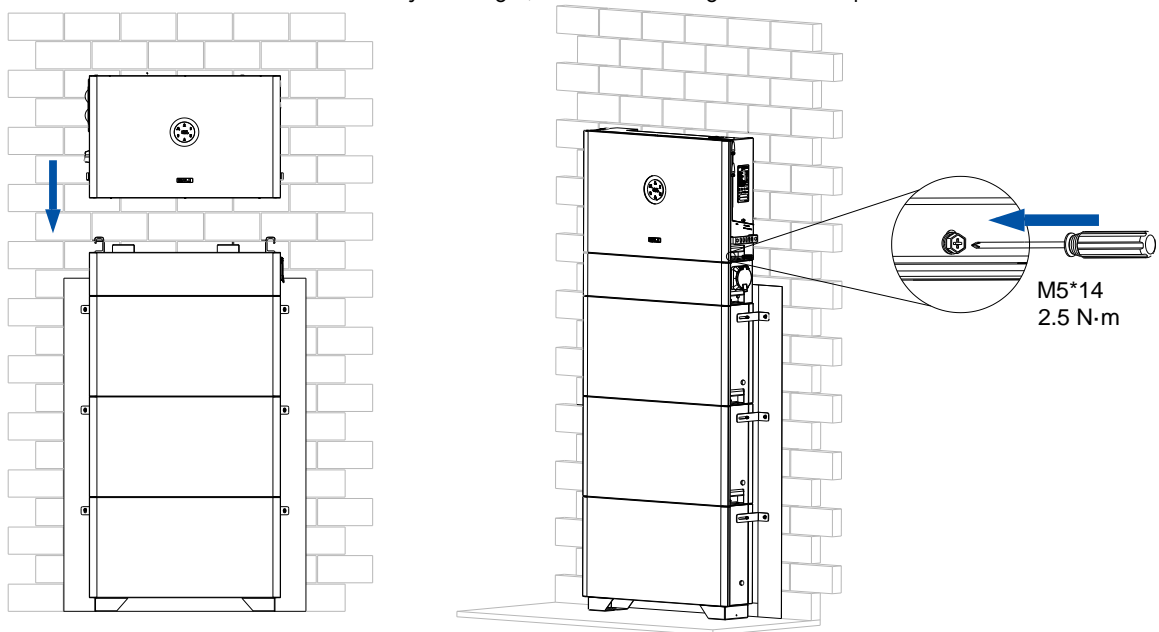
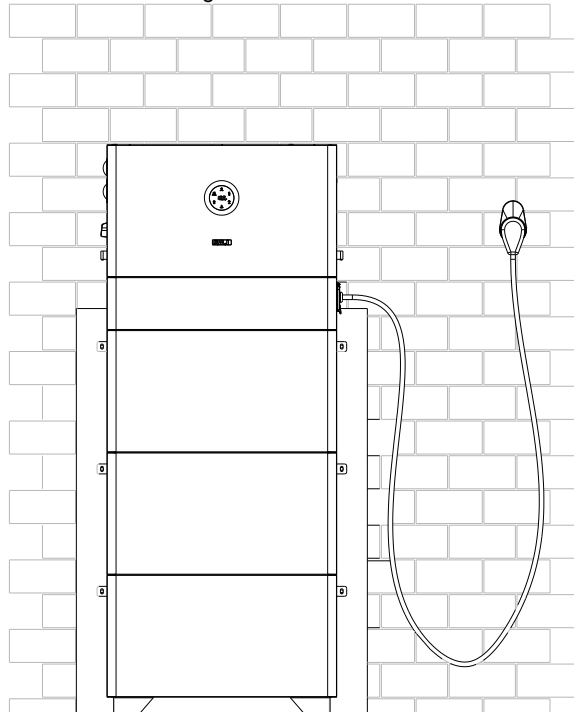

Figure 4.15. Installing the inverter

Installation completion view

Single stack: supporting 1 to 3 batteries

Example of 3 batteries:
Inverter + charger + batteries



Inverter + batteries

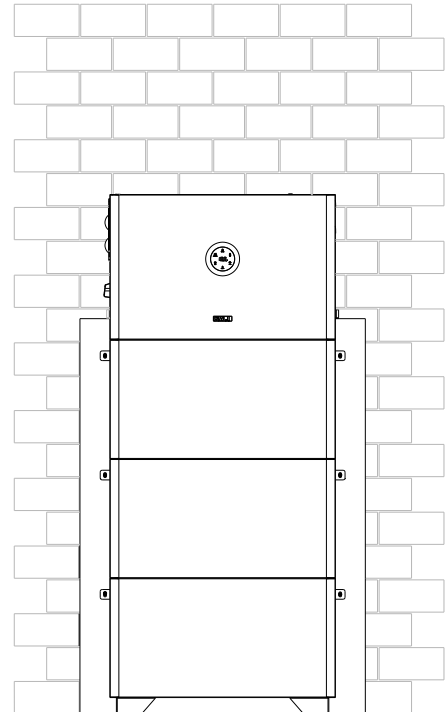

Figure 4.16. Completion view of a single stack

4.5.2. Type B battery pack: ground mounting manner

Before you start

Make sure that the ground should be flat and no inclination.

Procedure

Step 1. Install the base battery (BU3-5.0-(TV1, TV2)-BASE or BU3-5.0-(TV1, TV2)-PRO-BASE).

- a. Get the cardboard from the base battery package. Place the cardboard on to the wall. Drill six holes (8mm in diameter and 55mm in depth) on the marked positions on the cardboard. Install the provided expansion bolts into the drilled holes.

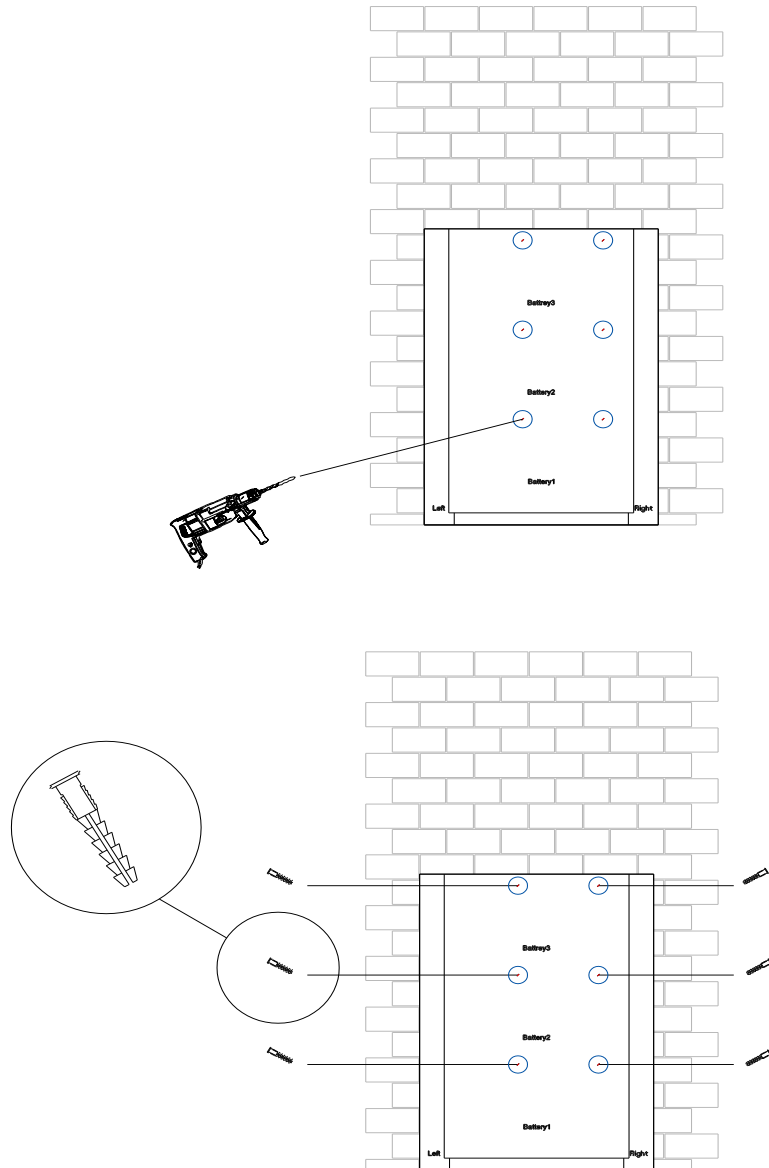

Figure 4.17. Marking and drilling holes on the wall

- b. Use two M5*14 screws to install two locking brackets to the mounting ears on the top of the battery pack. On the desired installation site, place the base battery on the floor. Make sure that:
- The left and right battery bases are aligned with the vertical black lines on the cardboard.
 - The battery pack is placed horizontally. (It is recommended that a gradienter be used.)
 - The space between the battery back and the wall surface is 40–50 mm.

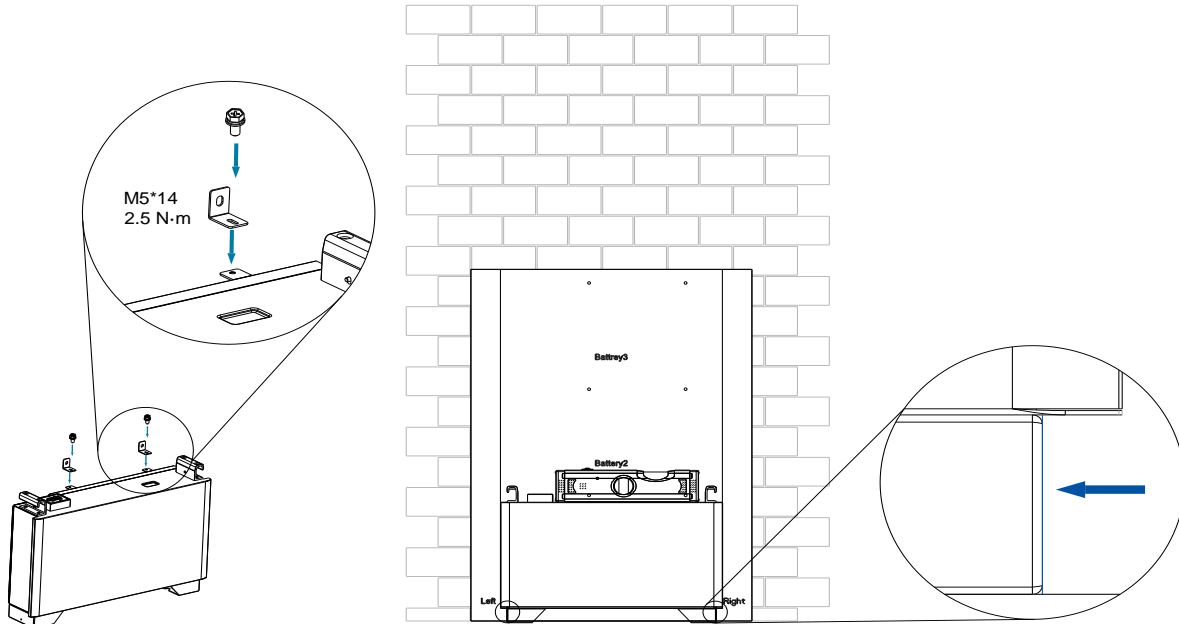

Figure 4.18. Installing the battery with the base

- c. On the top of the battery pack, align the locking brackets to the drilled holes and install M6*50 screws to secure the locking brackets to the wall.
- Note:** If the battery is installed outdoors, it is suggested to remove the cardboard which is not waterproof.

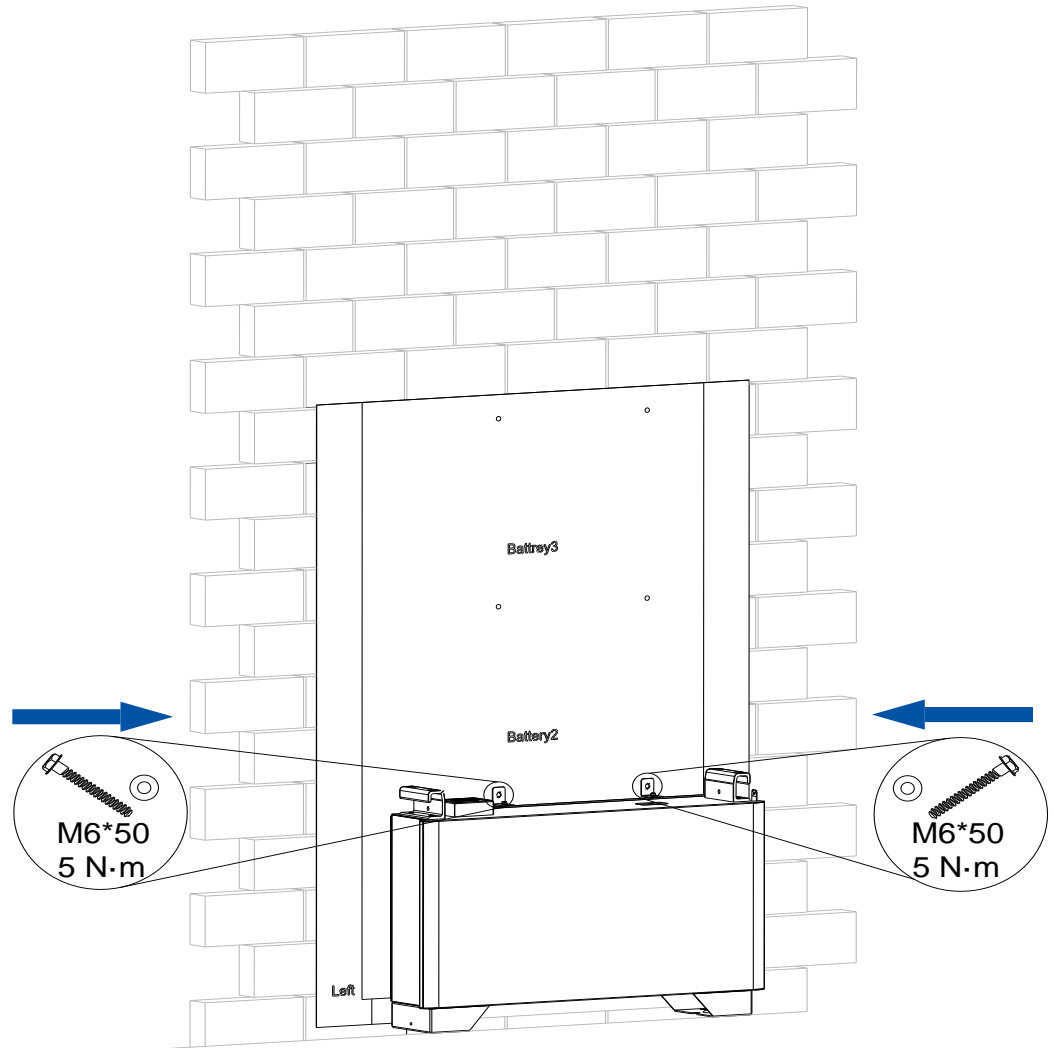

Figure 4.19. Securing the battery to the wall

Step 2. (Optional) Install other batteries (BU3-5.0-(TV1, TV2) or BU3-5.0-(TV1, TV2)-PRO).

Note: In one stack, up to three batteries are supported.

- a. Use two M5*14 screws to install two locking brackets to the mounting ears on the top of the battery pack. Place this battery onto the base battery and push it downwards.

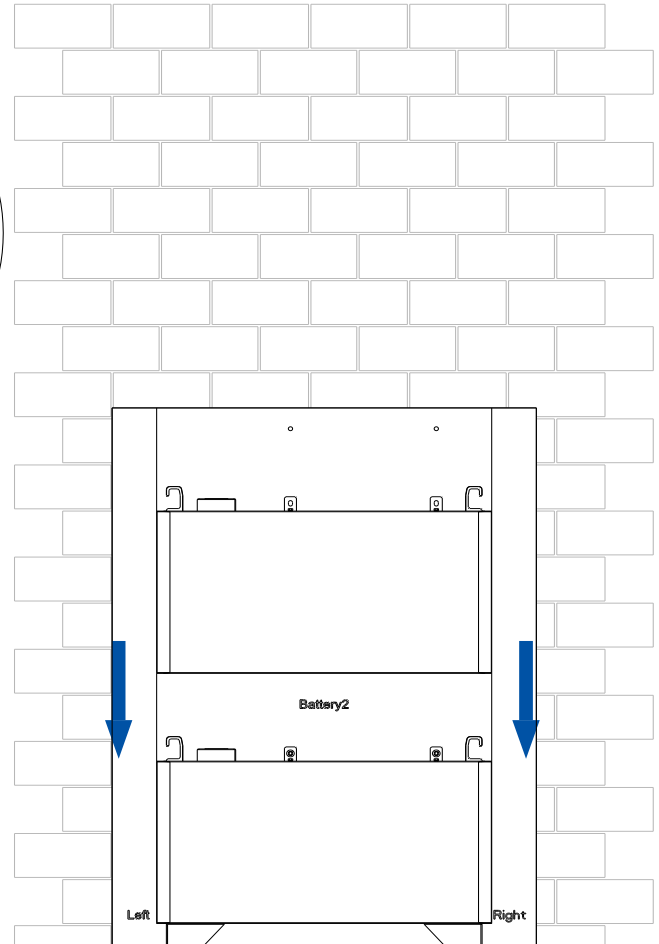
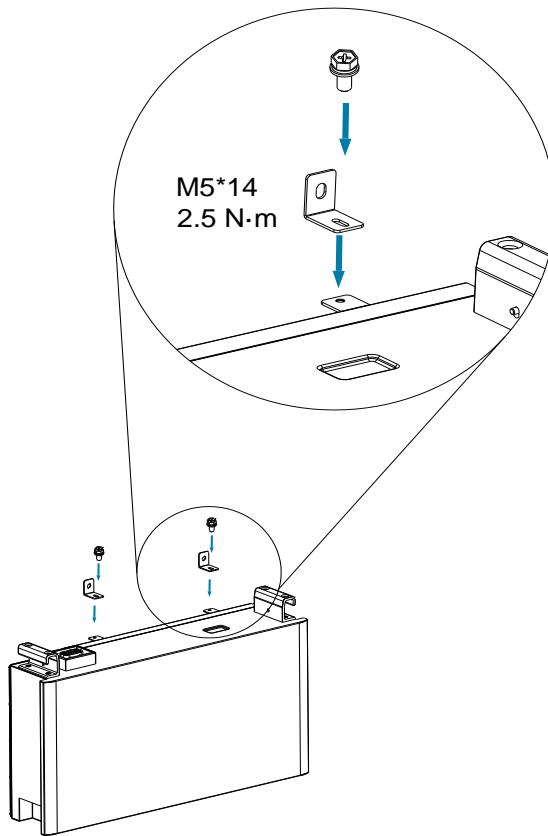

Figure 4.20. Installing the second battery

- b. On the top of the battery pack, align the locking brackets to the drilled holes and install the gaskets and M6*50 screws to secure the battery pack to the wall.

On the left and right bottom sides of the battery pack, install M5*14 screws to secure two batteries.

Australia only: As shown in the right figure, install the metal grounding plate and secure it by installing two M4*12 screws.

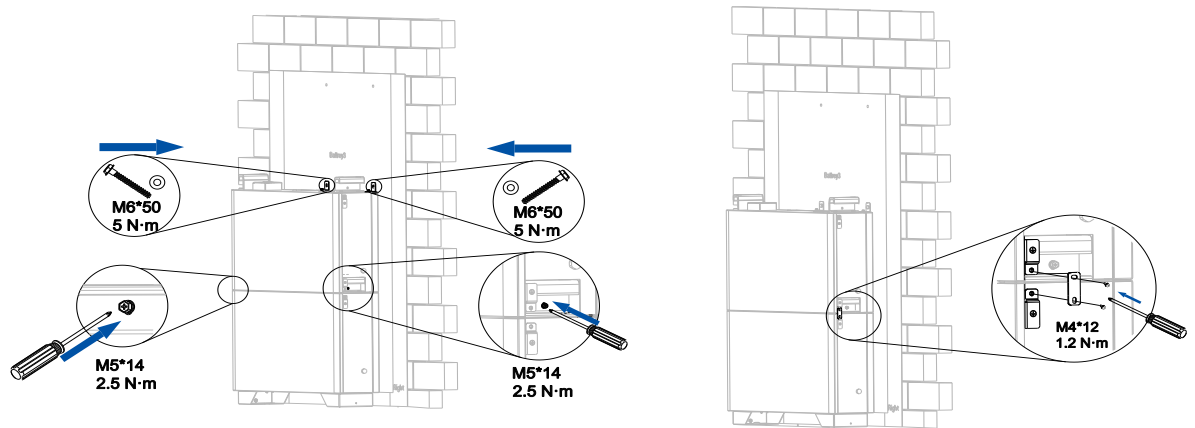

Figure 4.21. Securing the batteries

- c. (Optional) If needed, repeat steps a and b to install the third battery.

Australia only: Install the metal grounding plate and secure it by installing two M4*12 screws.

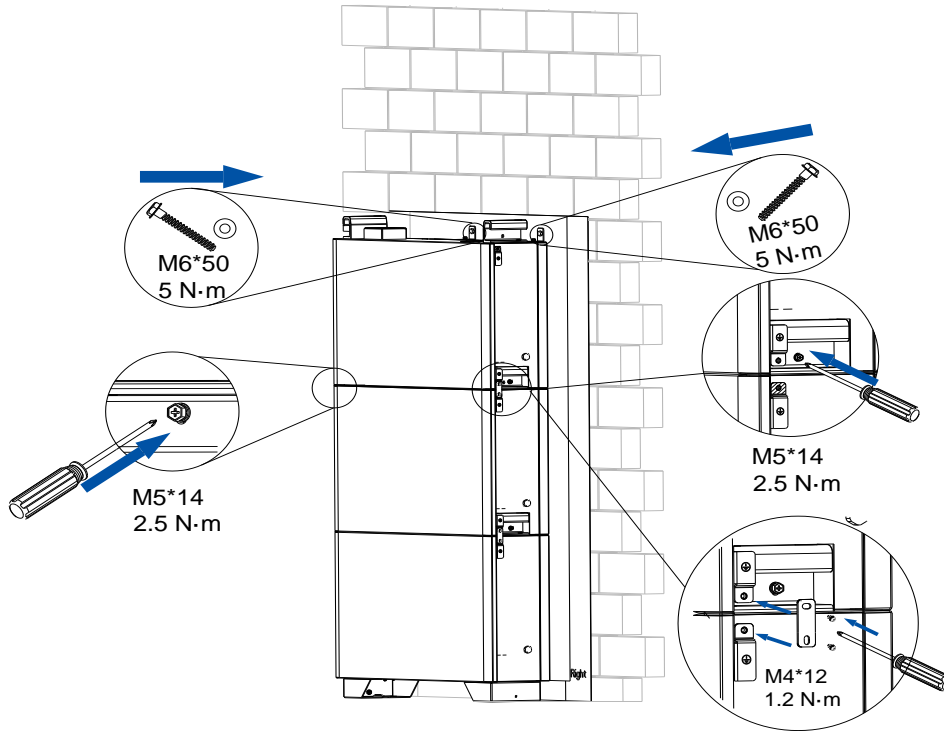

Figure 4.22. Installing the third battery

Step 3. (Optional) Install the charger (CU2-7.4K-S-I).

- a. Get the holster from the charger package. Install the holster onto the right side of the charger.
- b. Place the charger onto the battery. Push it downwards.
- c. On the left and right bottom sides, install M5*14 screws to secure the charger to the battery.

Australia only: As shown in the right figure, install the metal grounding plate and secure it by installing two M4*12 screws.

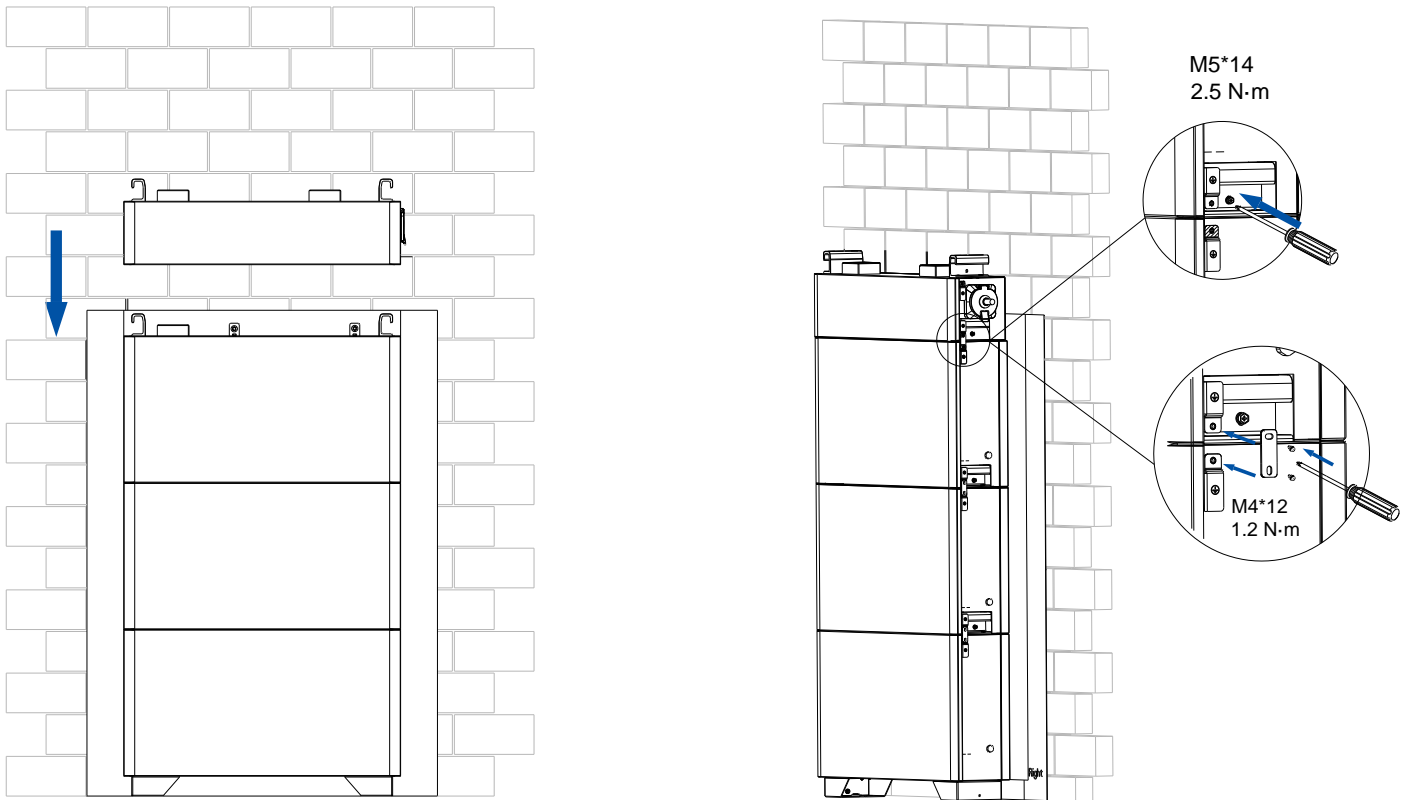

Figure 4.23. Installing the charger

- d. Install the holster on the wall by using three M4*32 screws.

Note: The holster is used to the charger cable. You can connect the cable after all installation is completed. It is recommended that you purchase the cable from SAJ.

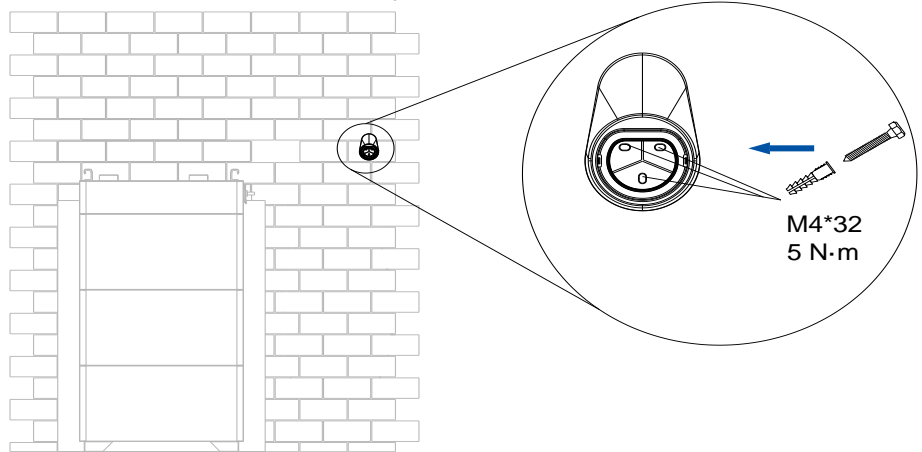

Figure 4.24. Installing the charger cable holster

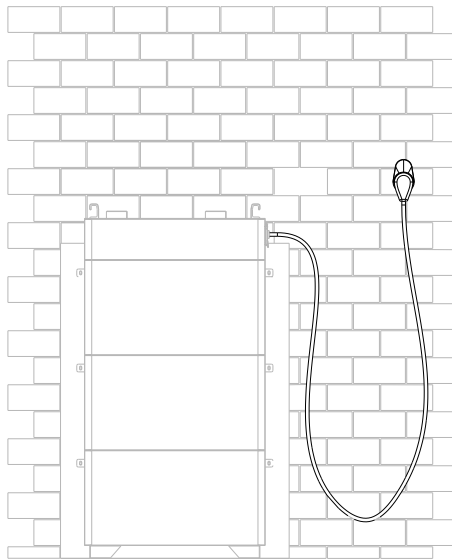
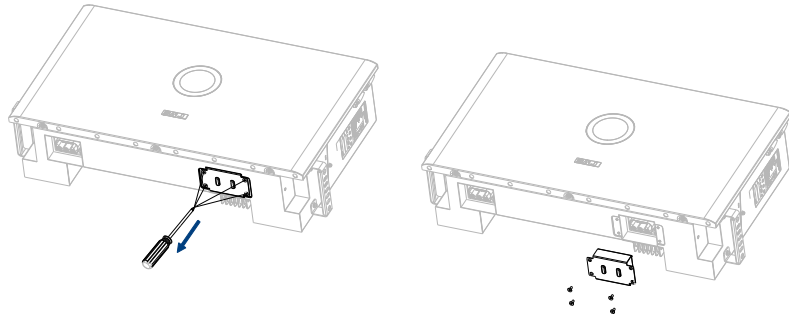

Figure 4.25. Connecting the charger cable

Step 4. Install the inverter (HS3-xk-S2-(W, G)-(B, P) or HS3-xK-S2-(W, G)-(B, P)-(BE, IE)).

- c. (Optional) If you have installed a charger, loosen the screws on the inverter, and remove the port cover, as shown below:



- d. Place the inverter onto the battery or charger (if available) and push it downwards. On the left and right bottom sides of the inverter, install M5*14 screws to secure the inverter to the beneath device.

Australia only: Install the metal grounding plate and secure it by installing two M4*12 screws.

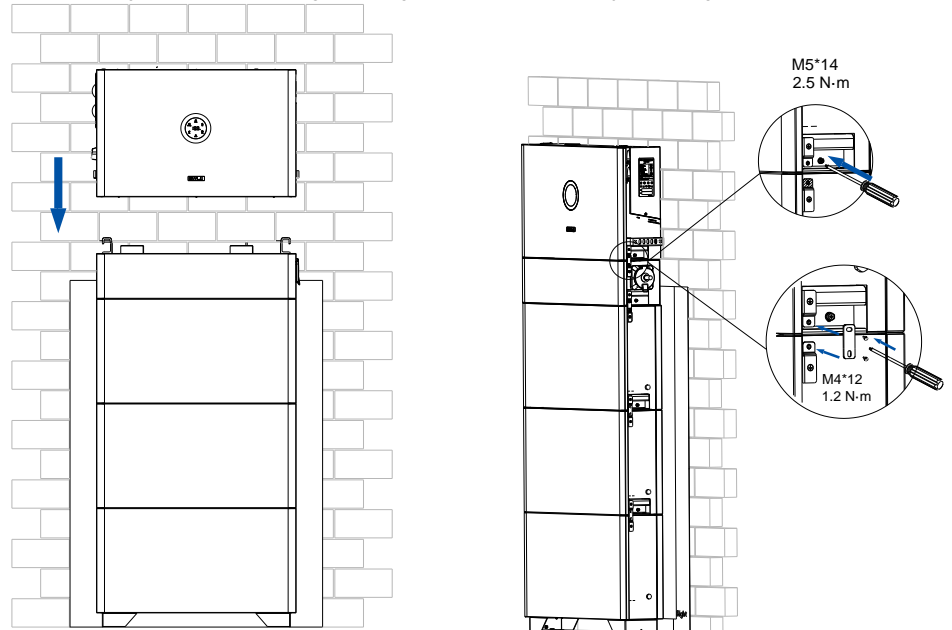
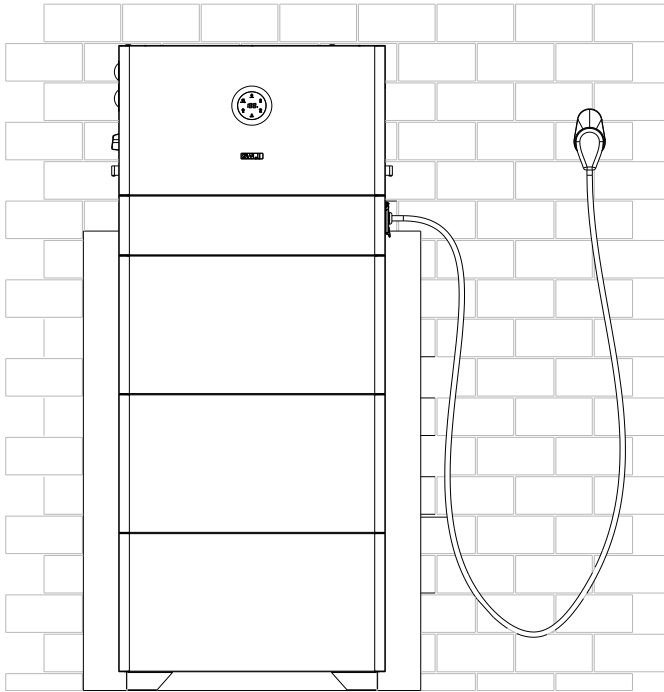

Figure 4.26. Installing the inverter

Installation completion view**Single stack: supporting 1 to 3 batteries**

Example of 3 batteries:

Inverter + charger + batteries



Inverter + batteries

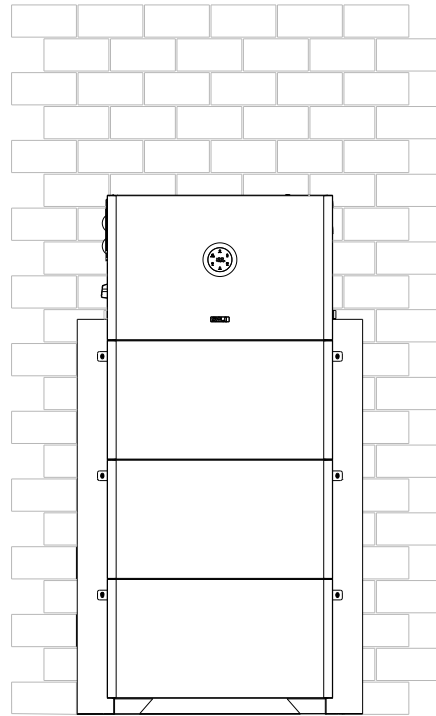

Figure 4.27. Completion view of a single stack

4.5.3. Type B Battery Pack: wall mounting manner

Before you start

Make sure that the wall can bear the weight of the inverter and accessories.

Procedure

Step 1. Install the wall-mounting bracket.

- a. Place the mounting bracket onto the wall. Mark six holes. Remove the bracket.

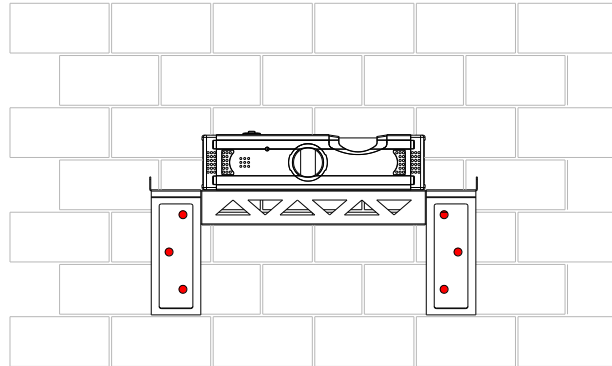

Figure 4.28. Marking the hole positions

- b. Drill six holes according to the marked positions on the wall.

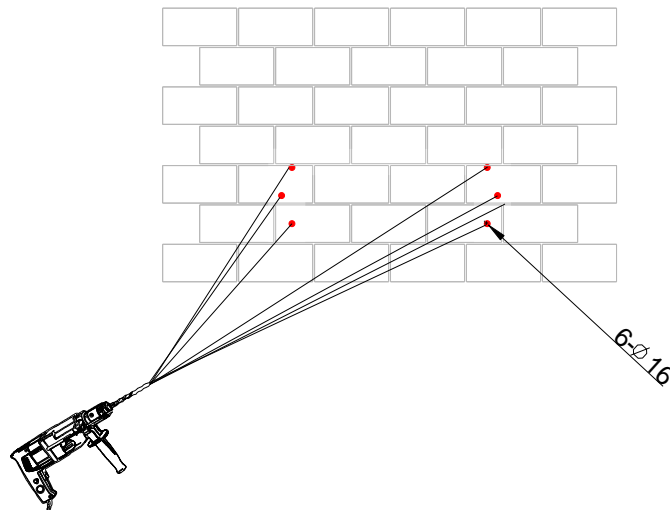

Figure 4.29. Drilling holes

- c. Install the mounting bracket on to the wall.

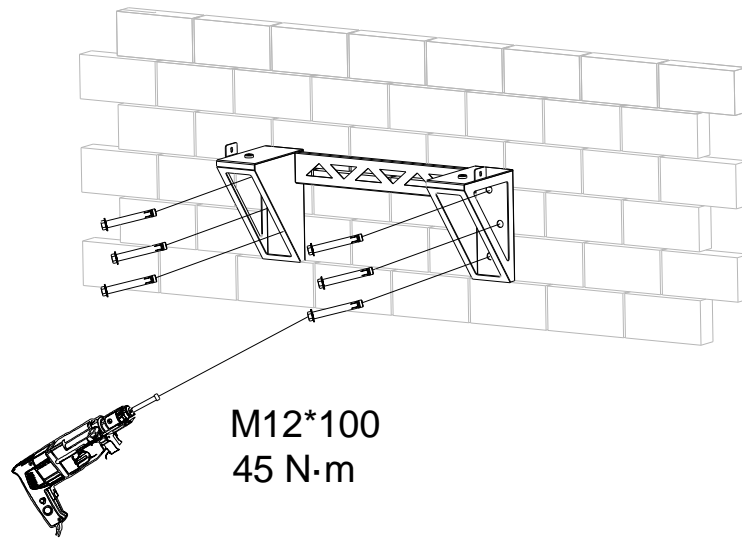

Figure 4.30. Installing the mounting bracket

Step 1. Install the base battery (BU3-5.0-(TV1, TV2)-BASE or BU3-5.0-(TV1, TV2)-PRO-BASE).

- a. Get the cardboard from the base battery package. Place the cardboard onto the wall and align the vertical lines on the cardboard with the bracket edges.

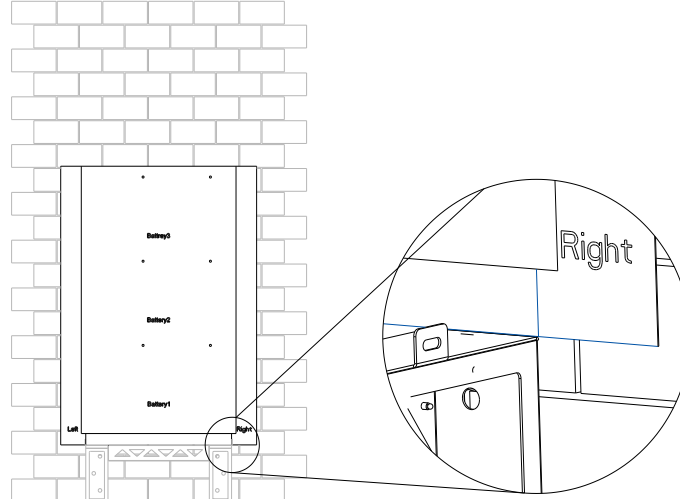

Figure 4.31. Aligning the cardboard with the bracket

- b. Drill six holes (8mm in diameter and 55mm in depth) on the marked positions on the cardboard. Install the provided expansion bolts into the drilled holes.

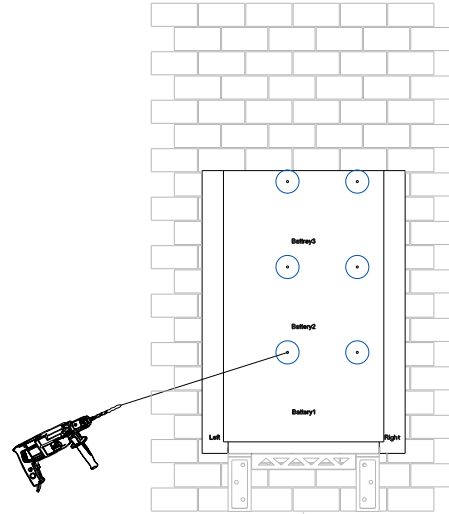

Figure 4.32. Drilling holes

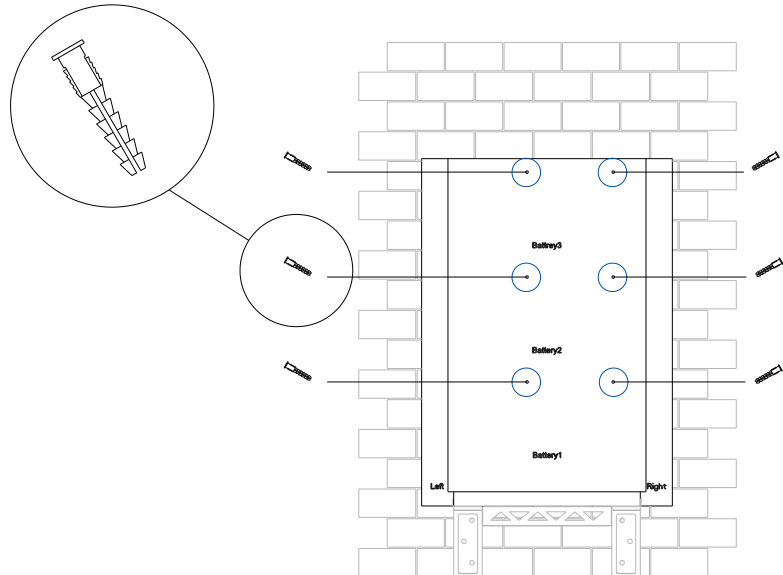

Figure 4.33. Installing expansion bolts

- c. Use two M5*14 screws to install two locking brackets to the mounting ears on the top of the battery pack. Place the base battery onto the floor. Make sure that:
- The battery feet are aligned with the vertical black line on the cardboard.
 - The battery pack is placed horizontally. (It is recommended that a gradienter be used.)
 - The space between the battery back and the wall surface is 40–50 mm.

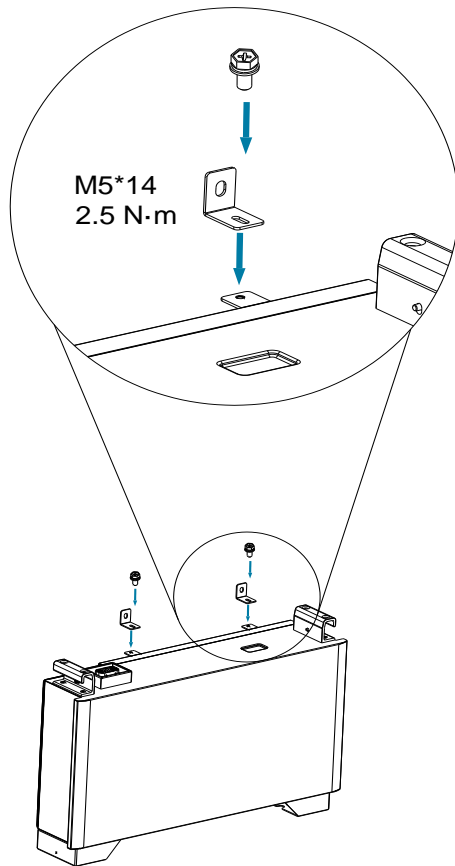
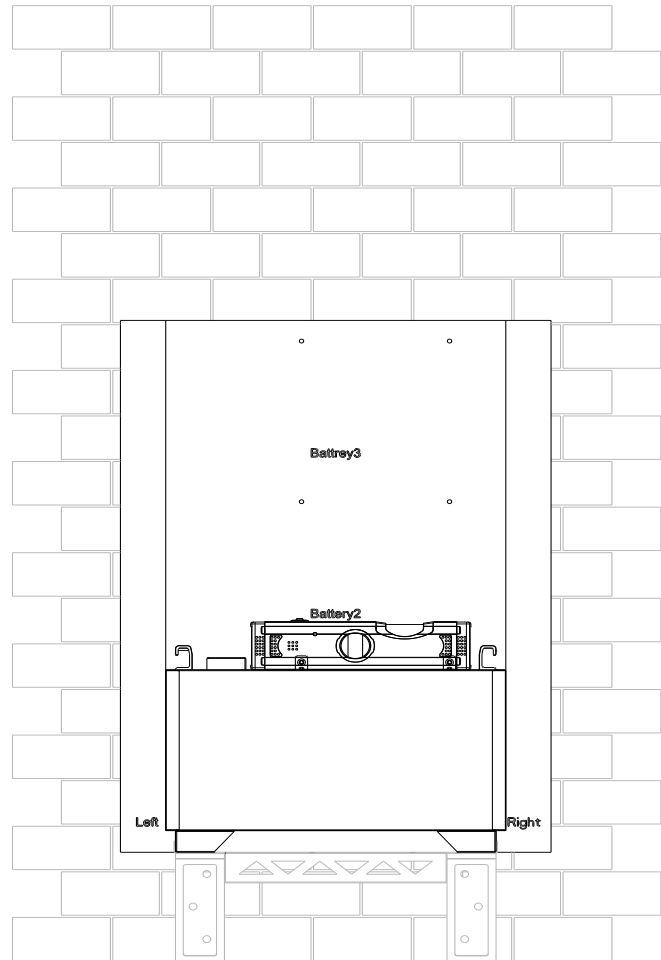

Figure 4.34. Installing the battery with the base



- d. On the top of the battery pack, align the locking brackets to the drilled holes and install M6*50 screws to secure the locking brackets to the wall. Secure battery to the bracket by tightening two M6*14 screws.

Note: If the battery is installed outdoors, it is suggested to remove the cardboard which is not waterproof.

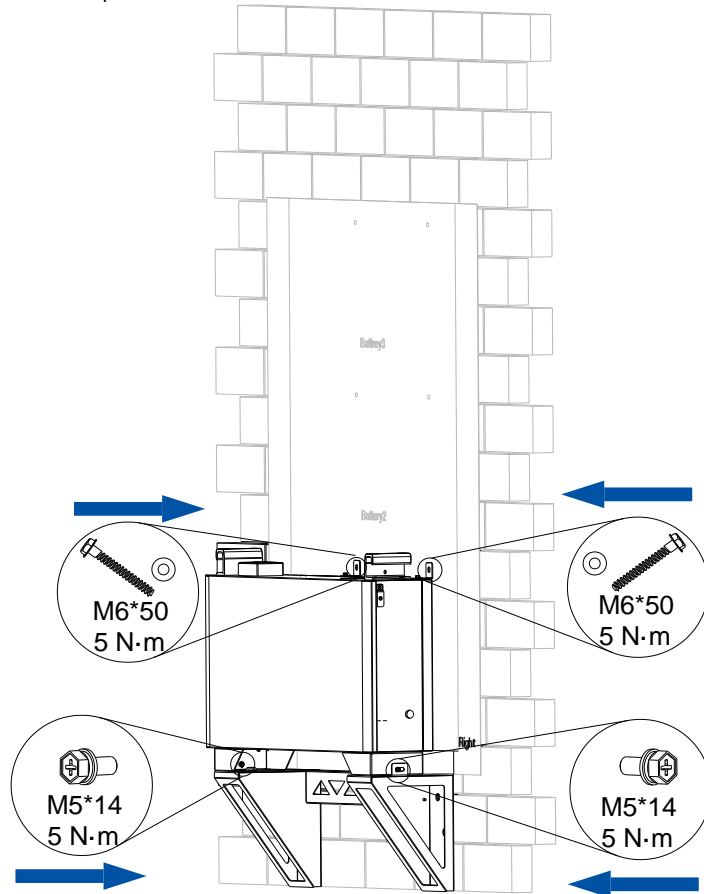

Figure 4.35. Securing the battery to the wall

Step 2. Install other batteries (BU3-5.0-(TV1, TV2) or BU3-5.0-(TV1, TV2)-PRO).

Note: In one stack, up to three batteries are supported.

- a. Use two M5*14 screws to install two locking brackets to the mounting ears on the top of the battery pack. Place this battery onto the base battery. Push it downwards.

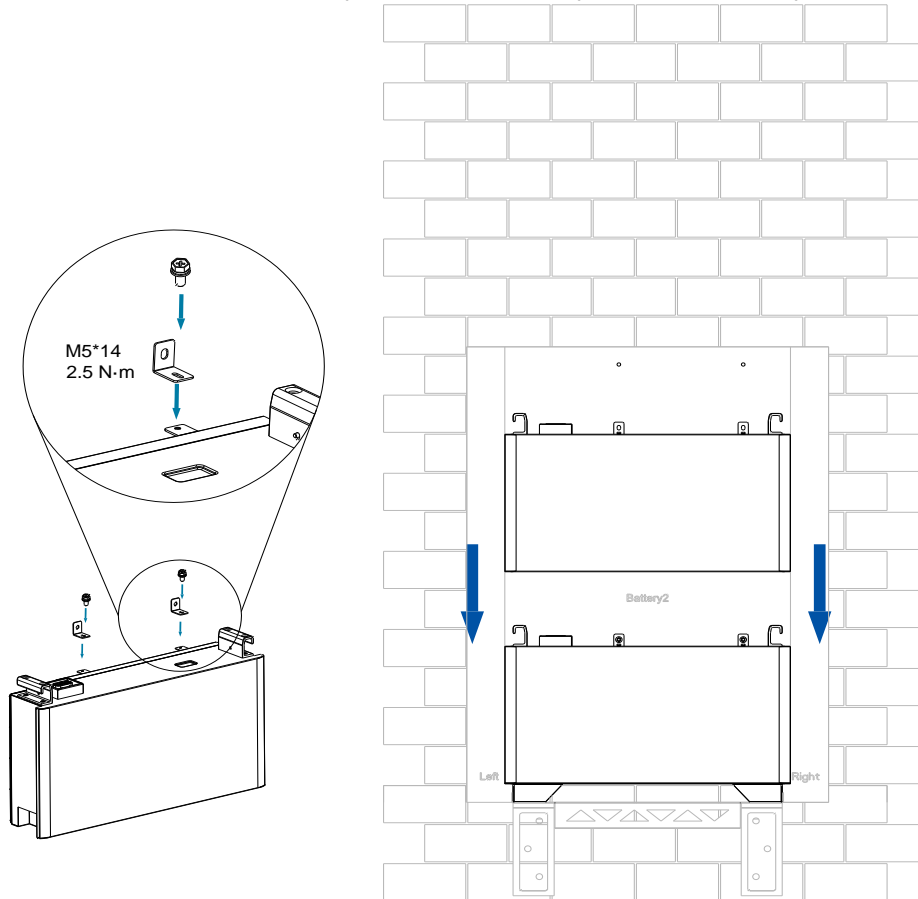

Figure 4.36. Installing the second battery without

- b. On the top of the battery pack, align the locking brackets to the drilled holes and install the gaskets and M6*50 screws to secure the battery pack to the wall.

On the left and right bottom sides of the battery pack, install M5*14 screws to secure two batteries.

Australia only: As shown in the right figure, install the metal grounding plate and secure it by installing two M4*12 screws.

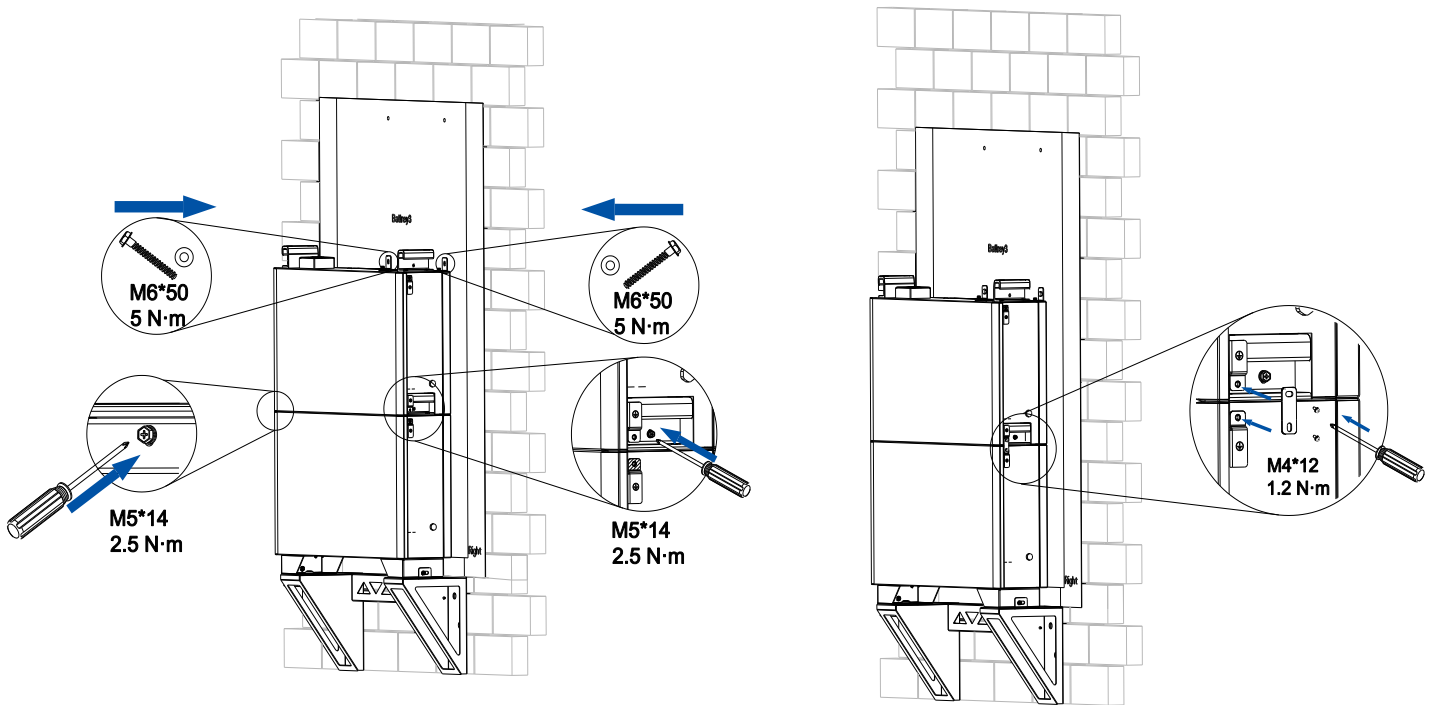

Figure 4.37. Securing the batteries

- c. (Optional) If needed, repeat steps a and b to install the third battery.

Australia only: Install the metal grounding plate and secure it by installing two M4*12 screws.

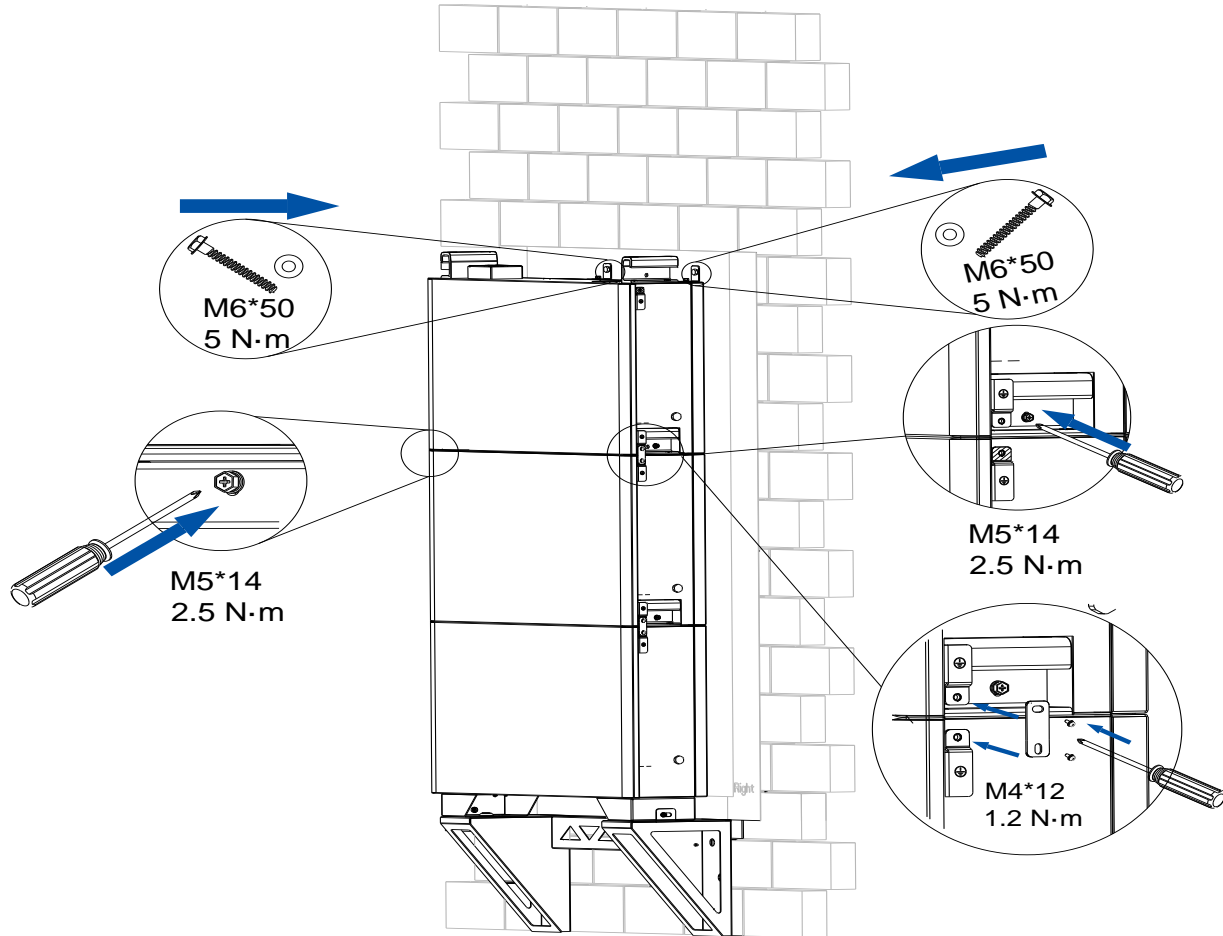

Figure 4.38. Installing the third battery

Step 3. (Optional) Install the charger (CU2-7.4K-S-I).

- a. Get the holster from the charger package. Install the holster onto the right side of the charger.
- b. Place the charger onto the battery. Push it downwards.
- c. On the left and right bottom sides of the battery pack, install M5*14 screws to secure the charger to the battery.

Australia only: Install the metal grounding plate and secure it by installing two M4*12 screws

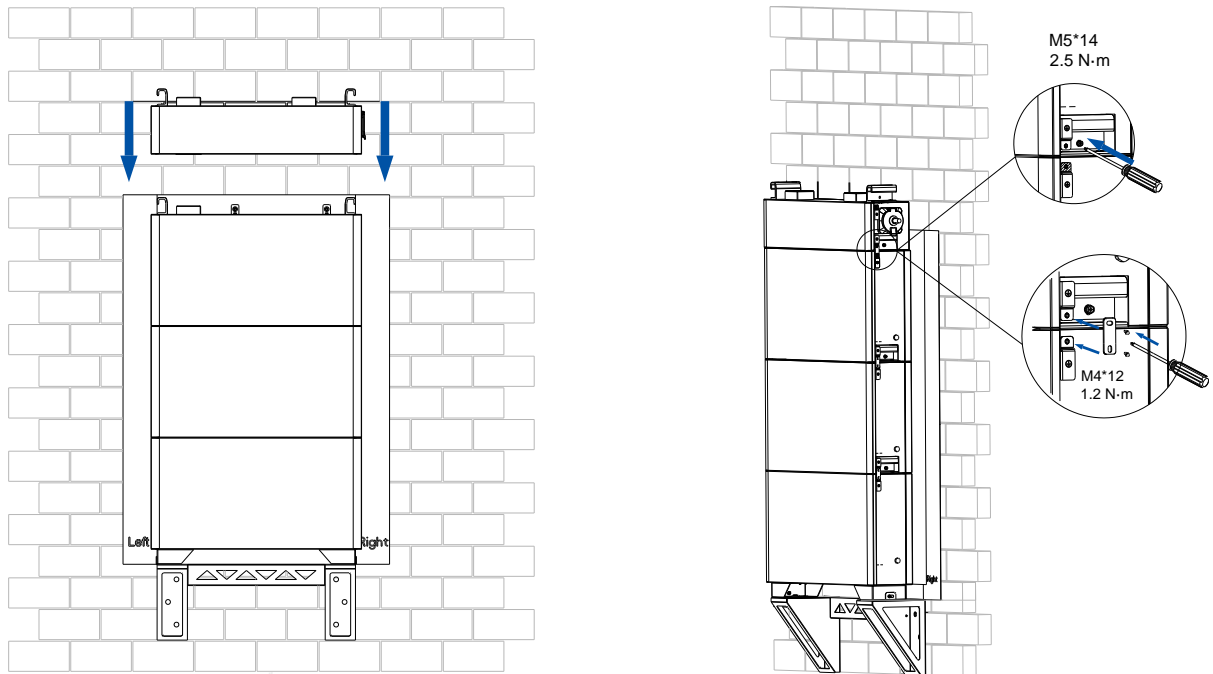

Figure 4.39. Installing the charger

- e. Install the holster on the wall by using three M4*32 screws.

Note: The holster is used to secure the charger cable. It is recommended that you purchase the cable from SAJ and connect the cable after all devices are installed.

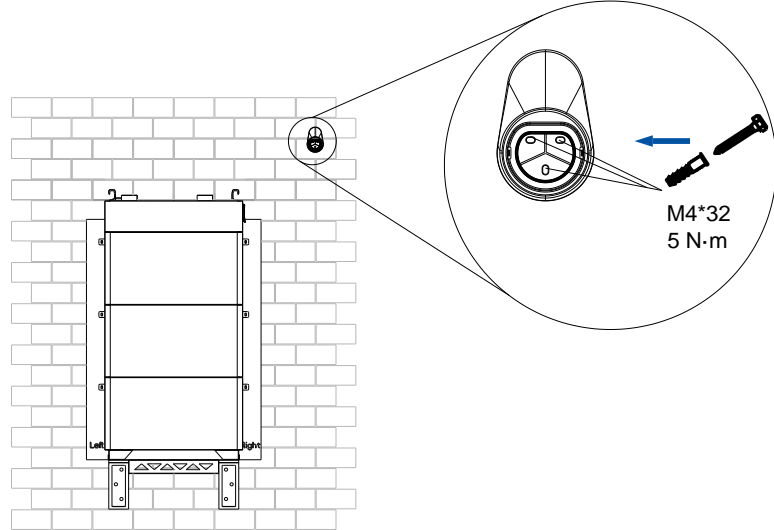

Figure 4.40. Installing the charger cable holster

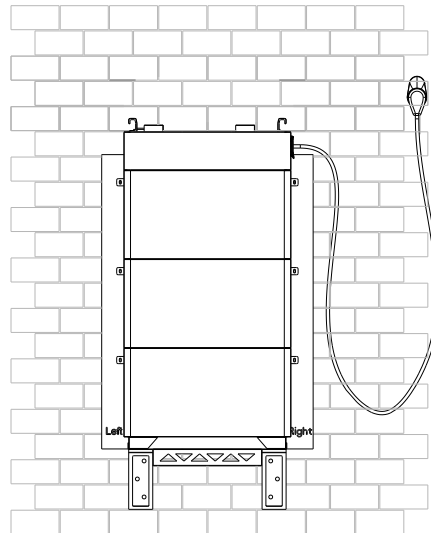

Figure 4.41. Connecting the charger cable

Step 4. Install the inverter (HS3-*xk*-S2-W-B, HS3-*xk*-S2-W-P, HS3-*xk*-S2-G-B, or HS3-*xk*-S2-G-P).

- a. Place the inverter onto the battery or charger (if available) and push it downwards.
- b. On the left and right bottom sides of the battery pack, install M5*14 screws to secure the inverter to the beneath device (battery or charger; here takes a charger as an example).

Australia only: Install the metal grounding plate and secure it by installing two M4*12 screws.

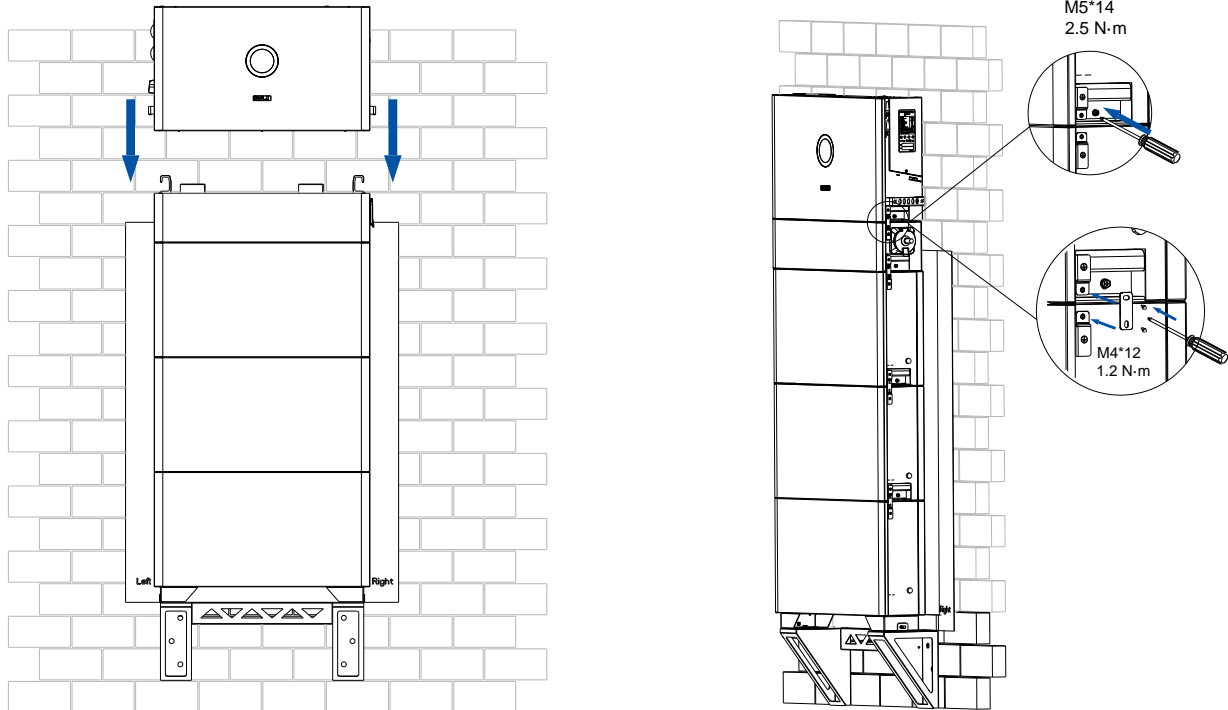

Figure 4.42. Installing the inverter

Installation completion view

Single stack: supporting 1 to 3 batteries

Example of 3 batteries:

Inverter + charger + batteries

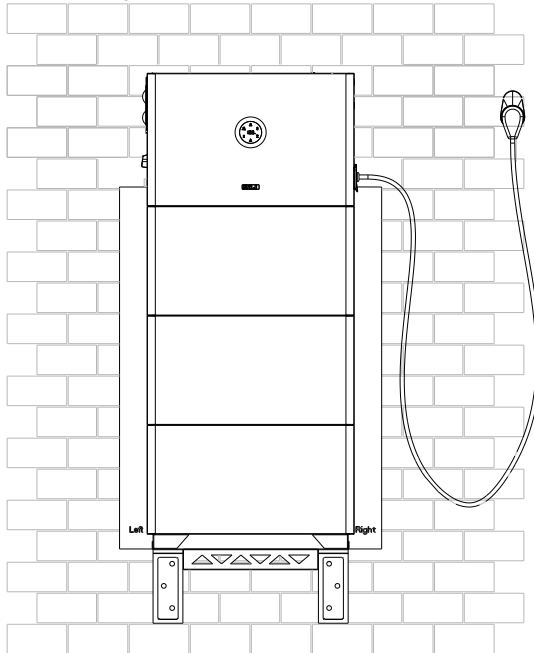

Inverter + batteries

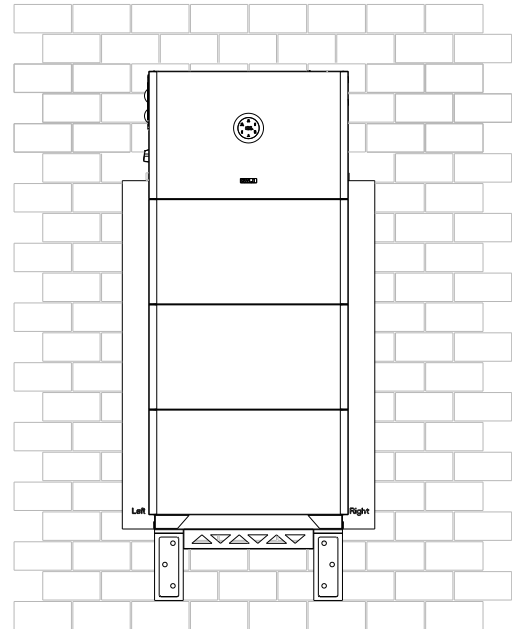

Figure 4.43. Completion view of a single stack

4.5.4. Installation of Multiple Battery Stacks (Optional)

About this task

One inverter supports up to eight batteries; however, for safety reason, a maximum of three batteries can be installed vertically in one stack. Therefore, extra batteries must be installed in other stack(s) and the extra battery stack must be installed with a battery combiner box (BC3-TV). Due to the cable length limitations, the distance between each battery stack is 0.5 meter.

It is recommended that the batteries be assembled in different stacks as follows:

Quantity of batteries supported by one inverter	Quantity of battery stacks	Quantity of batteries in each stack
1, 2, or 3 batteries	1	1
4 batteries	2	2, 2
5 batteries	2	3, 2
6 batteries	2	3, 3
7 batteries	2	3, 2, 2
8 batteries	3	3, 3, 2

The procedures in the ground-mounting manner and the wall-mounting manner are the same.

Procedure

Step 1. Place the junction box onto the battery. Push it downwards.

On a type A battery pack

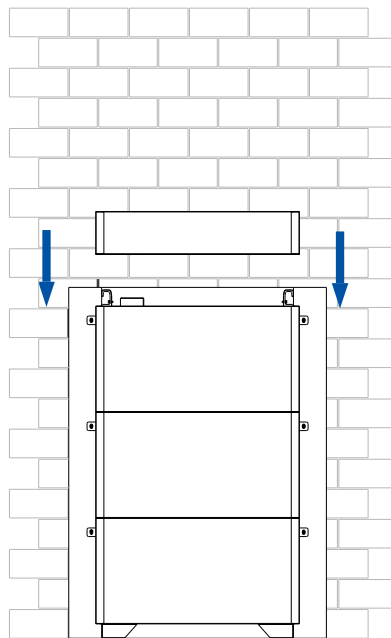

On a type B battery pack

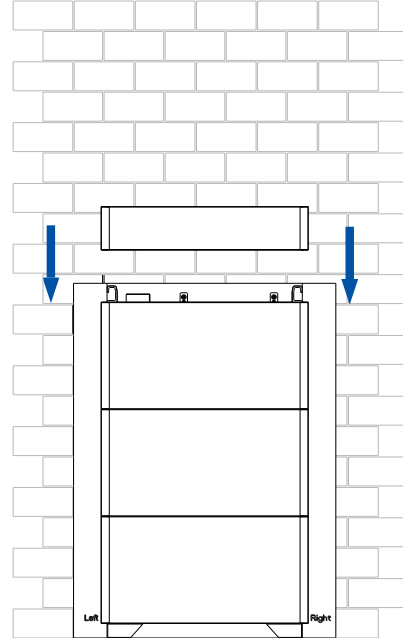

Figure 4.44. Installing a battery junction box

Step 2. Depending on the battery type, perform as follows:

- Type A battery pack: Install screws on both lower sides of the junction box to secure the junction box to the beneath battery.

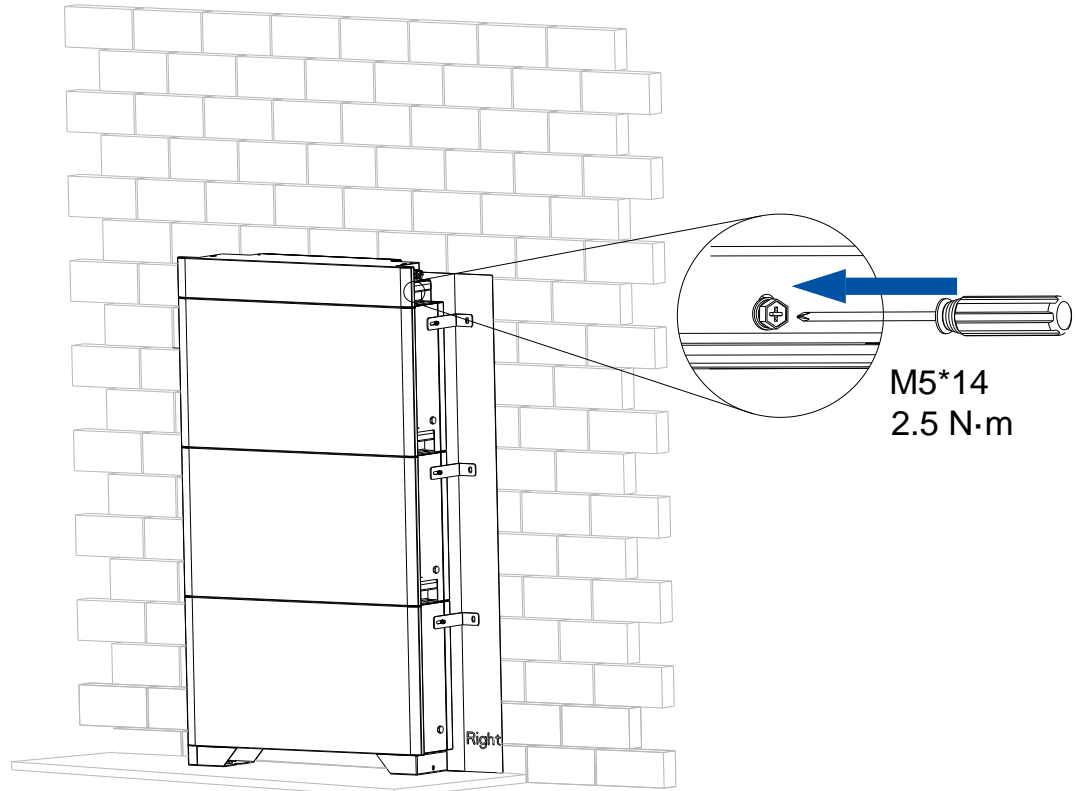
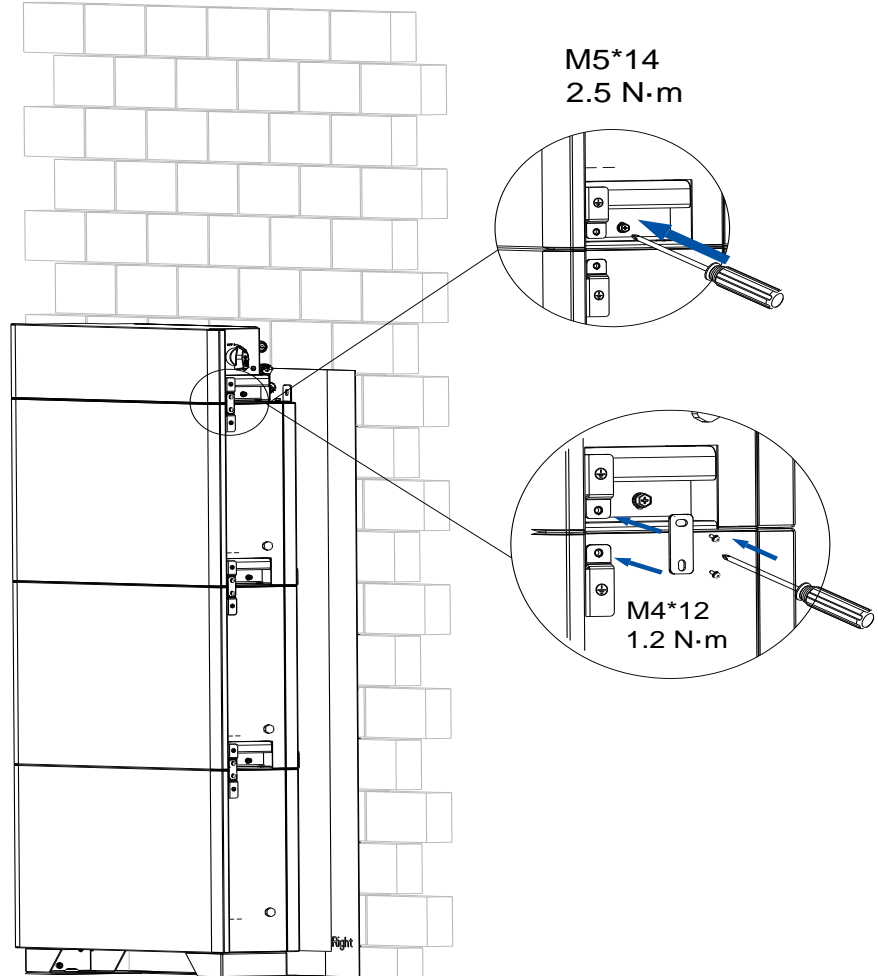

Figure 4.45. Installing a battery junction box

- Type B battery pack: Type B battery pack: Install screws on both lower sides of the junction box to secure the junction box to the beneath battery.

Australia only: Install the metal grounding plate and secure it by installing two M4*12 screws



Installation completion view

Multiple battery stacks: supporting four to eight batteries; distance between each stack is 0.5 meters.

Example of 8 batteries:

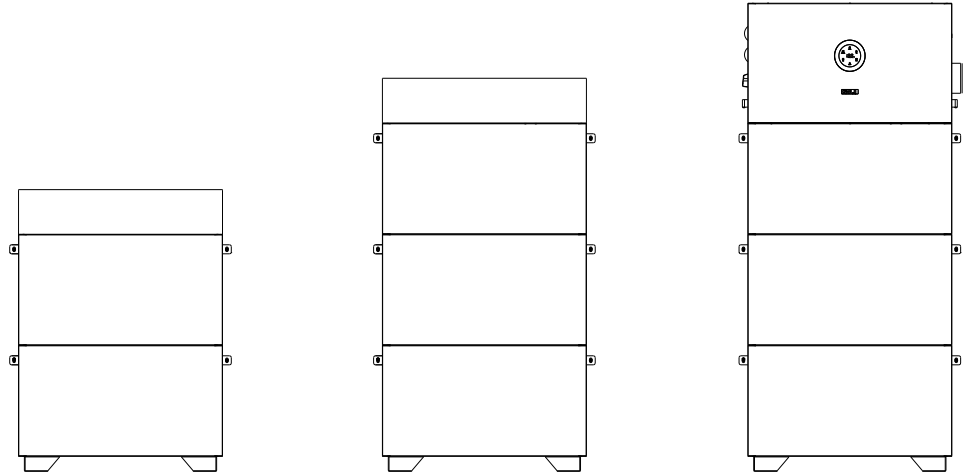

Figure 4.46. Completion view of three battery stacks

5.

ELECTRICAL CONNECTION



5.1. Safety Instructions

Electrical connection must only be operated on by professional technicians. Operators must be aware that the inverter is a bi-power supply equipment. Before connection, necessary protective equipment must be employed by technicians including insulating gloves, insulating shoes, and safety helmet.

DANGER

- Dangerous to life due to potential fire or electricity shock.
- Do not install the inverter near any inflammable or explosive items.
- Dangerous to life due to potential fire or electricity shock.
- When it is powered on, the equipment should in conformity with national rules and regulations.
- The direct connection between the inverter and high voltage power systems must be operated by qualified technicians in accordance with local and national power grid standards and regulations.
- The PV arrays will produce lethal high voltage when exposed to sunlight.

NOTICE

Any improper operation during cable connection can cause device damage or personal injury

5.2. Assembling the AC-side Connection

5.2.1. Opening the AC-side Cover

Loosen the screw that locks the cover. Then, lift the cover upwards.

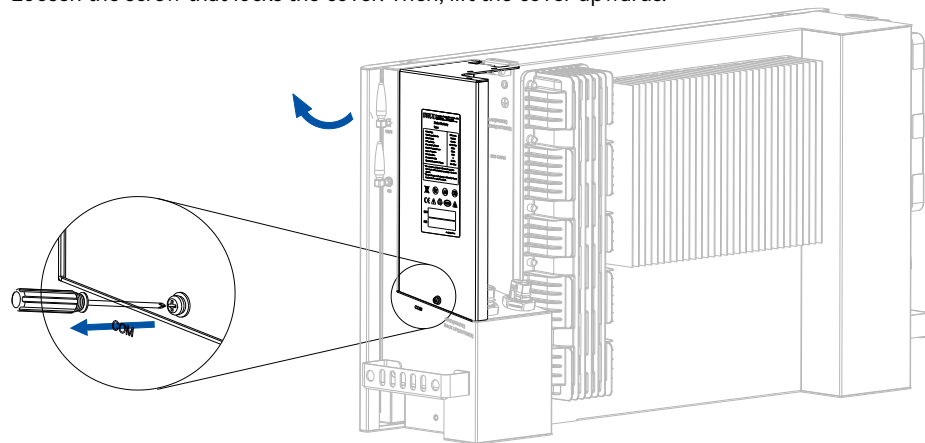

Figure 5.1. Opening the AC-side cover

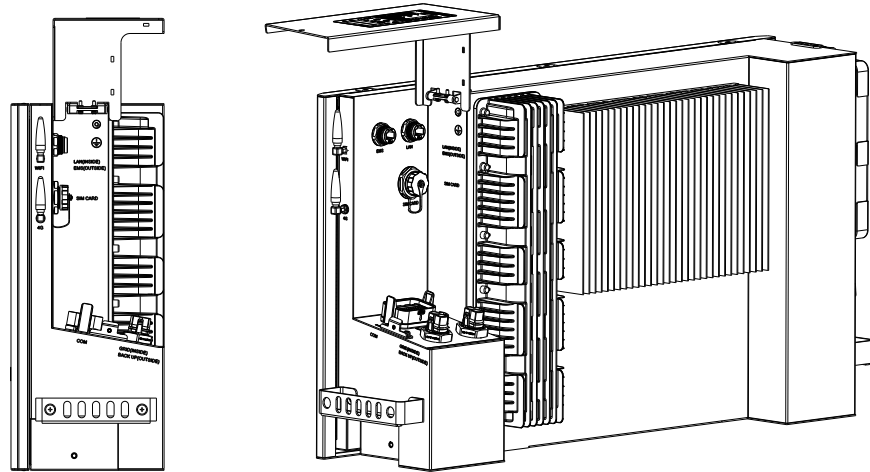

Figure 5.2. After the AC-side cover is opened

5.2.2. Connecting the Grounding Cable

About this task

This additional grounding cable must be connected before other electrical connection. You can connect the grounding cable to the grounding point on either AC-side or DC side. Here takes the grounding point on the AC-side as an example.

The cable needs to be prepared by the user. It is recommended that a 6-mm² conductor cross-sectional area of cable be used.

Procedure

Step 1. Assemble the cable and OT/DT terminal.

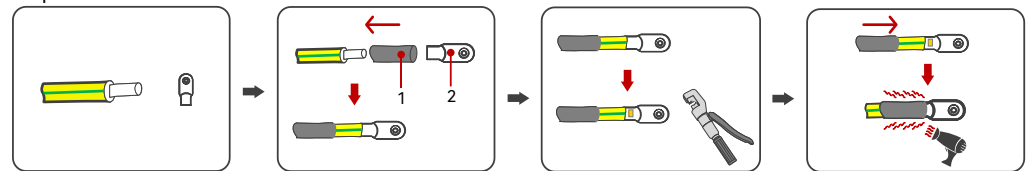

Figure 5.3. Preparing the grounding cable

1	Heat shrink tube	2	OT/DT terminal
---	------------------	---	----------------

Step 2. Remove the M4*10 screw from the grounding port. Connect and secure the grounding cable, as shown below:

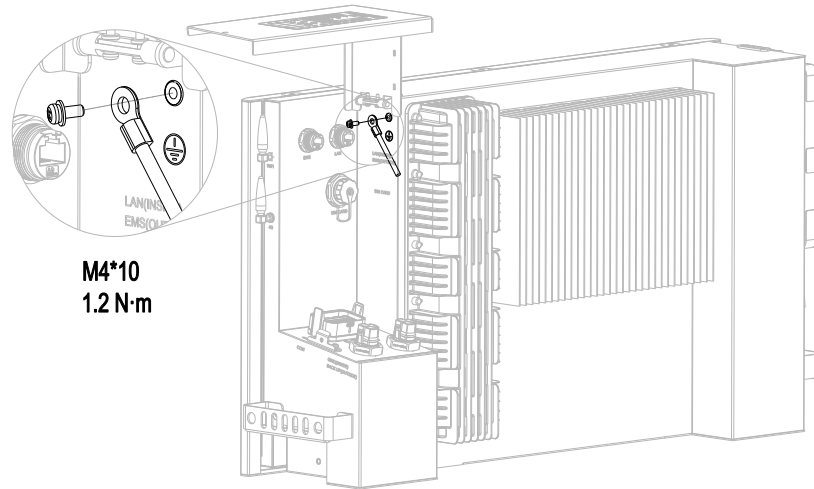

Figure 5.4. Connecting the additional grounding cable

5.2.3. (Optional) Installing the SIM Card

Only the 4G model provides the SIM card slot.

Loosen the cover of the SIM card slot. Then, insert the SIM card to the slot.

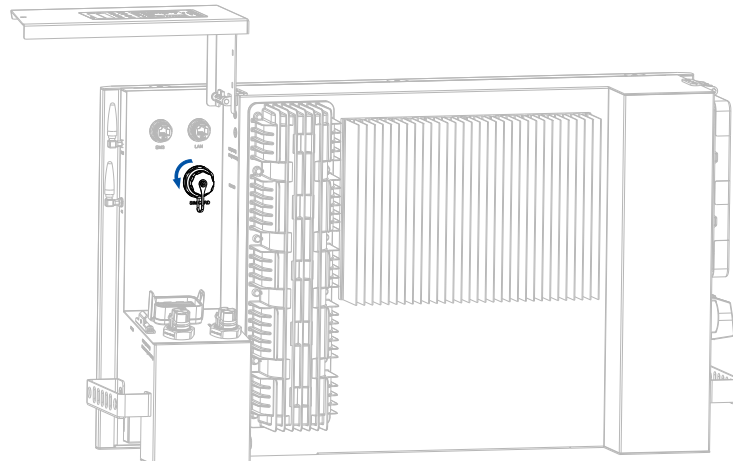

Figure 5.5. Loosening the cover on the SIM card slot

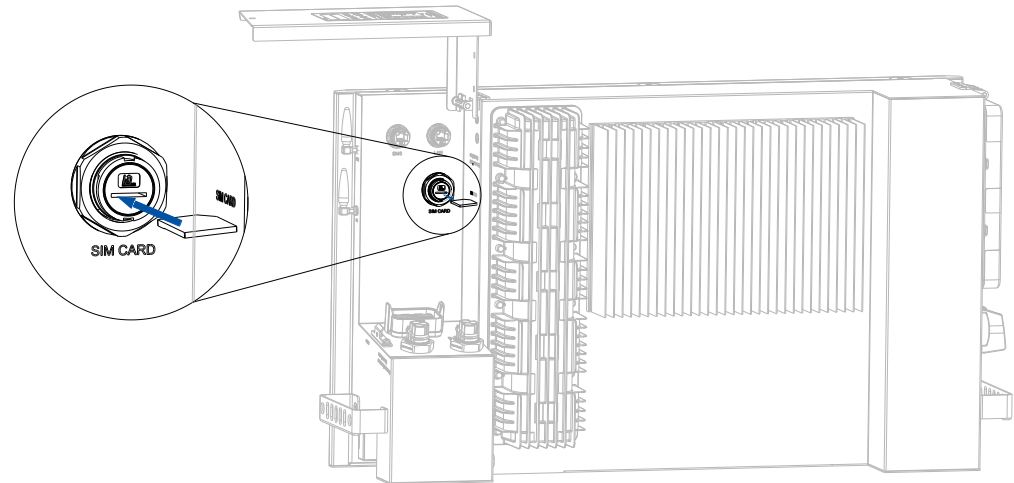

Figure 5.6. Inserting the SIM card

5.2.4. (Optional) Assembling the LAN Electrical Connection

About this task

Only the W (Wi-Fi) model provides the LAN port.

If you choose to use Wi-Fi connection manner or has an EMS connected in the ESS, no need to connect the LAN cable.

If you choose to use Ethernet connection manner, perform as follows:

Procedure

Step 1. Remove the RJ45 cable fastener from the LAN port.

Step 2. Use a standard RJ45 cable. Insert the cable through the cable fastener as shown below. Assemble the cable fastener.

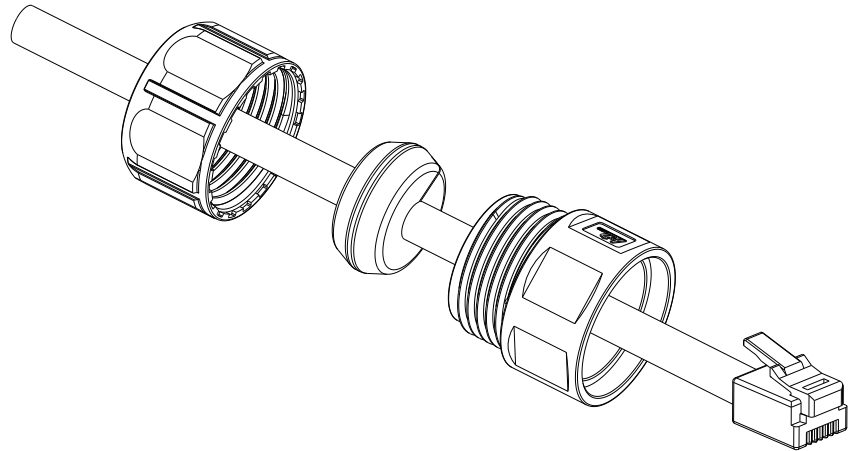

Figure 5.7. Preparing the LAN cable

Step 3. Connect the LAN cable from the LAN port on the inverter to the router.

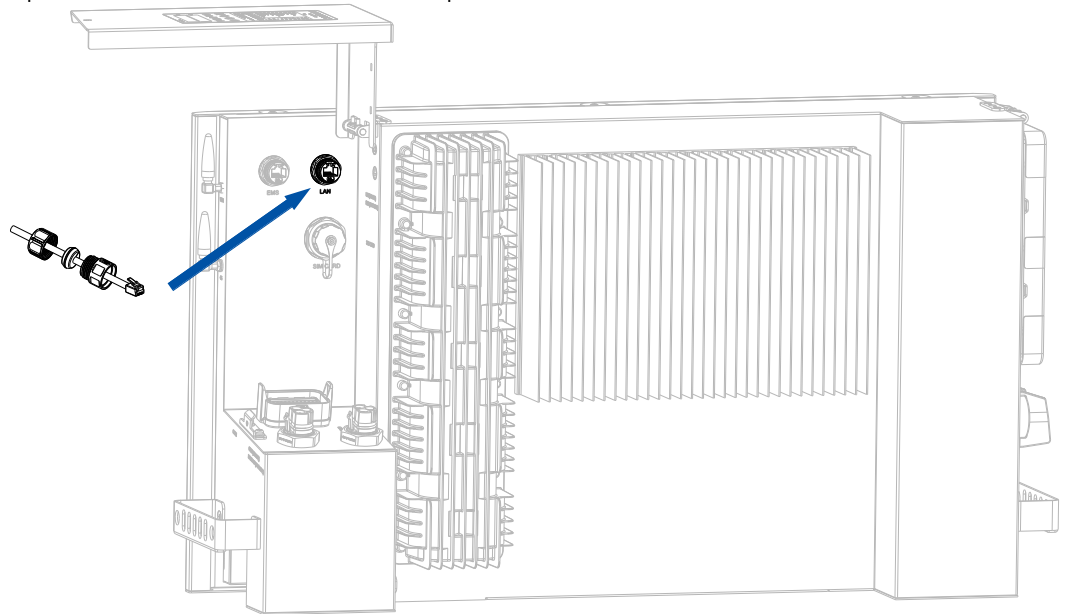

Figure 5.8. Connecting the LAN cable

5.2.5. Assembling the EMS Electrical Connection

To connect an EMS to the inverter, perform as follows:

Step 1. Remove the RJ45 cable fastener from the EMS port.

Step 2. Use a standard RJ45 cable. Insert the cable through the cable fastener as shown below. Assemble the cable fastener.

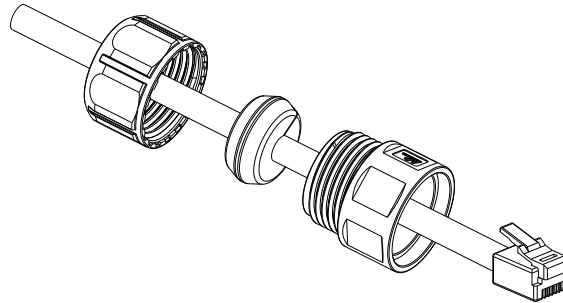

Figure 5.9. Preparing the EMS cable

Step 3. Connect the cable from the EMS port on the inverter to the LAN port on SAJ eManager (EMS).

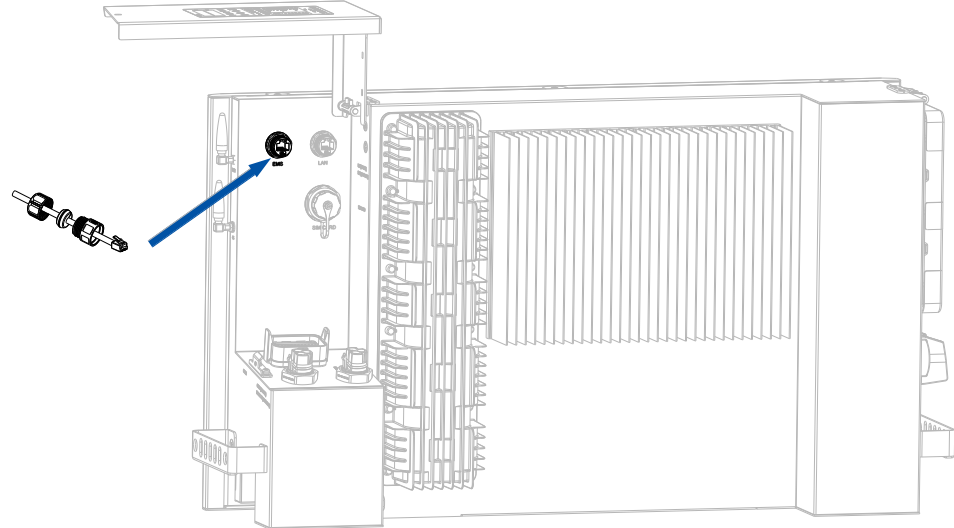

Figure 5.10. Connecting the EMS cable

5.2.6. Installing a Circuit Breaker

For safety operation and regulation compliance, install a 63 A or higher air circuit breaker between the grid and the inverter.

By installing a circuit breaker, the inverter can be disconnected from the grid quickly and safely when the leakage current detector embedded in the inverter detects that the leakage current exceeds the limitation.

Notice: In the parallelling scenario, do NOT connect multiple inverters to one AC circuit breaker.

5.2.7. Installing an RCD (optional)

Generally, an external residential current device (RCD) is not required since the inverter is integrated with a residential current monitoring unit (RCMU). However, if a CU2 charger is installed or the local regulations require so, a type A RCD with the action current 300 mA or higher needs to be installed.

5.2.8. Connecting the Smart Meter

To buy a smart meter, contact SAJ for more details.

By using a SAJ-recommended smart meter, many functions can be implemented, such as the export limitation function.

Connect the smart meter as shown in section 5.6 “System Connection Diagram”.

5.2.9. Connecting the Grid and Backup Loads

About this task

By default, the grid or backup load connector contains a one-hole rubber plug inside for connecting a three-wire cable. The following takes a three-wire cable as an example.

However, if you choose to use three separated cables for grid or backup load connection, to ensure sealing safety, use the three-hole rubber plug provided in the accessory bag, instead of the original one-hole rubber plug in the connector.

Before you start

Select cables according to the below specification.

Cable type	Conductor cross-sectional area of cables		Conductor material	Cable diameter (with insulation)
	Range	Recommended value		
One three-wire cable	10–13.3 mm ² or 7–6 AWG	10 mm ² or 6 AWG	Copper	Range: 13–17.5 mm
Three separated cables	/	10 mm ²		Range: 6.5–8.5 mm Double-layer insulation

Table 5.1 Recommended AC cable specification

Procedure

Step 1. Strip the insulation (13-mm length) off the wires.

Step 2. Connect the cable to the grid or backup load connector.

Note: In some earlier configurations, the waterproof gland nut (callout 4 in the following illustration) may not be provided.

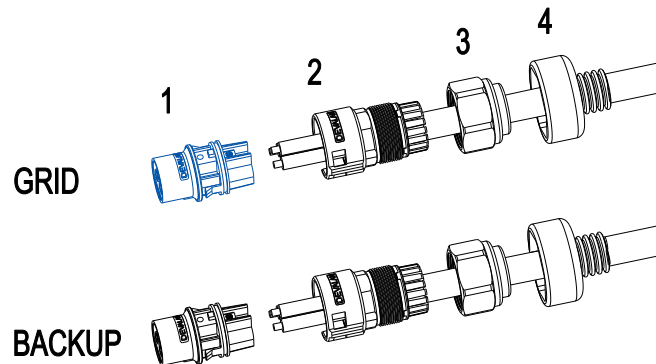
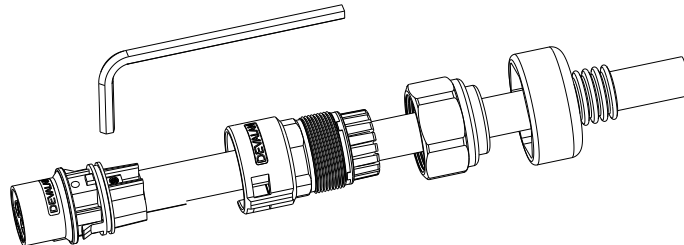

Figure 5.11. Preparing the cable

Step 3. Secure the cable to the connector. Then, assemble the connector.



- Step 4. Use a flathead screwdriver to remove the dustproof covers from the GRID and BACK-UP ports. Then, connect the cables to the GRID and BACKUP ports on the inverter.

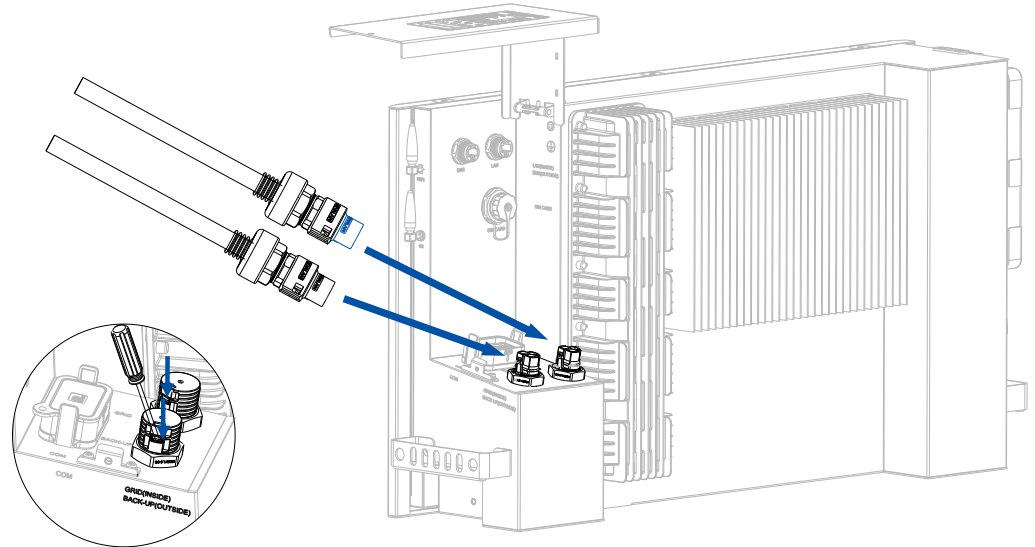

Figure 5.12. Connecting the grid and backup load cables

5.2.10. Assembling the Communication Connection

- Step 1. Disassemble the communication cable connector.
- Press the tabs on two sides of the connector and pull the connection terminal block outwards.
 - Rotate the nut anti-clockwise and remove it from the connector body.
 - Remove the rubber plugs out of the seals.

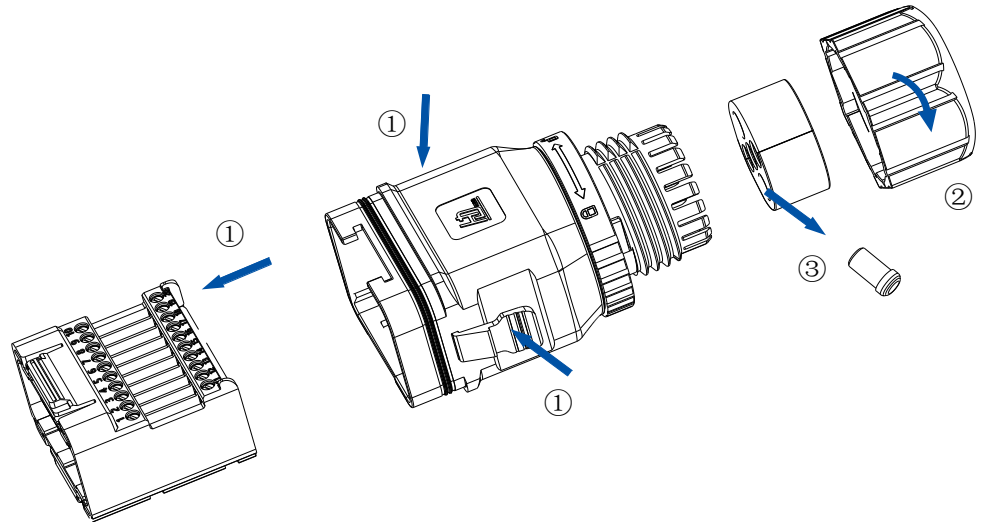
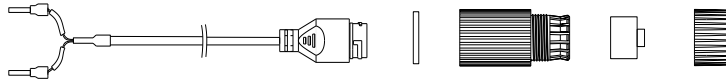

Figure 5.13. Disassembling the 24-pin communication cable connector

Step 2. Prepare cables.

- Meter communication: Use the provided communication cable kit. It contains a communication cable with an RJ45 port and two assembled terminals and cable fastener parts.



- Other terminal connection: Per you needs, prepare cables. Strip the insulation around 7.5 mm on cable ends and if needed, use provided insulated crimp terminals on the cable ends.

Suggested cable specifications:

- DO: 0.5-0.75 mm²
- Others: 0.2-0.5 mm²

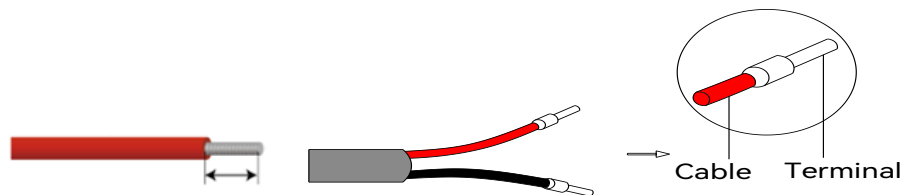

Figure 5.14. Installing the insulated crimp terminals on the cable ends

Step 3. Insert all communication cables through the nut, seals, and body of the connector.

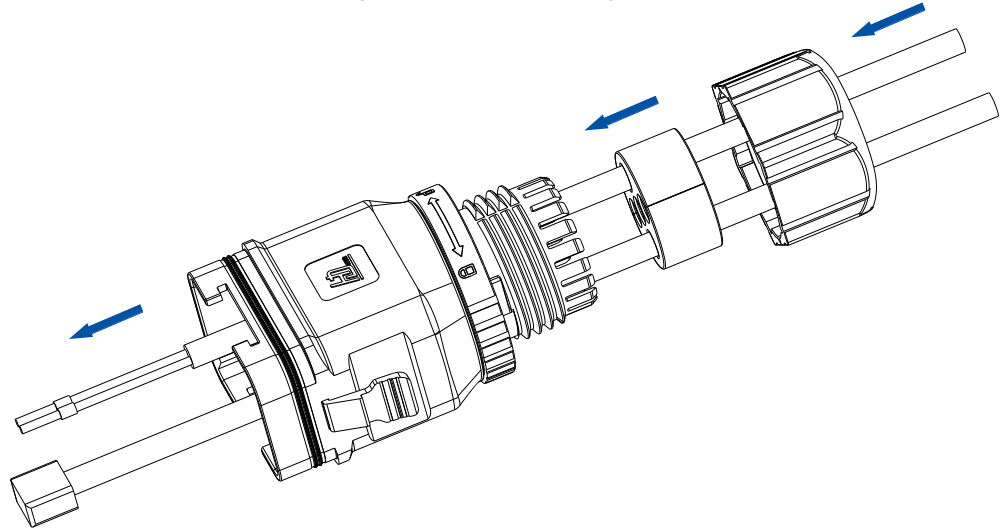

Figure 5.15. Inserting the cables through the connector

Step 4. Locate the ports and terminals on the connection terminal block according to their silkscreens. Connect all communication cables to the communication cable connector.

Name	Number	Pin definition	Description
PORT (RJ45 port)	/	1: CAN-H (with a 120 Ω resistor)	For paralleling connection scenario
		2: CAN-L	
		3: GND_W	
		4: SYN	
		5: GND_W	
		6: HOST	
		7: GND_W	
		8: TRF	
DRMs (RJ45 port)	/	1: DRM1/5	For RCR
		2: DRM2/6	For RCR
		3: DRM3/7	For RCR
		4: DRM4/8	For RCR
		5: REF D/0	/
		6: COM D/0	/
		7: NC	/

		8: NC	/
Terminals	4	DO1+	Dry output 1
	5	DO1-	Dry output 1
	6	DO2+	Dry output 2
	7	DO2-	Dry output 2
	11	RS485-A (with a 120 Ω resistor)	For external RS485 communication
	12	RS485-B	
	13	MET-A (with a 120 Ω resistor)	For meter communication
	14	MET-B	
	15	DI1+	Dry input 1
	16	DI1-	Dry input 1
	17	DI2+	Dry input 2
	18	DI2-	Dry input 2
	19	CAN_H (with a 120 Ω resistor)	For external CAN communication
	20	CAN_L	

Table 5.1. Ports and terminals on the connection terminal block

Step 5. Connect and secure the cables to the connection terminal block. Then, assemble the communication cable connector.

- a. Connect cables to corresponding terminals and RJ45 ports based on your needs.
- b. Use a screwdriver to secure the cables connected to the terminals.

Note: If any terminal that has been equipped with a 120 Ω resistor, such as METER-A, needs to be connected by a cable with the length longer than 20 meters, switch the resistor to ON status.

- c. Insert the connection terminal block back to the connector body until you hear a click sound.
- d. Insert the seals and nut back to the connector body.
- e. Rotate the nut clockwise until it is secured to the connector body.

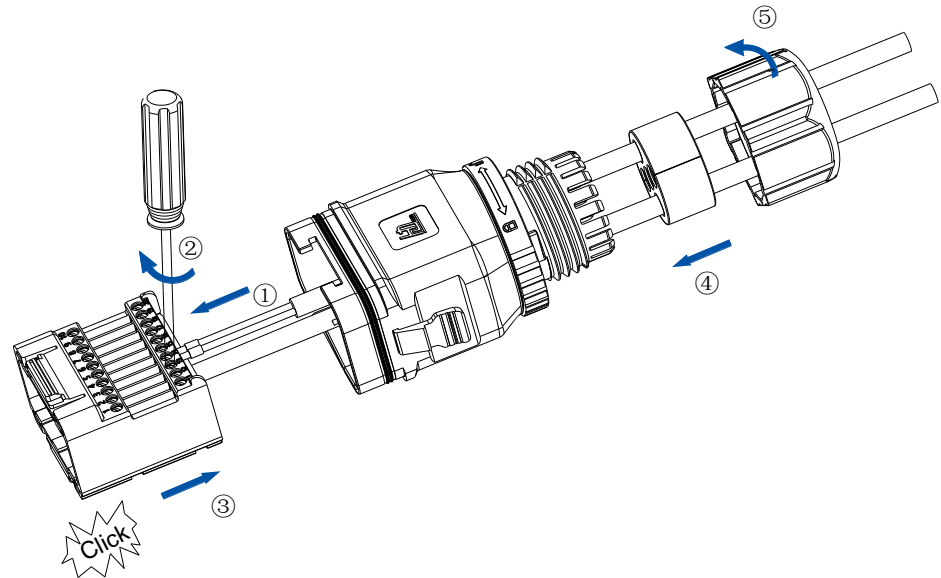

Figure 5.16. Assembling the connector

Step 6. 、 Connect the assembled communication terminal connector to the COMM port on the inverter.

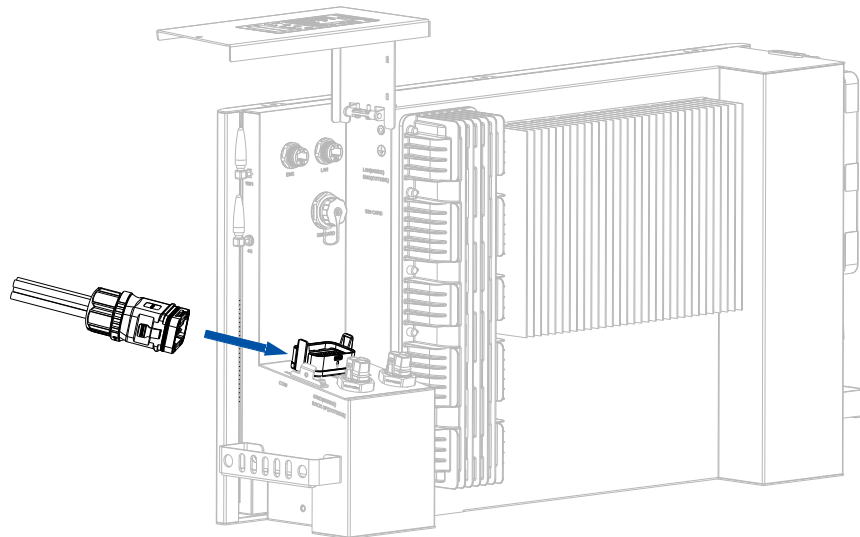

Figure 5.17. Connecting the connector to the inverter

Step 7. Connect the other end of the cables to external devices, such as the meter.

Note: For meter connection, use the communication cable (A) provided in the meter kit package. Connect the RJ45 connector on one end to the RJ45 port of the meter communication cable (B) that you have just connected to MET_A and MET_B on the communication terminal connector. Connect the two crimped cable ends on the other end to ports 24 and 25 on the meter. For detailed meter connection, refer to section 5.6 “System Connection Diagram”.

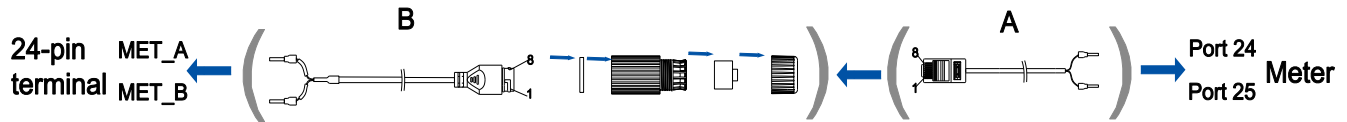

Figure 5.18. Assembling the meter connection

Callout	Description	RJ45 pin definition
A	Communication cable with an RJ45 connector	<ul style="list-style-type: none"> ● Pin 1: A1 ● Pin 2: B1 ● Pins 3 to 8: NC
B	Communication cable kit	<ul style="list-style-type: none"> ● Pin 1: For MET-A ● Pin 2: For MET-B ● Pins 3 to 8: NC

Table 5.2. Cables and parts used in the meter connection

5.2.11. Closing the AC-side Cover

Push the cover downwards. Use a screwdriver to tighten the screw to lock the cover securely.

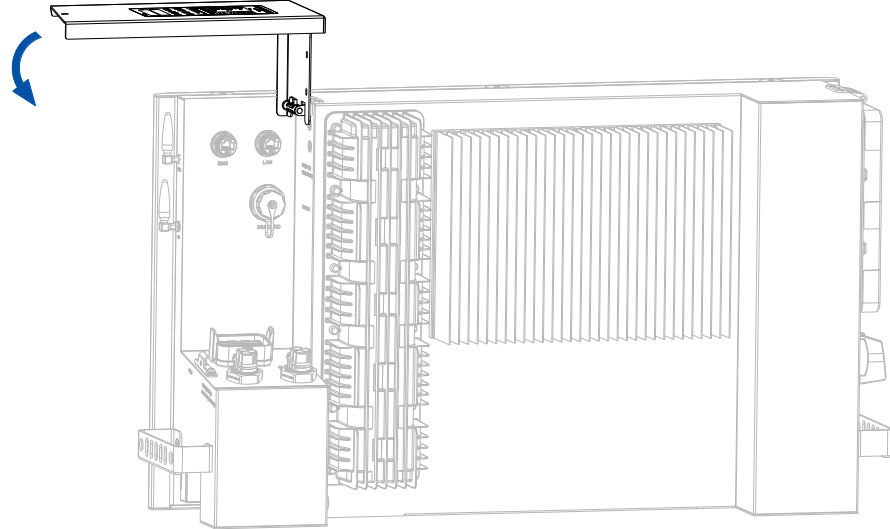

Figure 5.19. Closing the AC-side cover

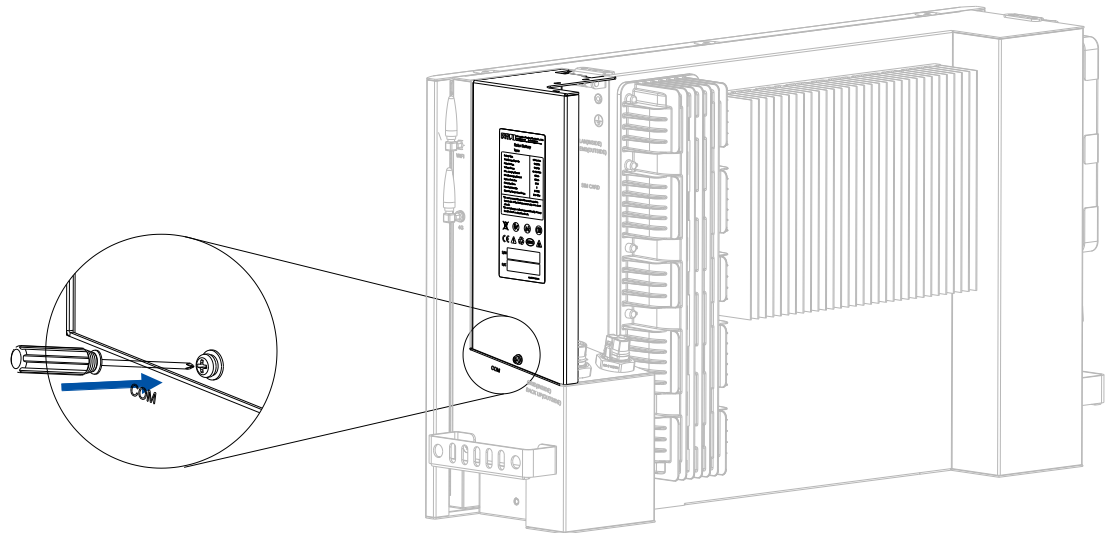

Figure 5.20. Securing the screw

5.3. Assembling the DC-side Connection

5.3.1. Opening the DC-side Cover

Loosen the screw that locks the cover. Then, lift the cover upwards.

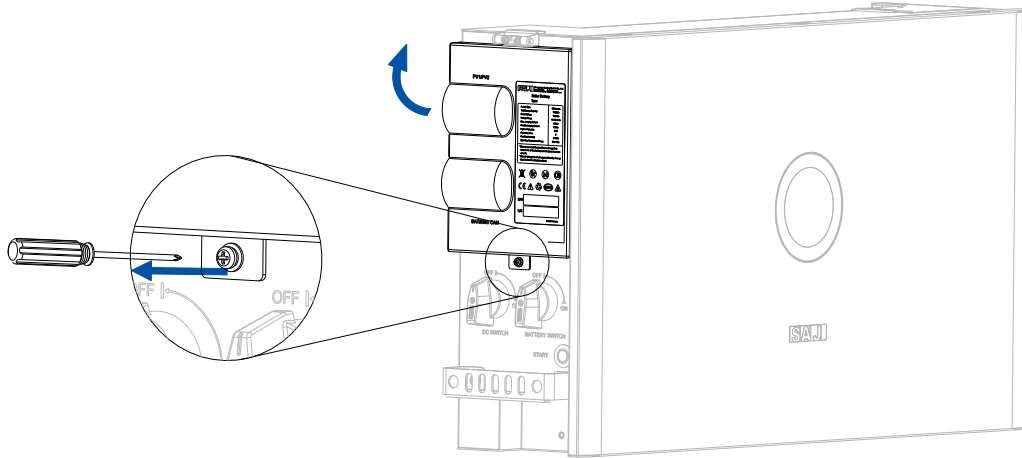

Figure 5.21. Opening the DC-side cover

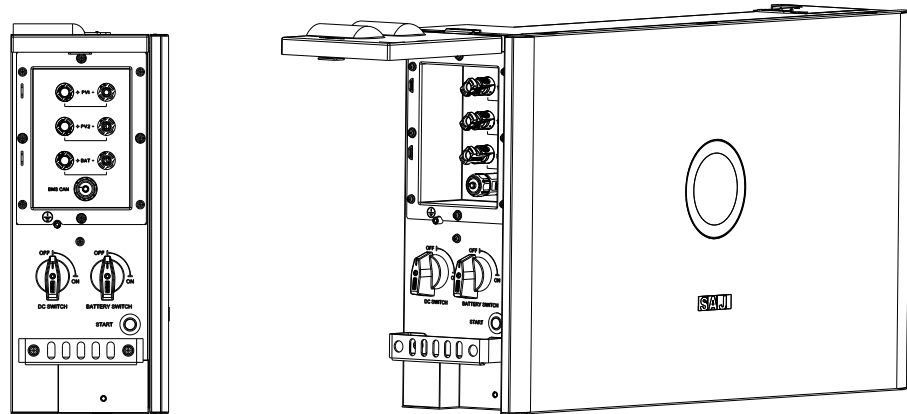



Figure 5.22. After the DC-side cover is opened

5.3.2. Connecting the PV Cables

About this task

- Read the safety instructions first before operations.

 WARNING
<ul style="list-style-type: none"> · Dangerous to life due to electric shock when live components or DC cables are touched. · The PV panel string will produce lethal high voltage when exposed to sunlight. Touching live DC cables results in death or lethal injuries. · DO NOT touch non-insulated parts or cables. · Disconnect the inverter from voltage sources. · DO NOT disconnect DC connectors under load. · Wear suitable personal protective equipment for all work.

- The inverter cannot be used with functionally earthed PV arrays.

Prerequisite

- Verify that the PV array is properly insulated to ground before it is connected to the inverter.
- Select cables according to the below specification.

Conductor cross-sectional area of cables (mm ²)		Conductor material
Scope	Recommended value	Outdoor copper wire cable, complying with 600 V DC
5.0-6.0	6.0	

Table 5.3. Recommended specifications of DC cable

- Verify that one end of the positive cable and one end of the negative cable are properly connected to the positive and negative sides of the solar panels.
- Use the positive and negative PV connectors provided in the accessory bag.

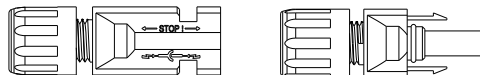

Figure 5.23. Positive and negative PV connectors

- Verify that the DC switch on the inverter is in OFF position to avoid short circuit caused by maloperations.

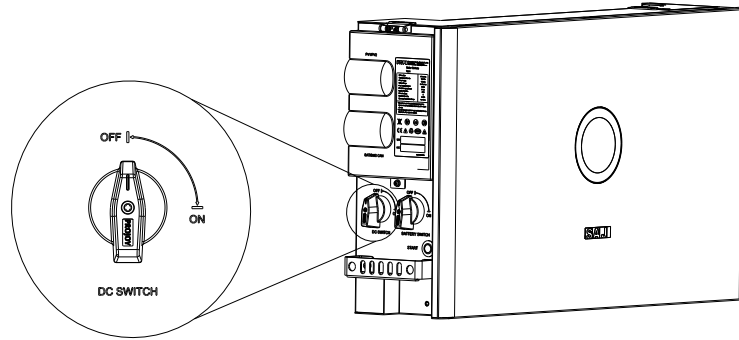

Figure 5.24. DC switch in OFF position

(For Australia) To comply with local regulations and for further safety consideration, use a reliable tool (such as a lock with a key) to lock the switch, so that others cannot unlock it easily.

Procedure

Step 1. Use a 3-mm wide-bladed screwdriver to strip the insulation layer around 8 to 10 mm length from one end of each cable.

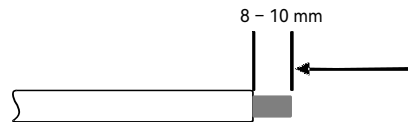

Figure 5.25. Stripping the insulation

Step 2. Insert the cable ends to the sleeves. Use a crimping plier to assembly the cable ends.

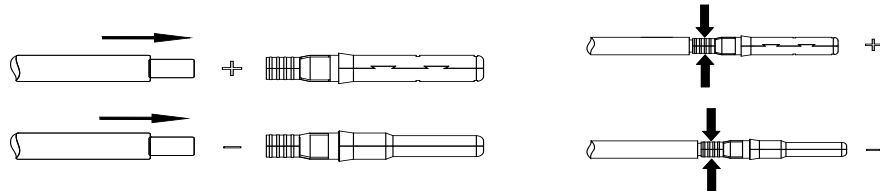

Figure 5.26. Assembling the cable ends

Step 3. Insert the assembled cable ends into the blue positive and negative connectors. Gently pull the cables backwards to ensure firm connection.

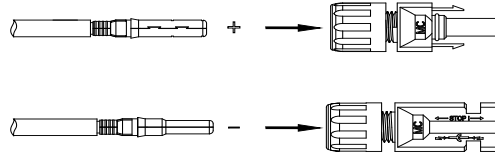

Figure 5.27. Assembling the positive and negative cables

Step 4. Tighten the lock screws on the positive and negative cable connectors.

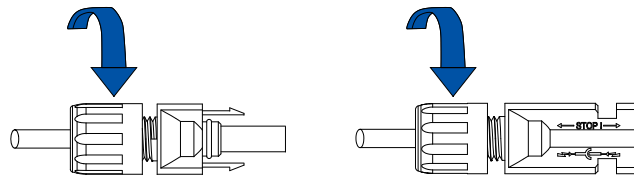
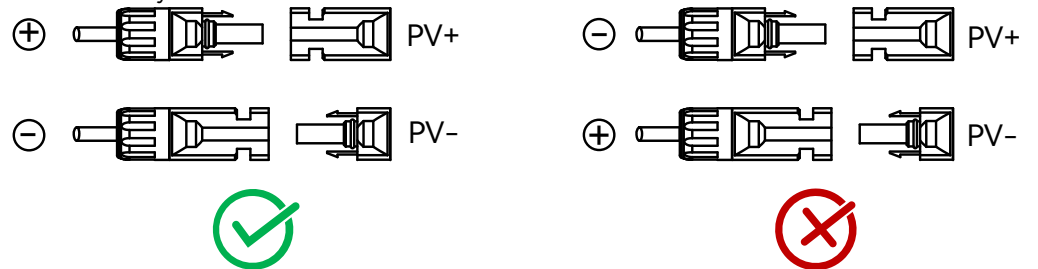

Figure 5.28. Securing the positive and negative cables

Step 5. Insert the positive and negative cable connectors into the positive and negative PV ports on the inverter until you hear a “click” sound to ensure firm connection.



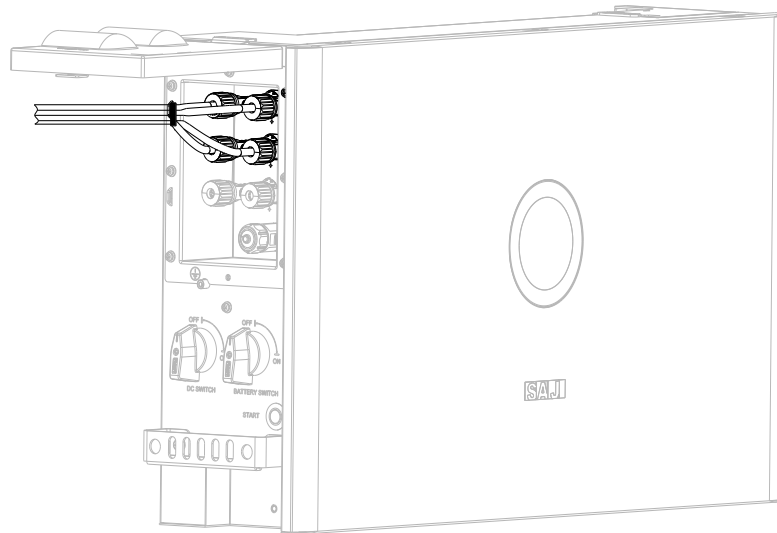

Figure 5.29. Connecting the PV cables

5.3.3. (Optional) Connecting Cables between Multiple Battery Stacks

About this task

This task is only applicable to the scenario in which four to eight batteries are connected to one inverter. On top of the first stack, an inverter is installed; while in the top of other stacks, a battery junction box has been installed on top of the stack. For details, refer to 4.5.4 "Installation of Multiple Battery Stacks (Optional)".

Pin definitions of the BMS CAN port are as follows:

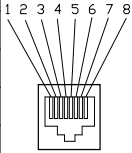
BMS CAN		
1	NC	
2	NC	
3	NC	
4	CANH	
5	CANL	
6	NC	
7	NC	
8	NC	

Procedure

Step 1. Prepare and connect the grounding cable to the battery junction box.

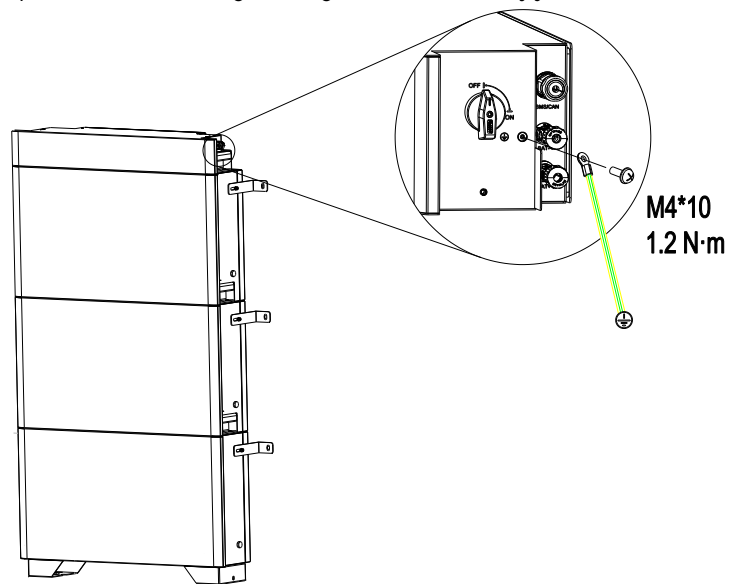

Step 2. Use the provided positive and negative power cables and the communication cable. Connect the cables from the junction box to the inverter, as listed below:

Cable	From the junction box	To the inverter
Positive and negative power cables	BAT+ and BAT- ports	BAT+ and BAT- ports
Communication cable	BMS/CAN port	BMS CAN port

Table 5.4. Cable connection between multiple stacks

Notes:

- The BMS CAN port on the inverter has been installed with an RJ45 connector plug. In this case, remove this plug and insert it into the BMS CAN port on the battery junction box on the left stack.
- The provided cables have been assembled with connectors. In some special cases, if you need to use your own cables, contact SAJ for technical support.

Taking eight batteries connecting to one inverter as an example:

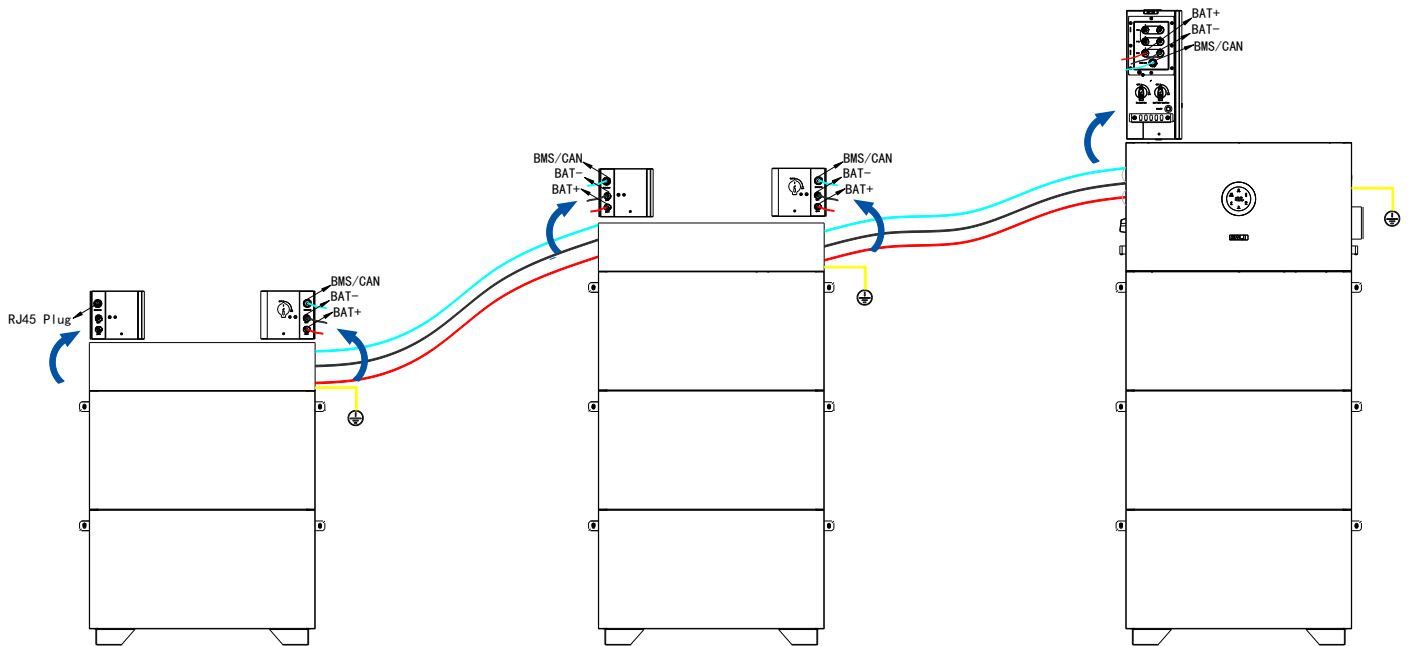

Figure 5.30. Connection of eight batteries in three stacks

5.3.4. Closing the DC-side Cover

Push the cover downwards. Use a screwdriver to tighten the screw to lock the cover securely.

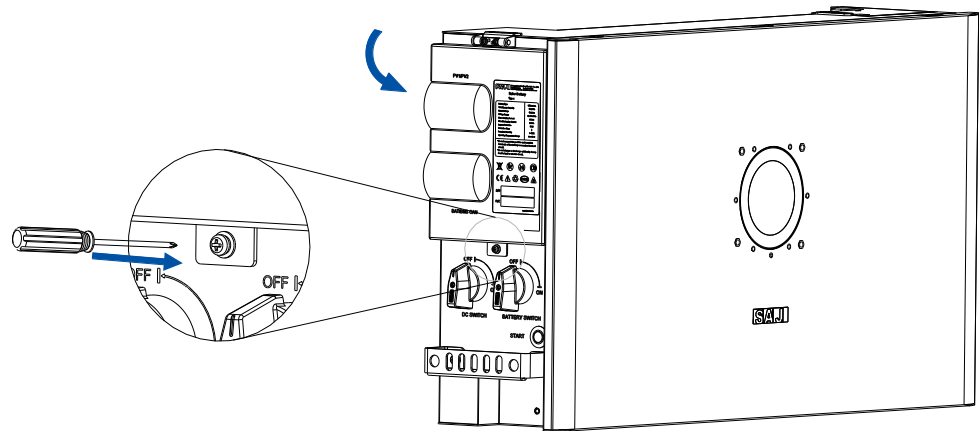

Figure 5.31. Closing the DC-side cover

5.4. Earth Fault Alarm

This inverter complies with IEC 62109-2 clause 13.9 for earth fault alarm monitoring. If an earth fault alarm occurs, the ring light on the inverter LED panel will be lit up in red and an error code <31> can be viewed on the Elekeeper App.

Note: The inverter cannot be used with functionally earthed PV arrays.

5.5. System Connection

For Australia and New Zealand, the system connection is as below:

Notes:

- For safety, the neutral cable of AC (grid) and backup side must be connected together.
- DO NOT connect the PE terminal of the BACKUP side.
- The E-BAR and the N-BAR must be short-circuited.

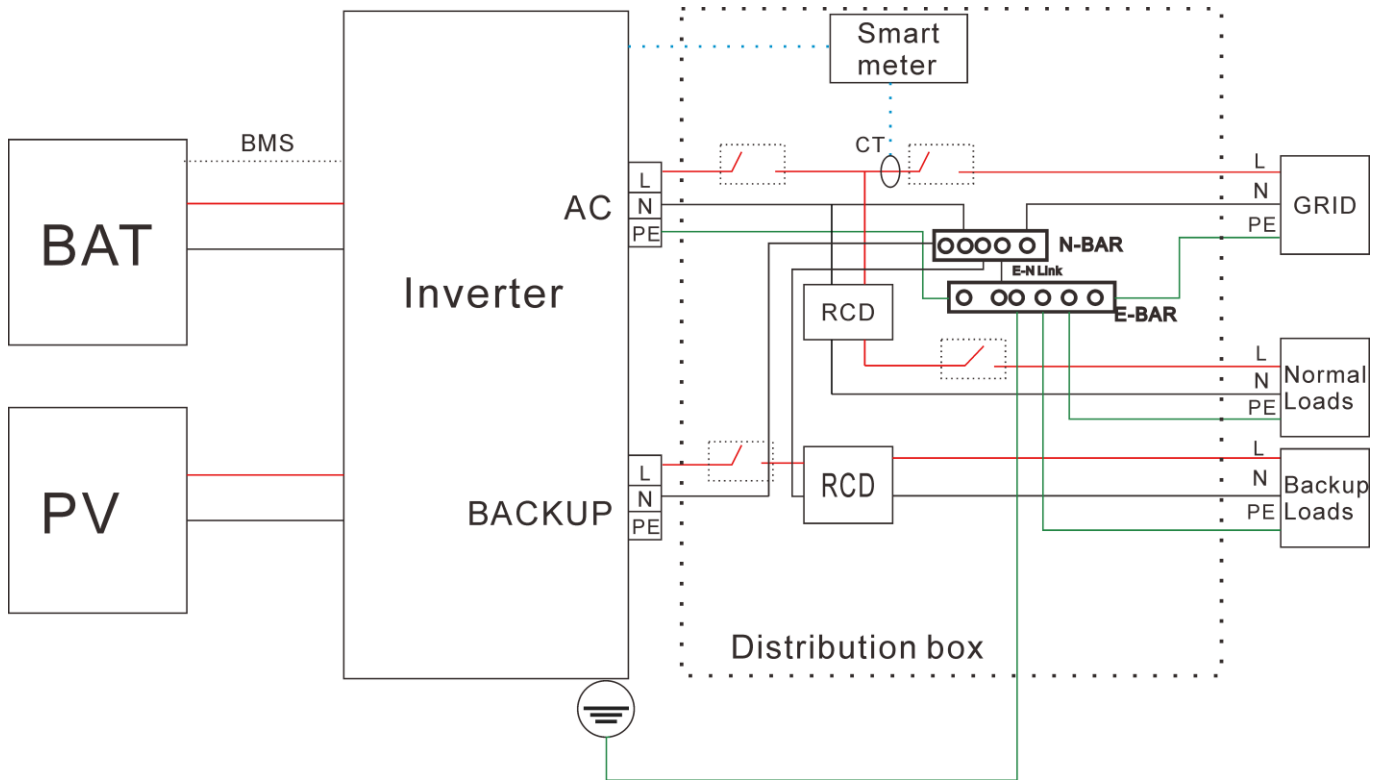

Figure 5.32. System connection in Australia and New Zealand

The system connection for the grid system without special requirements is as below:

Note: The backup PE line and earthing bar must be grounded properly. Otherwise, the backup function may be inactive during blackout.

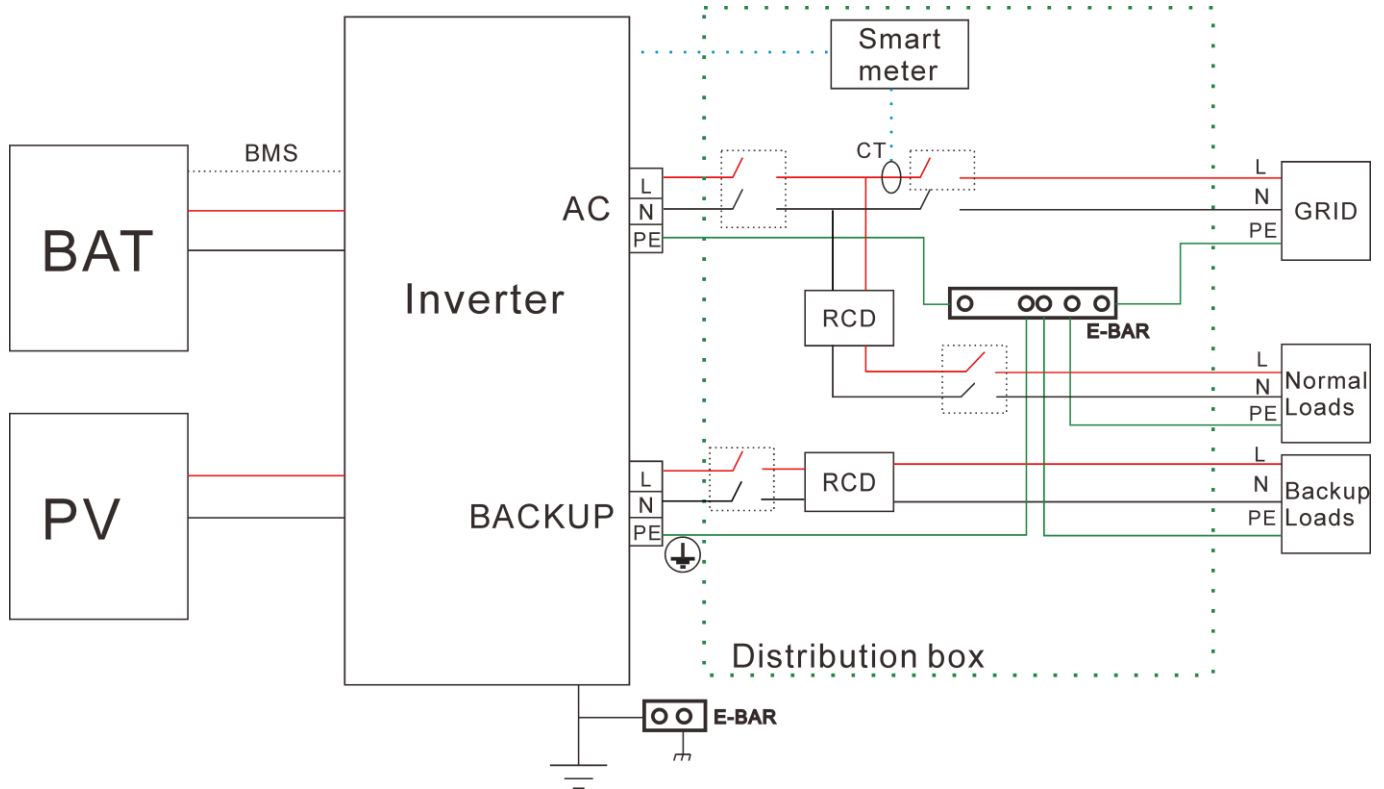
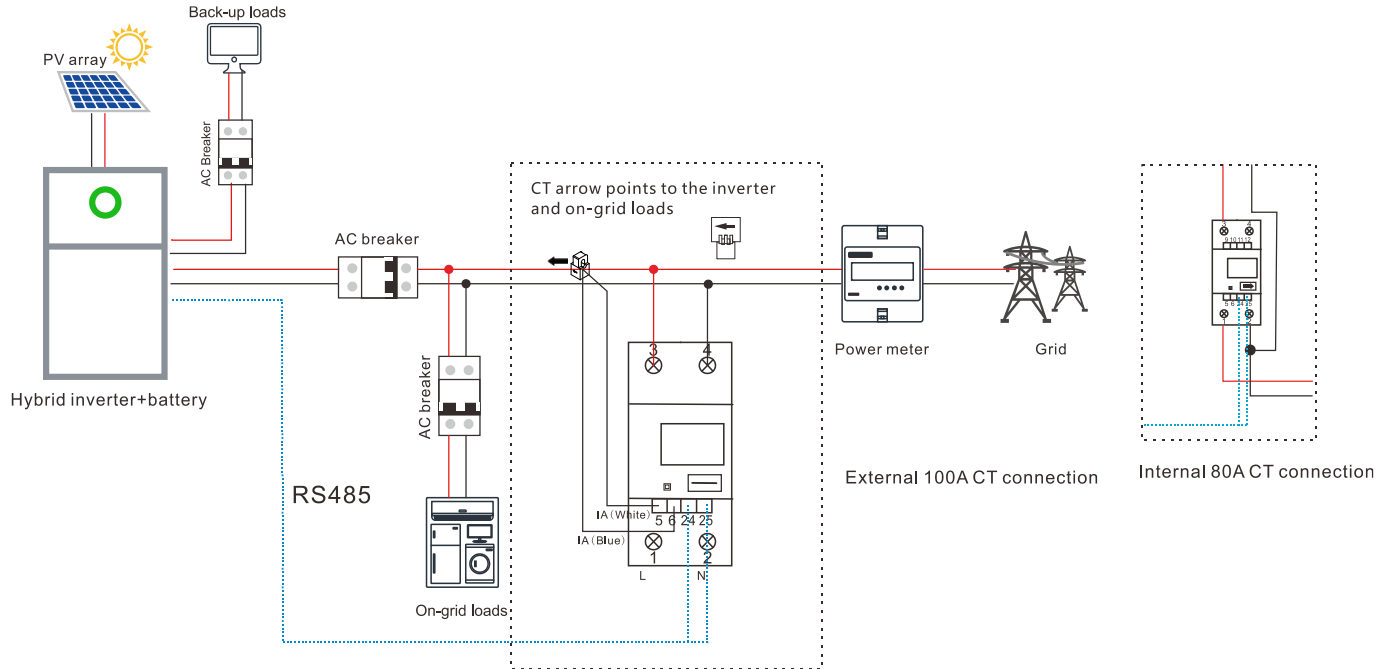

Figure 5.33. System connection in other countries and regions

5.6. System Connection Diagram

If the length of the RS485 cable between the inverter and the meter exceeds 20 meters, connect a 120Ω resistor to ports 24 and 25 on the meter.

- One HS3 in the single-phase grid



- One HS3 in the three-phase grid

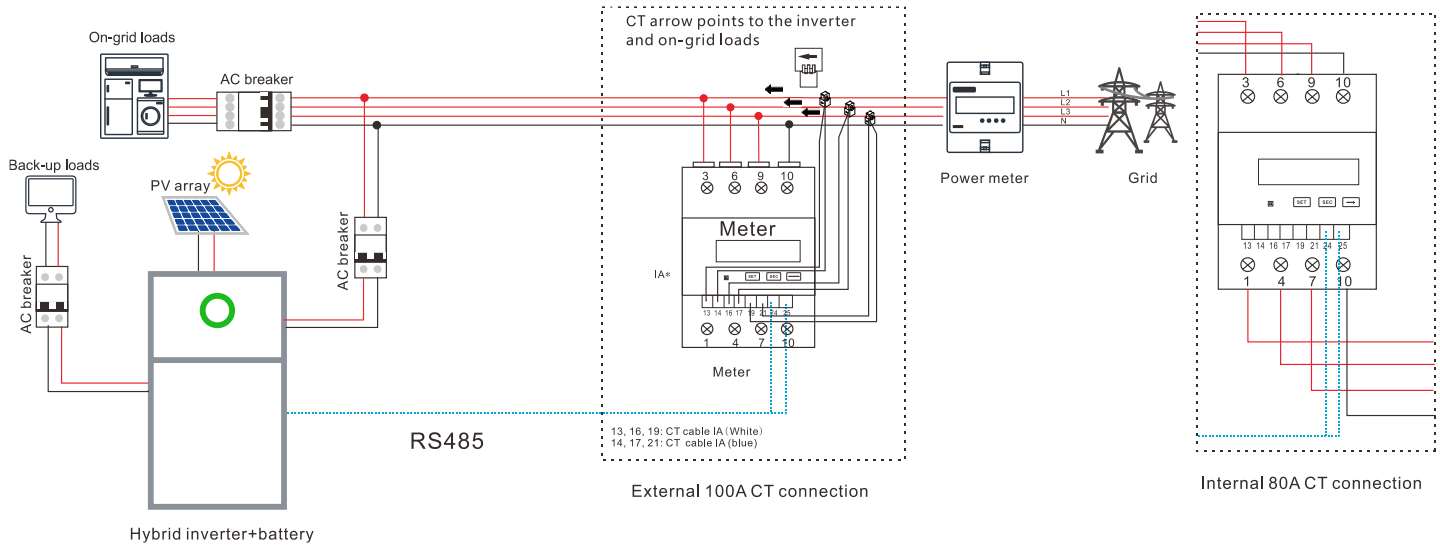

- For other scenarios, refer to Chapter 3 “System Connection: Single-phase hybrid inverter” in the *Configuration Instructions*.
 - Multiple HS3 (paralleling scenario)
 - One HS3 working with a solar inverter (AC coupling scenario)
 - Multiple HS3 working with a solar inverter (AC coupling + paralleling scenario)

6.

**STARTUP AND
SHUTDOWN**

6.1. Startup

Step 1. (Optional) If there are multiple battery stacks, turn on the battery switch on the right side of the battery junction box.

Step 2. On the left side of the inverter, perform as follows:

- a. Turn on BATTERY SWITCH.
- b. Turn on DC SWITCH.
- c. Press and hold the START button around three seconds until the LED indicator on the front panel is on .

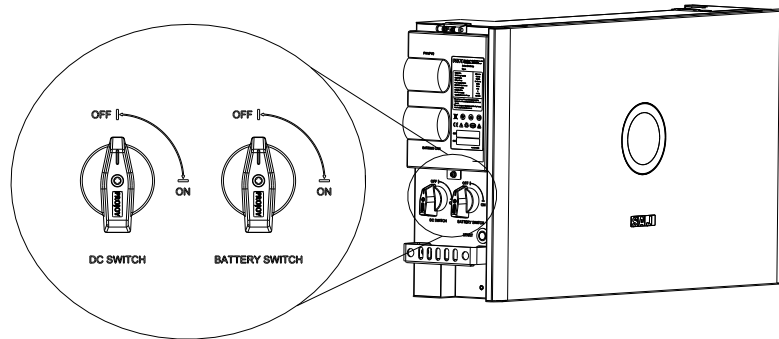

Figure 6.1. Switches on the left side of the inverter

Step 3. Check the LED indicator status on the inverter panel to ensure that the inverter is running properly.

For details, refer to section 2.5 “LED Indicators on the HS3 Inverter”.

6.2. Shutdown

On the left side of the inverter, perform as follows:

Step 1. Turn off DC SWITCH.

Step 2. Turn off BATTERY SWITCH.

Step 3. Press and hold the START button around five seconds. Then, release the button and wait until the LED indicator on the front panel is off .

7.

COMMISSIONING



7.1. About the Elekeeper App

The Elekeeper App can be used for both nearby and remote monitoring.

Depending on the communication module used, it supports Bluetooth/4G or Bluetooth/Wi-Fi to communicate with your energy storage system (ESS).

7.2. Downloading the App

On your mobile phone, search for “Elekeeper” in the App store and download the App.

Alternatively, you can scan the below QR code to download the App.

Android



iOS



7.3. Using the App

To perform commissioning operations on the App, refer to the *SAJ Configuration Guide*.

Note: The detailed operations on the App might vary, depending on the version you are using.

8.

TROUBLESHOOTING



For any errors reported as below, contact the after-sales for service support. The operations and maintenance must be performed by authorized technicians.

Error code	Error message
1	Master Relay Error
2	Master EEPROM Error
3	Master Temperature High Error
4	Master Temperature Low Error
5	Master Lost Communication M<->S
6	Master GFCI Device Error
7	Master DCI Device Error
8	Master Current Sensor Error
9	Master Phase1 Voltage High
10	Master Phase1 Voltage Low
15	Master Voltage 10Min High
16	Master OffGrid Voltage Low
17	Master Output_Shorter
18	Master Grid Frequency High
19	Master Grid Frequency Low
21	Master Phase1 DCV Error
24	Master No Grid Error
25	DC ReverseConnect Error
26	Parallel machine CAN Com Error
27	Master GFCI Error
28	Master Phase1 DCI Error
31	Master ISO Error
33	Master Bus Voltage High
34	Master Bus Voltage Low
36	Master PV Voltage High Error
37	Master Islanding Error
38	Master HW Bus Voltage High
39	Master HW PV Current High
40	Master SelfTestFailed
41	Master HW Inv Current High

Error code	Error message
44	Master Grid NE Voltage Error
45	Master Fan1 Error
49	Lost Communication between DSP and PowerMeter
50	Lost Communication between M<->S
51	Lost Communication between inverter and Grid Meter
52	HMI EEPROM Error
53	HMI RTC Error
55	BMS Lost.Conn Warn
57	AFCI Lost Com.Err
59	Lost Communication between inverter and PV Meter
60	EV_Lost.Conn Warn
61	Slave Phase1 Voltage High
62	Slave Phase1 Voltage Low
67	Slave Frequency High
68	Slave Frequency Low
69	DCDC_Lost.Conn Warn
70	DCDC_ Device Error
71	Parall CAN Lost Com. Err
72	LCD Lost comm.Err
73	Slave No Grid Error
81	Lost Communication D<->C
83	Master Arc Device Error
84	Master PVInput Error
85	Authority expires
86	DRM0 Error
87	Master Arc Error
88	Master SW PV Current High
89	Master Battery Voltage High
90	Master Battery Current High
91	Master Battery Charge Voltage High
92	Master Battery OverLoad

Error code	Error message
93	Master Battery SoftConnet TimeOut
94	Master Output OverLoad
95	Master Battery Open Circuit Error
96	Master Battery Discharge Voltage Low
97	BMS Internal Communication Error
98	Bat Sequence Error
99	Discharge Over Current Protect
100	Charge Over Current Protect
101	Module Under Voltage Protect
102	Module Over Voltage Protect
103	Single Cell Under Voltage Protect
104	Single Cell Over Voltage Protect
105	BMS Hardware Error
106	Charge Cell Under Temperature Protect
107	Charge Cell Over Temperature Protect
108	Discharge Cell Under Temperature Protect
109	Discharge Cell Over Temperature Protect
110	Relay Error
111	Pre-charge Error
112	Insulation Error
113	BMS supplier Incompatibility
114	Battery cell supplier Incompatibility
115	Battery cell Incompatibility
116	Battery pack models or grades are inconsistent
117	Circuit Breaker Is Open
118	Temperature Difference Is Too Wide
119	Voltage Difference Is Too Wide
120	Voltage Difference Is Too Wide
121	BMS Over Temperature Protect
122	Short Circuit Protect
123	Total voltage match failed

Error code	Error message
124	The system is locked
125	FUSE error protection
126	Battery Port Voltage Abnormal Protection
127	Heating film overtemperature protection
128	Abnormal temperature increases
162	Gen Start or Stop Error
225	Battery Software Overvoltage Fault
226	Battery Software Undervoltage Fault
227	Battery Discharge Software Overcurrent Fault
228	Battery Charge Software Overcurrent Fault
229	Battery Discharge Overpower Fault
230	Battery Charge Overpower Fault
233	Battery Hardware Overvoltage Fault
234	Battery Hardware Overcurrent Fault
237	Battery Voltage Exceeds BMS Upper Limit Fault
238	Battery Voltage Exceeds BMS Lower Limit Fault
239	Battery Side Precharge Fault
241	Bus Voltage Overvoltage Fault
242	Bus Voltage Undervoltage Fault
243	Bus Discharge Overcurrent Fault
244	Bus Charge Overcurrent Fault
245	Bus Discharge Overpower Fault
246	Bus Charge Overpower Fault
247	Bus Hardware Overvoltage Fault
248	Bus Hardware Overcurrent Fault
250	Auxiliary Power Source Fault
251	Hardware Protection Signal Fault
252	Bus Voltage Differential Fault
253	BMS Protection Signal Fault
254	Software Resonant Chamber Overcurrent Fault
255	Soft Start Abnormal Fault

Error code	Error message
257	Heatsink High Temperature Fault
258	Heatsink Low Temperature Fault
259	PCB High Temperature Fault
260	PCB Low Temperature Fault
261	Fan Fault
262	Heating Film Fault
274	Inverter CAN communication failure
275	Battery pack internal CAN communication fault
276	Memory fault
278	Button failure fault
289	Relay over temperature
290	Overload
291	AC over voltage
292	AC under voltage
293	AC over current
294	AC over frequency
295	AC under frequency
296	DC residual current exception A
297	Emergency Stop
298	Under temperature
299	AC residual current
300	Input terminal over temperature
301	Bluetooth fault
302	DC residual current exception B
303	Relay exception
304	Grounding error
305	Phase twisted
306	RCD circuit exception
307	RS485 Com time out
308	Electricity exception
311	Meter fault

Error code	Error message
312	cp exception, cp lower than 2V
318	Connector lock exception
319	Connector current exception
320	DC residual current exception C

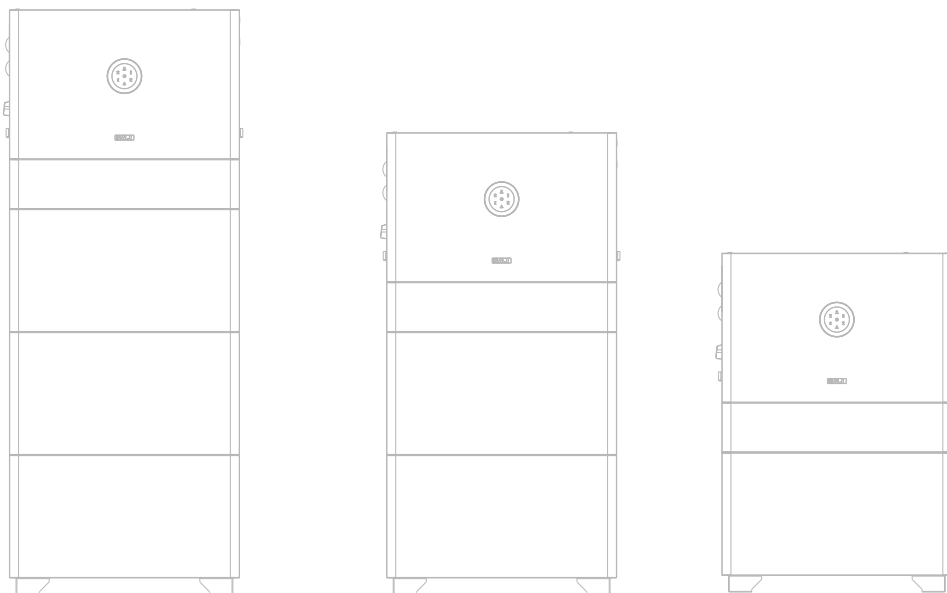

9.

APPENDIX



9.1. Recycling and Disposal

This device should not be disposed as a residential waste.

An inverter that has reached the end of its operation life is not required to be returned to your dealer; instead, it must be disposed by an approved collection and recycling facility in your area.

9.2. Warranty

Check the product warranty conditions and terms on the SAJ website: <https://www.saj-electric.com/>

9.3. Contacting Support

Guangzhou Sanjing Electric Co., Ltd.

Address: SAJ Innovation Park, No.9, Lizhishan Road, Guangzhou Science City, Guangdong, P.R.China.

Postcode: 510663

Website: <https://www.saj-electric.com/>

Technical Support & Service

Tel: +86 20 6660 8588

Fax: +86 206660 8589

E-mail: service@saj-electric.com

International Sales

Tel: 86-20-66608618/66608619/66608588/66600086

Fax: 020-66608589

E-mail: info@saj-electric.com

China Sales

Tel: 020-66600058/66608588

Fax: 020-66608589

9.4. Trademark

SAJ is the trademark of Sanjing.



GUANGZHOU SANJING ELECTRIC CO.,LTD



Tel: (86)20 66608588 **Fax:** (86)20 66608589 **Web:** www.saj-electric.com
Add: SAJ Innovation Park, No.9, Lizhishan Road, Science City, Guangzhou High-tech Zone, Guangdong, P.R.China

V0.0